

1  
2  
3  
4  
5  
6  
7  
8  
9  
10  
11  
12  
13  
14  
15  
16  
17  
18  
19  
20  
21  
22  
23  
24  
25  
26  
27  
28  
29  
30  
31

# Welcome to our interactive version of **Nitrogen+Syngas** Issue 344

Please use either the buttons on the left or top right of the page to navigate your way around this interactive PDF

#### IMPORTANT INFORMATION:

Copyright – Issued six times per year, or bi-monthly. All rights reserved. No part of this publication may be reproduced, stored in a retrieval system or transmitted in any form or by any means – electronic, mechanical, photocopying, recording or otherwise – without the prior written permission of the Copyright owner.

Number 344

November | December 2016

# nitrogen syngas

www.nitrogenandsyngas.com

Advances in platinum gauzes

Urea markets

Olefins drive methanol expansions

Integration of ammonia/urea plants



CONTENTS

What's in issue 344

COVER FEATURE 1

Advances in platinum gauzes

COVER FEATURE 2

Urea markets

COVER FEATURE 3

Olefins drive methanol expansions

COVER FEATURE 4

Integration of ammonia/urea plants

NITROGEN+SYNGAS  
**ISSUE 344**  
NOVEMBER-DECEMBER 2016

**BCInsight**

Southbank House, Black Prince Road  
London SE1 7SJ, England  
Tel: +44 (0)20 7793 2567  
Fax: +44 (0)20 7793 2577  
Web: www.bcinsight.com  
www.bcinsightsearch.com

# breakthrough catalyst technology

Johnson Matthey's new breakthrough technology, **CATACEL<sub>JM</sub> SSR**, a high performance structured catalyst for steam reforming, delivers more activity and better heat transfer at a lower pressure drop than traditional pelleted catalysts.

Our **CATACEL<sub>JM</sub> SSR** technology is proven to ease operating limits on the reformer and can allow higher throughputs because of reduced tube wall temperatures, lower pressure drop and impressive resistance to carbon deposition.

Our technical support team will work with you to assess your needs and determine if **CATACEL<sub>JM</sub> SSR** technology is a good fit for your operation.

**Catacel<sup>SSR</sup>**

[www.jmprotech.com/catacel](http://www.jmprotech.com/catacel)

  
**Johnson Matthey**  
Process Technologies

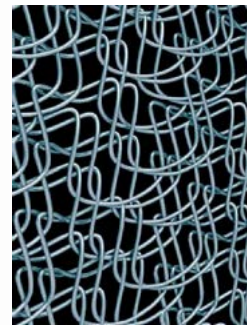

Cover: SAFINA's knitted catalyst gauze structure.  
Image: SAFINA



06

## Nitrogen industry news

New melamine plant for Henan XLX.



29

## Syngas to gasoline

Using surplus refinery hydrogen to create value.

Read this issue online at:  
[www.nitrogenandsyngas.com](http://www.nitrogenandsyngas.com)

Published by:  
**BCInsight**

# nitrogen + syngas

[www.nitrogenandsyngas.com](http://www.nitrogenandsyngas.com)  
NUMBER 344  
NOVEMBER | DECEMBER 2016

## CONTENTS

### 11 The global market for urea

Overcapacity in the urea market has driven prices to their lowest levels for several years, with more new plants on the horizon.

### 13 What's new in nitric acid and AN?

A report on new developments at this year's Ammonium Nitrate and Nitric Acid (ANNA) producers' meeting, held in Eindhoven in late September.

### 15 Olefins the key driver for methanol

The Argus Jim Jordan & Associates (JJ&A) Methanol Forum in Houston in September discussed the continued remarkable growth in demand in the methanol market, now up to 78 million t/a in 2015, with China, and especially Chinese methanol to olefin production the main market.

### 17 Putting safety first

A report from the 61st AIChE Safety in Ammonia Plants & Related Facilities Symposium which took place this year in Denver, 18-22 September 2016.

### 18 New advances in platinum gauze systems

New generation gauze systems are achieving significant reductions in precious metal losses compared to conventional gauze layouts and can operate for longer campaign runs. Hindustan Platinum, SAFINA, Johnson Matthey and Umicore describe the benefits of their latest catalyst gauze systems for nitric acid plants.

### 22 Improved economics of ammonia-urea fertilizer plants

J. Johanning and Y. Makhnya of tKIS describe a new concept for the integration of the ammonia and urea plants in a fertilizer complex and present the savings in energy consumption, waste heat to cooling water system and capital cost.

### 26 Methanol to CMTX technology

Dr Gan, senior technology advisor for Shanghai Bi Ke Clean Energy Technology Co. Ltd. (CECC) and Alan Ingham, licensing manager at Johnson Matthey discuss the latest developments in their CMTX technology.

### 27 Waste to power

A. Pandey of OPRA Turbines International discusses the utilisation of byproduct gases released during the production of ammonia in energy conversion equipment like gas turbines to generate power and heat simultaneously.

### 29 Creating new value from under-utilised hydrogen systems

Sam Golan, CEO of Primus Green Energy looks at using his company's STG (syngas to gasoline) technology as an add-on for refiners to make use of spare hydrogen to create saleable products.

## REGULARS

3 **Editorial** China and the future of methanol

4 **Price Trends**

5 **Market Outlook**

6 **Nitrogen Industry News**

8 **Syngas News**

9 **People/Calendar**

10 **Plant Manager+** Problem No. 39: Warehouse curing for urea granules

CONTENTS

What's in issue 344

COVER FEATURE 1

Advances in platinum gauzes

COVER FEATURE 2

Urea markets

COVER FEATURE 3

Olefins drive methanol expansions

COVER FEATURE 4

Integration of ammonia/urea plants

NITROGEN+SYNGAS  
**ISSUE 344**  
NOVEMBER-DECEMBER 2016

**BCInsight**

Southbank House, Black Prince Road  
London SE1 7SJ, England

Tel: +44 (0)20 7793 2567

Fax: +44 (0)20 7793 2577

Web: [www.bcinsight.com](http://www.bcinsight.com)  
[www.bcinsightsearch.com](http://www.bcinsightsearch.com)



# China and the future of methanol

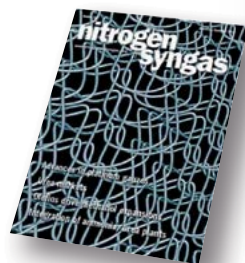

In 1999, at the World Methanol Conference in San Diego, I remember sitting through a paper given by the late Richard Hymas of what was then called Kvaerner Process Technology (the old Davy Process Technology company, subsequently sold on to Russian oil joint Yukos, before finally finding a home as part of Johnson Matthey). In it, he expounded the theory that methanol production costs were about to reach a step change downwards as economies of scale were realised (the first 5,000 t/d plants were under construction in Trinidad back then – one of them designed by Kvaerner), and that as a consequence methanol would be able to compete in new markets – as a fuel, and a chemical intermediate for process which were at the time considered too expensive, like methanol to gasoline (MTG) and methanol to olefins (MTO). The methanol industry would, he said, soon be as large as the ammonia industry, with its potential limits to growth much further out than ammonia, which is constrained by agricultural demand. An interesting idea, I thought at the time, but probably like many in the audience I was a little sceptical – the methanol industry had at the time lived through a number of false dawns, especially via fuel additive methyl t-butyl ether (MTBE), which was in the process of a doomed fight through various US legislatures at the time.

But how prophetic he turned out to be. Here we are 17 years on, and global methanol consumption is now nearly 80 million t/a – almost triple its size in 1999, and closing fast on ammonia’s 150 million t/a. I was struck recently while preparing a presentation that methanol capacity under construction is now considerably higher than ammonia capacity, and the industry has seen 11% growth rates year on year as compared to 2-3% for ammonia, even if there are signs that that growth is likely to slow over the next few years.

And yet, while production has expanded all around the world, in the Middle East, and most recently US, almost all of the demand that has driven it has come from a single source – China, and nearly all of that is down to Chinese government policy which has tried to substitute imported oil for domestic coal-based fuels and chemicals. Methanol has allowed China to extend its gasoline and LPG stocks (in the latter

case via dimethyl ether production/blending), and to replace ethylene and propylene from crackers with that derived from methanol to olefins production. While growth in fuel and DME use in China has slowed, the new wave of methanol capacity in China and elsewhere is driven now by methanol to olefins production, a surprisingly high proportion of it relying on merchant methanol from China or elsewhere. Even US shale gas may soon be feeding Chinese olefin production, via Northwest Innovation’s massive methanol projects planned for the US west coast.

It is fair to say that the technology has been proved, at the scales and prices that Richard Hymas, and indeed beyond (a 7,000 t/d plant is currently under construction). In the early years of the century, Nobel Prize winner George Olah even proposed what he called the ‘Methanol Economy’, a way of replacing oil and gas as a means of energy storage. However, signs of this actually happening are very few and far between. Resistance in China, and most likely the rest of the world, has come from two main sources – the car industry, which does not want to develop the engines required to use methanol at more than 10-15% blends, and the major oil companies, for whom methanol is not part of their traditional product offering. There are signs that methanol may be gradually gaining acceptance as a fuel blendstock in places which are worried about security of supply of oil. Unfortunately for methanol, its impetus to become a player in fuel markets in the US may have been scuppered by US shale oil production at the same time that shale gas has allowed its economic production within the US once more. ■

Richard Hands, Editor



## 5:28pm

Sept. 1<sup>st</sup> 2016 - Manasi, Xinjiang, China

The world’s largest single train high-pressure melamine plant into successful operation at XLX Fertiliser Co.Ltd.

Engineered and constructed in less than two years after contract finalization, with a nameplate capacity of 60,000 MTPY this plant sets a new record in the melamine industry, featuring the world’s largest single HP reactor.

Combined with lowest energy consumption, reduced investment and the traditional total zero pollution features, it perfectly embodies the ultimate achievements of 4<sup>th</sup> generation Euromel® Melamine technology by Eurotecnica.

**EUROMEL®  
MELAMINE  
TECHNOLOGY**



CONTENTS

What’s in issue 344

COVER FEATURE 1

Advances in platinum gauzes

COVER FEATURE 2

Urea markets

COVER FEATURE 3

Olefins drive methanol expansions

COVER FEATURE 4

Integration of ammonia/urea plants

NITROGEN+SYNGAS  
**ISSUE 344**  
NOVEMBER-DECEMBER 2016

**BCInsight**

Southbank House, Black Prince Road  
London SE1 7SJ, England  
Tel: +44 (0)20 7793 2567  
Fax: +44 (0)20 7793 2577  
Web: www.bcinsight.com  
www.bcinsightsearch.com

# Price trends



## MARKET INSIGHT

**Laura Cross**, Senior Analyst, Integer Research, assesses price trends and the market outlook for nitrogen.

### NITROGEN

Urea has been the focus of the nitrogen industry over the last few years, as it has been the most chronically affected by oversupply. Since 2015 the role of China in the urea market as the key export volume adjuster has been the standout talking point, and we at Integer have dedicated a whole study to profiling the influence and impact of the Chinese industry. The urea market remains long, and our supply-demand balance projections and analysis of future cost curve developments lead us to conclude that the oversupply correction will take at least 2-3 years to play out. However, in the short-term, urea prices have seen some stability amid temporary supply shortages in most key export regions and Indian tenders keeping Chinese sellers occupied.

Attention has recently turned to the ammonia market where prices have tumbled in recent months, with seemingly little support for prices from exporter volume adjustment. However, more recently even ammonia sellers often seen as the most competitive are feeling the impact of falling margins. In order to quantify how costs and prices impact profitability in the short term we have developed a model that tracks monthly unit margins to a number of key importers and exporters. Ukrainian producers have suffered

to the greatest extent despite having seen significant decreases in gas prices compared to 2013 and 2014. Ukrainian margins on both ammonia and urea have been negative since the beginning of 2016, and export volumes show that producers have scaled back to mostly cover domestic commitments in the current price environment.

As Ukraine's influence as a swing producer has declined and its international influence has diminished, the ammonia price has continued to fall in a long market, looking for the next swing producer. Even Russian ammonia producers, normally seen among the lowest cost nitrogen producers globally, especially given the recent impact of the weakening rouble on producers' gas costs in US dollar terms, are feeling the pinch. We estimate that based on the typical costs to market, Russian ammonia producers on average made a US\$10 per tonne loss on ammonia sales in September 2016. Indeed, some producers have already responded to the impact of falling international ammonia prices, such as Togliatti Azot which announced in October 2016 that it was considering taking six of its ammonia units offline in Q4 2016 in favour of restarting a urea line instead.

Also in Russia, vertically integrated fertilizer producer Acron is in talks with the Polish Ministry of Finance to sell its stake

in the state-owned company Grupa Azoty which it has acquired since 2012. Acron attempted to buy a controlling stake in Azoty Tarnow in 2012, before the Polish government blocked the deal and merged the country's three fertilizer producers into the state-owned Grupa Azoty. Acron then bought a 13% stake in Azoty and increased its stake to 20% in 2014. At the beginning of 2016, Acron sold a small stake, believed to be 0.3% in Azoty which led to discussions by the Polish Ministry of Finance about the long-term goal of the Polish producer. Earlier this month, the Polish treasury named state-owned gas company PGNiG, the major supplier of gas to Grupa Azoty, as the potential buyer of Acron's share which is valued at around 1.3 billion zlotys (US\$341 million).

If Poland is successful in merging its gas and downstream fertilizer activities, this would be a reversal of trend over many years which has seen gas companies divest of downstream assets in Europe and beyond. A question mark remains over the future of Acron's 20% share in Grupa Azoty, given that PGNiG also indicated that it is diverting its financial resources to rescuing Poland's coal mining industry and its interest in the fertilizer producer is unknown. The talks over the sale of shares in Grupa Azoty come at a time when the Polish fertilizer producer has been actively diversifying its gas purchases away from Russian gas towards European hub-based purchases. In 2015, Grupa Azoty purchased around 70% of its natural gas from the state-owned gas company PGNiG, which has a long-term supply contract with Russian Gazprom. PGNiG was a monopoly gas supplier in Poland until recent market liberalisation legislation in the European gas market has incentivised Grupa Azoty to increasingly diversify its gas purchases towards European spot contracts.

In terms of project activity, several new North American plants were originally due to be commissioned in Q3 2016, but delays have meant that at press time just one had been successfully completed. Incitec Pivot announced on 19th October that the performance testing and handover phase of its ammonia plant in Wagaman, Louisiana, had been completed and that the plant would operate at an average of 80% of capacity over its first twelve months. Both OCI and CF Industries' new plants in Wever, Iowa and Donaldsonville, Louisiana had most recently targeted similar Q3 completion dates but both companies have missed this milestone although they expect start up in the coming months.

## END OF MONTH SPOT PRICES

### natural gas

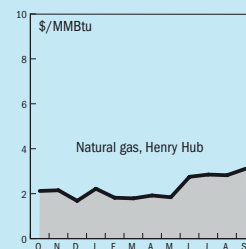

### ammonia

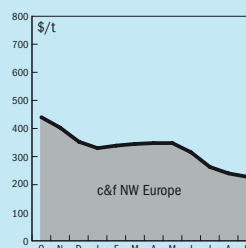

### urea

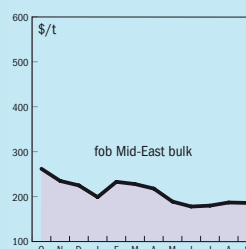

### diammonium phosphate

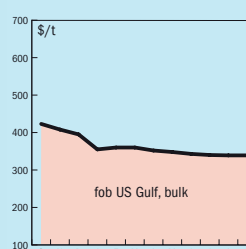

## MARKET INSIGHT

**Mike Nash**, Global Business Director, IHS Chemical, assesses the market for methanol.

### METHANOL

The US September contract gas reference price was settled at \$2.91/MMBtu for Texas, and \$2.94/MMBtu for Louisiana, up \$0.18 from August. Methanol demand is slightly down overall due to typical seasonality, with several MMA units down or planned to be so, but the industry should soon be seeing a modest uptick in winter applications. On supply the 1.9 million t/a Trinidad M5 unit was down for the whole of October, with a resulting increase in US prices, because of increased gas curtailments and inability to properly build inventory ahead of the outage. This was exacerbated by the unplanned outage at Clear Lake, and a turnaround in Venezuela. Overall North American shows an industry average operating rate of 90% but the Americas as a whole only 71%. Methanex's Chilean unit is estimated to be running around 30-35% of nameplate capacity; as the southern hemisphere moves into its spring months, gas availability should be steady as the residential heating load decreases. Further US production is expected in November next year when the 1.75 million t/a Natgasoline project starts up, increasing US exports.

In Europe, BASF's methanol unit ran normally despite a deadly explosion at a pipeline at the Ludwigshafen petrochemicals site on 17 October. Formaldehyde operating rates at the site are reduced due to logistical issues. BASF has declared force majeure with regards to the purchase of methanol into the site, due to the infrastructural bottlenecks. EU methanol supply is down as the Tomsk plant in Russia is closed for planned maintenance. According to IHS Markit integration data, BASF is net short of methanol at its facilities in Ludwigshafen (on a capacity basis, rather than actual operating basis) by 292,000 t/a. Capacity to consume methanol at Ludwigshafen is 622,000 t/a, primarily feeding into formaldehyde production. The facilities at Ludwigshafen will operate using existing inventory for the time being. With its formaldehyde unit running at minimal rates, production at BASF's own 330,000 t/a methanol unit is likely to be sufficient to cover its present demand into derivatives.

European methanol continues to price at lower levels than in the US and China. A widening price spread between methanol values in Rotterdam and the US Gulf has prompted some market participants to eye arbitrage opportunities between the two regions. The reasons are likely a lack of liquidity in the European spot market, stable supply and demand in the region, and the fact that European contracts are settled on a quarterly basis, which means they are delayed in reacting to volatility in the spot market. The 4Q West European Contract Price (freely negotiated) is currently €248/t (\$273/t). Spot typically trades at a discount of approximately 15% to contract prices in Europe, although this figure can vary.

In India, demand for methanol is healthy, although a slowdown is expected in the coming weeks during the festival of Diwali. In addition, Iranian producers are preferentially shipping methanol to China, where prices are higher. Iranian exports to China are already up 17% year-on-year, according to IHS Markit trade data. Asian market momentum remains strong. Buying sentiment and demand into key derivatives are generally healthy in major Asian markets. The regional selling price indications are very consistent across the region with offers at \$270/t or slightly above in most of Asian markets.

China's market remains strong. Bolstered by high market confidence, selling sentiment strengthened while major sellers attempted to hold their quotation levels steady. The domestic price spread across different parts of the country is relatively small at around Rmb 50. The fixed price based trade of import material is subdued due to the large gap between sellers and buyers, and the low volume of cargo arrivals in October. China domestic production is stable at around 55% of nameplate capacity (69% of effective capacity). Coal prices continue to rise, while inventory declined on both the East and South coasts. Methanol demand is stable-to-strong amongst major key derivatives. Demand into the MTO sector remains robust with major units running at high rates. MTO producer margins were squeezed in October, however, as light olefin prices remain relatively stable.

Table 1: Price indications

Cash equivalent	mid-Sep	mid-Jul	mid-May	mid-Mar
<b>Ammonia</b> (\$/t)				
f.o.b. Caribbean	195	245	280	270
f.o.b. Arab Gulf	165	305	335	320-340
c.fr N.W. Europe	230	295	358	325-355
c.fr India	225	340	383	340-388
<b>Urea</b> (\$/t)				
f.o.b. bulk Black Sea	190	176	201	200-204
f.o.b. bulk Arab Gulf*	181-193	173	190-199	230-265
f.o.b. bulk Caribbean (granular)	194	167	215	210-220
f.o.b. bagged China	196	197	209	200-205
<b>DAP</b> (\$/t)				
f.o.b. bulk US Gulf	339	340	345	360
<b>UAN</b> (€/t)				
f.o.t. ex-tank Rouen, 30% N	137	135	138	175-180

Notes: n.a. price not available at time of going to press  
n.m. no market \* high-end granular

Source: Fertilizer Week

## Market outlook

Historical price trends \$/tonne

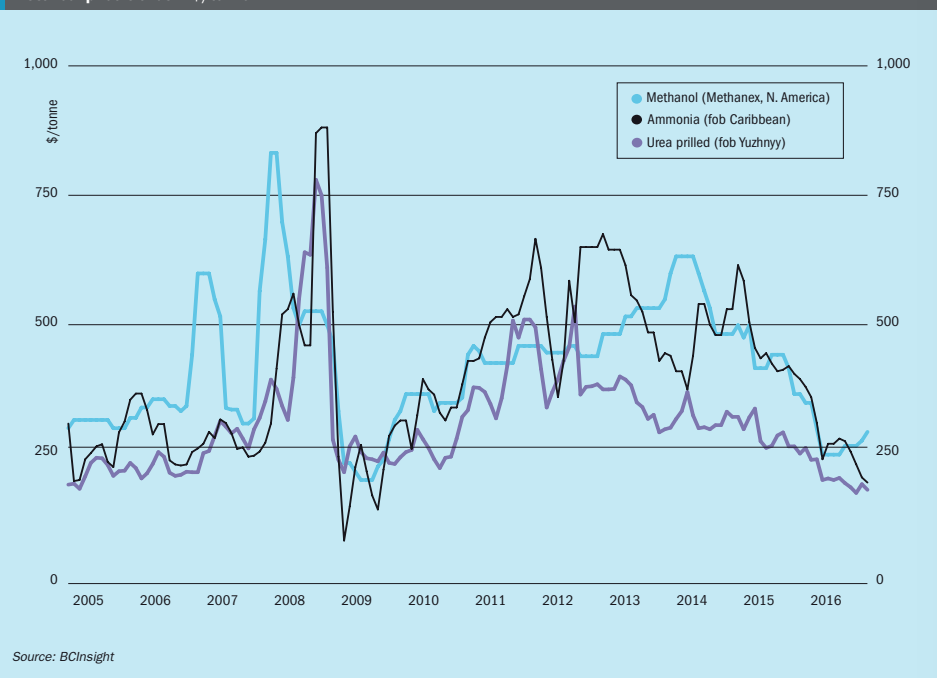

Source: BCInsight

### AMMONIA

- The ammonia market remains heavily oversupplied, which combined with slow demand in Q4 2016 is unlikely to alleviate downward pressure on prices.
- Limited activity in Asia is expected to put Far East c.fr and Arab Gulf f.o.b. prices under pressure.
- North American demand is expected to remain weak until the end of the year, with the next sizeable ammonia demand from the region only expected ahead of the spring application season in February and March.
- Incitec Pivot's new ammonia plant was commissioned in late-October and this will reduce the US import requirement.
- In Q1 2017 seasonal demand is expected to give some support to ammonia prices with sizeable spring application from the US and Europe.

### UREA

- The key driver in the urea market in Q3 2016 was the Indian import tender for

1.5 million tonnes of urea.

- Beyond this activity, short-term supply outages in key export regions were supporting global urea prices going into Q4 2016.
- In Ukraine, the government plans to lower the starting price for the privatisation of OPZ are a previous failed bid to sell the company.
- Going into 2017, demand for urea ahead of the spring application season is expected to support prices somewhat, although capacity expansions will continue to displace imports in the US.
- New US capacity is being commissioned and will make its presence felt over the coming months.
- Overall the urea market remains long, and projections and Integer's analysis of future cost curve developments suggests that the oversupply correction will take at least 2-3 years to play out.

### METHANOL

- Natural gas curtailments continue to affect availability from Trinidad, with

knock-on effects on pricing in the Americas, and more turnarounds are expected in Trinidad and Venezuela towards the end of the year.

- More US production is expected next year from the 1.75 million t/a Natgasoline unit. Longer term, Northwest Innovations continues to try and develop its major export-oriented projects for the US west coast, now agreeing to a 'zero liquids discharge' with a total recycle facility.
- China enjoyed a modest uptick in economic activity during August, although gains are likely to soften starting in the fourth quarter. Industrial value-added output accelerated by 0.3 percentage points, to a 6.3% expansion in August, owing to slower contractions among mines. IHS Energy expects Chinese economic growth to slow to 6.6% by end-2016 and 6.3% in 2017.
- In spite of lower formaldehyde production, there is no market effect seen so far from the Ludwigshafen explosion in mid-October.

## Nitric acid catalysts and process plants ...

## Total capability PGM recovery and refining services—from catalyst to storage tank—anywhere, anytime

It's what you'd expect from a worldwide—and world class—precious metals refining organization:

- Low pressure drop palladium recovery gauzes—design, installation, and refining
- Refining of PGMs from process gas and acid filters
- Recovery of PGMs from plant residues—storage tanks, vacuum cleanings, sweeps, etc.
- Non-destructive cleaning of plants and components using on-site PGM recovery services; refining of PGMs
- Destructive recovery of PGMs from redundant or decommissioned plant equipment

### Sabin maximizes platinum recovery from the catalyst

Sabin's low pressure drop palladium recovery gauzes are custom configured to reduce down time, increase production, and minimize operating costs.

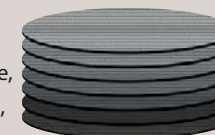

**sabin**  
METAL CORPORATION  
Nitric Acid Group  
Scottsville, NY 14546 USA  
Telephone: 585-538-2194

Tell us about your nitric acid processing and production applications at [sabinmetal.com](http://sabinmetal.com)



### CONTENTS

What's in issue 344

### COVER FEATURE 1

Advances in platinum gauzes

### COVER FEATURE 2

Urea markets

### COVER FEATURE 3

Olefins drive methanol expansions

### COVER FEATURE 4

Integration of ammonia/urea plants

NITROGEN+SYNGAS  
**ISSUE 344**  
NOVEMBER-DECEMBER 2016

**BCInsight**

Southbank House, Black Prince Road  
London SE1 7SJ, England  
Tel: +44 (0)20 7793 2567  
Fax: +44 (0)20 7793 2577  
Web: [www.bcinsight.com](http://www.bcinsight.com)  
[www.bcinsightsearch.com](http://www.bcinsightsearch.com)



## UNITED STATES

### Weatherly launches new, dual-pressure nitric-acid process

Weatherly Inc., now a wholly-owned subsidiary of KBR, has introduced a new dual-pressure nitric acid technology. The company says that it enables economically viable production of nitric acid on a large scale (>1,000 t/d), as part of large fertilizer complexes. The technology was launched at the 2016 AN-NA (Ammonium Nitrate/Nitric Acid) conference in Eindhoven, in September.

The process initially oxidises ammonia with air over a platinum catalyst at high temperature and low pressure, and passes the product of the low pressure oxidation through a heat exchanger to recover a major portion of the heat. The process gas is cooled and oxidized further in a low pressure cooler condenser, where NO, NO<sub>2</sub>, O<sub>2</sub> and water combine to form dilute nitric acid. Some of the reaction energy is recovered and used

to reheat the tail gas. The low pressure process gas is then compressed in the NOx-gas compressor, and fed to a high-pressure cooler condenser and absorber to form product nitric acid (68%). Tail gas from the absorber is reheated to 1,150°C and used to drive a hot-gas expander to generate power for the air compressor and NOx-gas compressors.

Weatherly claim that the process delivers lower operating costs via its more efficient heat-recovery design. Tail gas exits the system at 620°C, compared to the lower (490°C) temperature of alternative dual pressure processes. The process also utilises Weatherly's vertical reactor; a compact design widely used in mono-pressure nitric acid plants which requires less steel and piping than traditional plants, and lowering capital cost. ■

### Dyno Nobel completes new ammonia plant

Dyno Nobel held a ceremony to mark the official completion of their new \$850 million ammonia facility at the company's Fortier facility in Waggaman, Louisiana. Attendees included state governor John Bel Edwards, and local representatives of the Jefferson Parish Economic Development Commission (JEDCO), as well as representatives of Dyno's parent company Incitec Pivot Ltd.

"Today's ceremony marks an important milestone for our world-scale ammonia plant in Waggaman, Louisiana," Chairman of Incitec Pivot Limited Mr. Paul Brasher said. "It is the first ammonia plant to have been built in the state in over 25 years."

Gov. John Bel Edwards said; "considering our highly skilled workforce, our geographic resources and the robust economic development partnerships on the state, regional and local levels, companies from all across the globe continue to look to Louisiana as a smart and strategic destination for their next business investment."

Dyno says that the new 800,000 t/a plant will produce the lowest air emissions of any ammonia facility operating in the United States.

### TFI wins legal challenge against ammonia rule

The US Court of Appeals for the DC circuit has ruled against the Occupational Safety and Health Administration (OSHA) as regards the implementation of new stricter storage standards for anhydrous ammonia fertilizer. The three-judge panel said it was not ruling on the merits of the case, only that OSHA must go through a formal notice and comment rulemaking process if it wants to enforce stricter standards. Following the 2013 explosion at the West (Texas) Fertilizer Company, OSHA in July 2015 announced it would regulate retail sellers of farm fertilizer such as anhydrous ammonia under the same standards as manufacturers. The change was scheduled to take place on October 1st, 2016. The Agricultural Retailers Association and the Fertilizer Institute opposed the decision.

The appeals court vacated OSHA's 2015 memo, which withdrew a long-standing exemption for "retail facilities" from strict Process Safety Management hazardous materials reporting standards for anhydrous ammonia. Now, the stricter standards are suspended, pending formal rulemaking procedures.

The fertilizer industry estimates the rule could cost fertilizer suppliers around \$100,000 per facility, which would ultimately translate to higher costs for farmers.

## CANADA

### CF Industries suspends work on Courtright expansion

According to local officials, CF Industries has halted a C\$105 million urea plant expansion at its Courtright, Ontario facility, work on which was due to begin this summer. Mayor of St Clair Township Steve Arnold has blamed the Province government's proposed carbon cap and trade programme, which is due to come into effect from the start of 2017. Speaking to local media, Arnold said: "CF is not being recognized for the things they've done to mitigate their environmental footprint, things like their waste streams going into the greenhouse process on site. And yet, when people are looking at them and trying to evaluate them for cap and trade, they're not being recognized for the great efforts they've done."

Last year CF Industries announced that it would boost urea and downstream urea solutions and diesel exhaust fluid production at Courtright by 130,000 t/a.

## SAUDI ARABIA

### Ma'aden begins trial operations at ammonia plant

The Saudi Arabian Mining Company (Ma'aden) has announced the completion of construction of its new ammonia plant at the Ma'aden Waad Al Shamal Phosphate Company subsidiary in northwestern Saudi Arabia. As of early September, the plant had begun trial operations, during which production will be gradually ramped up towards the maximum capacity of 1.1 million t/a. Maaden, Mosaic and Saudi Basic Industries Corporation (SABIC) own 60%, 25% and 15%, respectively of the Waad Al Shamal Phosphate project.

## IRAN

### Joint venture formed for urea development

Rashtriya Chemicals & Fertilizers (RCF) and Gujarat State Fertilizer Corporation (GSFC) of India have formally founded a joint venture company with Iranian partner Faradast Energy Falat Company for the proposed development of a 1.1 million t/a ammonia



The new Henan XLX melamine plant, designed and built by Eurotecnica.

urea plant at Chabahar in southern Iran. The investment cost is put at \$970 million, with the aim of exporting the urea from Iran back to India, in similar manner to the Oman-India Fertilizer Company (Omifco), just across the strait of Hormuz. The plant is running parallel to a major Indo-Iranian development of Chabahar port and associated Free Trade Zone, the first phase of which is expected to be completed in 16-18 months' time. Indian investment at Chabahar, via a joint venture company of Jawaharlal Nehru Port Trust (JNPT) and Kandla Port Trust, will include equipment including steel rails, building and operating two fully constructed berths, and constructing, operating and maintaining a container terminal. According to Indian press reports, the contract for equipment has been finalised and specifications are being drawn up. Iran will take care of dredging of the port and approaches. Chabahar, in the extreme southeast of Iran, is only 1,000 km from Kandla in Gujarat state. Iran also plans a 600m rail link to connect Chabahar to central Asia.

Meanwhile, the managing director of the Lordegan Petrochemical Company in Iran, which is constructing a 1.075 million t/a ammonia-urea plant in the western interior of Iran, has said that construction is continuing and the project is now 53% complete, up from last year's estimate of 33%. Lordegan is one of eight domestic ammonia-urea complexes under development in Iran, including the Marvdasht plant which was recently completed.

## CHINA

### Start-up for largest single train high pressure melamine plant

Successful start-up has been achieved for a 60,000 t/a melamine plant at Henan XLX Fertilizers in Xinjiang, China. The plant was designed and built by Eurotecnica based on their Euromel melamine process, and is the largest single high pressure reactor to be constructed. The plant was engineered and built in less than two years from contract finalisation. Eurotecnica says that the Euromel process allows for low energy consumption, reduced investment and "zero pollution". It is one of 20 licensed Euromel plants to be designed by Milan-based Eurotecnica, part of Proman Group.

## BRAZIL

### Vale selling fertilizer business to Mosaic

Although the companies involved have been close-mouthed about the deal, it appears that Brazilian mining major Vale is in the process of selling its fertilizer business to Mosaic and Yara. Reports initially appeared in Brazil's O Globo newspaper and were partially confirmed by Reuters. It appears that 75% is being sold to Mosaic for an estimated \$3 billion, and the remaining 25% to another buyer for another \$1 billion, said to be Yara. Reuters reports that the sale has been pushed back to October 20th at the request of Brazilians state

development bank BNDES in order to give it time to properly analyse the transaction

State oil company Petrobras is also in the middle of a massive asset sale to raise capital, part of which includes the disposal of its fertilizer assets, although there are no reports of any firm bid as yet.

## INDONESIA

### Indonesia foils AN smuggling attempts

Indonesia says that it has foiled three attempts to smuggle ammonium nitrate from April to August, the three intercepted shipments totalling 166 tonnes. National Police chief General Tito Karnavian told a press conference in Jakarta that his men had "intercepted vessels from Malaysia off Sumatran waters, with the most recently caught vessel carrying 50 tonnes [of ammonium nitrate]." He said that the police had uncovered networks behind the smuggling of the substance, which allegedly is being distributed to the eastern parts of Indonesia, including to Central Sulawesi, South Sulawesi, Flores, Sumbawa and Papua. "We've been following up [the intercepted shipments] with investigation and have arrested some distributors in Central Sulawesi and Tanjung Pinang. We will further develop [the investigation] in South Sulawesi, Flores and Papua," he said.

## VIETNAM

### Coal-based producers in trouble

Local press reports indicate that Vietnam's two coal-based fertilizer plants, Ninh Binh and Ha Bac, are in serious financial difficulties resulting from overhanging loans and adverse movements in coal and urea markets. Ha Bac, owned by state producer Hanchemco (Ha Bac Nitrogenous Fertilizer and Chemical Co Ltd) spent \$570 million from 2010-2015 in upgrading and expanding the plant from 180,000 t/a to 500,000 t/a of urea output. However, it is reported to have lost \$30 million in 2015 and is on course to lose another \$22 million this year. Meanwhile Ninh Binh, owned by Vinachem (Vietnam National Chemical Co), was built from 2008-2012 at a cost of \$670 million, including \$250 million in Chinese loans, and has a nameplate capacity of 560,000 t/a. The company has been paying 4% interest on the loans, higher than a usual commercially available rate, but moreover has faced coal price rises from \$35/t to \$90/t at the same time that global urea prices have sunk from \$600/t

## CONTENTS

What's in issue 344

## COVER FEATURE 1

Advances in platinum gauzes

## COVER FEATURE 2

Urea markets

## COVER FEATURE 3

Olefins drive methanol expansions

## COVER FEATURE 4

Integration of ammonia/urea plants

NITROGEN+SYNGAS  
**ISSUE 344**  
NOVEMBER-DECEMBER 2016

# BCInsight

Southbank House, Black Prince Road  
London SE1 7SJ, England

Tel: +44 (0)20 7793 2567

Fax: +44 (0)20 7793 2577

Web: [www.bcinsight.com](http://www.bcinsight.com)  
[www.bcinsightsearch.com](http://www.bcinsightsearch.com)

to \$250/t. The plant was forced to close in May 2016 after losing money for all four years of operation, with total losses now amounting to \$120 million. The local government is now appealing to Vietnam's central government to approve a rescue package for the beleaguered plant.

Vietnam has overbuilt urea capacity, reaching a potential output of 2.65 million t/a from its four plants against domestic demand of 2 million t/a, aiming to export the rest. However, current oversupplied urea markets have been tough going. Also, while the Ph My and Ca Mau gas-based plants have generally operated well, the two coal-based plants have also been plagued by production issues.

**POLAND**

**State to buy out Acron share in Azoty**



Grupa Azoty's nitrogen facility at Pulawy.

The Polish government is said to be in talks with Russia's Acron over the sale of Acron's stake in Azoty, Poland's largest chemical group and Europe's third largest manufacturer of compound fertilizers. Acron has held a stake in the Group since 2012, after a failed attempt to buy Azoty Tarnow. The Polish government, which owns the majority share in the Group, decided at the time this was a hostile takeover and merged Azoty with other state run entities, leaving Acron with a 13% share in the merged company, which it increased to 20% in 2014. The Polish government now reportedly wishes to take 100% ownership, with state gas supplier PGNiG likely to lead the bidding. Azoty share prices at time of writing would value Acron's stake at \$340 million.

As well as sulphur, polyamides, phosphoric acid, titanium dioxide and caprolactam production Azoty has inherited all of Poland's surviving nitrogen producers – Pulawy, Police, ZAK and Tarnow, and operates 2.3 million t/a of ammonia capacity, 1.7 million t/a of urea, 1.2 million t/a of UAN solutions, as well as melamine, ammonium sulphate and calcium ammonium nitrate (CAN) production.

**GERMANY**

**Explosion kills three at Ludwigshafen**

An explosion on October 17 at BASF's sprawling Ludwigshafen chemical complex killed three and injured 25. The three dead are believed to have been site firefighters. BASF said the blast occurred as work was taking place on a pipeline in the North Harbour area, where lines run from storage tanks where crude oil distillates are offloaded from tankers to the site's steam crackers, but a cause of the accident is not yet known. The site operates two naphtha-based steam crackers which provide the ethylene and propylene feed for several downstream plants in the site. The explosion and fire led to a shutdown of the crackers and a knock-on effect on 24 other units at the site, although it is not believed that the 500,000 t/a ammonia plant at the complex was affected.

**FRANCE**

**IFA inaugurates Global Fertilizer Day**

On October 13th, the International Fertilizer Industry Association (IFA) inaugurated the first Global Fertilizer Day, three days ahead of World Food Day on October 16th. The day aimed to celebrate fertilizers as one of the most important inventions of our time, contributing to an estimated 50% of today's food production. As part of the celebration, IFA highlighted seven ways that the fertilizer industry is contributing to global food security and promoting sustainable fertilizer use, including: connecting African smallholders to input markets; helping expert volunteers to build fertilizer value chains in Africa; the 4R Nutrient Stewardship programme; new smartphone apps and web-based tools which can help farmers with nutrient management advice; training agro-input dealers in East Africa to advise farmers on fertilizer use; strengthening science and technology transfer in China; and the "Protect & Sustain" Product Stewardship initiative.

"Fertilizers play a key role in this process, ensuring our soils have the vital nutrients they need to grow healthy crops," says Charlotte Hebebrand, Director-General of IFA. "In recognition of this responsibility, the fertilizer industry supports a range of initiatives which aim to make fertilizer use as efficient, productive and sustainable as possible."

**NIGERIA**

**Abraaj Group buys into Indorama**

The Abraaj Group says that it has acquired a minority stake in Indorama Fertilizers, the largest urea producer in Sub-Saharan Africa. Abraaj is a Dubai-based private investment group which has investments in high growth regions across Asia, Latin America and Africa. In a statement the company said that it will "use its expertise and networks to support Indorama Fertilizer's market penetration and future expansion plans, as well as help ensure best-in-class corporate governance." Indorama is an Asian holding company which owns the Indorama Eleme fertilizer plant at Port Harcourt, Nigeria. The facility, completed earlier this year, comprises a 2,300 t/d ammonia plant, and a 4,000 t/d granulated urea plant.

Commenting on the investment, Arif Naqvi, founder and Group Chief Executive of the Abraaj Group, said: "This is a landmark transaction for Abraaj in Sub-Saharan Africa. We are privileged to be partnering with Indorama Corporation to create a global fertilizer leader in Africa. Since establishment, Indorama Fertilizers has led the local market in an industry characterized by high levels of demand and insufficient supply of quality fertilizer in the region. Having successfully invested in the fertilizer business in North Africa, we look forward to leveraging that know-how and working with the management team in developing the company's route-to-market infrastructure, build its network and support its capacity expansion and product diversification plans in the region."

Sri Prakash Lohia, founder and Group Chairman, Indorama Corporation, said: "We are pleased to welcome The Abraaj Group as an investor in our fertilizer business as we endeavor to create a world-class manufacturing and distribution network for fertilizers in the African continent, to meet the needs of underserved farmers and help propel the growth of the agricultural sector even further."



**We know our way around engineering**

Think about thousands of highly skilled professionals operating in the **oil & gas processing, petrochemicals and fertilizer industries**: this is Maire Tecnimont Group, a plant engineering leader dedicated to providing consumers at the end of the value chain with **energy in its different forms**. We create value with innovative products for a countless number of industrial applications embedded in everyday life.



Maire Tecnimont Group

**30 COUNTRIES**  
**45 OPERATING COMPANIES**



**CONTENTS**

What's in issue 344

**COVER FEATURE 1**

Advances in platinum gauzes

**COVER FEATURE 2**

Urea markets

**COVER FEATURE 3**

Olefins drive methanol expansions

**COVER FEATURE 4**

Integration of ammonia/urea plants

NITROGEN+SYNGAS  
**ISSUE 344**  
NOVEMBER-DECEMBER 2016

**BCInsight**

Southbank House, Black Prince Road  
London SE1 7SJ, England  
Tel: +44 (0)20 7793 2567  
Fax: +44 (0)20 7793 2577  
Web: www.bcinsight.com  
www.bcinsightsearch.com



RUSSIA

## Ammonia-methanol complex planned for east coast

A consortium led by South Korean company Hyundai Engineering has won a \$5.1 billion contract to build a major fertiliser manufacturing complex in Russia's Pacific port city of Nakhodka. The consortium also includes Toyo Engineering and Hyundai Engineering and Construction. The contract was awarded by Russia's National Chemical Group, which purchased the Minudobreniya ammonia/urea unit last year, and which is believed

to be owned by Russian construction magnate Arkady Rotenburg. Interfax also reports that Ukrainian DF Group owner Dmitri Firtash will partner Rotenburg on the Far East project. The agreement was signed by Korean president Park Geun-hye and Russian president Vladimir Putin on September 3rd at an international economic forum in Vladivostok.

The lump sum, turnkey contract covers five plants – two 3,300 t/d ammonia

plants, two 3,000 t/d urea plants and a 3,000 t/d methanol plant. Feedstock will be provided from Russia's Sakhalin and Yakutia fields according to National Chemical Group.

The company is looking towards exports to south and southeast Asia and Latin America, and intends to build a dedicated port terminal at Nakhodka to facilitate this. Construction is due for completion by mid-2021.

NETHERLANDS

### Waste to methanol plant proposal

A consortium is looking to build a waste gasification-based methanol plant at the port of Rotterdam, using technology developed by Enerkem to produce syngas from residual municipal waste (i.e. waste that cannot be otherwise recycled). The consortium consists of: AkzoNobel, Van Gansewinkel, Air Liquide, AVR, Enerkem and the Port of Rotterdam, and they have collectively agreed to work on optimising and completing the initial feasibility study, which will include deciding the exact location within the port of Rotterdam, and starting the application process for the necessary permits.

A final investment decision is expected in the first half of 2017. Enerkem has operated a 30,000 t/a municipal waste to methanol facility in Edmonton, Canada

since late 2014. The size of the proposed Rotterdam facility has not yet been disclosed, but Rotterdam and Edmonton are cities of a comparable size and, presumably, waste output.

UNITED KINGDOM

### First shale gas arrives in UK

INEOS confirmed that the *INEOS Insight* safely docked at the Grangemouth terminal in Scotland in late September, carrying 27,500m<sup>3</sup> of ethane from the Marcellus shale field in the US, via a 300 mile pipeline from western Pennsylvania to the Marcus Hook export facility near Philadelphia. This is the first time that US shale gas has ever been exported from the USA to the UK.

Jim Ratcliffe, chairman and founder of INEOS, said, "This is a game changer for

British manufacturing. It... guarantees the security of thousands of jobs in Scotland and could spark a shale gas revolution".

UNITED STATES

### Construction contract awarded for Natgasoline plant

US construction company Bilfinger has won the \$100 million contract for construction of the Natgasoline methanol plant in Beaumont in southeastern Texas. Orascom Engineering & Construction is the EPC contractor for turnkey construction of the plant, and has contracted Bilfinger to provide services for them. Bilfinger will provide complete mechanical assembly, including piping construction, steel construction as well as insulation, painting, scaffolding, corrosion protection, fire protection and turnover of complete mechanical systems. Nearly 1,900 tonnes of steel will be processed and over 65,000 meters of piping laid, requiring more than 34,000 welding seams. Total manpower at the project will peak at approximately 700, including 70 specialist welders, to complete the work by the end of April 2017. The Natgasoline methanol plant will have a capacity of 1.75 million t/a when complete, making it the largest in the US when it comes on stream in 2H 2017.

### Construction complete at ENVIA GTL plant

Velocys says that construction of ENVIA Energy's GTL plant in Oklahoma City is now complete. On-site loading of catalyst into the Fischer-Tropsch reactors has been completed by Velocys with support from Mouri, and pre-commissioning work, including hydro-testing of the lines and vessels, and a rigorous inspection process, is

substantially complete. Velocys says that it has been supporting EPC contractor Ventech, in leading and executing the planning for the commissioning, start-up and operation of the plant, and a Velocys operations team, which is serving under the ENVIA plant manager, will support ENVIA through commissioning, start-up and early stage operations until the permanent operations team is phased in over a planned period.

David Pummell, CEO of Velocys, said: "Operational start-up of the ENVIA plant is now within sight; its successful steady state operation will represent the next seminal milestone for Velocys and a significant step for the smaller scale GTL industry. Velocys and its partners continue to work together on site in a high-performing professional collaboration and I remain confident that we will continue to build on this progress to deliver a safe and successful start-up of the plant in the near future, and the timely production of in-specification product."

### Progress on Kalama methanol plant

Incremental progress continues to be made on the Chinese-backed Northwest Innovation mega-methanol project at Kalama, Washington State. A final Environmental Impact Statement (EIS) has been completed following the end of the public comment period, and will form the basis of the local government's decision whether or not to proceed, expected in a few weeks. A State panel that reviews large energy projects – the Energy Facility Site Evaluation Council – has also declined jurisdiction over the plant following a request by environmental group Columbia Riverkeeper to have the project reviewed by the council. Northwest Innovation appears to have faced far less opposition at Kalama than its proposed Tacoma site, where development was halted in March after strong local opposition.

In August 2015, Northwest Innovation signed an agreement with Johnson Matthey to adopt a pioneering ultra-low emissions (ULE) reforming technology for the plant. According to JM, under the previously considered technology, permitting analysis found that the Port of Kalama facility could have emitted between 1.0-1.3 million t/a of CO<sub>2</sub> for the 5,000 t/d production methanol per line (two trains are initially planned). JM's analysis suggests emissions could be reduced by up to 75% for the same level of methanol production. Methanol produced at the facilities is planned to be exported to China to feed methanol to olefins units there.



The ENVIA GTL plant at Oklahoma City.

PHOTO: VELOCYS

AZERBAIJAN

### SOCAR to acquire AzMeCo

Azerbaijan's state oil company SOCAR (State Oil Company Azerbaijan Republic) may acquire the country's AzMeCo methanol production company until late 2016, according to the company's vice president for economic issues Suleyman Gasimov. The takeover will be part of a rearrangement of Azerbaijan government debt. AzMeCo's debts are owed to the International Bank of Azerbaijan, which is being restructured to rid it of 'distressed assets' acquired via poor management. These debts are being managed separately by the Aqrarkredit CJSC non-banking credit organisation, to whom the AzMeCo debt would be transferred. SOCAR would then acquire AzMeCo via auction to cover debt owed by the Azerenergy national energy operator to SOCAR. As SOCAR provides the gas supply to AzMeCo, the theory is that the company would be then placed on a sounder financial footing.

PERU

### New hydrogen plant

Praxair, Inc. says that it has successfully started up a hydrogen plant at Refineria la Pampilla in Callao, near Lima, Peru's capital. The plant was built for Repsol, one of the world's largest producers of hydrocarbon fuels and petrochemicals. The 12 million scf/d hydrogen plant, based on steam

methane reforming, will also include a new Praxair facility adjacent to the plant which will recover and purify carbon dioxide generated by the reformer for the production of food-grade liquid CO<sub>2</sub>. The product will be used to meet customer demand in the Peruvian market, according to Praxair.

The hydrogen plant will help La Pampilla produce low-sulphur diesel fuel that complies with strict environmental standards.

JAPAN

### Hydrogen from renewables

Still recovering from the nuclear meltdown following the tsunami of 2011, Fukushima Prefecture in Japan is now looking at a project to build a large hydrogen production site using surplus electricity from renewable power generation. Three power companies have announced a joint feasibility study into the project; Toshiba Corp., Tohoku Electric Power Co. and Iwatani Corp. The companies are looking at 10MW of renewable power generation, using solar, wind and other renewable energy sources, with surplus electricity being used to electrolyse water to generate hydrogen for use in fuel cell vehicles during the 2020 Tokyo Olympic Games. Production of 900 t/a of hydrogen is proposed, sufficient to power 10,000 fuel cell vehicles, according to the companies. The feasibility study will be completed by 2017. Japan is aiming to increase renewables use to 22-24% by 2030.



INEOS Insight docks at Grangemouth.

CONTENTS

What's in issue 344

COVER FEATURE 1

Advances in platinum gauzes

COVER FEATURE 2

Urea markets

COVER FEATURE 3

Olefins drive methanol expansions

COVER FEATURE 4

Integration of ammonia/urea plants

NITROGEN+SYNGAS  
**ISSUE 344**  
NOVEMBER-DECEMBER 2016

**BCInsight**

Southbank House, Black Prince Road  
London SE1 7SJ, England  
Tel: +44 (0)20 7793 2567  
Fax: +44 (0)20 7793 2577  
Web: www.bcinsight.com  
www.bcinsightsearch.com



# People

Agrium and PotashCorp have agreed that Agrium CEO **Chuck Magro** will be the head of the new merged company. Magro, at 46, will be one of the youngest chief executives of a major Canadian company. His PotashCorp counterpart, **Jochen Tilk**, will be the executive chairman of the merged company, which has still yet to agree on a name. Magro was named president and chief executive officer of Agrium in January 2014, after joining Agrium in 2009. He has served as Agrium's COO and was accountable for two Strategic Business Units (Wholesale and Retail) and Human Resources. He has also held the roles of Executive Vice President, Corporate Development & Chief Risk Officer and was responsible for a number of core areas, including Corporate Development & Strategy, EHS&S, Sustainability & Stakeholder Relations, Internal Audit, and Risk Management. Before that, he was Vice President, Manufacturing, responsible for Agrium's Wholesale manufacturing facilities.



Chuck Magro.

Haldor Topsoe held a ceremony in early September to celebrate the official opening of the company's new office in Tehran, intended to reinforce ties with Iranian petrochemical and refining companies.

Managing director **Jens Ole Madsen** will head Topsoe's Tehran office, and spent several months in the country during its setting. Speaking at the opening ceremony, he said: "Iran's unique combination of abundant natural resources and highly skilled people holds enormous potential. In our recent deals

within methanol and ammonia, it has been confirmed that Topsoe's leading products and services can be very relevant in realizing this potential, in some cases combined with our joint venture Ferrostaal Topsoe Projects."

Per K. Bakkerud, executive vice president of Topsoe's Chemical Business Unit and the EMEA region added: "We are excited to open the new office and resume the great working relationship with Iran and the companies here. It means that we are close to our Iranian customers and partners so we can be the responsive and agile business partner they need."

The event attracted a large number of top executives from the Iranian refining and petrochemical business, who listened to

speeches by Hossein Alimorad, Investment Director of the National Petrochemical Company and other prominent speakers.

Israel Chemicals Ltd, one of the country's biggest industrial companies, has appointed **Asher Grinbaum** as its acting chief executive. Grinbaum's appointment follows the resignation of Stefan Borgas who had been CEO since September 2012, citing "personal reasons". Grinbaum is ICL's former COO, and has been with the company for more than 40 years. ICL says that it has appointed a search committee to find a permanent replacement for Borgas. ICL and Borgas have both denied that the move has anything to do with a sexual harassment claim made by a former employee.

Methanex has announced the appointment of **Doug Arnell** to its board of directors from October 1st, 2016. Mr. Arnell's background is from senior management experience in the global energy sector. From 2010 until 2015 he was Chief Executive Officer of Golar LNG and he will continue to act as a Senior Advisor and director to that company. Golar LNG, based in the United Kingdom, is one of the world's largest independent owners and operators of LNG carriers. In 2015 Mr. Arnell founded Helm Energy Advisors which provides consulting and advisory services to the global energy sector. Mr. Arnell, a Canadian resident, also serves as a director of Veresen Inc. Prior to joining Golar LNG, Mr. Arnell held a variety of senior positions, including at BG Group and El Paso Europe.

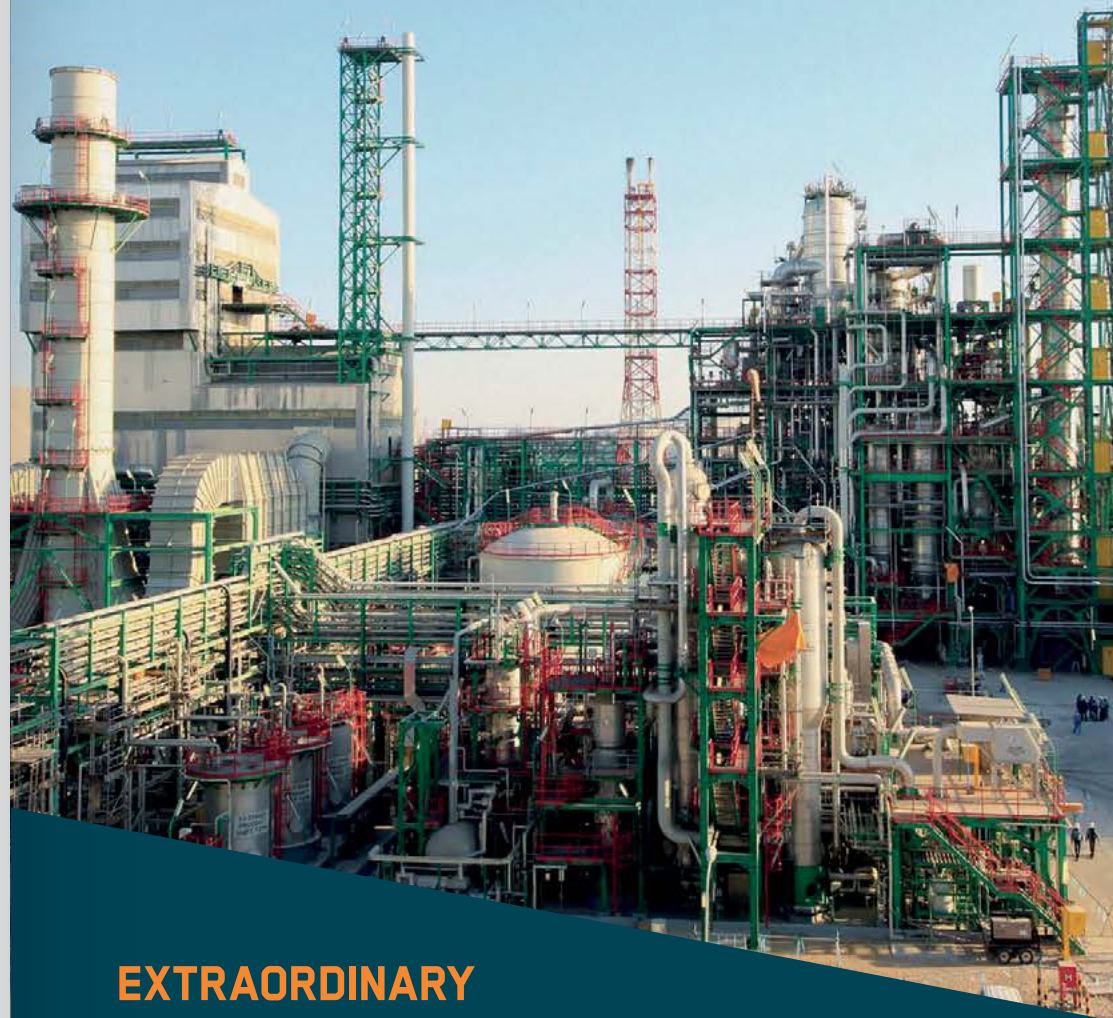

## Calendar 2016/17

### NOVEMBER

7-11

IFDC Granular Fertilizer Production Workshop, BANGKOK, Thailand  
Contact: IFDC  
P.O. Box 2040, Muscle Shoals, Alabama 35662, USA  
Tel: +1 256 381 6600  
Email: training@ifdc.org

21-23

CRU Asia Nitrogen 2016 Conference, JAKARTA, Indonesia  
Contact: CRU Events, Chancery House, 53-64 Chancery Lane, London, WC2A 1QS, UK  
Tel: +44 (0) 20 7903 2444  
Fax: +44 (0) 20 7903 2172  
Email: conferences@crugroup.com

### FEBRUARY 2017

27-30

IFA Global Safety Summit, AMMAN, Jordan  
Contact: IFA Conference Service  
Tel: +33 1 53 93 05 00  
Email: ifa@fertilizer.org

27 Feb-2 March

Nitrogen+Syngas 2017, LONDON, UK  
Contact: CRU Events  
Tel: +44 (0) 20 7903 2444  
Fax: +44 (0) 20 7903 2172  
Email: conferences@crugroup.com

### APRIL

24-27

SynGas Association Meeting 2017, TULSA, Oklahoma, USA

Contact: SynGas Association  
Tel: +1 225 922 5000  
Web: www.syngasassociation.com

### MAY

22-24

85th IFA Annual Conference, MARRAKECH, Morocco  
Contact: IFA Conference Service  
28 rue Marbeuf, 75008 Paris, France  
Tel: +33 1 53 93 05 00  
Email: ifa@fertilizer.org

### JUNE

29-30

International Fertilizer Society Technical Conference, LONDON, UK  
Contact: International Fertiliser Society  
P.O. Box 12220, Colchester, CO1 9PR, UK  
Tel: +44 1206 851819  
Email: secretary@fertiliser-society.org

## EXTRAORDINARY IS OUR EVERYDAY

With proven capabilities and a hands-on, co-operative and consistently innovative approach, Saipem builds long-term relationships, maintains intellectual and operational flexibility, and succeeds where others can't.

Saipem makes great things happen.

Thanks to over 130 licenses in 34 countries, Saipem leads in innovation with Snamprogetti™ Urea Technology.

WWW.SAIPEM.COM



### CONTENTS

What's in issue 344

### COVER FEATURE 1

Advances in platinum gauzes

### COVER FEATURE 2

Urea markets

### COVER FEATURE 3

Olefins drive methanol expansions

### COVER FEATURE 4

Integration of ammonia/urea plants

NITROGEN+SYNGAS  
**ISSUE 344**  
NOVEMBER-DECEMBER 2016

**BCInsight**

Southbank House, Black Prince Road  
London SE1 7SJ, England  
Tel: +44 (0)20 7793 2567  
Fax: +44 (0)20 7793 2577  
Web: www.bcinsight.com  
www.bcinsightsearch.com

# Plant Manager+

## Problem No. 39 Warehouse curing for urea granules

Good storage and housekeeping practices are always important to ensure a safe workplace. Where possible, fertilizers should be stored in closed storage to protect the product from the weather (sun, rain etc.). The ideal storage conditions are:

- Enclosed building capable of protecting the product from the weather and sunlight
- Temperature between 5 and 50°C
- Protect the fertilizer from moisture, which can cause lumps and dust, affecting spreading capabilities
- Good stock management e.g. carried out on a first in first out basis.



**Muhammad Kashif Naseem from SABIC, Saudi Arabia starts this round table discussion:** Can anyone explain the warehouse curing phenomenon for granulated urea product and the maximum time required for this, particularly in the summer season in the Gulf region with a product outlet temperature of around 50°C?

**Mark Brouwer from UreaKnowHow.com replies:** Intentional aging or curing of fertilizer in a storage pile prior to bagging or bulk shipment is referred to as curing. Chemical reactions that cause caking bonds proceed to near completion during the curing period. The heat of reaction retained in the curing pile speeds up the completion of the reactions. After curing there is reduced tendency for additional bonds to develop. What is your experience of the time required for curing?

**Akbar Ali from SAFCO-SABIC, Saudi Arabia raises a good question:** In urea granulation the curing time is 60 to 72 hours. Can we understand from your comments that the length of curing time is due to chemical reactions causing caking bonds or is there any other reason behind this? Have you any literature on curing time for urea granules showing how we can decide on the curing time for a specific product temperature?

**Muhammad Kashif Naseem from SABIC, Saudi Arabia replies:** Almost three days is considered normal, but can we reduce this or is there any method available to reduce this warehouse curing time?

**Easa Norozipour from KHPC, Iran answers the last question:** As we know, curing is a phenomenon for stabilisation of a humid and high temperature product like urea. In this case, I think the curing time also depends on the following:

- water content in the final product;
- amount of ammonia content in the product;
- temperature of the final product;
- the delta temperature between warehouse and environment;
- height of the urea pile in the warehouse;
- relative humidity of the environment;
- size of the final product.

All of these items can influence the curing time of the final product. In our experience three days is the normal time.

**Zaheer Abbas from SAFCO, Saudi Arabia shares his experiences:** In my experience, our final check is the temperature differential between the urea granules and warehouse ambient conditions.

Whatever the humidity outside, it will finally affect the temperature differential. If we are able to maintain the recommended temperature differential ( $\Delta T = +5^\circ\text{C}$ ), the curing time will be automatically adjusted. I would recommend taking some temperature measurements before deciding on the curing time for any warehouse. Other contributing factors are final cooler efficiency and the difference between wet bulb and dry bulb temperature inside of warehouse.

**Mark Brouwer from UreaKnowHow.com provides more information:** Another important consideration is that caking behaviour is in part determined by the amount of dust and fines in the product.

**Easa Norozipour from KHPC, Iran shares more information:** Sometimes near the Gulf the humidity is very high and we have experienced a lot of water droplets in and around the urea belt conveyor. As we know, there aren't any warehouse and belt conveyor channels with 100% sealing. Therefore the relative humidity of the environment can increase the caking tendency. The mesh size (dust) of the final product is also an important factor as mentioned already by Mark.

**Akbar Ali from SAFCO-SABIC, Saudi Arabia asks a question:** Do you have any written information regarding this subject? I could not find anything in the Stamicarbon documents.

**Janusz Maćkowski from ZCh"Police", Poland provides a reference:** At the Tenth Stamicarbon Urea Symposium 2004 (Round Table Presentation) there was an interesting article "Improvements in the physical quality of urea prills". I think it is also related to this topic.

**Nick Sutherland from SOLEX Thermal Science Inc., UK provides some useful information:** As we know, urea (and all other fertilizers) are hygroscopic and as such if sent to the storage area while still at a temperature above that of the local ambient conditions any moisture in the air will be attracted to the product, this is obviously a problem in climates where the humidity is high and if the product has even a small amount of dust then "caking" is likely to occur.

To reduce this situation I recommend you consider the Solex Bulk Flow Cooler which can cool the product closer to the ambient temperature with the added benefit of not generating any further dust, in fact the unit, in conjunction with a de-dusting system, can reduce the dust load.

**Muhammad Kashif Naseem from SABIC, Saudi Arabia contributes to the discussion:** Product dust formation is influenced by:

- moisture or humidity;
  - differential temperature of atmosphere and product;
  - free ammonia in product;
  - strength of product;
  - pressure in final product system (prilling tower + granulator scrubber);
  - frictional resistance of the conveying system.
- Methods to prevent dust formation include:
- UF-85;
  - Urecoat/Ureasoft;
  - seeding technology;
  - suitable temperature and pressure in final concentrator.

**Mark Brouwer from UreaKnowHow.com provides more information:** Freshly produced urea granules need some kind of "curing time" to reach their final anticaking quality. Normally 1 or 2 days will do the job.

The product leaving the granulator has been screened to remove the undersize and oversize particles in order to produce an end product of typically 95% between 2 and 4 mm. That means that your end product is a mixture of granules from 2 mm up to 4 mm diameter. That seems to be very close but in terms of weight per granule the difference is huge. The weight of a 4 mm granule is about 8 times higher than the weight of a 2 mm granule.

Because of this big weight difference, a 4 mm granule will be more difficult to fully dry out than a 2 mm granule. The result is that a 2 mm granule has a lower moisture content than a 4 mm granule. The moisture figure you get from the laboratory during production is the average moisture of the granule mixture. You can easily check this by determining the moisture content of the fines recycle product and of the oversize before crushing. You will find a very big difference.

This series of discussions is compiled from a selection of round table topics discussed on the UreaKnowHow.com website. UreaKnowHow.com promotes the exchange of technical information to improve the performance and safety of urea plants. A wide range of round table discussions take place in the field of process design, operations, mechanical issues, maintenance, inspection, safety, environmental concerns, and product quality for urea, ammonia, nitric acid and other fertilizers.

## FREE WEBINARS AND PRESENTATION SLIDES:

Nitrogen | Phosphate | Potash | Sulphur

Integer Research are delighted to offer you free access to our market outlook webinars and presentation slides for nitrogen, phosphate, potash and sulphur markets.

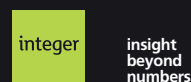

FREE ACCESS HERE: [www.integer-research.com/free2015](http://www.integer-research.com/free2015)

When you dump your freshly produced end product on a pile in storage, this moisture difference will slowly disappear: finer product will pick up moisture from the bigger product. This moisture "migration" will cause some caking in the fresh pile. Once the moisture migration is finished and you break the slight caking (during shipping) this initial caking will not happen again.

Of course that does not mean that your product will be 100% cake-free: the normal rules remain, low moisture is better than high moisture, low temperature is better than high temperature, a low pile is better than a high pile, etc.

**Adel Tabel from Pardis Petrochemical Company, Iran raises new questions:** Is it possible for the caking phenomena to occur during shipping (at high humidity condition) after sufficient curing time of urea in the warehouse? Or if we have a sufficient curing time in the warehouse, will that prevent caking during shipping? Or are these not related?

**Gholamali Soroush from Shiraz Petrochemical Complex, Iran replies to the raised question:** Besides the drying time, the urea curing process depends on humidity, temperature, piling height, and so on. Even if there are no changes in the temperature and humidity (good sealing) from the warehouse to the destination, there may be some reduction in urea quality that reduces the urea crushing strength. Urea powdering (degradation) is related to the granule formation step and the quality of the anti-caking agent. In some destinations, the environmental dew point (humidity and temperature) may have less impact on the urea than the warehouse. However, if urea encounters a reduction in temperature and an increase of humidity from loading port to destination, some moisture can become trapped in the urea granule. Humid air can also diffuse into the urea granule leading to caking. For these reasons, besides the control of all the usual parameters, I suggest using good quality urea formaldehyde, and spraying anti-caking agents after the granulation step to ensure customer satisfaction. ■

## CONTENTS

What's in issue 344

## COVER FEATURE 1

Advances in platinum gauzes

## COVER FEATURE 2

Urea markets

## COVER FEATURE 3

Olefins drive methanol expansions

## COVER FEATURE 4

Integration of ammonia/urea plants

NITROGEN+SYNGAS  
ISSUE 344  
NOVEMBER-DECEMBER 2016

BCInsight

Southbank House, Black Prince Road  
London SE1 7SJ, England  
Tel: +44 (0)20 7793 2567  
Fax: +44 (0)20 7793 2577  
Web: [www.bcinsight.com](http://www.bcinsight.com)  
[www.bcinsightsearch.com](http://www.bcinsightsearch.com)



# The global market for urea

Overcapacity in the urea market has driven prices to their lowest levels for several years. With more new plants on the horizon, there seems little prospect of a sea change in the immediate future.



The Iowa Fertilizer Company plant at Wever, due to begin production soon.

PHOTO: ORASCOOM

Urea continues to be the most popular and widely traded of all nitrogen fertilizers, seeing a steady rise in its use, especially in Asia. Because of its high nitrogen content (46%), it is seen as one of the most cost-efficient ways of delivering nitrogen to soils. While industrial and chemical uses are a faster growing segment of the market, demand remains dominated by agricultural uses; it is relatively easy to apply to fields, and has been favoured in developing countries with less sophisticated agricultural distribution chains and application methods. It is also not subject to the same shipping, handling and storage regulations which have restricted ammonium nitrate's use as a fertilizer. However, as a consequence the politics of energy and agriculture often distort the market for urea itself.

## Urea demand

As noted above, urea consumption is very much driven by agriculture; about 80% of urea goes to agricultural use, with only 20% going to industrial or so-called 'technical' uses. Agricultural demand has gradually slowed as end use markets mature, and these days there is more emphasis on more efficient application of fertilizer, but the UN Food and Agriculture Organisation (FAO) still predicts that overall demand for nitrogen fertilizer will continue to rise at around 1.25% year-on-year for the rest of the decade. The region with the highest rate of growth over that period is forecast to be sub-Saharan Africa, where the rate of increase is put

at 4.4%, but demand there is beginning from a much lower base. Demand is still increasing by 2-3% per year in regions like India, South America and Central Asia, but the slowdown in demand in China and declining demand in Europe bring down the overall global total.

The main non-agricultural use is in urea-formaldehyde resin manufacture, and there are a variety of other chemical uses,

including melamine, which has increasingly been seen as a useful side-stream for some urea plants, with production synergies. The use of urea solutions for selective catalytic reduction (SCR) systems for commercial vehicle exhausts in order to comply with tighter emission regulations has also led to increasing technical demand for urea in Europe and the US.

Table 1: Urea figures for major producers and consumers, 2014, million tonnes N/year

Country	Production	Consumption	Exports	Imports
China	30.50	24.25	6.25	0.00
Russia	3.18	0.68	2.43	0.00
Qatar	2.50	0.20	2.30	0.00
Saudi Arabia	1.67	0.14	1.53	0.00
Oman	1.26	0.00	1.28	0.00
Iran	1.66	0.85	0.81	0.00
Ukraine	1.02	0.34	0.76	0.00
Egypt	1.47	0.96	0.52	0.00
Indonesia	3.13	2.66	0.51	0.00
Venezuela	0.49	0.20	0.29	0.00
Malaysia	0.57	0.30	0.44	0.17
Canada	1.68	1.60	0.42	0.17
Bangladesh	0.52	1.22	0.00	0.70
Pakistan	2.25	2.54	0.00	0.29
Brazil	0.51	2.49	0.00	1.98
India	10.55	14.01	0.00	3.46
United States	2.84	6.32	0.21	3.69
<b>World</b>	<b>76.39</b>	<b>76.39</b>	<b>21.86</b>	<b>21.86</b>

Source: IFA

## Feedstock

At its basis the urea industry's cost structure depends on feedstock prices. Ammonia is the basic building block to make urea, but there is very little urea capacity that exists as a stand-alone unit – for the most part it is produced in an integrated site alongside ammonia production, often because urea – as a bulk solid – is much easier to transport than ammonia, which must be refrigerated in order to liquefy it for shipping. Hence the feedstock market for urea tends to operate at one remove, with the natural gas or coal feed to ammonia production being the prime driver of production costs, and representing about 40-60% of urea production cost. Something like two thirds of all ammonia production is based on natural gas, with most of the remainder based on coal/coke gasification, and almost all of this in China. Merchant urea production has tended to gravitate towards cheaper gas locations such as the Middle East in recent decades, but the global gas market is changing rapidly as gas-on-gas competition begins to replace oil-indexed or controlled pricing, and gas availability is also now becoming a major factor, with the Middle East – outside of Iran – no longer having the amount of gas available as it used to as more and more gas based power production is developed. Nevertheless, as Table 1 shows, after China and Russia, the next four largest exporters of urea are all Middle Eastern nations – Saudi Arabia, Oman, Qatar and Iran – where historically cheap gas prices have led to considerable export-oriented capacity. The proximity of the Middle East to India, historically the largest importer of urea (although not quite in the year illustrated in Table 1), has been a major factor in advantaging the region over other exporters.

Non-merchant urea is for the most part concentrated in the countries with highest demand, China and India, where government policy has been to pursue self-sufficiency in urea production. However, this has been complicated in India by the expensive naphtha feedstock originally used for ammonia production, and while nearly all Indian urea plants have now switched to natural gas, lack of gas availability in India has prevented large-scale development of new capacity for the past two decades or so. China, meanwhile, has attempted to monetise its domestic coal reserves and used this as the basis of

Table 2: New urea capacity, 2016-20

Country	Plant	Location	Capacity, million t/a	Onstream
Azerbaijan	SOCAR	Sumgayit	0.6	2018
Bolivia	YFPB	Cochabamba	0.7	2017
China	8 new plants	Various	6.0 (offset by closures)	2016-17
Egypt	MOPCO	Damietta	1.2	2016
	Kima	Aswan	0.5	2019
India	Matix Fertilizers	Panagarh	1.3	2016
	Chambal	Gadepan	1.4	2019
Indonesia	Pusri	Palembang	0.4 (net)	2016
	Gresik	East Java	0.6	2018
Iran	NPC	Pardis	1.1	2016
	Shiraz	Marvdasht	1.1	2016
Malaysia	Petronas	Sabah	1.2	2016
Nigeria	Indorama	Port Harcourt	1.3	2016
	Dangote	Edo	1.3	2017
Russia	Phosagro	Cherepovets	0.5	2017
	KuybishevAzot	Kuybishev	0.5	2020
United States	Agrium	Borger, TX	0.6	2017
	CF Industries	Port Neal, IA	1.15	2016
	Dakota Gasification	Beulah, ND	0.3	2017
	Iowa Fertilizer (OCI)	Wever, IA	0.4 (net)	2016
	Koch	Enid, OK	0.8	2016

Source: Various

achieving self-sufficiency in urea production, aided at times by a high tariff barrier to export of urea. However, China has now over-built urea capacity, and become a major next exporter – the world's largest – with the export tariff gradually being relaxed as domestic supply was no longer an issue. In so doing, it has changed the nature of the urea market. Whereas previously high gas cost production in places like Ukraine was the marginal/swing producer and price setter, Chinese exports now tend to be the marginal supplier and Chinese coal costs have become the determinant of the urea market floor.

The other major factor which has changed global feedstock markets in the past few years has been the rapid expansion of unconventional gas production. In the US, this has taken the form of shale gas production, but a no less impressive expansion of unconventional production has occurred in Australia, where coal-bed methane production has boomed in recent years. Both of these countries are now slated to become major gas

exporters, with the bulk of all new LNG capacity over the next few years to be built in the US and Australia. In the US this has also brought down domestic gas prices to the point where domestic gas-based chemical production, including urea, has seen a major boost. As can be seen in Table 2, a significant proportion of urea capacity coming onstream over the next year or so is based in the US. In fact gross urea tonnage will be higher still, but much of it is destined for UAN production and will not impact upon urea markets.

## China

China has been the major investor in new urea capacity over the past decade, in an attempt to keep pace with domestic demand. Tens of millions of tonnes of new capacity have been added, about 70% of it based on coal feedstock. However, Chinese government policy is changing in this area, and this is likely to have a significant effect on the market in future. On the one hand, China has recognised the problem

caused by over-application of nitrogen fertilizer – particularly urea – at the expense of other fertilizers. China's nutrient use efficiency is considerably lower than North America or Europe, even though it uses much more fertilizer per hectare than those regions. It also faces a slower growing population, albeit one that is moving towards a diet higher in protein – more livestock rearing will make more manure available for farmers. The Chinese government decided in the most recent five year plan (2016-2020) to let nitrogen fertilizer demand rise only 1% per year to 2022, at which point it will be capped. Future productivity gains will come from more efficient application. At the same time, this will remove the need for additional domestic urea production. There is a policy in place now to modernise or close older, smaller units. IFA estimates that net production growth in urea to 2020 in China may be less than 1 million t/a, once closures are taken into account. The Chinese Nitrogen Fertilizer Industry reported that 9 million t/a of urea capacity closed in 2014-15, and another 10 million t/a is slated for closure. While this will still leave China oversupplied and a major net exporter, it means new investment in urea capacity – outside of revamps – is likely to be outside of China.

China seems set to play the role of swing capacity for the coming years, with Chinese coal prices tending to set a price floor. Although much new Chinese capacity is designed to run on cheaper, bituminous coal rather than more expensive anthracite, or take feed from coke oven gas or other sources, coal prices have been rising in China, and may gradually push urea prices upwards over the next couple of years.

## India

India remains the country with the largest deficit in urea, importing several million tonnes per year – around one third of its requirements. The country's urea consumption is complicated by a subsidy scheme which has decontrolled the prices of all fertilizers except urea, leading to nutrient imbalances in application. However, the government is now attempting to move to direct subsidies to farmers, as described in our article earlier this year (*Nitrogen+Syngas 341*, pp20-24). At the same time, the government is trying to boost domestic production by revamping and reopening old, closed plants and allowing the construction of new plants. At

Table 3: Urea production and consumption and net surplus/deficit by region, 2014, million tonnes N/year

Region	Production	Consumption	Surplus
Western Europe	2.84	4.56	-1.72
Central Europe	1.48	1.55	-0.07
FSU	5.50	2.17	+2.35
North America	4.52	7.91	-3.39
South America	1.94	5.48	-3.54
Africa	2.07	2.37	-0.30
Middle East	8.95	2.40	+4.55
South Asia	13.32	17.94	-4.62
East Asia	35.53	30.71	+4.82
Oceania	0.26	1.29	-1.03

Source: IFA

the moment, only one new fertilizer plant is under construction in India – Matix Fertilizer in Bengal, which is using coalbed methane as feedstock. There are a dozen other projects under development, but allocation of gas will be crucial to whether the project is able to proceed or not, and many Indian companies are looking overseas to see if capacity can be developed there, with Iran and various locations in Africa under consideration. For the moment, it looks as though India will remain the main importer.

## New investment

With prices low and the industry suffering from overcapacity following the previous investment cycle, the conditions for building new urea plants are not as rosy as they have been previously, and most of the plants in Table 2 are the tail end of this investment cycle. As can be seen, China and the US remain the largest destinations for new capacity, with Iran, southeast Asia and Russia, Egypt, Nigeria and also India also seeing capacity growth. Overall, global urea capacity is expected to reach 163 million t/a in 2020, according to IFA. Beyond this timeframe, there are large new projects under development in Russia and Africa, but financing may well depend on urea prices coming back up from their current doldrums.

Sub-Saharan Africa is the only place where there is 'stranded' gas on any significant scale – in countries like Mozambique and Tanzania. There is also still considerable flared gas available in Nigeria. However, the fall in oil prices has meant that the large LNG projects which often drive investment with associated ammonia/

urea capacity have been postponed or otherwise found funding difficult.

## Urea trade

Because of the large volumes of urea produced in major consuming markets, especially India and China, international trade in urea makes up a relatively small proportion of the total urea market – about 28%. Table 3 shows the major exporting and importing regions as of 2014, although this masks some intra-regional trade, for example from Indonesia to Vietnam or Canada to the USA. Other regions can almost be considered as appendages of a larger market. For example the Caribbean is mainly an adjunct to the US market, the Middle East is closely tied to the South Asia market, and North Africa is very closely tied in with the European market.

The largest changes in Table 3 over the past few years have been the change of East Asia from a net importing to exporting region as Chinese urea overcapacity pushed more urea onto the market. Consumption has risen in North and South America and the FSU – in the latter case, coupled with the fall in Ukrainian production, net FSU exports have dropped by over a million t/a over the past five years. South American consumption, especially in Brazil, has increased very significantly over the past few years. Going forward, increases in domestic US production are likely to progressively edge out imports, to the tune of perhaps 3 million t/a (ca 1.4 million tonnes N), and it seems likely that much of this will be chasing buyers in South America. ■



## Pioneering with a higher purpose to enable the world to feed itself



Stamicarbon can help you to optimize the performance of your existing plant in all manner of ways. From production improvements, monitoring and detection to tailored staff training and full life cycle support. With our ADVANCE series you can maintain a competitive edge for the entire operational life of your plant – and even extend its longevity resulting in a better return on your investment.

For more information about our services, please visit: [www.stamicarbon.com](http://www.stamicarbon.com)

The innovation & license company of Maire Tecnimont.



## CONTENTS

What's in issue 344

## COVER FEATURE 1

Advances in platinum gauzes

## COVER FEATURE 2

Urea markets

## COVER FEATURE 3

Olefins drive methanol expansions

## COVER FEATURE 4

Integration of ammonia/urea plants

NITROGEN+SYNGAS  
ISSUE 344  
NOVEMBER-DECEMBER 2016

BCInsight

Southbank House, Black Prince Road  
London SE1 7SJ, England  
Tel: +44 (0)20 7793 2567  
Fax: +44 (0)20 7793 2577  
Web: [www.bcinsight.com](http://www.bcinsight.com)  
[www.bcinsightsearch.com](http://www.bcinsightsearch.com)



# What's new in nitric acid and AN?

The Chemelot site at Geleen, home to OCI Nitrogen.

A report on new developments at this year's Ammonium Nitrate and Nitric Acid (ANNA) producers' meeting, held in Eindhoven in late September.

Since its first successful move across the Atlantic six years ago, the ANNA meeting has come to Europe every three years, and this year the turn of hosting it fell to OCI Nitrogen – formerly DSM Agro – based in the Netherlands. Attendance for the past three years has averaged around 400, and this year saw 420 delegates registered, showing that the meeting continues to remain a popular forum for the nitric acid and ammonium nitrate industries.

## Regulatory issues

AN is always high on the agenda of regulators, and as this year the meeting was hosted in Europe it fell to Antoine Hoxha of Fertilizers Europe to report on the progress of legislation potentially affecting the AN industry. The first thread comes from the EU's Directorate General (DG) 'Clima', which has been set the goal of reducing EU carbon and carbon equivalent emissions by 80-90% by 2050. So far the focus has been on reduction of nitrous oxide from nitric acid plants, with a benchmark of 0.974kg/tonne HNO<sub>3</sub>, and having to pay for emissions above this level, which has led to an 85% reduction in N<sub>2</sub>O emissions from 2005-2015. DG Clima is now preparing the 2021-2030 emissions

trading scheme. There are likely to be fewer free allocations of carbon permits and CO<sub>2</sub> prices are likely to increase, but as carbon pricing spreads internationally, there is hope that the EU industry will find itself already advantaged in this regard.

Meanwhile, a new regulatory framework for sustainable fertilizer production, focusing on the 'circular economy' is expected in 2018, which will require much larger scale recycling of nutrients. This will lead to competition with established fertilizers and probably lower consumption, but possibly new opportunities for innovative blends, purification and recycling technologies and new nutrient sources. There is also a new approach to 'best available techniques' which is aiming to take a 'cross-sector' approach on issues such as dust control, which may necessitate some process improvements. Finally, there is a German proposal circulating on nitric acid inhalation toxicity which could see concentrated nitric acid move up to higher toxicity classes than the current levels.

## Safety and security

The safety section of the meeting was greatly enlivened by a live demonstration by Rene Hoekstra of BASF of some of the

hazards involved in handling flammable gases, liquids and dusts, vividly demonstrating the effect of aerosols and absorbents, upper and lower explosion limits, mixtures of previously safe liquids and the effect of turbulent flow in pipelines.

Fertilizers Europe consultant Kish Shah, a regular at these meetings, focused this time on fertilizer blends and compound fertilizers containing AN. The main potential hazard is self-sustaining decomposition even after the removal of a heat source and absence of air, exacerbated for mixtures with potassium chloride by the catalytic effect of chlorine. Especial care must be taken when changing formulations or deviations in composition, and dealing with off-spec or reject material. The explosion risk is relatively low, mainly associated with heating in confinement, and so hot work such as welding must be strictly controlled and ventilation maintained.

Dr Nicolas Diaz of thyssenkrupp Industrial Solutions reviewed literature concerning AN/CAN properties and storage, covering caking and hygroscopic behaviour, dust formation, and handling and storage parameters, and Borealis discussed work conducted on common safety standards for AN solution pumps, having discovered that across their 9 plants in six locations differ-

ent standards were in effect. The methodology has concentrated on inserting trips or design features to prevent the combination of high temperature, high pressure (no flow), low pH and contamination which can lead to unsafe operation.

The Pentagon's Joint IED Defeat Organization (JIEDDO), now rebranded as JIDA – the Joint Improvised Threat Defeat Agency – reviewed its efforts to reduce the threat posed by AN-based improvised explosives. The agency has recorded 15,000 IED incidents in the past year alone, mainly in Iraq, Syria, Afghanistan and Colombia, with bomb-making know-how now easily spread via the internet. In attempting to reduce terrorist access to precursor materials like AN, JIDA is partnering with other agencies such as IFA and the IME (International Makers of Explosives) – in the latter case to develop a harmonised system of marking for commercial grade explosives, in the former case to develop the Protect and Sustain audit process for improving safety, security and sustainability at all stages of the AN manufacturing and distribution process.

The fire department of the Chemelot industrial park at Geleen in the Netherlands reported on their handling of a serious fire at the OCI Nitrogen CAN plant at the site in November 2015, including having to deal with underground passages where fire had spread to the conveyor system.

Enaex in Chile suffered an explosion in a line feeding their AN solution prilling plant in 2014 which resulted in an operator suffering perforated eardrums – fortunately that was the extent of his injury as the explosion threw debris up to 300m. Investigation found a fouled additive line had led to a pressure build-up, high temperatures and subsequent decomposition of AN.

## Testing and instrumentation

Sandia National Laboratories shared some work they have been conducting on developing instrumentation for characterising shock development in granular non-ideal ideal explosives as a function of input shock magnitude. They have been using a fibreoptic system and a distant high speed camera to measure the precise time of shock arrival at many discrete locations throughout the explosive charge, and correlating this with embedded piezoelectric pins. The test method is still under development but has shown promising results so far.

Yara reported on an ammonia release from atmospheric storage at the company's

Rostock facility. Condensation had frozen and forced partially open a safety valve but this was not detected until complaints from local residents were reported to authorities. Yara has been improving ammonia detection at the site and using a scanning IR gas imaging system at two positions to triangulate detected ammonia concentrations and trip an alarm where appropriate.

Ammonia detection was also the topic of Kevin Dean of Senescent, looking at how Enhanced Laser Diode Spectroscopy can be used in pen path detectors along pipe racks and perimeters to cover release scenarios which fixed point detectors cannot deal with.

UAN solutions have a known issue with corrosion. OCI has been looking at ways of ameliorating this using a corrosion inhibitor using an automated dosing system at their barge loading facility in the Netherlands, using 3D TRASAR technology.

## Environment

In a review of their environmental permit for operating their AN plant, OCI were told to reduce AN dust emissions to less than 5mg/m<sup>3</sup>, from the previous level of 150mg. The company found that the majority of fine dust emissions were coming from the off-gas washer, where free NH<sub>3</sub> and nitric acid were reacting to form tiny AN particles. High efficiency filters, although not proven for AN, seemed the only potential solution, and tests have so far proved encouraging. The company is also redesigning the off-gas washer to eliminate fugitive ammonia and nitric acid.

Arionex reported on a new waste water treatment plant they installed for Azomures in Romania in order to meet new, more stringent concentration restrictions on ammonium and nitrate ions in discharge water, via steam stripping and ion exchange systems, which have not only met the new limits but allowed recovery of an 18-25% AN solution.

Eurochem at Novomoskovsk have installed MECS Brink mist eliminators as part of an overhaul of their AN plant as it moved from LDAN to HDAN production, and have reduced AN emissions to less than 10mg/m<sup>3</sup>, well below their allowance of 50mg.

## UAN

Weatherly – now part of KBR – offered an overview of their UAN technology. Being

able to offer urea, nitric acid, ammonium nitrate and UAN licenses, they have integrated all together with the total recycle urea plant, feeding high pressure urea off-gas to the nitric acid plant, low pressure urea off-gas to the ammonium nitrate plant and urea solutions to the UAN plant, bringing down overall cost and energy consumption.

KBR Weatherly also used the conference to showcase its new Weatherly Dual Pressure Nitric Acid Technology – more on this can be found in our Nitrogen Industry News section on page 10.

## Corrosion

In the nitric acid section of the conference, Christof Group discussed the applications of steel 1.4361 – a silicon bearing stainless steel with strict demands on chemical composition and microstructure – in the most demanding, highly concentrated nitric acid applications. The improved corrosion resistance is a result of formation of a thin protective silicon dioxide layer on top of the passive chromium oxide layer, but to optimise the corrosion resistance of the steel adapted welding techniques with adapted filler materials are required. Water cooling during welding has to be applied, to avoid solution annealing after welding.

## Pumps and compressors

Yara reported on a nitric acid pump failure, which led to a rupture and spill at their Porsgrunn plant. Investigation revealed that the pump casing suffered from a brittle, mechanical cleavage fracture, with a combination of stress, pressure and low temperature finally leading to failure. The fault was found to be in the material itself – the specification dated back to the 1970s and apparently had not evaluated the mechanical properties. Replacement of the pump casing – and those of three similar pumps, with austenitic 304L stainless steel is ongoing.

Prognost considered a reciprocating nitric acid compressor, and whether monitoring of crank case vibration provides sufficient warning of failure. Crosshead vibration monitoring reduces the risk of loss of mechanical integrity, but the rod position can detect development of certain reciprocating failure modes earlier than crosshead vibration and can greatly reduce consequential damage. ■

## CONTENTS

What's in issue 344

## COVER FEATURE 1

Advances in platinum gauzes

## COVER FEATURE 2

Urea markets

## COVER FEATURE 3

Olefins drive methanol expansions

## COVER FEATURE 4

Integration of ammonia/urea plants

NITROGEN+SYNGAS  
**ISSUE 344**  
NOVEMBER-DECEMBER 2016

**BCInsight**

Southbank House, Black Prince Road  
London SE1 7SJ, England  
Tel: +44 (0)20 7793 2567  
Fax: +44 (0)20 7793 2577  
Web: www.bcinsight.com  
www.bcinsightsearch.com





Inspired by  
*The School of Athens*, Raffaello Sanzio 1509-1511  
Vatican Museums. Photo Scala Archives

AMMONIA  
NITRATES & PHOSPHATES  
UREA  
MELAMINE  
METHANOL  
SYNGAS

## A FULL RANGE OF TECHNOLOGIES AND SERVICES

 **CASALE**  
casale.ch

CONTENTS

What's in issue 344

COVER FEATURE 1

Advances in  
platinum gauzes

COVER FEATURE 2

Urea markets

COVER FEATURE 3

Olefins drive  
methanol  
expansions

COVER FEATURE 4

Integration of  
ammonia/urea  
plants

NITROGEN+SYNGAS  
**ISSUE 344**  
NOVEMBER-DECEMBER 2016

## BCInsight

Southbank House, Black Prince Road  
London SE1 7SJ, England  
Tel: +44 (0)20 7793 2567  
Fax: +44 (0)20 7793 2577  
Web: [www.bcinsight.com](http://www.bcinsight.com)  
[www.bcinsightsearch.com](http://www.bcinsightsearch.com)



China's first 1.7 million t/a coal to olefins plant, Shantou Baotou, which began production in 2010.



# Olefins the key driver for methanol

The Argus Jim Jordan & Associates (JJ&A) Methanol Forum in Houston in September discussed the continued remarkable growth in demand in the methanol market, now up to 78 million t/a in 2015, with China, and especially Chinese methanol to olefin production the main market.

Methanol markets are continuing to grow, although growth forecasts have been revised downwards since last year, noted Argus JJ&A analyst (and former *Nitrogen+Syngas* correspondent) Dave McCaskill. Even so, meeting incremental methanol demand still requires two world scale plants per year on average. Dave forecast an AAGR for the methanol industry of 9% out to 2020, with strong growth in fuel sectors and methanol to olefins. New production is continuing to come on-stream in China, the US and Iran in particular, with the US transitioning from a net importer to exporter. Europe, SE Asia and India are net importers, and China remains the 'catch basin' for all excess methanol. Methanol to olefins production is now regarded as the incremental demand driver for methanol demand, with olefin affordability increasingly representing a ceiling for methanol

pricing. There is potential for methanol export from the US to China for MTO production, as proposed by Northwest Innovation (see *Syngas News*, this issue), but the cash costs are more finely balanced than one might think, Dave said.

## China

The biggest story in methanol has been China's explosive growth in demand, initially for fuel uses, but now more particularly for olefins production. Wenran Jiang of the Canada-China Energy and Environment Forum explained the reasons for this – China's rapidly growing economy and declining oil and gas production (or at least declining as a proportion of total consumption), leading to increasing dependency on foreign oil. China is particularly worried about strategic choke point such as the Malacca Straits, through which 80% of its imported

oil travels, and the potential for an aggressor to interdict that. Domestic coal has been seen as a way of balancing this import dependence, and led to coal-based methanol and derivatives such as DME and MTBE becoming fuel substitutes. Chinese growth in methanol demand is forecast to slow, from its breakeven growth of 16% per year to "only" 6% per year, but this will still see another 10 million t/a of demand out to 2020. Fuel uses now account for 45% of Chinese methanol demand, but olefins are now 20%, from nothing just a few years ago, and are the fastest growing area. Chinese methanol production has flattened out, and the excess is now being made up with imports, forecast to rise from 7 million t/a at present to 19 million t/a by the end of the decade. Chinese imports came mainly from Iran last year (44%), with Oman, New Zealand and Saudi Arabia all supplying 11-14% each.

The growth in methanol as a fuel has come mainly from some regional, provincial governments, rather than from the central government, and national fuel standards for M15 and M85 are still pending, after opposition from the large national oil companies which compete for the fuel market share. However, in spite of the slowing economy, there are still push factors for methanol demand in China,

from a renewed focus on environmental emissions to increasing vehicle use. But challenges, especially at national policy level, remain.

Becky Zhang of Argus JJ&A turned specifically to that growing olefins sector in China. Coal to olefins and methanol to olefins account for 17 million t/a of methanol in China alone, and are collectively forecast to represent 30% of China's olefins capacity by 2020. Table 1 shows the plethora of new projects which are still under development over that timescale. MTO margins, she said, were still lower than other competing technologies in China, in spite of falling feedstock prices, but coal to olefins producers were losing competitiveness to naphtha crackers on lower crude prices (CTO is less competitive when crude is below \$50/bbl), and coastal MTO merchant suppliers are highly cost sensitive.

Olefins markets, covered by Argus JJ&A's Paige Morse, are driven by competitive feedstock advantage. The US currently has an advantage courtesy of shale gas in ethane-based production to ethylene and polyethylene, and is taking over from the Middle East as the main destination for new PE investment. However, polyethylene capacity is growing faster than demand and the market is weakening. Polypropylene production is seeing a move towards on-purpose production, with propane dehydrogenation the main source, but PDH can be challenging to operate and is often aimed at the merchant market and hence vulnerable to price changes, and coal to olefins and methanol to olefins growing rapidly.

## North America

Brad Gunn of US Methanol looked at the prospects for methanol in the US and North America. Shale gas has obviously changed everything for US methanol producers, and in 2015 US capacity doubled from 2.75 million t/a to 5.8 million t/a, with several more plants in the planning and development phase. With more than 10 million t/a on the drawing board, the US is forecast to be self-sufficient in methanol by 2018, and a net exporter from 2020 – US demand for methanol is forecast to be 9.9 million t/a in 2020. It could easily take over as a regional exporter from Trinidad. Increased MTO production in China will be able to absorb some of this US production, but only if oil prices rebound. Lower crude prices have also impacted on the growing area of methanol fuel uses.

Table 1: New Chinese methanol to olefins and coal to olefins plants

Producer	Location	Methanol consumption	Start-up
<b>Current MTO production</b>	<b>Various (12 plants)</b>	<b>11,160,000 t/a</b>	<b>To June 2016</b>
<b>Current CTO production</b>	<b>Various (7 plants)</b>	<b>12,360,000 t/a</b>	<b>To June 2016</b>
Shenhua Coal New Mats	Urumqi, Xinjiang	1,800,000 t/a (CTO)	Oct 2016
Zhongtian Hechaung	Ordos, Mongolia	1,800,000 t/a (CTO)	Oct 2016
Qinghai Salt Lake	Haixi, Qinghai	1,000,000 t/a (CTO)	4Q 2016
Huating Coal	Pingliang, Gansu	600,000 t/a (CTO)	4Q 2016
Changzhou Fund Energy	Changzhou, Jiangsu	990,000 t/a (MTO)	4Q 2016
Zhongtian Hechuang	Ordos, Mongolia	1,800,000 t/a (CTO)	early 2017
Shaanxi Yanchang	Yan'an, Shaanxi	1,800,000 t/a (CTO)	mid-2017
Jiangsu Sailboat	Lianyungang, Jiangsu	2,400,000 t/a (MTO)	1H 2017
Zhong'an Utd Coal	Huainan, Anhui	1,800,000 t/a (CTO)	2H 2017
Jiutai Energy	Ordos, Mongolia	800,000 t/a (MTO)	2H 2017
Shenhua Baotou	Baotou, Mongolia	1,800,000 t/a (CTO)	4Q 2017
Shanxi Qiyi Energy	Xiangyang, Shanxi	900,000 t/a (CTO)	4Q 2017
Shanxi Coking Co	Hongdong, Shanxi	1,800,000 t/a (CTO)	2018
Sinopec/Henan Coal	Hebi, Henan	1,800,000 t/a (CTO)	2018
Qinghai Mining	Golmud, Qinghai	1,800,000 t/a (CTO)	2018
China Coal Yulin Energy	Yulin, Shaanxi	1,800,000 t/a (CTO)	2018
Jilin Connell Chemicals	Jilin, Jilin	600,000 t/a (MTO)	2018
Tianjin Bohua	Tianjin	3,600,000 t/a (MTO)	2019-20
Fujian Gulei Petchem	Zhangzhou, Fujian	1,800,000 t/a (MTO)	2020
<b>Total new MTO</b>		<b>11,990,000 t/a</b>	
<b>Total new CTO</b>		<b>20,500,000 t/a</b>	

Source: Argus JJ&A

Is the US overbuilding capacity? Brad suggested that challenges for Caribbean producers – gas shortages in Trinidad and unrest in Venezuela – could be a US opportunity, while an important area to watch is derivatives growth in the US. Lower methanol prices will make end use products more competitive. There could be new applications, like fuel blending, and scope for smaller scale, distributed US production. US Methanol is planning to build smaller (100-150,000 t/a) plants at or near customer sites on the Atlantic and East Coasts and in the mid-West, hoping to cut out shippers and transporters margins.

## DME

Dimethyl ether (DME) has often been seen as a promising use for methanol, but there has been no major development so far outside of China, where the industry has suffered from over-investment due to wildly optimistic estimates of potential demand, and accidents caused by the

CONTENTS

What's in issue 344

COVER FEATURE 1

Advances in platinum gauzes

COVER FEATURE 2

Urea markets

COVER FEATURE 3

Olefins drive methanol expansions

COVER FEATURE 4

Integration of ammonia/urea plants

NITROGEN+SYNGAS  
**ISSUE 344**  
NOVEMBER-DECEMBER 2016

**BCInsight**

Southbank House, Black Prince Road  
London SE1 7SJ, England  
Tel: +44 (0)20 7793 2567  
Fax: +44 (0)20 7793 2577  
Web: www.bcinsight.com  
www.bcinsightsearch.com

fuel the vehicle trial there, and has more installations planned.

**Biodiesel**

Methanol's use to esterify vegetable oils to make biodiesel fuel is a use that has grown particularly in Europe, but there are other areas which are seeing interest. Scott Fenwick of the US National Biodiesel Board reported on US use of biodiesel. Use has climbed steadily, now reaching 2.1 billion gallons in 2015 (over 6 million t/a, equivalent to 600,000 t/a of methanol), outpacing domestic supply and requiring 25% to be imported. Under the Renewable Fuel Standard, the US Environmental Protection Agency is projecting that biodiesel requirements will be 2.5 billion gallons in 2016 and 2.7 billion gallons in 2017.

Brazil has traditionally been an ethanol-fuelled economy, using ethanol derived from sugar cane, but Jose Oswaldo Fernandez of Mitsubishi showcased the country's growing biodiesel programme, using the waste from soybean cultivation and processing. There are now 51 biodiesel producers in Brazil, with a total of 7.2 million m<sup>3</sup> of capacity (4,300 t/a), and a rising mandate which now specifies that 7% of Brazilian diesel must contain biodiesel as a blend this year, growing to 10% in 2019, and potentially 15% beyond that, with blends of 20 and 30% approved for voluntary use. A 30% blend across the board would, Jose noted, allow Brazil to meet 80% of its agreed carbon reductions by 2030.

**MTBE**

David Dennison of LyndellBasell discussed drivers for the MTBE market, including increasing gasoline consumption worldwide, and tightening sulphur restrictions which require increasing higher octant components to balance the blend. While other octane boosters like alkylate and toluene are also available, Dennison estimated that if the US used solely MTBE to meet new Tier 3 fuel regulations, that would represent up to 6 million t/a of extra demand. While MTBE is still in bad odour in the US following the backlash in the 1990s caused by leaching into water-courses from leaking underground fuel tanks, global MTBE use is rising, especially in China, and it is forecast to grow at 3% year on year over the next five years, reaching 25 million t/a in 2020. Around

3.7 million t/a of capacity additions are planned, mainly in China, but including a 1 million t/a plant in the US being developed by LyondellBasell.

**Other fuel uses**

While methanol's direct fuel use is mainly limited to vehicles in China, there is increasing interest in using methanol as a shipping fuel. Shipowners are facing increasing restrictions on the sulphur and NOx output from their vessels, especially in spreading Emissions Control Areas (ECAs) – currently confined to the North and Baltic Seas and east and west coast of North America, as well as some coastal regions of China, but soon to spread to the Mediterranean, and possibly coastal areas around Korea, Japan, Singapore, Mexico and Norway. Jason Chesko of Methanex argued that methanol reduces ship emissions by 99% in the case of sulphur oxides, 60% for NOx and 95% for particulate matter, as well as being cheap and readily available, and requiring far less conversion than LNG. Methanex run several methanol fuelled vessels and Stena Line have a Baltic ferry that is methanol fuelled.

Greg Dolan of the Methanol Institute reviewed the public policy issues around use of direct methanol blending into fuel. While China has paved the way here, there are now policy initiatives in Iceland, India, Egypt, New Zealand, Australia, Denmark and Israel, and considerable interest elsewhere. China now has 150,000 vehicles fitted to run on 100% methanol, and methanol as a blendstock represents 10% of the gasoline market. Israel is progressing towards an M15 blend use, and Australia an ethanol-methanol mix. As well as the marine fuel use discussed above, there are also initiatives in areas such as cooking stoves in developing countries, turbine and boiler fuels and fuel cells.

**Formaldehyde**

Formaldehyde remains the main chemical derivative of methanol, as examined by Julian Morris of Johnson Matthey – licensors of the Formox process used to make around 30% of formaldehyde globally. Formaldehyde consumption is strongly linked to GDP growth, and so growth is likely to be focused on Asia, Africa, South America

and the Middle East over the coming few years. The main uses are in resins for wood products, and as a chemical intermediate. JM predicts steady 3.5-4.5% growth per annum, with the chemical intermediate sector seeing the strongest growth at up to 6% AAGR in spite of the slowdown in the Chinese economy and overcapacity in that market.

**European methanol**

Western Europe represents 8.6% of global methanol demand, according to Roel Salazar of Argus JJ&A. The major source of demand is formaldehyde, representing 43% of consumption, with fuel uses next, specifically biodiesel production and MTBE, which account for 19% and 14% respectively of demand. While the market is mature, and growth largely GDP-related, Argus JJ&A does predict growing fuels use for methanol – biodiesel has been the fastest growing segment of over the past 10 years – although MTBE use is in decline as Europe finds it increasingly difficult to export its gasoline surplus. Germany is the main centre of demand, with 44% of all consumption, averaging 2.5 million t/a. Production is more limited, at around 2.7 million t/a from six facilities, again mainly in Germany, and imports make up 75% of the 10.5 million t/a of demand, coming from Trinidad, Equatorial Guinea, the Middle East and Eastern Europe. It seems likely that US exports will come to represent a growing share of European imports over the next few years.

Greg Dolan of the Methanol Institute reviewed the public policy issues around use of direct methanol blending into fuel. While China has paved the way here, there are now policy initiatives in Iceland, India, Egypt, New Zealand, Australia, Denmark and Israel, and considerable interest elsewhere. China now has 150,000 vehicles fitted to run on 100% methanol, and methanol as a blendstock represents 10% of the gasoline market. Israel is progressing towards an M15 blend use, and Australia an ethanol-methanol mix. As well as the marine fuel use discussed above, there are also initiatives in areas such as cooking stoves in developing countries, turbine and boiler fuels and fuel cells.

**Small-scale production**

Traditional world-scale methanol plants use primarily natural gas or, in China, coal, but there is considerable potential or methanol production from alternative feedstocks, and this requires a different scale of plant – smaller and more modular. George Boyajian of Primus Greene Energy discussed the possibility for methanol production using stranded gas or gas liquids or associated gas as part of his firm's Syngas to Liquids or Syngas to Gasoline (STG) process, which uses methanol as an intermediate step. There is a fuller discussion, based on refinery hydrogen as feedstock, elsewhere in this issue.

30<sup>th</sup>

Syngas | Ammonia | Urea | Nitrates | Methanol | GTL | Hydrogen

**CRU Nitrogen + Syngas 2017**



27 Feb - 2 March 2017  
Hilton London Metropole, London, UK

Promoting and developing best practice and innovation in the global nitrogen industry

**5 great reasons to attend:**

- ✓ **Develop** practical solutions to operational problems through detailed case studies
- ✓ **Learn** about the latest technological and process innovations
- ✓ **Share** operational best practice and experiences with peers
- ✓ **Understand** the global and regional market drivers for 2017 and beyond
- ✓ **Network** with **700+** technical and commercial peers from **50+** countries

**Perfect conference with excellent networking opportunities.**

Harrie Duisters, Technology Director, OCI Fertilizers

**Key conference themes for 2017:**

The **technical programme** will cover the full nitrogen value chain including syngas, ammonia, urea, nitrates and finished fertilizers. Given the current market environment for nitrogen producers, the agenda will have a particular **focus on improving operational efficiency and enhancing performance and output.**

Subject areas will include:

- Improving reformer performance, operations, reliability and safety
- Ammonia revamps, modernizations and capacity increases
- Ammonia projects and commissioning case studies
- Improving ammonia plant performance, operations and efficiency
- Best practice urea operations
- Urea process enhancements
- New developments in fertilizer finishing and granulation
- Optimisations and efficiency enhancements in the production of nitrates

**Commercial themes** to be explored will include:

**The CRU View:** Nitrogen costs in a supply-driven market, and an overview of the Chinese nitrogen market. Additional commercial topics will give delegates insight into global market trends and will include: Outlooks for natural gas; Changing farmer needs for fertilizer: opportunities for N producers; and a Freight market outlook.

**Sponsors:**



**Official publications:**



**Supporting publications:**



**Supporting partners:**



For more information and to book your place, visit [www.nitrogensyngas.com](http://www.nitrogensyngas.com)

**CONTENTS**

What's in issue 344

**COVER FEATURE 1**

Advances in platinum gauzes

**COVER FEATURE 2**

Urea markets

**COVER FEATURE 3**

Olefins drive methanol expansions

**COVER FEATURE 4**

Integration of ammonia/urea plants

**NITROGEN+SYNGAS**  
**ISSUE 344**  
NOVEMBER-DECEMBER 2016

**BCInsight**

Southbank House, Black Prince Road  
London SE1 7SJ, England  
Tel: +44 (0)20 7793 2567  
Fax: +44 (0)20 7793 2577  
Web: [www.bcinsight.com](http://www.bcinsight.com)  
[www.bcinsightsearch.com](http://www.bcinsightsearch.com)





# Putting safety first

The Safety in Ammonia Plants & Related Facilities Symposium took place this year in Denver 18-22 September 2016. Ammonia producers from across the globe gathered to share their experiences and benefit from lessons learned in the industry.

Approximately 400 engineers, operators and industry experts gathered in Denver in September for the 61st AIChE Annual Safety in Ammonia Plants & Related Facilities Symposium. This year's keynote address took on a new format with a lively and interactive address from Paul Sovinski of Stars International who provided a 'mini workshop' on process safety leadership. He stressed that safety awareness and taking responsibility for safety should be an integral part of company philosophy across all levels of management and workers. The key leadership principles for being a safety leader were summarised as being someone who:

- Continuously builds relationships of trust;
- Takes shared responsibility for the choices the people who live and work with them, especially regarding safety and productivity;
- Communicates effectively – listens well, speaks well and adapts to the need of others;
- Gives clear expectations and reinforces positive performance
- Handles safety issues and conflict directly, honestly and professionally.

## Risk assessment and safety strategies

Yara and Incitec Pivot discussed safe operation in chemical plants with Stop Work Authority (SWA). Although SWA policy exists in the chemical industry it is not well understood and the exercise of stop work or plant shutdown action, prior to or during abnormal situation, requires major policy improvement. Stop work policy statements need to be augmented with clear prescriptive guidelines for consistent and systematic actions. The current status of SWA as practiced in various major companies was reviewed and typical guidelines for plant operation teams to act in

safe shutdown of the plant to minimise safety and reliability issues such as delays in bringing down the plant as needed were shared.

Asean Bintulu Fertilizer (ABF), a subsidiary of Petronas, in Malaysia shared their experience of Dynamic Risk Analyzer™ (DRA™), new software based on proprietary predictive risk analysis from Near-Miss Management. DRA allows the operating team to assess the risk level of its plant operations and identify early indicators of developing risks daily. As a result, processes are operated with reduced risk profiles and improved capital effectiveness. ABF adopted the DRA system at their facility in December 2014. Since then ABF has improved its organisational culture and workflow that involve day-to-day proactive assessment of process risks at their early stages.

Baker Engineering & Risk Consultants discussed toxic gas detection in ammonia plants, in order to protect personnel and equipment, and the importance of toxic Shelter-In-Place (SIP) or toxic safe havens as part of a strategy to manage risks from toxic releases. Various gas technologies are available to strengthen the SIP by providing much needed data in the form of gas concentrations at various locations within the plant and also within the SIP to prevent personnel from evacuating when it is safer in the SIP, or to ensure that occupants evacuate when necessary.

The recently released Center for Chemical Process Safety (CCPS) "Guidelines for Initiating Events and Independent Protection Layers for Layers of Protection Analysis (LOPA)" has generated a new round of discussion regarding the amount of credit that can be taken from a DCS. In a separate presentation, on validating (or not) multiple LOPA credits from your DCS, Baker Engineering and Risk Consultants identified some specific considerations and methods of validation that end-users can consider.

One of the largest risk exposures to any ammonia plant is damage to critical unsparred items of large rotating equipment such as ammonia and syngas compressors. There have been several losses in industry caused by mechanical failure and fires on these types of equipment and on similar items in other related industries. Insurance covers losses from these events, such as the property damage and associated business interruption (loss of profits), but does not cover the ensuing loss of market share and/or damage to reputation. Zurich Insurance Company suggested a risk-based philosophy for the determination of fire protection and/or detection of critical machines, rather than a prescriptive approach. To achieve this objective a risk-based decision tool was recommended.

Borealis Group presented a paper on integrated safety concepts for rotating machinery. With the development of modern Emergency Shut Down (ESD) systems and HAZOP studies, questions have been raised, how the hazard coming from rotating equipment should be treated in plant hazard studies to develop an integrated process safety approach. Borealis reviewed a number of safety relevant scenarios for centrifugal compressors and proposed safety concepts, which were discussed with reference to learning from incidents.

Johnson Matthey Process Technologies described various Environment, Health and Safety (EHS) assurance techniques and technology risk assessments they carry when developing new processes, such as Johnson Matthey's innovative ammonia-methano-UFC co-production process.

In a separate paper Johnson Matthey discussed the importance of appropriate risk assessment tools to ensure the safe operation of process units. Where a new or improved catalyst is involved, further tools

such as a reactive hazard assessment or technical risk assessment should be used.

Ammonia plant failures and incidents An important part of the Ammonia Safety Symposium programme is the sharing of information with regard to plant failures and incidents so that similar events can be prevented in future.

CF Industries discussed welding problems experienced while attempting to weld the outlet pigtailed into the sockets on the ammonia plant primary former hot collectors. Defects began to appear in the hot collector sockets. Multiple weld techniques and pre-heat temperatures were adopted without success. After discussions with manufacturers and metallurgist it was decided to solution anneal the hot collectors, which resulted in a significant shutdown overrun. The investigation concluded that the problems were caused by an unusually rapid cooling event (reformer trip) in 2013 very soon after plant start up with new hot collectors.

Incitec Pivot and Quest Integrity reported on the failure of a secondary reformer dome and its repair. Examination of the failed dome revealed that bricks had primarily sheared at an angle close to 90 degrees to the major axis of the dome. It was concluded that the refractory dome failed as a result of high thermal stresses introduced as a result of the different thermal expansion between the refractory brick dome and the water cooled vessel shell. The design had no allowance for thermal expansion. The dome was replaced with a novel design using readily available alumina blocks.

A paper by Sitech Services described investigations into some failures affecting aging ammonia plants of OCI Nitrogen in Geleen, The Netherlands, namely: failure of reformer inlet piglets, failure of a riser between the waste heat boiler and the steam drum, and crack indications at the transition between the reformer/riser tubes and the weldolet of the outlet header. Each case was discussed and lessons to be learned shared. The failures could be related to the aging of the plants in combination with an underestimation of the impact of certain failure mechanisms.

Yara Trinidad reported on a release of Benfield solution hot potassium carbonate) and syngas from the level bridle of the CO<sub>2</sub> absorber on the Tringen 2 ammonia plant which resulted in a plant shutdown and subsequently a fire. The paper looks at the failure mechanism, shortcomings in the HAZOP for the site and difficulties

experienced at the time of the incident when containment and isolation was key in reducing damage.

Misir Fertilizer Production Company, Egypt, shared their experience of a syngas compressor hydraulic thrust bearing failure. The syngas centrifugal compressor of the ammonia plant at the Misir site, which as high pressure and low pressure stages, had a thrust bearing failure at the HP stage due to control instrumentation failure. They reviewed the incident and the investigation analysis.

Fatima Fertilizer Company, Pakistan, reported on reaction loss in an ammonia synthesis converter followed by a fire incident. Reaction loss occurred during emergency handling after tripping of the urea plant which directly impacts the ammonia recovery/refrigeration circuit loads. As a result of rapid pressure increase and temperature decrease, synthesis gas leakage occurred from the ammonia converter outlet flange which resulted in a fire.

Koch Fertilizer and Clariant described how they worked together to avoid significant loss of conversion in the ammonia synthesis converters at the Koch Fertilizer Dodge City ammonia plant after it was found that the ammonia synthesis converters had been exposed to water and water vapour following an outage in 2015. They discussed the troubleshooting that was completed, safety precautions taken to ensure the ammonia synthesis converters were started back up without incident, actions taken to re-reduce the catalyst and lessons learned.

Yara Sluiskil, The Netherlands, shared the problem they experienced after a new duplex syngas loop cooler was installed. Shortly after the start-up of the plant, a leak into the canal water system was detected. Upon further investigation, severe cracking was discovered in the tube to tube sheet welds only two weeks after the new duplex heat exchanger came into service. The cause of the leakages was a combination of brittle welds due to wrong welding parameters and an insufficient hydraulic expansion of the tubes into the tube sheet.

Pardis Petrochemical Company reported on an ammonia plant compressor room fire which required reconstruction costs amounting to more than \$2 million and a shutdown of 60 days. The fire was caused by the disconnection of a ½ inch instrumental tube which was connected to the pressure differential transmitter and was installed between the inlet and outlet of the fourth stage in the synthesis compressor.

The disconnection caused leakage of high pressure gas which created a jet fire with a flame length of approximately 10 m.

Yara International Brussels and Stamicarbon discussed case histories and described possible failure modes for leakages in aging urea gas lines. The failure mode in all cases were similar but not fully understood. They can be classified as a kind of stress corrosion cracking phenomenon. Based on these experiences they recommend that during turnarounds, spot thickness measurements alone are insufficient, visual inspection should be carried out and if that is not possible preventive replacement of piping must be performed after 30 years of operation. Condensation of the process gas should be avoided as much as possible inside the pipes. Installation of proper insulation and tracing is prerequisite. Care must be taken to use the proper LP steam pressure to heat the pipes above the dew point of the process gas. Finally, gas pipe in the urea plant must have an appropriate review during the design phase.

OCI Nitrogen reported on ammonia tank inspection findings and follow-up tank modifications at two 1967 vintage ammonia tanks, located in Rotterdam. Completion of all modifications to the ammonia tanks were completed in seven months and the tanks are now equipped with significantly improved levels of safety.

## Other topics

Several other topics featured in the symposium programme including:

- Field experience from fibre optic ammonia and LNG leak detection system installations (SMARTEC and Rocrest)
- Topsoe Furnace Manager technology benefits for ammonia producers (Haldor Topsoe);
- Successful project execution and commissioning of the largest KRES ammonia plant (PCS Nitrogen, KBR, Clariant)
- Construction and commissioning of Kaltim-5 2,500 t/d, world's largest Ammonia Purifier™ plant (PT Pupik Kaltim, Kellogg Brown & Root);
- Ammonia distribution and handling improvements at Orica Australia;
- 4,700 t/d single train ammonia plant based on proven technology (thyssenkrupp Industrial Solutions)
- Development and commercial success of online SCR catalyst cleaning (Air Products, Cetek)

# New advances in platinum gauze systems

New generation gauze systems are achieving significant reductions in precious metal losses compared to conventional gauze layouts and can operate for longer campaign runs. Hindustan Platinum, SAFINA, Johnson Matthey and Umicore describe the benefits of their latest catalyst gauze systems for nitric acid plants.

Commercialised in 1910, the Ostwald process for nitric acid production has been constantly optimised. Plant designs have been reviewed in order to achieve higher product throughput and better performance. The platinum catalysts, responsible for the selective oxidation of ammonia to nitric oxide have also been subject to several innovations: the introduction of getter gauzes helped to dramatically reduce platinum losses during operation. Another prominent innovation was the transition from woven gauzes to knitted gauzes, which allowed the installed weight of precious metals to be decreased and reduced losses without sacrificing overall performance. More recent developments have focussed on environmental aspects of the process such as lowering  $N_2O$  emissions.

The need for new developments and technological progress related to the platinum catalysts continues since their performance impacts significantly on the production costs for nitric acid. In the following sections suppliers of catalyst gauze systems report on their latest developments.

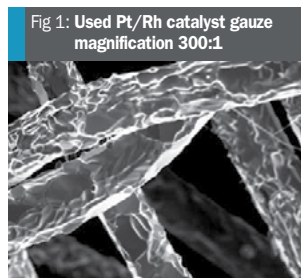

Fig 1: Used Pt/Rh catalyst gauze magnification 300:1

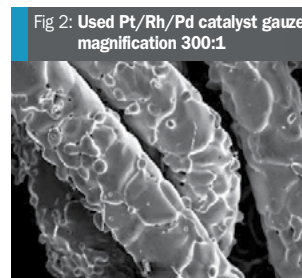

Fig 2: Used Pt/Rh/Pd catalyst gauze magnification 300:1

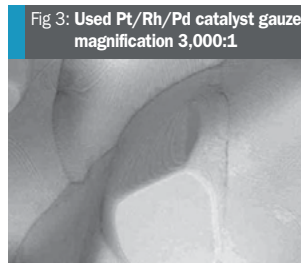

Fig 3: Used Pt/Rh/Pd catalyst gauze magnification 3,000:1

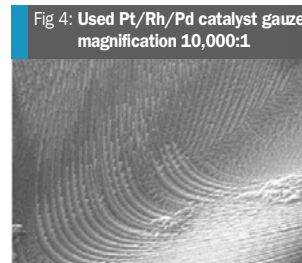

Fig 4: Used Pt/Rh/Pd catalyst gauze magnification 10,000:1

PHOTOS: HINDUSTAN PLATINUM

## Hindustan Platinum gauze systems

Hindustan Platinum has more than 50 years of experience in the field of precious metal products and services. The Nitro Technologies Division at Hindustan Platinum provides catalyst and getter applications in the ammonia oxidation process and has gained comprehensive professional knowledge and expertise in precious metal processing, catalyst technology as well as process modelling and simulation that enable a holistic optimisation of the gauze catalyst adjusted to the individual ammonia oxidation process.

Despite much progress in catalyst technology, a major problem with the use of platinum catalysts for ammonia oxidation remains the loss of platinum from the gauzes. During the ammonia oxidation process the gauzes undergo deep structural rearrangement of surface layers leading to platinum loss and decrease of catalytic activity. Consequently the catalyst determines the process yield and the extent of the platinum loss and thus the economical reasonable campaign length.

The common alloying elements platinum, rhodium and palladium show a completely different behaviour towards oxygen under the high-temperature conditions of the ammonia oxidation process. When platinum is heated in air up to a temperature at which it glows with a dull-red colour, a film of solid oxide is formed on its surface. As the temperature further rises, the oxide experiences a phase change from PtO solid-phase directly to PtO gas-phase that escapes from the vicinity of the metal surface. Rhodium oxidises at high temperatures in air to form

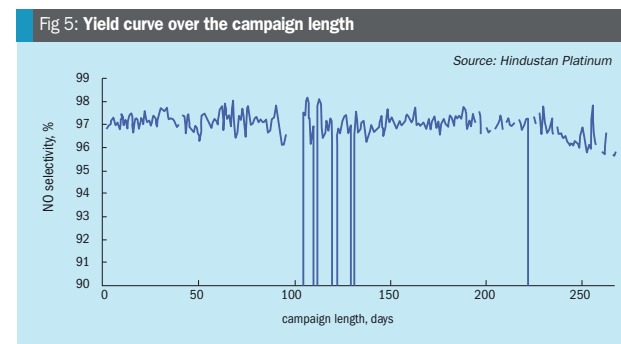

$Rh_2O_3$  which remains as the stable phase; while in palladium, the oxygen is present in a solid solution not as palladium oxide.

The volatility of platinum is appreciably reduced by alloying it with rhodium. Here, the stability of platinum towards the formation of its volatile oxide increases with rising rhodium content in the alloy; whereas due to the formation of inactive  $Rh_2O_3$  on the catalyst surface, the catalytic activity decreases to the same extent so that the selection of the individually optimum rhodium content in the platinum-rhodium alloy represents an economical balance of platinum loss and process yield.

A further reduction of platinum losses is achieved by the addition of palladium to the platinum-rhodium alloy. Since palladium does not form a solid palladium oxide on its surface and due to its high affinity to oxygen, palladium has the ability to reduce the volatile platinum oxide from

the process gas to platinum and to alloy it into a solid palladium-platinum solution. Compared to platinum, palladium shows a comparable NO-selectivity at somewhat higher temperatures, making it advantageous to apply palladium-rich alloys in the high-temperature zone of the catalyst.

The effectiveness of such Pt/Rh/Pd ternary alloys becomes apparent from the surface morphology of the spent catalyst. In contrast to the highly faceted surface of the Pt/Rh binary alloy, which can be seen in Fig. 1, the surface of the used catalyst gauze of a Pt/Rh/Pd ternary alloy appears significantly smoother due to the alloying of the recaptured platinum, shown in Figs 2-4. In the 10,000-fold magnification the step-like dislocations become visible forming the active centres of the catalyst. Fig. 4 demonstrates that the recovered platinum assembles a new high-performance surface morphology on the wire surface.

Fig 6: Simulated correlation of N/O surface coverage and relative  $N_2/NO$  formation rate

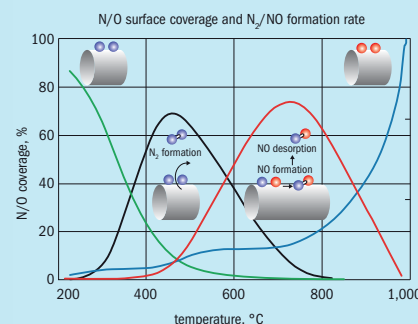

Source: Hindustan Platinum

Fig 7: Simulated correlation of  $N_2/N_2O/NO$  selectivity and gauze temperature

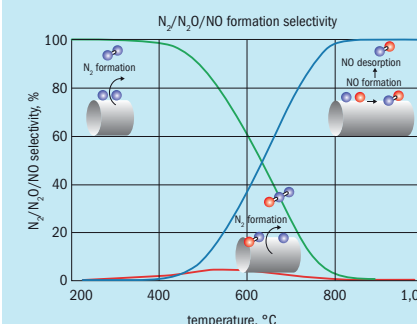

Source: Hindustan Platinum

Table 1: Industrial example of catalyst pack performance (Uhde medium pressure ammonia oxidation process)

Catalyst pack alloy	Pt/ Rh – binary alloy			Pt/ Rh/ Pd – ternary alloy		
Campaign length, days	267			274		
HNO <sub>3</sub> production, t (100%)	262.585			270.913		
Yield, %	96.5 - 97.5			96.5 - 97.5		
	Platinum	Rhodium	Palladium	Platinum	Rhodium	Palladium
PGM loss from catalyst, g	46.420	1.395	-	38.261	1.237	1.648
PGM loss from catalyst, mg/t	176.8	5.3	-	141.2	4.6	6.1
PGM loss incl. recovery, mg/t	37	3	51	20	3	55

Source: Hindustan Platinum



There have been proven configurations, especially good gauze pack configurations in which catalyst gauzes of individual platinum-rhodium alloys are found on the gas inlet side to provide better ignitability of the incoming ammonia-air mixture and thus to guarantee highest NO selectivity. The palladium rich gauzes on the gas exit side of the gauze package are graduated in their palladium content to ensure maximum recovery of the platinum entrained in the process gas stream (Table 1).

The use of such individually configured catalyst gauze packs prolongs the service life of the catalyst gauzes, saves platinum metal and reduces the costs of nitric acid production.

Fig. 5 illustrates the corresponding yield curve over the campaign length. The catalyst reached its maximum efficiency of more than 97% after a relatively short operating time, and shows a stable process performance even with frequent starts and stops of the reactor.

Another effect of using palladium in the catalyst alloy is the reduction of  $N_2O$  emissions from the ammonia oxidation process. In contrast to platinum and rhodium, which form on their surface solid oxides preventing the adsorption of  $N_2O$ , palladium has the ability to adsorb  $N_2O$  on its surface and to convert it with  $NH_3$  from the process gas catalytically to  $N_2$ . Due to the higher volatility of PdO compared to PtO, platinum increasingly accumulates on the catalyst surface over time, whereby the ability for  $N_2O$  reduction decreases with the campaign length.

Optimised adaptation of the individual catalyst gauzes in the catalyst pack requires a sound understanding of the particular operation mode and the underlying process mechanism. Therefore, Hindustan Platinum has developed a comprehensive mechanistic model for product selectivity based on mass-transfer-limited combustion and detailed micro kinetic description of the surface  $N_2$ -, NO- and  $N_2O$ -forming steps. Figs 6 and 7 show the simulated correlation of the  $N_2O$  surface coverage and  $N_2/NO$  formation rates on the catalyst surface and the resulting  $N_2/N_2O/NO$  selectivity, using an example of a medium-pressure process.

Combined with the process simulation explicit expressions are obtained which incorporate all the process and gauze parameters in the system for the individual products and thus the selectivity of the process. This allows the adjustment of the catalyst to its ambient process conditions and enables the process performance to be optimised in its entirety.



SAFINA catalyst gauze knitting process.

PHOTO: SAFINA

### SAFINA gauze system technology

SAFINA, through a worldwide partnership with its sister company, Ekaterinburg Precious Metals Processing Plant (EZOCM), presented its latest advances in catalyst and getter gauze at the ANNA Conference in 2015. EZOCM, based in Ekaterinburg, Russia, has a 70 year history of manufacturing gauze for nitric acid plants in Eastern Europe. The new relationship with SAFINA, with resources to provide post-campaign chemical analysis and refining facilities in North America and Europe, is now enabling expansion into North America, Europe and Asia.

The SAFINA gauze systems offer unique features quite different from other suppliers. For example, most gauze systems utilise only one alloy (such as 90% platinum-10% rhodium) for the catalyst pack. The SAFINA gauze system uses a stacked design with two or three alloys designed according to the specific requirements of each nitric acid process. The first sheets use a standard platinum-rhodium alloy, and secondary gauze sheets often include palladium content that provides multiple benefits. First, the palladium increases the heat resistance to slow degradation and metal losses from the gauze surface. Second, the palladium acts to catch released platinum from the top gauze sheets to provide additional reactive sites on lower sheets. Finally, the palladium serves to provide more surface area that can retain the platinum to provide further surface reactions and contribute to reduced metal losses.

For applications where it is desirable to reach maximum efficiency more rapidly, SAFINA provides a special treatment of the top layers of platinum alloy gauze. The proprietary electro-chemical activation process (ECA) applies a thin layer of platinum to the wire surface. This reactive layer of dispersed platinum elevates the gauze surface area tenfold to ensure better gas contact. The more reactive surfaces reduce ignition time to increase productivity.

Another method to reduce precious metal losses is through the use of a special getter gauze with better collection and retention efficiency. A key feature of the SAFINA/EZOCM getter gauze is the use of a palladium-tungsten alloy rather than the palladium-nickel alloy commonly used

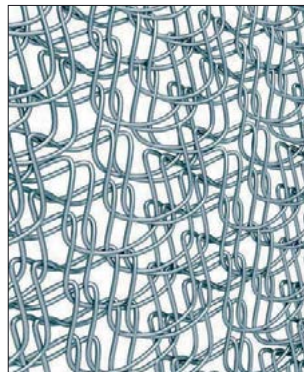

SAFINA knitted catalyst gauze structure.

PHOTO: SAFINA

# SECONDARY CATALYSTS



High level  $N_2O$  reduction

Customized PGM & Non-PGM solutions

Technical on-site support

Outstanding innovations, technical and commercial competence, continuous improvement and use of the most efficient production techniques make Heraeus Catalytic Technology the worldwide technology and cost leader in this business area.

FTC SYSTEMS • SECONDARY CATALYSTS • CORRUGATED GAUZES

Germany  
**Heraeus Deutschland GmbH & Co. KG**  
 GBU Heraeus Chemicals  
 Product Group Catalytic Technology  
 Heraeusstr. 12 - 14  
 63450 Hanau, Germany  
 Phone +49 6181.35-5104  
 Fax +49 6181.35-3533  
 catalyticsystems@heraeus.com  
 www.heraeus.com

P. R. China  
**Heraeus Materials Technology Shanghai, Ltd.**  
 1 Guang Zhong Road  
 Zhuangqiao Town Minhang District  
 Shanghai 201108  
 Phone +86 (21) 3357-5512  
 Fax +86 (21) 3357-5699  
 hmsts@heraeus.com  
 www.heraeus-hmsts.com

India  
**Ravindra Heraeus Pvt., Ltd.**  
 A-195/196, 'F' Road  
 Mewar Industrial Area, Madri  
 Udaipur - 313 001  
 Phone +91 (294) 2 49 00 29,  
 2 49 20 27  
 Fax +91 (294) 2 49 18 25,  
 2 49 21 77  
 info@ravindraheraeus.com  
 www.ravindraheraeus.com

USA  
**Heraeus Materials Technology North America LLC**  
 280 North Roosevelt Avenue  
 85226 Chandler, AZ  
 Cell +1 (727) 480-1437  
 Fax +1 (727) 442-6523  
 info.hmtna@heraeus.com  
 www.heraeus-hmtna.com

CONTENTS

What's in issue 344

COVER FEATURE 1

Advances in platinum gauzes

COVER FEATURE 2

Urea markets

COVER FEATURE 3

Olefins drive methanol expansions

COVER FEATURE 4

Integration of ammonia/urea plants

NITROGEN+SYNGAS  
**ISSUE 344**  
 NOVEMBER-DECEMBER 2016

**BCInsight**

Southbank House, Black Prince Road  
 London SE1 7SJ, England  
 Tel: +44 (0)20 7793 2567  
 Fax: +44 (0)20 7793 2577  
 Web: www.bcinsight.com  
 www.bcinsightsearch.com

Table 2: Comparison of tensile strength: 0.5mm wire diameter

Test sample	Wire treatment	PdW5%	PdNi5%
		Tensile strength, N/mm <sup>2</sup>	Tensile strength, N/mm <sup>2</sup>
1	Strain 75%, test at 20°C	700 - 715	610 - 620
2	Annealing 850°C for 30 minutes, test at 20°C	370 - 390	310 - 325
3	Annealing 850°C for 30 minutes, test at 900°C	90 - 100	75 - 85

Source: SAFINA

in North America and Europe. EZOCM is the only gauze manufacturer using a palladium-tungsten (PdW) alloy for the getter/catchment gauze. This alloy has been in use for over ten years, and independent testing by the State Institute for Nitric Acid quantified the benefits of this alloy in high pressure reactors.

The robust palladium-tungsten getter gauze acts to catch more platinum and provide additional reactive surface area in the later stages of the campaign period. Data shows that the PdW alloy has increased mechanical durability and heat resistance due to the higher melting temperature of this alloy. Specifically, PdW5% has a melting point of 1,550°C compared to 1,410°C for PdNi5%. Test data also show higher tensile strength at both room and operating temperature (see Table 2). This feature makes the getter gauze more durable with better resistance to breakdown during long campaign lengths. Therefore, the SAFINA getter gauze is better able to support longer campaigns at higher temperatures with no degradation of collection efficiency.

For one recent project, SAFINA was able to increase the campaign period by 23% to just over six months, while simultaneously reducing platinum content by 11% and platinum-rhodium losses during ignition by 10%. Thus, the SAFINA gauze system reduces working capital, increases the time between reactor shutdowns and retains more precious metal within the gauze sheets to reduce costly recovery projects.

SAFINA experience with a variety of alloys previously not available in Europe and North America gives new options to customers looking to improve their plant productivity. Each variable (alloy sequencing, wire diameter, coating, number of sheets, etc.) can be adjusted to reduce working capital, increase campaign length, improve conversion efficiency and/or reduce precious metal losses.



Johnson Matthey knitted gauze.

### Johnson Matthey gauze technology

Johnson Matthey has come a long way since supplying its first 4" by 6" platinum woven gauze pack for the UK Munitions Invention Department back in October 1916. Ever since, Johnson Matthey has worked closely with producers to overcome the numerous challenges nitric acid plants face. The latest developments of this accumulated experience in gauze technology are the family of Eco-Cat™ systems, which combine platinum group metal with complex ternary alloys and knit structures. It uses palladium in a controlled manner to replace some of the platinum in the gauze, exploiting its metal recovery properties to catch lost platinum without compromising the ammonia conversion. This gives a sustainable and efficient system for nitric acid production, with increased performance compared to standard catalyst packs, including (subject plant operating parameters and existing catalyst gauze system):

- reduction in installed platinum group metal (pgm) gauze weight by 40-50%;
- reduction in installed platinum weight by 30-40%;
- extended campaign lengths by 50-100% maintenance or improvement of conversion efficiency;
- reduced value of metal losses by up to 30-50%;
- reduced N<sub>2</sub>O emissions.

These benefits are exemplified in Table 3, demonstrating the increase in campaign length and nitric acid production when standard gauze packs were replaced by Eco-Cat™ technology in a medium pressure plant.

### Gauze development

Johnson Matthey recently developed a customised Eco-Cat™ system solution for one producer that wanted to reduce the installed metal content of the gauze packs and reduce metal losses while increasing

Table 3: Campaign results using a standard gauze pack and two iterations of Eco-Cat™ technology

	Standard pack	Eco-Cat™ system (campaign 1)	Eco-Cat™ system (campaign 2)
Campaign length, days	~100	~175	~210
100% HNO <sub>3</sub> produced, '000 tonnes	~85	~135	~160
Total mass gauze, kg platinum	~50	~40	~40
Total mass gauze, kg rhodium	~3	~2	~2

Source: Johnson Matthey

Fig 8: Platinum group metal (pgm) content and value in iterations of Eco-Cat™ packs

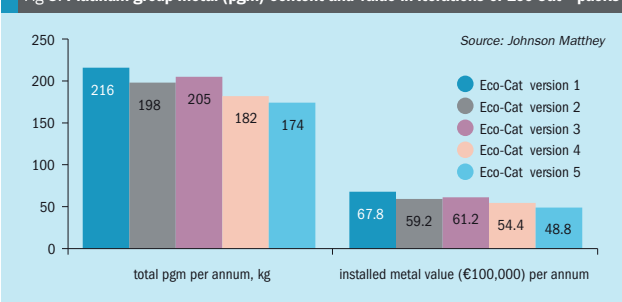

Fig 9: Platinum group metal (pgm) losses in iterations of Eco-Cat™ packs

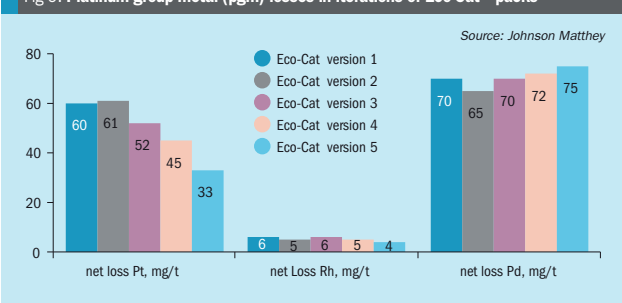
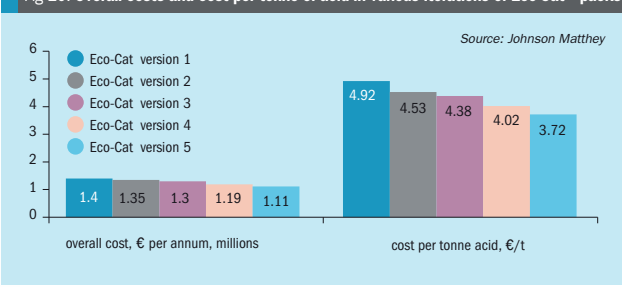

Fig 10: Overall costs and cost per tonne of acid in various iterations of Eco-Cat™ packs



average conversion efficiency. To tailor the Eco-Cat™ system to plant conditions, iterative changes were carried out, driven by analytical data from analysis of the gauze. Detailed examination of gauze samples showed an operational issue related to the plant design, impacting the gas flow characteristics across the catalyst and therefore affecting the conversion efficiency and metal recovery of the overall system. Additionally, the relative gas flow variation in the burner was measured and was found to be higher than certain areas, causing the gauze to be depleted faster in these regions. The variation in gas-flow not only resulted in more platinum movement but also a lower ammonia conversion rate.

Using the available range of Johnson Matthey gauze structures and mechanical properties, an inventive solution was used to address the regional flow issues in the burner while also focussing on the initial requirements (Fig. 8). The implemented changes improved the conversion efficiency. The catalyst design was further improved using analytical data from previous campaigns, data from the producer and acknowledging the impact of seasonal variations. Through tailored wire diameters and knit structures, the reaction zone was optimised and the installed metal content was reduced (Fig. 9).

The development of the tailored catalyst system contributed to a substantial reduction of the costs per tonne of nitric acid (Fig. 10), benefiting the producer and meeting their requirements.

### Faster light off

Research has been carried out to investigate how the time required to reach peak conversion efficiency can be reduced – a key goal for most nitric acid producers. Laboratory analysis highlighted that platinum is volatilised during normal operation and forms cauliflower-like structures on wires, increasing the overall catalytic surface area. Johnson Matthey's ACT™ coatings, which use a thinly sprayed layer of molten platinum on the surface of selected layers in the gauze packs, has shown improved 'start up' properties of the gauzes, giving a faster light off.

### Abatement containment design

Johnson Matthey provides engineering solutions for installing nitrous oxide abatement catalysts; a well-oxidised containment system is essential to evenly

## CONTENTS

What's in issue 344

## COVER FEATURE 1

Advances in platinum gauzes

## COVER FEATURE 2

Urea markets

## COVER FEATURE 3

Olefins drive methanol expansions

## COVER FEATURE 4

Integration of ammonia/urea plants

NITROGEN+SYNGAS  
**ISSUE 344**  
NOVEMBER-DECEMBER 2016

**BCInsight**

Southbank House, Black Prince Road  
London SE1 7SJ, England  
Tel: +44 (0)20 7793 2567  
Fax: +44 (0)20 7793 2577  
Web: www.bcinsight.com  
www.bcinsightsearch.com



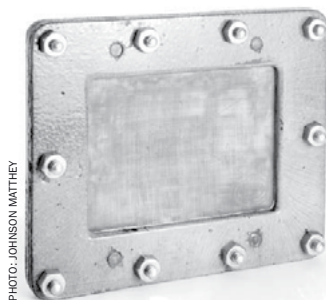

PHOTO: JOHNSON MATTHEY

Johnson Matthey's first woven gauze.

distribute the gases throughout the catalyst bed, therefore ensuring good performance. Due to the thermal cycling of the system, the design must be robust with the mechanical integrity to cope with a large number of campaigns.

Burner and gauze damage was witnessed at a plant, caused by a large pressure drop across the abatement catalyst. The pressure drop caused the base of the existing basket to warp under the strain, leading to irregular gas distribution. As a result, the plant performance was decreasing. Initially the customer wanted its current secondary abatement catalyst replaced with Yara pellets, which had a lower pressure drop, however further investigation revealed the extent of the damage; it required a complete redesign.

The installation of a new basket design noticeably improved the abatement performance and the basket operated with a reduced pressure drop. This benefited the overall conversion efficiency by reducing the preferential flow over the burner and also resulted in reduced metal losses.

#### Gauze modelling

Johnson Matthey has a long history of supplying catalyst, catchment and abatement solutions to the nitric acid industry and recently celebrated 100 years since supplying the first UK gauze (pictured above). Using this extensive experience, Johnson Matthey is able to develop complex models using the fundamental chemical and physical properties of the reaction system alongside proprietary data.

In depth knowledge and modelling of the burner gives more certainty about the selectivity of ammonia conversion to nitric acid over the burner, detailing the extent

and type of reaction. Known process conditions along with knowledge of gauze design are used for complex modelling of the burner, helping to identify where efficiency losses may occur. Once root causes have been identified, different sensitivities can be investigated to optimise the process and maximise the plant's conversion efficiency.

To refine and improve the accuracy and validity of the process model compared to one that is theoretically derived, Johnson Matthey has developed a dynamic kinetic model of the burner. Knowledge from spent gauze analysis, test rig data and historic plant data give an understanding of changes to gauzes over time and how this impacts the overall conversion efficiency.

This detailed kinetic model can predict the optimal Johnson Matthey knit structures and alloy compositions for a campaign. For example, the way catalyst gauzes restructure is an essential component of the kinetic model, as it is closely linked to the performance of the gauze as a catalyst; an increase in active surface area can improve the conversion efficiency of the gauze. The model has the scope to relate individual plant conditions to metal losses, which can reduce costs for producers and improve the conversion efficiency of the burner. The modelling findings can then be related to experimental observations found from analysing the gauze.

Historically, producers have found it difficult to directly measure conversion efficiency and selectivity; it is challenging to obtain a representative gas sample over gauzes due to high gas temperatures and testing considerations of the sampling point. This robust gauze model is therefore critical in optimising the overall plant operation.

#### Umicore catalyst systems

Umicore officially launched MPAC (multi-combination gauze pack) with its multitude of features and possibilities in gauze designs for the nitric acid industry back in December 2014. At that time Umicore committed to a constant improvement philosophy, reinforcing its R&D and product development capabilities and launched several long term research programmes with the aim to improve catalyst selectivity and lower precious metal losses.

Now after more than one year of MPAC in operation out in the field, MPAC has successfully proved its performance in several low pressure, medium pressure and high pressure nitric acid plants.

MPAC technology is based on Umicore's well known and established catalyst systems MKS and MKS*precise* and with its newly added features it allows a much higher degree of tailoring in order to meet the requirements of each plant in the best possible way. In contrast to MKS

and thickness of the wires have a major influence on the performance of the catalyst gauzes. MPAC systems make us of newly designed alloys that are able to maintain an excellent level of catalytic activity and at the same time significantly reduce  $N_2O$  emissions and precious metal losses. Due to a much wider range of wire diameters catalyst packages can be designed with the optimal weight for the desired campaign length.

#### Production technology and gauze structures

Umicore's flat-bed knitting technology has taken its gauze designs one step further by moving it into the third dimension. All gauzes, single or multilayer, are not just a two dimensional arrangement of wires in a flat gauze, but real three dimensional structures due to unique knitting patterns with dedicated amounts of wires being oriented out of the layer-plane. Umicore has further optimised its production technology and revamped its equipment in order to further increase flexibility and maximise technical possibilities regarding degrees of freedom. For each single gauze the knitting patterns and features like density, porosity and final gauge weight can be tailored to requirements.

#### Alloys and wires

Besides the gauze structure the chemical composition as well as the composition

and thickness of the wires have a major influence on the performance of the catalyst gauzes. MPAC systems make us of newly designed alloys that are able to maintain an excellent level of catalytic activity and at the same time significantly reduce  $N_2O$  emissions and precious metal losses. Due to a much wider range of wire diameters catalyst packages can be designed with the optimal weight for the desired campaign length.

#### R&D and product development

Umicore's R&D and product development team is constantly working on activities and research programmes in order to improve the performance of MPAC systems. Simulation (see Fig. 11) and experimental methods are used to generate models that are proved and tested under realistic conditions in real reactors.

Recently it was shown that flow simulations including detailed surface chemistry provide an improved understanding of the interaction of flow, diffusion and surface reaction. Umicore's newly developed simulation tools combine CFD modelling (flow) with the rate mapping approach

(chemistry) to successfully simulate ammonia oxidation on complex gauze geometries under industrial conditions. This method is an extremely helpful tool in order to develop new gauze layouts with increased performance.

All new developments are tested first in the laboratory and if performance is confirmed the new gauze systems are extensively tested in pilot scale reactors which allow operation of the gauzes under realistic industrial process conditions.

#### Data analysis

Umicore possesses large amounts of valuable production data, accumulated over many years of experience in the nitric acid industry. To better handle this data and extract valuable and trustworthy information from it, Umicore uses a software tool based on multivariate data analytics, to carry out performance benchmarks and compare the results of multiple campaigns. The results serve as an ideal basis for the design parameters for the catalyst and help the customer to identify the optimal operating conditions. ■

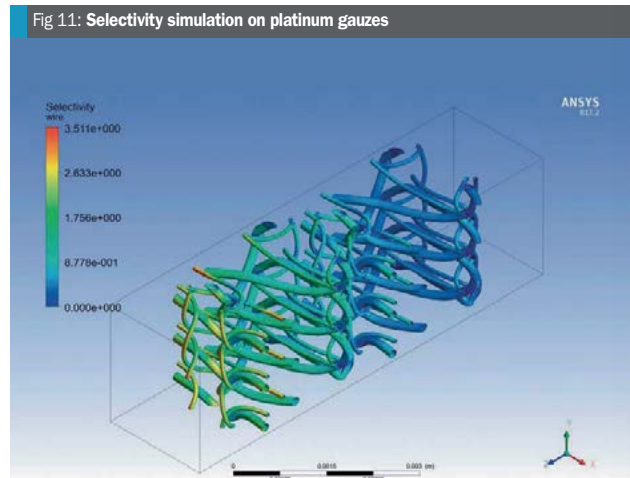

Fig 11: Selectivity simulation on platinum gauzes

Source: Umicore



Schoeller-Bleckmann Nitec, Hauptstrasse 2, A-2630 Ternitz, P: +43/2630/319-0, F: +43/2630/319-19, E: sbn@christof-group.com, I: www.christof-group.com



## How to save time & money

Even the best equipment is subject to wear and tear, and that means expensive plant turnarounds. As a leading high-pressure vessel manufacturer in the nitrogen sector, we can save you time and money by performing the maintenance and in situ repair of your heat exchangers and reactors in the shortest possible time. And we can provide replacements, seeing to everything from design to installation.

We have all the know-how to work with all the materials involved – and a strong international track record of successful reference projects. Our highly skilled task force have already completed a large number of in situ works abroad.

So why not ask our specialists to advise you on your next in situ project?



#### CONTENTS

What's in issue 344

#### COVER FEATURE 1

Advances in platinum gauzes

#### COVER FEATURE 2

Urea markets

#### COVER FEATURE 3

Olefins drive methanol expansions

#### COVER FEATURE 4

Integration of ammonia/urea plants

NITROGEN+SYNGAS  
ISSUE 344  
NOVEMBER-DECEMBER 2016

BCInsight

Southbank House, Black Prince Road  
London SE1 7SJ, England

Tel: +44 (0)20 7793 2567

Fax: +44 (0)20 7793 2577

Web: www.bcinsight.com  
www.bcinsightsearch.com

# Improved economics of ammonia-urea fertilizer plants

Several process schemes for the integration of the ammonia and urea plants in a fertilizer complex have been suggested in the past as a way to reduce both operating and investment costs but, so far, none of them has been realised. A new process scheme from thyssenkrupp Industrial Solutions (tkIS) aims to realise most of the cost savings promised by process integration but to avoid the critical issues associated with fully integrated concepts. **J. Johanning** and **Y. Makhnya** of tkIS describe the new concept and present the savings in energy consumption, waste heat to cooling water system and capital cost for a typical fertiliser complex.

After a relatively slow start urea has become one of the most important commodities during the last three decades. Annual world consumption today is in excess of 180 million t/a with a significant yearly growth rate in the order of 3-4%. Urea has established itself as the number one nitrogen fertilizer. About 85-90% of the entire world urea production is directly used as fertilizer, either granulated, prilled or blended into UAN solution. However, there are also several important non-fertilizer uses, e.g. in the production of plastics such as melamine or urea formaldehyde, pharmaceuticals, animal feed additive or, relatively recently, as an ammonia source in NOx emission reduction systems for diesel engine powered vehicles.

With an average energy consumption of about 5.4 Gcal/tonne of urea, global urea production continuously absorbs about 140,000 MW of thermal power. This is a significant portion of the entire energy consumption of mankind and represents a value in the order of \$4.0 billion per year in feedstock costs. A world size ammonia-urea fertilizer complex nowadays is associated with a capital investment of more than \$1.0 billion. Hence, a lot of effort has been spent and is still being invested with the aim to reduce both the specific energy consumption as well as capital costs of urea

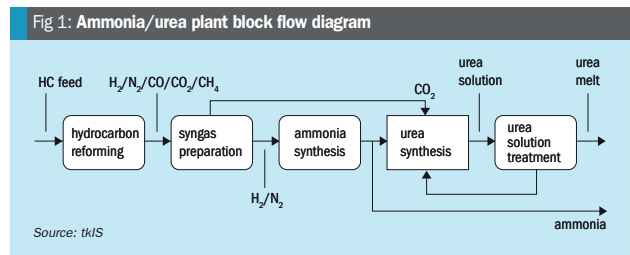

production. Closer integration of plants is often a route leading to savings and has attracted research in the case of ammonia and urea plants as well. However, whereas the steam systems of the ammonia and urea plants as well as the off-sites and utilities are very well integrated in modern ammonia/urea fertilizer complexes the process plants themselves still remain fairly independent of each other.

The concept presented here appears to have the potential to achieve significant reductions in both specific energy consumption as well as capital investment and thus generally improve the economics of urea production for any given set of plant conditions. Further advantages of the concept are that start-up and shutdown of the entire fertilizer complex will not become significantly more complicated and most

of the operational flexibility of conventional urea plants is retained.

## State-of-the-art urea synthesis

Ammonia plants generate large quantities of carbon monoxide and carbon dioxide when the synthesis gas production is based on a hydrocarbon feedstock. Hence, locating urea plants in close vicinity to ammonia plants is the most economical solution and has become the industrial standard.

Fig. 1 presents a basic block flow diagram of a typical ammonia/urea fertilizer plant. The hydrocarbon (HC) feed, e.g. natural gas, is mixed with steam and reformed to generate a raw synthesis gas composed of hydrogen, nitrogen, carbon monoxide, carbon dioxide, methane and water. In

**Fig 2: Ammonia and CO<sub>2</sub> pressure variations in current ammonia/urea production plants**

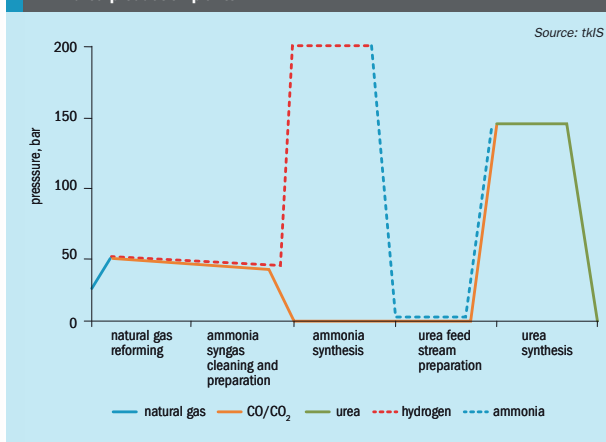

the syngas preparation section the carbon monoxide is converted to carbon dioxide, which is subsequently removed from the syngas, usually via scrubbing with a selective solvent.

After final purification the ammonia syngas, now mainly consisting of hydrogen and nitrogen in the correct proportion, enters the ammonia synthesis where it is converted into ammonia. Part of the ammonia is sent directly to the urea synthesis. The split between the ammonia fraction immediately used for urea production and the other part, which is usually sold independently, depends on the amount of carbon dioxide provided by the synthesis gas generation section of the ammonia plant. For newly built plants full processing of the produced ammonia into urea as well as any ratio between ammonia and urea is possible with relatively little additional investment cost. Finally, the urea solution generated by the urea synthesis is purified, concentrated and solidified, e.g. granulated.

## Potential for process improvements

To identify options which may have the potential to improve the economics of a chemical process it is usually helpful to examine the temperature and pressure variations along the main process flow path. Such variations are in principle associated with efficiency losses and significant equipment costs. Particularly important in this respect are

pressure changes in the gaseous phase, given the limited efficiencies and comparatively high costs of turbomachines in general.

Hence, significant savings in investment, and often in operating costs as well, can usually be realised if a large temperature or pressure change can be avoided or at least significantly reduced. Potential savings may also be available if a compression step can be carried out in the liquid state.

In ammonia/urea plants both ammonia and carbon dioxide are subjected to fairly large pressure variations upstream of the urea synthesis as illustrated in Fig. 2. The conventional urea process requires these variations to separate ammonia as well as carbon dioxide from the process streams and to achieve the required purities for urea synthesis. Since carbon dioxide is usually delivered in gaseous state by the CO<sub>2</sub> removal unit practically at atmospheric pressure, its compression to urea synthesis pressure is energy intensive and requires a sophisticated compressor.

One option to eliminate the recompression step of the carbon dioxide from atmospheric pressure is to remove the carbon dioxide from the ammonia synthesis gas via scrubbing with ammonia or ammonia water solutions, raise the pressure of the resulting carbamate solution to urea synthesis pressure by a high pressure pump and send it to the urea synthesis. This basic concept is incorporated into most integrated process schemes which have been proposed in the past. Since the CO<sub>2</sub>

removal section as well as the entire CO<sub>2</sub> compressor would be eliminated from the plant flowsheet very significant reductions in capital investment can be assumed.

However, major drawbacks of these schemes are the introduction of large quantities of water into the urea synthesis and unfavourable energy utilisation conditions. Another disadvantage of these schemes compared to the conventional plant concept is that the ammonia plant cannot be run stand-alone with the urea plant in shutdown mode. Also, start-up of such fully integrated plants is likely to be significantly more complicated.

## thyssenkrupp Industrial Solutions concept

The process technologies business unit of tkIS (formerly operating under the name ThyssenKrupp Uhde GmbH) thoroughly investigated other alternatives to reduce the energy consumption and capital cost of ammonia/urea fertilizer plants which do not affect the urea synthesis itself. One result of these investigations is presented here in detail.

An alternative to the fully integrated process schemes is to reclaim the carbon dioxide from the carbamate solution generated in the CO<sub>2</sub> wash with ammonia at urea synthesis pressure. Thus, the concept basically replaces mechanical power for compression by heat for the desorption. Given the fairly high pressure level of the urea synthesis the carbon dioxide can only be reclaimed from the solution at significantly higher temperatures compared to the CO<sub>2</sub> removal section in a conventional plant. To make this process concept feasible, a solvent must be used which is stable at the required higher desorption temperatures such as e.g. 190-220°C. Since ammonia is stable at such temperatures and present in most units downstream of the CO<sub>2</sub> removal system it is the natural choice as a solvent in this case even with its relatively high vapour pressure.

## Basic process concept

Fig. 3 illustrates the basic principle of the new process concept in comparison with the conventional process scheme. In conventional ammonia/urea production plants the carbon dioxide is usually removed from the ammonia synthesis gas via scrubbing with a selective solvent, usually aqueous solutions containing activated MDEA, potassium carbonate or polyethyleneglycol-



Fig 3: Comparison of conventional scheme and alternative thyssenkrupp Industrial Solutions concept

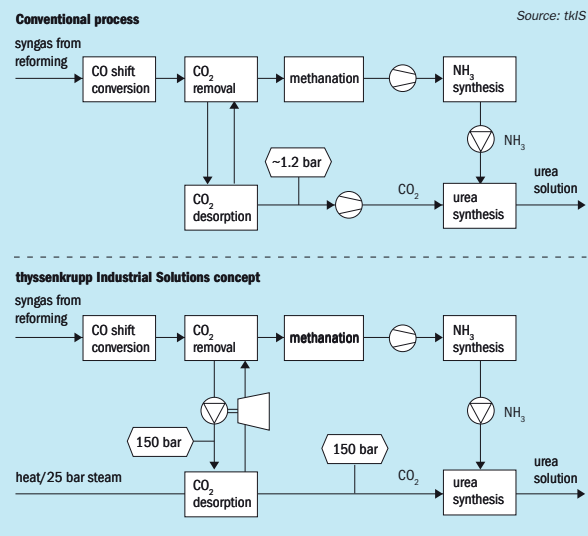

dimethylethers. The carbon dioxide is recovered from the solvent at near atmospheric pressure and needs to be recompressed to be fed to the urea synthesis.

The solution now proposed and filed for patent protection by thyssenkrupp Industrial Solutions removes the carbon dioxide from the synthesis gas via scrubbing with an ammonia/water solution. The pressure of the resulting CO<sub>2</sub>-rich solution is subsequently lifted to urea synthesis level by a high pressure pump. Recovery of the carbon dioxide is carried out at this pressure level, thus avoiding both the mechanical work associated with the recompression in the gas phase and the capital costs for the entire CO<sub>2</sub> compressor unit.

In essence, the mechanical recompression work in conventional plants is replaced by thermal energy in the new process concept. Obviously, extraction of the carbon dioxide at the higher pressure requires a significantly higher temperature level compared to the one present in the desorber columns of CO<sub>2</sub> removal systems based on organic solvents. Hence, due to the higher temperature more valuable thermal energy has to be provided to the desorption column in the new concept. However, this thermal energy can be taken directly from the plant's waste heat and does not have to be transformed first

into mechanical power as in the conventional plant to drive the CO<sub>2</sub> compressor.

Fig. 4 presents a flow diagram of the alternative CO<sub>2</sub> removal system based on ammonia/water solution and highlights some characteristic operating parameters. The diagram is supplemented with values from an example calculation. It should be noted that the values represent a particular case and can be adjusted by considerable margins to accommodate specific operating conditions.

The raw synthesis gas coming from the CO conversion section is cooled down and enters the absorber 1 at 40°C and a pressure of about 36 bar. Depending on site requirements and water content it can be cooled down further in chiller 11 prior to the CO<sub>2</sub> absorption step. The lean solution enters the column also with a temperature of 40°C. Absorption takes place in counter-current mode in the packed column, generating an enriched solution predominantly containing ammonium carbamate, ammonium bicarbonate and ammonium carbonate. The exact composition depends on the reaction conditions inside the column.

These reactions are exothermic, thus both liquid and gas phase should be cooled in order to keep the ammonia slip low. The liquid phase especially is rather

hot. Hence, it makes sense to re-integrate at least a part of the generated thermal energy into the process. The purified syngas still contains some ammonia and water which are separated from the syngas via cooler 12 and flash vessel 21. The purified syngas has a CO<sub>2</sub> content below 500 ppm. Furthermore it contains about 1.6 mol-% of ammonia and 0.18 mol-% water. These purity levels are expected to be acceptable for the methanation step as well as for the ammonia synthesis.

The liquid phase from flash vessel 21 is let down to about 2 bara and combined with the enriched solvent, which has been cooled down to 45°C in heat exchangers 13 and 14 and also let down to about 2 bara in hydro expander 2. The combined stream is flashed in flash vessel 22 in order to remove co-absorbed inerts such as hydrogen, nitrogen etc. The resulting purified solution is then compressed in high pressure pump 3 to about 150 bar and fed to desorber column 4. In heat exchangers 14 and 15 heat integration with the hot rich solution from the absorber and the hot condensate from the overhead product takes place. For further heat integration between preheated rich solution, desorber bottom product and hot overhead product in heat exchangers 16 and 17 the rich solution is split-up in two streams. The final feed temperature of about 195°C prior to entering the desorber column 4 is reached in steam heated heat exchanger 18.

The hot (200°C) CO<sub>2</sub>-enriched overhead product of desorber column 4 is too warm for direct entry into the stripper for the urea solution. It also contains significant amounts of ammonia and water which should be separated. Therefore, the hot overhead product is first cooled down to 110-120°C in heat exchanger 16 where it transfers valuable heat to the desorber feed stream and subsequently flashed in separator 23. The resulting gas phase represents nearly pure CO<sub>2</sub> of about 98 mol-% purity with water and ammonia concentrations below 1 mol-%.

The hot lean solution from the bottom of the desorber column 4 is cooled down further in cooler 19 after heat integration, transferred to the hydro turbine 5 and depressurised from 150 bar back to 36 bar. Finally, the regenerated cold lean solution re-enters the absorber column 1. Due to the fact that small amounts of ammonia and water continuously slip out of the wash cycle via the purified syngas, the purified CO<sub>2</sub> and the purge gas from flash vessel 22, the two small pumps 6 and 7 for

Fig 4: Flow diagram of the ammonia/water-based CO<sub>2</sub> removal system

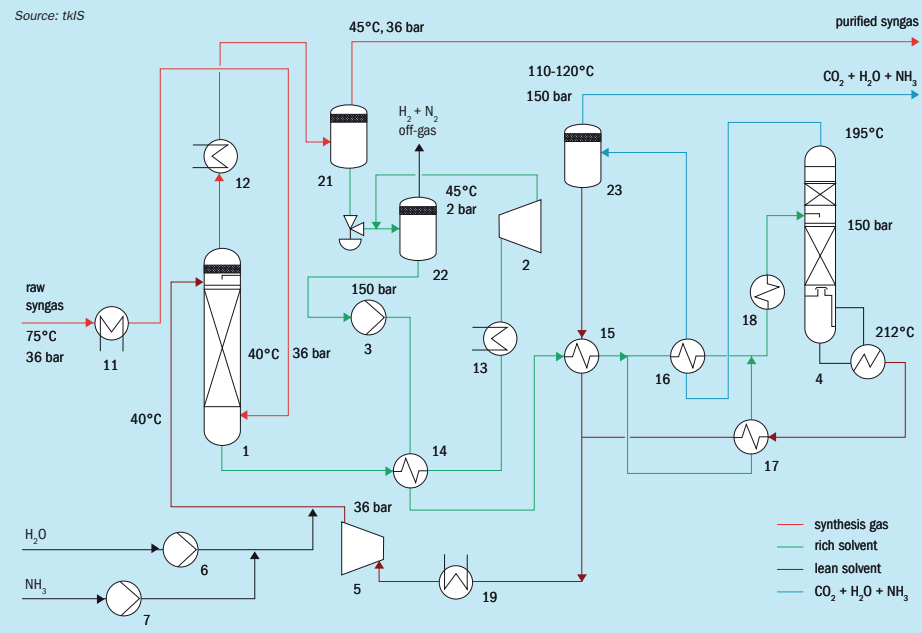

Table 1: Characterisation of the new CO<sub>2</sub> removal system CO<sub>2</sub> recovery at urea synthesis pressure, typical purities

Component	Species concentration in mol% wet	
	purified syngas	CO <sub>2</sub> to urea synthesis
Carbon dioxide	0.0495 (495 ppm)	97.98
Hydrogen	71.47	0.49
Nitrogen	25.37	0.08
Ammonia	1.6	0.36
Carbon monoxide	0.4	traces
Argon	0.3	traces
Methane	0.63	traces
Water	0.18	1.08

Source: thIS

ammonia and water make-up are provided.

Table 1 contains typical purities for the synthesis gas leaving the absorber as well as for the CO<sub>2</sub> supplied to the urea synthesis achieved by the new ammonia/water based CO<sub>2</sub> removal system.

Hydrogen yield of the new ammonia/water based CO<sub>2</sub> removal system is in the

order of 98.3%. About 98.4% of the carbon dioxide entering the absorber is recovered and available for urea production.

Due to the relatively high vapour pressure some ammonia from the solvent supplied to the absorber enters the gas phase and leaves the absorber with the treated synthesis gas. As this ammonia is passed

on to the ammonia synthesis as part of the makeup syngas it is by no means a loss and is simply returned to the solvent of the CO<sub>2</sub> removal system as ammonia makeup.

Some ammonia also remains in the carbon dioxide stream passed on from the CO<sub>2</sub> removal system to the urea synthesis. As this ammonia directly enters the urea synthesis and simply adds to the ammonia supplied to the carbamate formation unit this amount is also not a loss.

Finally a rather small ammonia stream leaves the CO<sub>2</sub> removal system with the off-gas from flash vessel 22 (refer to Fig. 4). Recovery of this amount is in principle possible but most likely not economical. Typically, this off-gas is routed to the reformer burners.

All figures listed have been generated via extensive process simulations based on an existing reference ammonia/urea plant with nameplate capacities of 2,200 t/d ammonia and 3,500 t/d urea. When interpreting these figures it should be taken into consideration that they represent only one possible design case. Substantial modifications are possible without departing from the basic concept if

recommended by plant configuration and/or operating conditions in a specific case. For example, the hydrogen content in the carbon dioxide supplied to the urea synthesis can be further reduced significantly if considered necessary.

The process scheme depicted in Fig. 4 represents only the case when the ammonia and urea plant are both on-stream. However, the new ammonia/water based CO<sub>2</sub> removal system also allows operation of the ammonia plant without the urea plant. In this case, the hot compressed carbon dioxide would have to be re-expanded before being released to the atmosphere. Also, the ammonia content in the CO<sub>2</sub> has to be recovered via absorption with water or regenerated lean solution to meet the local emission limits (e.g. 30 ppmv). During expansion, the CO<sub>2</sub> stream is cooled down to about ambient temperature, thus no additional heating or cooling is necessary.

Depending on the reason and duration of the urea plant shutdown different recovery procedures for the removed ammonia could be chosen. The ammonia-enriched solvent (in fact a weak carbonate/carbamate solution) could be submitted to a distillative ammonia concentration or used in the main CO<sub>2</sub> removal system either as a lean solution or as a make-up stream.

**Steam system and waste heat utilisation modifications**

Replacing the CO<sub>2</sub> removal system (usually amine based) in the conventional ammonia/urea plant by an ammonia/water based system leads to the following major changes in the plant's waste heat utilisation scheme and steam system:

**Liberated amounts of heat and steam**

- Reboiler heat for the desorber column of the conventional CO<sub>2</sub> removal system
- Steam consumption of the CO<sub>2</sub> compressor turbine

**Additionally available waste heat from the new ammonia/water based CO<sub>2</sub> removal system**

- Heat contained in the hot condensate from steam-heated preheater 18 (refer to Fig. 4)

**New energy requirements**

- Heat for desorber feed preheater 18
- Heat for reboiler heat for desorber 4

There are also several other minor changes in energy consumption in condensate

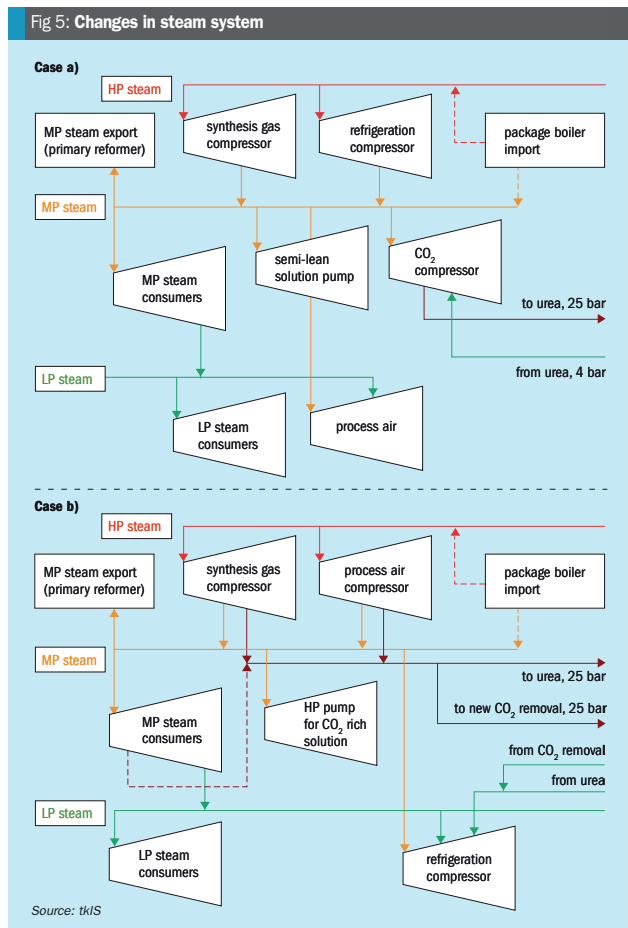

pumps, cooling water pumps, forced draft fan etc. Together they also result in moderate changes in electricity, steam or natural gas consumptions but do not significantly affect the overall picture.

The available thermal energy is predominantly located in the raw ammonia synthesis gas and the hot steam condensate streams present in the new ammonia/water based CO<sub>2</sub> removal system. Both heat streams provide low temperature energy sources with peak temperatures not exceeding 220°C. They are therefore perfectly suited for preheating purposes. Using a part of this low temperature heat, it is possible to preheat more boiler feed

water and produce more high pressure steam in the steam generation section of the ammonia plant. Another possible utilisation of this heat is preheating of the BFW water for the auxiliary boiler, thus directly reducing fuel consumption.

Fig. 5 aims to illustrate the changes required to rebalance the steam system of the entire ammonia/urea plant. Case a) contains a simplified flow diagram of the initial steam system of the reference plant. Case b) represents the reconfigured steam system and the most important changes.

In order to meet the requirements of the new ammonia/water CO<sub>2</sub> removal system and rebalance the plant's steam

Table 2: Qualitative comparison of the major components in amine-based and ammonia/water-based CO<sub>2</sub> removal systems

Component of the CO <sub>2</sub> removal system	Determining parameter	Amine-based	Ammonia/water based	
Solvent	Inventory	€€€	<<<	
	procurement cost	€	€	
	Absorber	Diameter	≈	≈
		Height	<<	<<
Desorber	Temperature	<	<	
	Pressure	≈	≈	
	Procurement cost	€€€	€€€€	
		€€	€€€€	
Packing	Volume	<	<	
	procurement cost	€€€	€€	
Lean solvent pump/ High pressure pump respectively	Mass flow	<<<	<<<	
	Temperature	<	<	
	Pressure change	>>>	>>>	
	Procurement cost	€€	€€€€	
Flash for inerts removal	Pressure	≈	≈	
	Volume	<<<	<<<	
	Procurement cost	€€€	e	

"≈" – value is nearly equal  
 ">" or "<" – value is slightly higher or lower  
 ">>" or "<<<" – value is considerably higher or lower  
 ">>>" or "<<<<" – value is drastically higher or lower  
 "€ - €€€€" – qualitative procurement cost estimate

Source: thIS

system some major changes to the steam system of the conventional ammonia/urea plant are required. The most important one is the introduction of a new medium pressure (25 bar) steam header which now serves the urea plant and the new CO<sub>2</sub> removal system. The new big consumer, the reboiler of the desorber in the new CO<sub>2</sub> removal system, also needs a large amount of 25 bar steam. Together, these two consumers make the 25 bar steam header the second largest header in the steam system of an ammonia/urea complex.

The 25 bar MP steam header is being supplied via extraction steam from both the syngas and the air compressor turbine. Due to elimination of the CO<sub>2</sub> compressor turbine the 25 bar extraction steam from this source is no longer available.

Steam demand from the 50 bar MP steam header is significantly reduced due

to the elimination of the CO<sub>2</sub> compressor turbine and the exchange of process air compressor and refrigeration compressor turbine. Hence, extraction of this MP steam pressure (25 bar) steam header which is also substantially reduced in favour of 25 bar MP steam extraction. Such double extraction turbines and similar steam pressure levels are not uncommon and have been successfully realised in thyssenkrupp Industrial Solutions plants.

**Capital cost reductions**

The new process concept substantially reduces the investment required for an ammonia/urea production plant. Primarily responsible for the capex reduction is the elimination of the entire CO<sub>2</sub> compressor unit with its periphery of interstage coolers, condensate separators, piping etc. and the driver turbine. The total installed costs for the CO<sub>2</sub> compressor unit usually

amount to about 3-4% of the capital costs for the whole ammonia/urea complex.

Replacement of the former CO<sub>2</sub> removal system with the ammonia/water based one is also likely to reduce capital costs as illustrated by the qualitative comparison of some main equipment items presented in Table 2.

However, at the current development stage it is assumed that the capital cost of the ammonia/water system will be in the same order as for the conventional amine based CO<sub>2</sub> wash. Obviously, capital costs for the conventional amine-based CO<sub>2</sub> removal system are well known from formerly built plants. According to internal cost estimations the total cost for an ammonia/water based CO<sub>2</sub> removal system will be about 10-15% below the cost for an amine-based system. Nevertheless, taking into account the limited accuracy of such cost estimations it seems justified to assume equal capital costs for both the old and new removal system. Assumption of equal capital costs also appears advisable for the heat utilisation and steam systems.

**Operating cost reductions**

The new process concept also achieves a considerable reduction of the operating expenditure (opex) of an ammonia/urea production plant. The opex changes are mainly due to lower primary energy consumption and less cooling demand. Also, reduced imports of steam and electricity as well as lower costs for chemicals replacement may provide further savings but on a smaller scale.

**Reduction in primary energy demand**

The lower primary energy demand of the entire ammonia/urea complex is mainly the result of reduced fuel consumption of the auxiliary boiler. The process plants remain fairly unchanged, given the relatively small variations in process gas compositions due to the replacement of the CO<sub>2</sub> removal system. Hence, feed and fuel consumption are practically the same. Due to utilisation of the liberated heat for boiler feed water preheating it is possible to cover the steam demand of the new concept with less energy input.

The result is a 6.1% decrease in auxiliary boiler fuel consumption. This reduction is equivalent to a 1.9% lower primary energy demand for the whole fertilizer complex. During balancing of the steam system some electricity and steam exports could be made available, providing additional

CONTENTS

What's in issue 344

COVER FEATURE 1

Advances in platinum gauzes

COVER FEATURE 2

Urea markets

COVER FEATURE 3

Olefins drive methanol expansions

COVER FEATURE 4

Integration of ammonia/urea plants

NITROGEN+SYNGAS  
ISSUE 344  
NOVEMBER-DECEMBER 2016

BCInsight

Southbank House, Black Prince Road  
London SE1 7SJ, England  
Tel: +44 (0)20 7793 2567  
Fax: +44 (0)20 7793 2577  
Web: www.bcinsight.com  
www.bcinsightsearch.com



opex benefits. The results are summarised in Table 3. All benefits are converted to annual savings in USD assuming 8,300 annual operating hours.

**Changes in cooling duties**

Table 4 illustrates that the overall effect of replacing the amine-based CO<sub>2</sub> removal system with the ammonia/water wash on cooling demand is positive, i.e. results in a net reduction in plant cooling duty of about 7% in comparison with the reference plant. This corresponds to savings in the order of \$1.6 million/year, assuming 8,300 annual operating hours and a price of \$0.1/tonne of cooling water.

The major reason for the reduced overall cooling duty is the elimination of the CO<sub>2</sub> compressor unit which also removes the cooling duties required for the turbine condenser and the interstage coolers. Further important reductions in cooling duties are caused by the changes in turbine operations. The main high-pressure steam consumers now provide significant amounts of 25 bar medium pressure steam and less 50 bar steam. This means a further expansion of the steam amounts not extracted at 50 bar inside the turbines from 50 bar to 25 bar and the respective generation of additional mechanical power. Hence, less steam is required in the low pressure sections of the turbines to generate the shaft power the turbines have to provide, consequently leading to lower condenser cooling duties.

The ammonia/water CO<sub>2</sub> removal system itself does not contribute to the cooling duty reduction. The lean solution cooler and the CO<sub>2</sub> cooler are eliminated, but new cooling requirements for the gas and liquid phases on various process stages appear. At present, the cooling demand for the new ammonia-based removal system is about 21% of the overall cooling duty of the entire reference plant, whereas the amine-based CO<sub>2</sub> removal system requires only about 14%.

**Conclusion and outlook**

Integration of process plants operating in direct sequence often leads to savings in production and/or capital costs. In the case of ammonia and urea plants in a fertilizer complex this approach has also been investigated several times. A number of concepts for fully integrated ammonia/urea plants has been published but so far none has been successfully realised in a production plant.

Table 3: Summary of changes in operating costs: economic effect on entire complex due to change of the CO<sub>2</sub> removal system

Component/position of running costs	Unit price, \$	Annual savings, 1,000 \$
Primary energy demand (natural gas)	4/MMBtu (LHV)	2,415
Steam import	4/MMBtu (LHV)	326
Electricity import	4/MMBtu (LHV) (in natural gas equivalent)	181
Cooling demand (see Table 4)	0.1/t cooling water	1,570
Solvent makeup due to loss/degradation	confidential	94
<b>Total</b>		<b>4,586</b>

Annual operating hours – 8,300

Source: tkfS

Table 4: Comparison of cooling duties: changes in cooling demand in % of the reference case

Cooling Demand	Amine based CO <sub>2</sub> removal system (reference case)	Ammonia/water based CO <sub>2</sub> removal system
Condenser of CO <sub>2</sub> compressor turbine	12.3	0.0
Cooling duties for all other turbine condensers except CO <sub>2</sub> compressor turbine	73.5	71.5
Cooling duties for CO <sub>2</sub> removal system	14.2	21.4
<b>Overall</b>	<b>100.0</b>	<b>92.9</b>

Source: tkfS

This article presents an alternative concept developed by thyssenkrupp Industrial Solutions. It uses some of the elements characteristic of the fully integrated plant concepts, but avoids the major difficulties associated with these schemes. The concept has the potential to reduce both specific energy consumption and capital costs of ammonia/urea fertilizer plants significantly and thus improve the economics of such plants for any given set of plant conditions.

Its full cost saving potential can be exploited when it is applied in a newly built ammonia/urea fertilizer complex. It may, however, also be a viable alternative in revamp situations of existing plants. Especially in cases where the CO<sub>2</sub> compressor and/ or the existing CO<sub>2</sub> removal

system do not have spare capacity and thus would also require major upgrades an ammonia based CO<sub>2</sub> wash installed in parallel to the existing units could be a cost efficient option.

**“The concept has the potential to reduce both specific energy consumption and capital costs of ammonia/urea fertilizer plants significantly.”**

A secondary but still important advantage of the thyssenkrupp Industrial Solutions concept is that stand-alone operation of the ammonia plant with the urea plant in hot standby or complete shutdown is still possible.

The investigations carried out so far have not shown any principal difficulties preventing realisation of the new concept. Also, no serious obstacles have been identified which might put economic viability in question. Further development work is ongoing specifically focussed on areas which are considered most critical from the technical side. ■

integer

insight beyond numbers

Early Bird Discount\*

SAVE \$600

Use the discount code **bcinsight** when booking your delegate ticket.

**Value Added Fertilizer Summit Asia 2017**

Improving margins with new technologies and solutions

15-16 February Singapore

SPECIALTY FERTILIZERS | NPK COMPOUNDS | PREMIUM MICRONUTRIENTS

Slow and controlled release nitrogen fertilizer

Stabilisers and inhibitors

Phosphate management products

NPK compounds

Water-soluble fertilizers

Premium micronutrients

**Selection of Key Speakers**

- ▶ Anil Chandramani, *Chief Investment Officer International Finance Corporation*
- ▶ John A. Hassell, *Research Manager, Global Innovation Technologies Koch Industries*
- ▶ Ravi Prasad, *President - Marketing Coromandel International Limited*
- ▶ Teferi Belayneh, *R&D Manager Omnia Fertilizers*
- ▶ Dale Edgington, *Purchasing & Production Manager Advanced Micronutrient Products*
- ▶ Xinping Chen, *Professor China Agricultural University*

More speakers will be revealed over the next few days and weeks...



**Oliver Hatfield**  
Director of Fertilizers and Chemicals  
Integer Research



Integer's market-leading analysts have forecast an impressive year on year growth rate in excess of 6% over the next decade for the value added fertilizer sector - making it the fastest growing fertilizer sector in this period.

This presents a great opportunity - and Value Added Fertilizer Summit Asia 2017 (VAFSA 2017) is the must-attend event for you to ensure you capitalize on this opportunity.



For more information or to book your delegate place visit [www.integer-research.com/conference/vafsa-2017](http://www.integer-research.com/conference/vafsa-2017) or email [conferences@integer-research.com](mailto:conferences@integer-research.com)

\* Early Bird Discount ends November 18<sup>th</sup> 2016.

CONTENTS

What's in issue 344

COVER FEATURE 1

Advances in platinum gauzes

COVER FEATURE 2

Urea markets

COVER FEATURE 3

Olefins drive methanol expansions

COVER FEATURE 4

Integration of ammonia/urea plants

NITROGEN+SYNGAS  
**ISSUE 344**  
NOVEMBER-DECEMBER 2016

**BCInsight**

Southbank House, Black Prince Road  
London SE1 7SJ, England  
Tel: +44 (0)20 7793 2567  
Fax: +44 (0)20 7793 2577  
Web: [www.bcinsight.com](http://www.bcinsight.com)  
[www.bcinsightsearch.com](http://www.bcinsightsearch.com)

# Methanol to CMTX technology

**Dr Gan**, senior technology advisor for Shanghai Bi Ke Clean Energy Technology Co. Ltd. (CECC) and **Alan Ingham**, licensing manager at Johnson Matthey discuss the latest developments in their CMTX technology.

Methanol to olefins is a growing market, particularly in China where the use of their coal resources allows the country to reduce its dependence on oil derived olefins by producing methanol as an intermediary step before using one of the technologies available to convert this methanol into the desired olefin product.

CECC, a subsidiary of the China Academy of Science, has developed its CMTX technology over the past six years to compete with and complement the existing methanol to olefins (MTO) and methanol to propylene (MTP) technologies, but with the aim of focusing on the production of propylene and butene, for which there is a gap in the current technology offering for olefins.

The CMTX process has now been demonstrated in a 20,000 t/a unit, independently verified by a third party review, and is now ready to be introduced to the mar-

ket. The commercialisation and continued development of the CMTX technology will be done in collaboration with Johnson Matthey. Integrating Johnson Matthey's proven capability in commercialising new technology along with its global market reach will accelerate this process.

## Market background

Methanol to olefins (MTO) is currently the most widely used technology in China for the production of C2 and C3 olefins, but there are other technologies available which focus on producing longer chain olefins. These include methanol to propylene (MTP), which predominantly produces C3s, methanol to gasoline (MTG), which produces gasoline (C5+), and methanol to aromatics (MTA) which targets the production of benzene, toluene and xylene (BTX). A graphical representation of the selectivity of the

various technologies is shown in Figure 1. This shows that there is currently a gap for the production of the C4 olefin, a market that, along with propylene, the methanol to X (MTX) technology is looking to fill. The selectivity of the MTX process results in a mixture of propylene and butene being produced which means that these are the two primary markets of interest.

## Propylene

Since 2009, annual global propylene consumption has grown on average by approximately 5%. Asia-Pacific is the largest market for propylene, within which China is the biggest consumer and India is the fastest growing market. The typical uses of propylene are shown in Figure 2, with the relative consumption of propylene to produce each downstream product indicated by the size of the box.

## Butene

In contrast to propylene, the supply of butene is forecast to decrease markedly over the coming years. This is due, in part, to an increasing amount of light feedstocks, like ethane and propane, being used for steam cracking, which results in less heavy hydrocarbons, including butene, being produced. In addition, in countries like China there also is an initiative to reduce their dependence on crude oil. The Chinese supply of butene is predominately from fluidised catalytic cracking (FCC) and steam cracking (SC) and this production is predicted to decrease by approximately 40% by 2030. This is driven by the Chinese government policy that more than 40% of olefins should be produced by alternative feedstocks – other than crude oil. Currently this policy is being met by a continuing increase in olefins production

Fig 1: Major product selectivity versus carbon number for different technologies

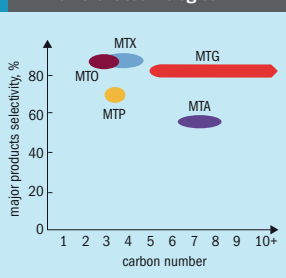

Fig 2: Propylene consumption to produce downstream products

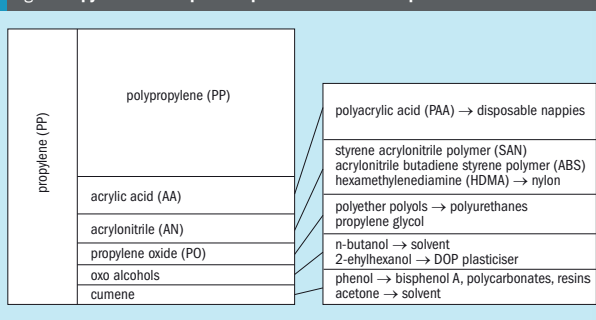

Fig 3: Butene consumption to produce downstream products

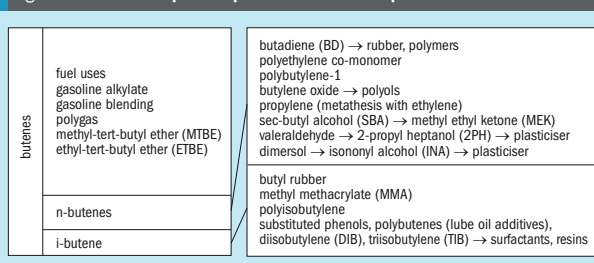
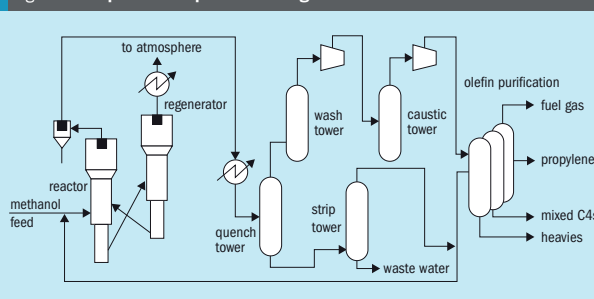

Fig 4: CMTX process simplified flow diagram



using MTO and MTP technologies as well as propane dehydrogenation, which further reduces the supply of butenes.

In contrast to the predicted decrease in supply of butene, the growth in demand is forecast to increase, particularly in China, which is expected to follow GDP growth of 6-7% over the coming years. This increase is driven primarily by its use in fuels, as shown in Figure 3, with the relative consumption of butene to produce each downstream product indicated by the size of the box.

While the majority of butenes produced go into fuel use, other products rely on pure streams of n-butene or i-butene and therefore the selectivity of the butenes produced by the process is important. Table 1 gives a typical selectivity for the MTX process in the production of C4 hydrocarbons. This shows that 92% of all C4s produced by the process are butenes, 37 wt% of which are i-butene. This product composition is very familiar to refinery operators as Raffinate I.

## The CMTX Process

The CMTX process uses methanol to produce propylene and butene in a circulating fluidised bed reactor. The process consists

of several major units, including reaction and regeneration, quenching and washing, compression and olefin purification.

Figure 4 illustrates a simplified flow diagram of the CMTX process. Methanol is introduced to the reactor after being vapourised and superheated and the methanol dehydration reaction takes place over the CMTX catalyst. As in the MTO process, the hydrocarbon products in the reactor can continue to react inside the catalyst to form coke, which results in a reduction in the catalyst activity. Therefore, to maintain the catalyst activity the catalyst is regenerated continuously by burning off the coke. The reaction is carried out at a temperature of around 480-520°C and at a pressure of around 0.15MPaG. Due to the particular structure of the catalyst, the coke selectivity of the CMTX catalyst is very low and it can be regenerated at a relatively low temperature compared to other processes. The regeneration process is carried out at a temperature of around 360-460°C and at a pressure of around 0.10-0.15MPaG.

Before going to the quenching unit, the reactor effluent is first passed through several grades of cyclones to capture the small amount of catalyst fines present in the

Table 1: Typical C4 composition for the MTX process

Components	Average wt%
i-butane	5.5
n-butane	1.9
i-butene	36.7
butene-1	15.1
butene-2	40.2
1,3-butadiene	0.6
butyne	0
<b>Total</b>	<b>100</b>

stream. The reactor effluent is then cooled by generating steam. For the regenerator, the effluent is also cooled by generating steam before it is discharged to atmosphere. In the quenching unit, the reactor effluent is quenched rapidly by water. In the quenching tower, most of the water, oxygenates and fine catalyst particles are separated out. The water from the bottom of quenching tower is stripped to recover any unreacted methanol and DME before being sent to the waste water treatment unit.

Hydrocarbon products from the top of the washing tower are compressed before entering the caustic tower, which removes acidic gases like carbon dioxide. The hydrocarbon products from the top of the caustic tower are again compressed before being sent to the olefin purification section to separate out the major products, propylene and butene. Some of the hydrocarbon by-products which have been separated out in the olefin purification unit are then recycled back to the reactor, which improves the yield of the desired products.

## Key features

There are five key features of the CMTX process which gives it an advantage over the competing technologies.

The first is the ability to achieve a higher weight hourly space velocity (WHSV) over the catalyst in the reactor due to the type of catalyst used. The higher space velocity allows the same capacity to be achieved in a smaller reactor, or an increase in the maximum capacity, when compared to other process designs which represents a significant cost saving for the reaction-regeneration system.

The second is the catalyst used in the CMTX process has a lower coke selectivity and catalyst regeneration temperature when compared to other technology catalysts. This has the advantage of reducing the size of the regenerator required, lowering the regeneration energy consumption

## CONTENTS

What's in issue 344

## COVER FEATURE 1

Advances in platinum gauzes

## COVER FEATURE 2

Urea markets

## COVER FEATURE 3

Olefins drive methanol expansions

## COVER FEATURE 4

Integration of ammonia/urea plants

NITROGEN+SYNGAS  
ISSUE 344  
NOVEMBER-DECEMBER 2016

BCInsight

Southbank House, Black Prince Road  
London SE1 7SJ, England

Tel: +44 (0)20 7793 2567

Fax: +44 (0)20 7793 2577

Web: www.bcinsight.com  
www.bcinsightsearch.com



and increasing the carbon efficiency of the process. This not only reduces the capital expenditure of the plant but also has operating expenditure savings, along with reduced environmental emissions.

The third is the low water/methanol ratio required by the process. This low ratio results in a lower energy consumption for feedstock vaporization and a lower amount of waste water produced. This reduces the operating costs of the plants as well as a reduction in waste water treatment costs.

A comparison of the key operating conditions for the CMTX process and the closest competing technologies, MTO and MTP are shown in Table 2. This table highlights the advantages of the CMTX process for the first three key features mentioned above.

The fourth key feature is the selectivity of the catalyst used in the CMTX process, as the catalyst favours the production of propylene and butene. This is what differentiates the CMTX process from all the other available technologies and means that the CMTX process can be used to produce high value products, which maximises the return on investment.

Lastly, the focus on the production of propylene and butene, reduces the size and Opex of the downstream separation units due to the higher density and higher boiling points of the products in comparison to MTO and MTP processes.

### Development

The CMTX process, although similar to the MTO and MTP processes, has 18 patent applications, three of which have already been granted, which highlights that it is a process with innovative technology. The development of the process started in 2010 with the initial development of the catalyst for the process. Testing of the process on a 300 t/a pilot plant began in 2013 and was completed at the beginning of 2014. The success of this pilot plant enabled the process to be scaled up to a 20,000 t/a demonstration unit, and by the middle of 2015 the test work was completed to confirm the success of the process and verify the performance of the catalyst.

In order to further verify the process a technology appraisal was organised by the China Petroleum & Chemical Industry Federation in July 2015. This completed appraisal confirmed the validity of the results from the demonstration unit and the performance of the process. Following this successful evaluation, the next step of the commercialising the technology has begun.

Table 2: Typical process operating conditions for CMTX, MTO and MTP

Technology	Units	CMTX	MTO	MTP
Reaction temperature	°C	450-520	450-480	450-480
Reaction pressure	MPaG	~0.15	~0.15	~0.10
Water/methanol	Wt	< 0.25	< 0.25	0.7-1.0
Methanol WHSV	h-1	8-10	4.5	~0.7
Regeneration temperature	°C	360-400	600-650	450-480

Table 3: Process performance comparison

Case	Base			Max propylene			Max butene		
	CMTX	MTO	MTP	CMTX	MTO	MTP	CMTX	MTO	MTP
Units	wt%	wt%	wt%	wt%	wt%	wt%	wt%	wt%	wt%
Ethylene	8.6	44.8	2.6	2.2	42.0	2.6	3.3	42.3	3.2
Propylene	46.3	40.8	67.3	75.6	41.1	67.3	48.5	37.0	46.7
Butene	33.4	2.3	2.1	6.3	3.3	2.1	36.2	8.2	29.6
<b>Total</b>	<b>88.3</b>	<b>87.9</b>	<b>72.0</b>	<b>84.1</b>	<b>86.4</b>	<b>72.0</b>	<b>88.0</b>	<b>87.5</b>	<b>79.5</b>

### Performance comparison

In order to assess the performance of the CMTX process, a comparison was made against the two closest technologies, MTO and MTP. There is a range of product flexibility for each process depending on the streams that are recycled back to the reactor. Therefore, in Table 3 three cases are considered;

- 1) Base case – the normal operating product selectivity
- 2) Maximum propylene case – maximising the production of propylene
- 3) Maximum butene case – maximising the production of butene

Recycle streams for Table 3:

<b>CMTX</b>	
Base:	C5 and part of C6+
Max Propylene:	C2, C4 and part of C5+
Max Butene:	C2, C5 and part of C6+
<b>MTO</b>	
Base:	C4 and C5+
Max Propylene:	C4 and C5+
Max Butene:	C5+
<b>MTP</b>	
Base:	C2, C4 and part of C5+
Max Propylene:	C2, C4 and part of C5+
Max Butene:	C2, C5 and part of C6+

There are two important trends shown in Table 3, the first of which is the flexibility of each process. By recycling all or a large portion of the undesired lighter and heavier hydrocarbons, it is possible to increase the selectivity towards a desired product. If the desired product is propylene or butene then only the CMTX and the MTP process have the ability to increase their selectivity towards

these products and in this circumstance, it is possible to achieve a higher selectivity to the desired product using the CMTX process compared to the MTP process.

The second important trend is the overall conversion of methanol to olefins and in all three processes the aim is to maximise the production of olefins. From Table 3 above it can be seen that the CMTX and the MTO process have a similar high overall conversion to olefins and in all cases this conversion is significantly higher than the MTP process. This is mainly because the MTP process employs a fixed-bed reactor process which results in a higher selectivity to coke and heavier hydrocarbons.

### Conclusion

CECC and Johnson Matthey are able to provide operators with a CMTX process that maximizes the production of olefins from methanol and has the flexibility to specifically target propylene and butene to fill the gap that exists with the process technologies currently available. The CMTX process has been shown to outperform similar technologies in the co-production of propylene and butene for a lower capital investment with a lower energy consumption, allowing operators to realise the enhanced value that the CMTX technology offers. ■

### References

1. Chemical Economics Handbook: Propylene, issued in February 2015 by IHS.
2. 'MTX' CECC's technology for methanol to C3/C4 olefins, February 2016, Johnson Matthey conference.

# Waste to power

Ammonia production is a very energy intensive process. A Pandey of OPRA Turbines discusses the utilisation of byproduct gases released during the production of ammonia in energy conversion equipment like gas turbines to generate power and heat simultaneously. The gas turbine based cogeneration solution has the potential to save a significant amount of expensive fuel, reducing the cost of operation and specific CO<sub>2</sub> emissions per tonne of ammonia produced.

Ammonia production is the most energy-intensive process in nitrogen fertilizer production. This puts ammonia plants under scrutiny to reduce greenhouse gas emissions. Often ammonia producers are under pressure to reduce production costs in conjunction with higher production gains to be competitive in the market.

Energy in terms of electricity and heat, is an essential input for the ammonia industry, and ensuring its reliability and affordability is key for sustained development. Development of new energy systems via implementation of advanced energy conversion equipment is essential to realise these goals. Recent developments in the gas turbines industry to address energy efficiency and flexibility to operate on unconventional fuels has created new opportunities for ammonia plants.

Gas turbines are a type of internal combustion engine. They primarily consist of a compressor, a turbine and a combustor (Fig. 1). Gas turbines can be described by the Brayton cycle, in which air is compressed to a high pressure in the compressor section. Fuel is added to this compressed air in the combustor, providing a high temperature and high pressure gas. This hot gas is expanded through the turbine to produce mechanical power. Part of this mechanical power is consumed by the compressor. The remaining mechanical power can be converted into useful power such as electricity in power generation turbines. Gas turbines offer the most feasible cogeneration opportunities for users that have a minimum of 2:1 heat to power ratio.

### Integration of energy generation systems

The following processes can be used to manufacture ammonia:

- steam reforming of natural gas;

- partial oxidation of heavy oil or waste oil;
- gasification of coal.

Steam reforming of natural gas is the most commonly used process for the manufacture of ammonia and 80% of world ammonia production is based on this concept. Fig. 2 shows the typical manufacturing process of ammonia from steam reforming of natural gas.

Ammonia production via steam reforming of natural gas is very energy demanding on account of heat inputs required at various stages during the process. The heat to power ratio at ammonia plants is typically higher than 3:1, implying there is a good match for gas turbine based cogeneration at these plants.

High prices of natural gas in certain regions of the world and regulations to reduce greenhouse gases puts manufacturers under pressure to produce ammonia

at competitive prices. It is therefore of interest to reduce the reliance on natural gas or other fossil fuels for energy generation at ammonia plants. However, energy generation is typically achieved through the use of conventional energy conversion equipment like auxiliary boilers, gas turbines, steam turbines or engines operating on natural gas or other fossil fuels.

Alternative fuel sources within the ammonia plant to generate energy have the potential to control the cost of energy production. This can be done by using new generation gas turbines that can run on unconventional fuels like tail gas from the purge gas recovery unit (PGRU) or synloop purge gas. To understand the behaviour of tail gas we need to understand the ammonia synthesis process. Ammonia synthesis is operated in loop mode, since the conversion per pass is only 20-30%. The synthesis gas contains small quantities of

Fig 1: OP16 gas turbine system

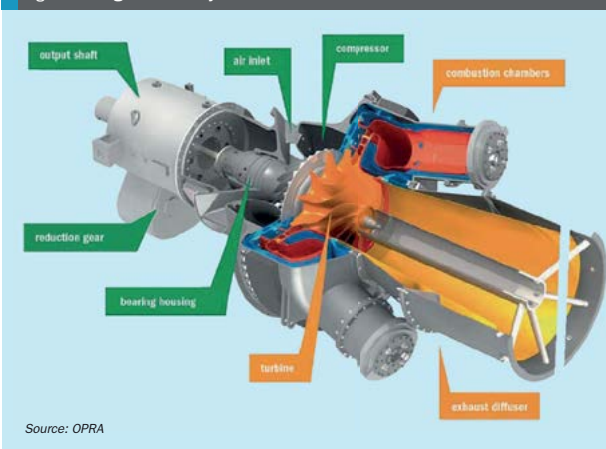

Source: OPRA

## CONTENTS

What's in issue 344

## COVER FEATURE 1

Advances in platinum gauzes

## COVER FEATURE 2

Urea markets

## COVER FEATURE 3

Olefins drive methanol expansions

## COVER FEATURE 4

Integration of ammonia/urea plants

NITROGEN+SYNGAS  
ISSUE 344  
NOVEMBER-DECEMBER 2016

BCInsight

Southbank House, Black Prince Road  
London SE1 7SJ, England

Tel: +44 (0)20 7793 2567

Fax: +44 (0)20 7793 2577

Web: www.bcinsight.com  
www.bcinsightsearch.com

Fig 2: Block diagram of ammonia manufacturing process

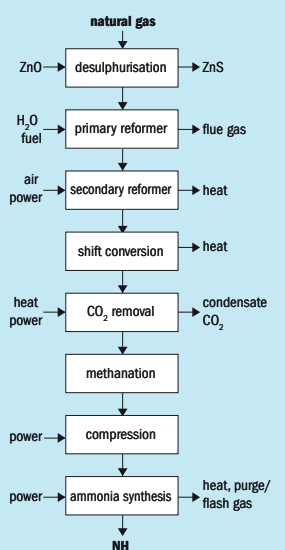

Source: OPRA

methane and argon (inerts), which build up in the loop. In order to achieve optimum conversion it is necessary to purge a certain quantity of gas from the synthesis loop to reduce the concentration of these inerts. This purged gas from the synthesis loop, also called synloop purge gas, contains high amounts of hydrogen, which can be recovered by installing a purge gas recovery unit (PGRU). The tail gas is derived as a byproduct gas from the PGRU after hydrogen recovery from synloop purge gas. The typical molar composition of tail gas from the PGRU and synloop purge gas is shown in Table 1.

The tail gas from the PGRU and the synloop purge gas have low and fluctuating calorific values making it difficult for them to be used in conventional gas turbines. On account of the high hydrogen content of these gases they can cause knocking in conventional reciprocating engines.

To tackle different fuels OPRA has developed specific combustors for its OP16 series of gas turbines. The OP16 gas turbine is specified with different combustor options i.e. 3A, 3B or 3C depending on the fuel and emissions requirements. The

Fig 3: Gas turbine schematic for ammonia plant

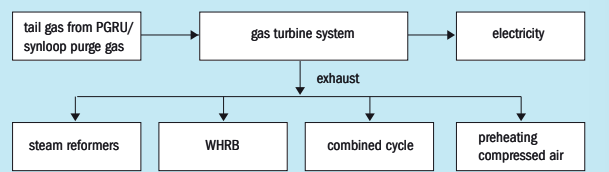

Source: OPRA

Table 1: Molar composition of tail gas from PGRU and synloop purge gas

	Tail gas from PGRU	Synloop purge gas
<b>Molar composition</b>		
CH <sub>4</sub> , mol-%	25.0	10.0
H <sub>2</sub> , mol-%	15.0	63.0
Ar, mol-%	10.0	5.0
NH <sub>3</sub> , mol-%	0	2.0

Source: OPRA

OP16-3A and 3B gas turbines are designed for high calorific value fuels such as natural gas, diesel, well-head gas, LPG along with low emissions requirement. The third variation of the OP16 series of gas turbines, the OP16-3C, is capable of burning low calorific gaseous and liquid fuels like tail gas from the PGRU and synloop purge gas.

The OP16-3C is a new generation gas turbine allowing industrial users to burn a variety of low calorific value fuels in it to generate reliable and continuous energy. Industries like ammonia manufacturers can make use of these gas turbines to generate energy from free fuel sources. This results in a reduction of CO<sub>2</sub> emissions from the plant along with sustainable generation of energy.

In order to make the most efficient use of the gas turbines it is wise to operate them in cogeneration mode. The objective of a gas turbine based cogeneration scheme (Fig. 3) is to produce electricity and to use the high grade thermal energy (hot gases at 580°C) from the exhaust of the gas turbine for one of the following purposes:

- Steam reformer: Reformers are typically operated at temperatures between 500-800°C, depending on the reforming stage. A gas turbine with high exhaust

temperature matches this demand. In addition, gas turbine exhaust contains around 14% O<sub>2</sub>, which enables post-combustion to increase the temperature of hot air temperature entering the reformer, without adding fresh air. At present the heat for the primary reforming process is supplied by burning natural gas or other gaseous fuel, in the burners of a radiant box containing the tubes. Thus the use of natural gas can be replaced by freely available hot gases from gas turbines.

- Waste heat recovery boiler (WHRB): Using the hot gases from the gas turbine's exhaust in a WHRB to generate steam for the use in the ammonia process or to drive a steam turbine. Again the exhaust can be post-combusted to match the steam demand of the plant without adding fresh air to the boiler, resulting in higher efficiency of steam generation.
- Combined cycle: The exhaust of the OP16 gas turbine can be used in the existing boiler to produce steam and thereby electricity in a combined cycle mode.
- Preheat the compressed air: In the secondary reformer internal combustion of a part of the feed gas with the process air is done to increase the conversion rate of ammonia. This process air also provides the nitrogen for the final synthesis. The process air is compressed to the reforming pressure and heated further in the primary reformer to around 600°C. This process air can be preheated with the gas turbine's hot exhaust gases thus reducing feed gas consumption.

All of the above-mentioned uses of the gas turbine's exhaust result in higher combined efficiency of the system based on a free fuel i.e. tail gas from the PGRU or synloop purge gas. Such a solution reduces the CO<sub>2</sub> and NO<sub>x</sub> emissions that are otherwise created from direct combustion of these fuels in a reformer or auxiliary boilers to generate heat.

Table 2: OP16-3C gas turbine performance data at ISO conditions

Parameters	Value
Maximum electric power, kW	2,073
Thermal efficiency, %	26.2
Electrical efficiency, %	25.4
Generator efficiency, %	97
Fuel flow, kg/s	0.741
Fuel flow, Nm <sup>3</sup> /h	2,700
Exhaust gas temp, °C	581
Exhaust gas flow, kg/s	9.5
Exhaust heat, kWt	5,432

Source: OPRA

In order to check the compatibility of the gas turbine, as a starting point, process flow and thermal requirements (pressure, temperature and steam flow rate) have to be analysed.

It may be necessary to add post-burners to match steam parameters required by the process. Depending on whether the turbine is desired to be operated in island mode or in grid-parallel mode, a few simple power connection modifications may also be necessary.

Most ammonia plants operate 24/7, making them ideal for gas turbine cogeneration plants. Gas turbines need minimal maintenance and down time. They are continuous machines that can operate for extended periods. The OP16 gas turbine, for instance, requires an inspection for every 8500 hours of operation. Equivalent to 354 days, this period can be scheduled to match the annual plant maintenance period. In addition, the OP16 gas turbine requires one major overhaul for every 42,500 hours of operation. Implementation of gas turbine cogeneration at an existing ammonia plant is a common practice and it does not require significant modifications.

**Feasibility study**

The technical and economic feasibility of gas turbines used for power and heat generation in ammonia plants, is a key tool to understand the actual implementation of such a solution. Table 2 shows the performance characteristics of OP16-3C gas turbine running on tail gas from the PGRU at ISO conditions.

Table 3: Feasibility analysis of OP16-3C gas turbine

Parameters	OP16-3C cogeneration	Base case
Annual electricity production, kWh	16,584,000	0
Annual electricity purchase, kWh	0	16,584,000
Annual gas consumption, Nm <sup>3</sup> /h	21,600,000	17,318,498
Electricity price, IDR/kWh (\$/kWh)	1,200 (0.09)	1,200 (0.09)
Annual electricity expenses, IDR (\$)	0	19,900,800,000 (1,529,238)
Gas price, IDR/MMBtu	0	0
Annual gas expenses, IDR (\$)	0	0
Long term service agreement expenses*, IDR (\$)	449,544,000 (34,553)	0
Annual operating expenses, IDR (\$)	449,544,000 (34,553)	19,900,800,000 (1,529,238)
Annual operating savings, IDR (\$)	19,451,256,000 (1,495,157)	0
Payback period, years	1.8	-

\* The above feasibility analysis takes into account the following investments costs: OP16-3C gas turbine genset; waste heat recovery steam boiler; compressor for tail gas pressurization; EPC costs for installation; maintenance costs for gas turbine. Source: OPRA

As shown in Table 2, one OP16-3C gas turbine is capable of producing 2 MW of electricity by using tail gas from PGRU as fuel. The resultant heat coming out from the gas turbine can be used for various purposes as already mentioned. This simultaneous production of heat and power using the OP16-3C gas turbine results in a combined efficiency of approximately 85%.

Table 3 compares the gas turbine based cogeneration to a base case where gases like tail gas from the PGRU are used in a furnace to produce only steam. It is quite evident that new generation gas turbines are capable of utilising byproduct gases from ammonia plants with increased efficiency. By making use of such a technology the ammonia plants can achieve high operational savings in terms of electricity and heat production. The feasibility is based on Indonesian currency IDR (Indonesian Rupiah).

The above feasibility analysis takes into account the following investments costs:

- OP16-3C gas turbine genset;
- waste heat recovery steam boiler;
- compressor for tail gas pressurisation;
- EPC costs for installation;
- maintenance costs for gas turbine.

The OP16 is designed for minimal maintenance requirements with long service intervals. The above LTSA agreement expenses is for basic level which includes the following services:

- contract duration: 5 years;
- 24/7 hotline;
- remote monitoring;
- annual inspections;
- labour;
- spare parts.

**Conclusions**

New generation gas turbines that are capable of operating on off spec fuels like tail gas from PGRU and synloop purge gas hold the potential to reduce emissions and lower the production costs at ammonia plants. Operation of gas turbines such as the OP16-3C result in efficient generation of valuable electricity and heat from free fuel source with a quick payback period. As a result of the feasibility analysis, it is seen that OP16-3C gas turbine genset in cogeneration mode will produce annual operational savings of around IDR (Indonesian Rupiah) 19,451,256,000 (\$1,495,157) in the Indonesian market. These savings in turn will pay back the complete investment for the OP16-3C gas turbine installation within 1.8 years of operation. The application of this technology is also viable in ammonia plants in other countries around the world. ■

**References**

1. Best Available Techniques for Pollution Prevention and Control in the European Fertilizer Industry, 2000.

www.nitrogenandsyngas.com



# Creating new value from under-utilised hydrogen systems



**Sam Golan**, CEO of Primus Green Energy looks at using his company's *STG+*<sup>TM</sup> (syngas to gasoline) technology as an add-on for refiners to make use of spare hydrogen to create saleable products.

Hydrogen is an important chemical commodity; the market for hydrogen, a starting chemical material used in the oil refining, petrochemical and other industries, is estimated at over \$100 billion worldwide. Currently, most hydrogen (H<sub>2</sub>) is produced through the steam reforming of methane (CH<sub>4</sub>), or natural gas. In the United States, most hydrogen is used onsite at oil refineries for hydroprocessing (hydrocracking and hydro-desulphurisation). Hydrogen is also used at petrochemical plants in the synthesis of ammonia, chlorine, hydrogen peroxide, solvents and other chemicals.

However, despite the high demand for this valuable industrial chemical, production systems at refineries, chemical plants and industrial gas facilities around the world that make hydrogen from natural gas often operate below designed capacity for a variety of reasons. At refineries,

for instance, the demand may decrease due to changes in the input type of crude oil: if a refinery accepts more sweet crude, it will use less hydrogen for desulphurisation. Petrochemical plants may require less hydrogen than originally planned due to variations in regional market conditions. And reformers owned by industrial gas firms are sometimes only partially or intermittently used as swing units to meet peak demands for hydrogen.

Because of the high capital investment and ongoing operational costs for a hydrogen plant, it makes sense to seek ways to monetise excess capacity in order to take full advantage of equipment and boost overall plant returns. One way to do this is through gas-to-liquids (GTL) technologies, which can transform syngas from an underutilised hydrogen production facility into valuable transportation fuels and

chemicals, including high quality gasoline and methanol.

A key unit in a hydrogen production system is the steam methane reformer (SMR). This produces syngas, a mixture of carbon monoxide (CO) and hydrogen, from natural gas. In a hydrogen production facility, the syngas – stripped of its carbon monoxide component – is used as a source of hydrogen. But if the demand for hydrogen declines, the reformer ends up operating at a reduced capacity or sitting idle.

## Using GTL technologies

Which is where GTL technologies come in; GTL production can use syngas as a feedstock to produce high-quality gasoline or methanol – in other words, to turn an underutilised production facility into one that produces high-demand liquid

end products. The range of possible end products allows hydrogen producers to make products that are tailored to market demand. The most desirable end product is typically low-sulfur, zero-benzene gasoline, which can be sold directly into wholesale gasoline markets or used in a refinery blending pool.

But what about cost? In an era of cheap gasoline, can the cost of gasoline produced through GTL technologies compete with that of gasoline refined from crude? The answer is yes: because the cost of gasoline produced through GTL technologies is linked to the price of natural gas, the feedstock used to make syngas, the cost is lower. With natural gas prices at multi-year lows in the US and expected to stay low for years to come, GTL technologies offer hydrogen producers a flexible, economically robust production alternative.

GTL technologies can also produce methanol a versatile chemical used as a basic chemical building block for paints, plastics and solvents. Methanol produced through GTL technologies can be sold into regional markets at prices that are typically cheaper than for methanol transported over long distances from one of the world's handful of methanol mega-plants. In many parts of the world, it is also used as an octane-boosting gasoline additive, which means that refineries with underutilized reformers can use it right onsite.

## Advantages of STG+<sup>TM</sup> technology

While there are many types of GTL technologies, Primus Green Energy's *STG+*<sup>TM</sup> technology is best suited to monetise the excess syngas produced by hydrogen systems. The reasons have to do primarily with its small scale and prefabricated, modular design. The *STG+* technology economically transforms syngas into valuable liquid end products at feed gas flows a fraction of the syngas produced in a 90 million scf/d hydrogen plant. This means that an *STG+* unit can deliver attractive returns from a reformer that is only slightly underutilised. The modular design translates to easy deployment; the scalable units are built offsite, trucked in and installed in only a few months. Indeed, the total time to commissioning is as little as 12 months.

In addition to small scale and modularity, the *STG+* technology also offers other advantages, in terms of:

- Utilities – the unit uses existing onsite electricity and water utilities; as a



Synthetic gasoline from Primus' pilot plant.

The events of recent years have significantly altered the market landscape.

- result, the OSBL (outside battery limits, or offsite) costs are minimal.
- Wastewater treatment – the process water is clean, requiring no treatment; the water can be recycled onsite as boiler feed water or cooling water.
- Labour and maintenance – the unit often can be operated by existing staff.
- Emissions – the unit creates no additional emissions, which means no new air permits are required.
- Feed gas flexibility – the unit can use syngas with a wide variety of compositions as a feedstock; it can also use CO<sub>2</sub>.
- Carbon footprint – the ability to use CO<sub>2</sub> as a co-feed with syngas means that plants can reduce their carbon footprints.
- Additional hydrogen – the unit also produces a steady, reliable vent stream of H<sub>2</sub> that can be used as fuel gas or as an additional source of H<sub>2</sub>.

## Not all GTL technologies are alike

The most well known GTL technology is Fischer-Tropsch, or FT, which was developed in Germany in the 1920s and used by the petroleum-starved Third Reich during World War II to convert coal into diesel. The problem with FT, however, is that it produces a synthetic crude that must be further refined. This adds considerably to the expense, especially at a small scale. Also, the process yields primarily diesel and lubricants rather than gasoline, the most desirable end product. While efforts are underway to develop an FT technology that is economically viable at small scales, the two-step synthesis and refining process is an inherent limitation. Thus far, FT has only been economically viable

at very large plants such as Shell's \$24 billion Pearl plant, located at the massive North Field in Qatar, a fossil fuel-rich state on the Arabian Peninsula.

The other main competing 'GTL' technology is Exxon-Mobil's methanol-to-gasoline (MTG) technology, which was used by Mobil to produce gasoline at a plant in New Zealand for about 11 years starting in 1985. The drawbacks of the MTG technology are its inefficiency, which makes for a higher cost, and the fact that it produces only a single end product, gasoline.

*STG+* technology is more efficient and cost effective than either FT or MTG at small scales, while also offering the same advantages at larger scales.

## Maintaining optionality

A popular saying in the oil and gas industry is that "change is the new constant." The events of recent years – including the economic recession, the introduction of hydraulic fracking, political upheaval in the Middle East and unprecedented price volatility – have significantly altered the market landscape. In such an environment, it is more important than ever to build optionality into to operational models to help outride fluctuations in market demand.

*STG+* allows hydrogen producers to bridge mismatches between production capacity and sudden and/or transformational changes in demand. By putting underutilized reformers to work making valuable liquid end products, hydrogen producers can achieve the optionality that allows them to maintain profitability even when confronted with the unexpected. ■

## Advertisers' index

**Editor:** RICHARD HANDS  
richard.hands@bcinsight.com  
**Technical Editor:** LISA CONNOCK  
lisa.connock@bcinsight.com

**Contributors:**  
LAURA CROSS  
laura.cross@integer-research.com  
MIKE NASH  
mike.nash@ihs.com

**Publishing Director:** TINA FIRMAN  
tina.firman@bcinsight.com

**Subscription rates:**  
GBP 425; USD 850; EUR 655

**Subscription claims:**  
Claims for non receipt of issues must be made within 3 months of the issue publication date.

**Subscriptions Manager / enquiries:**  
MARIETTA BESCHORNER  
Tel: +44 (0)20 7793 2569  
Fax: +44 (0)20 7793 2577  
marietta.beschomer@bcinsight.com  
Cheques payable to BCInsight Ltd

**Advertising enquiries:**  
TINA FIRMAN  
tina.firman@bcinsight.com  
Tel: +44 (0)20 7793 2567

**Agents:**  
**Japan:** (also subscription enquiries)  
KOICHI OGAWA  
O.T.O. Research Corporation  
Takeuchi Building  
1-34-12 Takadanobaba  
Shinjuku-Ku, Tokyo 169, Japan  
Tel: +81 3 3208 7821  
Fax: +81 3 3200 2889

**Previous articles** from *Nitrogen+Syngas* and *Nitrogen & Methanol* from 1996 to the present are available digitally in PDF format. To make a purchase, or for a list of available articles, please see: [www.bcinsight.com](http://www.bcinsight.com)

**Copyright:** *Issued six times per year, or bi-monthly. All rights reserved. No part of this publication may be reproduced, stored in a retrieval system or transmitted in any form or by any means – electronic, mechanical, photocopying, recording or otherwise – without the prior written permission of the Copyright owner.*

ISSN: 1750-6891

**Design and production:**  
JOHN CREEK, DANI HART



**Printed in England by:**  
Buxton Press Ltd  
Palace Road, Buxton, Derbyshire,  
SK17 6AE

© 2016 – BCInsight Ltd

## BCInsight

**Published by: BCInsight Ltd**  
Southbank House, Black Prince Road  
London SE1 7SJ, England  
Tel: +44 (0)20 7793 2567  
Fax: +44 (0)20 7793 2577  
Web: [www.bcinsight.com](http://www.bcinsight.com)  
[www.bcinsightsearch.com](http://www.bcinsightsearch.com)

Advertiser	Page	Contact	Fax / Email
<b>CRU's Nitrogen+Syngas Conference 2017</b>	31	Ms Hayley Ward	hayley.ward@crugroup.com
<b>Casale</b>	26/27	Ms Rosella Gazzaniga	41 91 960 7291
<b>Eurotecnica Contractors and Engineers</b>	5/OBC	Mr Stefano Sassi	s.sassi@eurotecnica.it
<b>Heraeus GmbH</b>	37	Ms Paloma Seidenspinner	49 6181 35 3533
<b>Integer Research</b>	19		<a href="http://www.integer-research.com">www.integer-research.com</a>
<b>Johnson Matthey</b>	IFC	Ms Frances Lynch	44 1642 522 542
<b>Sabin Metal Corporation</b>	9	Mr Bradford Cook	bcook@sabinmetal.com
<b>Saipem</b>	17	Ms Fabia Perrone	39 02 520 54130
<b>Schoeller-Bleckmann Nitec</b>	41	Mr Herman Kernberger	43 2630 31919
<b>Stamicarbon</b>	23	Ms Chantal Spies	31 46 4237001
<b>Tecnimont Group</b>	13	Mr Tommaso Verani	39 6 412235644
<b>Value Added Fertilizer Summit Asia 2017</b>	49		<a href="mailto:conferences@integer-research.com">conferences@integer-research.com</a>

### Next issue: January/February 2017

- Southeast Asian nitrogen markets
- Nitrogen fertilizer project listing
- Process licensors
- Early detection of process risks for improved safety and operational excellence
- 24/7 firebox monitoring in ammonia plants

Full details of features can be found in the 2017 Media Prospectus, download a copy at [www.bcinsight.com](http://www.bcinsight.com)

Closing date for advertisement space booking is 8 December 2016  
For further information and to book advertisement space contact:  
**Tina Firman, Publishing Director:** [tina.firman@bcinsight.com](mailto:tina.firman@bcinsight.com)  
Tel: +44 (0)20 7793 2567 Fax: +44 (0)20 7793 2577

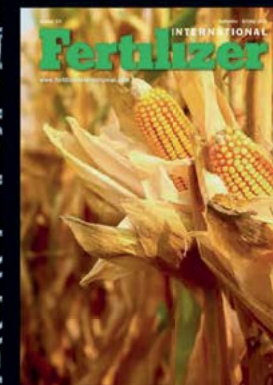
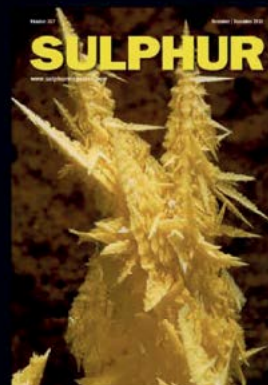

Complete coverage of the international sulphur, fertilizer, related chemicals and raw materials industries in print and online

**BCInsight**  
[www.bcinsight.com](http://www.bcinsight.com)

CONTENTS

What's in issue 344

COVER FEATURE 1

Advances in platinum gauzes

COVER FEATURE 2

Urea markets

COVER FEATURE 3

Olefins drive methanol expansions

COVER FEATURE 4

Integration of ammonia/urea plants

NITROGEN+SYNGAS  
**ISSUE 344**  
NOVEMBER-DECEMBER 2016

## BCInsight

Southbank House, Black Prince Road  
London SE1 7SJ, England  
Tel: +44 (0)20 7793 2567  
Fax: +44 (0)20 7793 2577  
Web: [www.bcinsight.com](http://www.bcinsight.com)  
[www.bcinsightsearch.com](http://www.bcinsightsearch.com)



1  
2  
3  
4  
5  
6  
7  
8  
9  
10  
11  
12  
13  
14  
15  
16  
17  
18  
19  
20  
21  
22  
23  
24  
25  
26  
27  
28  
29  
30  
31



## Melamine

makes our lives more comfortable

Euromel<sup>®</sup>, the trademark of melamine produced at plants licensed by Eurotecnica Group, the leading melamine technology provider since 1978, is the sign of superior melamine quality as witnessed by licensees the likes of QAFCO, MHTL, Grupa Azoty, Petrochina and several others.

Euromel<sup>®</sup> melamine can be found in many objects that surround us, such as dinnerware and household appliances.

Euromel<sup>®</sup> brand is registered in 48 countries representing 85% of the melamine world's consumption.

**WE ARE  
MELAMINE  
TECHNOLOGY**



# Don't forget the next issue of **Nitrogen+Syngas** January/February 2017



CONTENTS

What's in issue 344

COVER FEATURE 1

Advances in platinum gauzes

COVER FEATURE 2

Urea markets

COVER FEATURE 3

Olefins drive methanol expansions

COVER FEATURE 4

Integration of ammonia/urea plants

**NITROGEN+SYNGAS**  
**ISSUE 344**  
NOVEMBER-DECEMBER 2016

**BCInsight**

Southbank House, Black Prince Road  
London SE1 7SJ, England  
Tel: +44 (0)20 7793 2567  
Fax: +44 (0)20 7793 2577  
Web: [www.bcinsight.com](http://www.bcinsight.com)  
[www.bcinsightsearch.com](http://www.bcinsightsearch.com)