

1
2
3
4
5
6
7
8
9
10
11
12
13
14
15
16
17
18
19
20
21
22
23
24
25
26
27
28
29
30
31
32
33
34
35

Welcome to our interactive version of **Nitrogen+Syngas** Issue 341

Please use either the buttons on the left or top right of the page to navigate your way around this interactive PDF

IMPORTANT INFORMATION:

Copyright – Issued six times per year, or bi-monthly. All rights reserved. No part of this publication may be reproduced, stored in a retrieval system or transmitted in any form or by any means – electronic, mechanical, photocopying, recording or otherwise – without the prior written permission of the Copyright owner.

Number 341

May | June 2016

nitrogen + syngas

www.nitrogenandsyngas.com

Long-term fertilizer demand
Challenges for India
Sulphur-enhanced urea
Optimising catalytic reactors

CONTENTS

What's in issue 341

COVER FEATURE 1

Long-term fertilizer demand

COVER FEATURE 2

Challenges for India

COVER FEATURE 3

Sulphur-enhanced urea

COVER FEATURE 4

Optimising catalytic reactors

NITROGEN+SYNGAS

ISSUE 341

MAY-JUNE 2016

BCInsight

Southbank House, Black Prince Road
London SE1 7SJ, England

Tel: +44 (0)20 7793 2567

Fax: +44 (0)20 7793 2577

Web: www.bcinsight.com

www.bcinsightsearch.com

an integrated process for UFC production

Johnson Matthey has used its know-how in ammonia, methanol and UFC* production to develop an integrated process for the manufacture of UFC that will generate substantial savings on an ammonia-urea complex.

The new **FORMOX™** integrated UFC process offers:

- A secure and cost effective supply of UFC.
- Affordable capital investment.
- A simple flowsheet with low operating costs.
- An optimized process based on proven Johnson Matthey catalysts and technologies.

Contact us to find out if the **FORMOX** integrated UFC process can benefit your ammonia-urea plant.

Formox Davy Katalco
Activate your potential

UK Tel +44 (0)1642 553601
SWEDEN Tel: +46 435 380 40

www.jmprotech.com

Johnson Matthey
Process Technologies

*UFC is a mixture of 60wt% formaldehyde, 25wt% urea and 15wt% water.



Cover: Urea bagging plant in Russia. saoirse2013 / shutterstock.com



11
India's challenges
Grappling with increasing fertilizer demand.



26
Catalytic reactors
Improvements in reactor design and catalysts.

Read this issue online at:
www.nitrogenandsyngas.com

Published by:
BCInsight

nitrogen + syngas

www.nitrogenandsyngas.com
NUMBER 341
MAY | JUNE 2016

CONTENTS

- 11 Challenges for the Indian fertilizer industry**
Dr M.P. Sukumaran Nair, director of the Centre for Green Technology & Management, looks at the various challenges facing the Indian fertilizer industry and how it fits into the Modi government's 'Make in India' policy.
- 13 Chasing the gas**
Changing economics and availability of feedstocks are leading to increased interest in moving plants from one location to another.
- 15 Long-term demand for fertilizer**
New nitrogen production plants are predicated on increases in fertilizer demand – something which has seen steady increase for decades now. But can such trends continue indefinitely, or is there a slowdown in global nitrogen demand growth ahead?
- 17 A new approach to sulphur-enhanced urea**
Shell and Uhde Fertilizer Technologies have joined forces to integrate Shell's Urea-ES technology with UFT's fluid bed granulation technology to produce a new sulphur-enhanced urea fertiliser technology.
- 20 Urea+ fertilizer production**
The efficiency and flexibility of NIIK's HSDG technology for the production of various urea+ fertilizer types has been successfully demonstrated in a series of recent trials.
- 21 An introduction to pre-reforming catalysis**
J. Cross, G. Jones and M. A. Kent of Johnson Matthey Process Technologies discuss the catalysis behind pre-reforming in syngas plants. Pre-reforming can provide several benefits in modern hydrogen and ammonia plants including greater feedstock flexibility and improved energy efficiency.
- 26 Optimising catalytic reactors in ammonia plants**
Advances in simulation and analysis tools are being used to improve the design of catalytic reactors in ammonia plants. Further improvements can be made by using high efficiency catalysts and reducing the pressure drop across catalytic reactors.

REGULARS

- 3 Editorial**
4 Price Trends
5 Market Outlook
6 Nitrogen Industry News
8 Syngas News
9 People/Calendar
10 Plant Manager+
Problem No. 36: Change in colour of urea product

CONTENTS

What's in issue 341

COVER FEATURE 1

Long-term fertilizer demand

COVER FEATURE 2

Challenges for India

COVER FEATURE 3

Sulphur-enhanced urea

COVER FEATURE 4

Optimising catalytic reactors

NITROGEN+SYNGAS
ISSUE 341
MAY-JUNE 2016

BCInsight

Southbank House, Black Prince Road
London SE1 7SJ, England
Tel: +44 (0)20 7793 2567
Fax: +44 (0)20 7793 2577
Web: www.bcinsight.com
www.bcinsightsearch.com

China – turning the supertanker



From normal cruising speeds, it reportedly takes 20 minutes to stop a supertanker. Often they will cut engines 25 km from a port and coast to it unpowered. Their turning circle can be over 2 km. China's industrialisation seems to have had the same kind of juggernaut force on commodity markets over the past couple of decades, and the country's current attempt to switch from years of investment-led growth towards more consumption-led growth is surely a feat far more difficult than turning one of the tankers full of oil that has fed China's growth so far.

“The country has added 70 million tonnes of urea capacity in just two decades.”

The Chinese government is attempting something equally profound in nitrogen markets. Up to now, the country's relentless drive to be self-sufficient in food, and hence fertilizer, has led to the largest and most prolonged urea capacity building programme in history, which we are only now coming to the tail end of. China produced 11 million tonnes of urea in 1995, and imported 7 million tonnes, with a total capacity put at 21 million tonnes. In 2015 it produced 75 million tonnes of urea, of which it exported 13 million tonnes, and the country's total urea capacity was estimated at 90 million t/a, meaning that the country has added 70 million tonnes of urea capacity in just two decades, not even counting capacity which has closed during that time (put by CRU at 8.5 million tonnes in the past three years alone). Small wonder then that global urea prices are falling, and falling coal prices in China because of overcapacity in that industry mean that China's producers can also sustain lower urea prices. But even so there is a considerable overhang of what is dubbed “zombie” capacity, which in defiance of normal economic logic keeps on operating in spite of persistent losses. These are generally state-owned firms, sustained by cheap government loans, often integrated with profitable coal production, and kept operating simply to preserve jobs.

Overcapacity is not limited to the nitrogen industry, of course. It is equally true of China's steel, coal, shipbuilding and phosphates industries, and of course its housing market. Some industries are

estimated to be up to 35% oversupplied. However, at the recent March party congress, the Chinese government signalled that tackling ‘supply side’ issues in the economy would be its priority for 2016. According to senior government figures, job losses of around 1.3 million in the coal and 500,000 in the steel industry are expected, and there is now an aggressive policy of merger, consolidation and rationalisation to create larger, more efficient state owned enterprises – large scale privatisation has been ruled out, however.

In the nitrogen sector, the government is aiming to cap capacity at 60 million tonnes N – roughly its current level – by 2020, and bring utilisation rates up from their current 70% to 80%. Closures are likely too, in older, smaller plants, of which China still has a considerable overhang from the decades before its industrialisation. But while we wait for Chinese demand to catch up with supply, there is nevertheless likely to be a lot of Chinese urea sloshing around the global marketplace. The government slashed urea export tariffs in 2014, which has led to the current glut of urea on world market, although exports were running fairly high even before that. With Iran now looking towards completing its various gas-based plants and new capacity coming on-stream in the US based on cheap shale gas, it looks like nitrogen markets are going to have a few lean years before the Chinese supertanker completes its turn. ■

Richard Hands, Editor



Late seventies, Kuwait. Melamine plant under construction

Euromel[®] Melamine Technology

World leading melamine brand since 1978

- ✓ Zero add-on chemicals, total zero pollution, lowest OPEX.
- ✓ 20 melamine units licensed across four continents, 14 licensees the likes of QAFCO, MHTL, Grupa Azoty, Petrochina.
- ✓ Two new world-scale melamine plants under commissioning in 2016, including the world's largest single-reactor HP melamine plant.

Euromel[®] brand is registered in 48 countries representing 85% of the melamine world's consumption. Euromel[®] melamine is top quality only.

**MAKING
SUSTAINABILITY
PROFITABLE**



CONTENTS

What's in issue 341

COVER FEATURE 1

Long-term fertilizer demand

COVER FEATURE 2

Challenges for India

COVER FEATURE 3

Sulphur-enhanced urea

COVER FEATURE 4

Optimising catalytic reactors

NITROGEN+SYNGAS
ISSUE 341
MAY-JUNE 2016

BCInsight

Southbank House, Black Prince Road
London SE1 7SJ, England
Tel: +44 (0)20 7793 2567
Fax: +44 (0)20 7793 2577
Web: www.bcinsight.com
www.bcinsightsearch.com

Price trends



MARKET INSIGHT

Laura Cross, Senior Analyst, Integer Research, assesses price trends and the market outlook for nitrogen.

NITROGEN

Weak prices dominated the nitrogen market during the opening months of 2016, with chronic oversupply remaining the main influence. This weakness has been further compounded by sluggish demand across Europe – with the exception of Turkey – and Latin America, while major urea buyer India only came back to the market in late-April. The key nitrogen price benchmarks have fallen below five-year lows, with the urea market in particular feeling the strain of weak market sentiment and buyers holding off in anticipation of further price cuts. However, more robust demand prospects are on the horizon in some key importing regions and seasonal buying is expected to support market sentiment until May and June. Indian urea stocks were comfortable in Q1 but expectations were that sizeable purchase tenders would be issued from April in line with the country's new financial year. In the US and Europe, demand has been firm amid spring plantings and buying is expected to continue in the coming months as application levels increase once the weather allows farmers to begin field work.

Global ammonia prices continued to decline in January but the supply/demand balance narrowed in late-February and March due to emerging seasonal demand in the US

and Europe and the prospect of tight supply from key export regions. In a bid to halt prices from falling further, producers mainly focused their efforts on domestic markets, and restricted supply through scheduled turnarounds. After crashing to a decade low in January, urea prices stabilised, with an uptick in some regions in February. This increase came slightly earlier than expected, on the back of strong demand in the US and supply outages in North Africa. On the supply side, Egyptian producers resumed production after all four exporters were down in mid-February due to gas supply constraints.

The fundamentals for ammonia prices look reasonable. Although international crop prices are relatively weak, US corn area is predicted to be among the highest on record, and this should support ammonia demand through the delayed spring application season. Black Sea availability is also expected to remain constrained with lower supplies from OPZ. In addition, increased natural gas curtailments in Trinidad which first started in mid-February are expected to continue to hinder ammonia operations. In Egypt, all producers operated at around 70% capacity for the first two weeks of April, down from an average of 85% in March due to gas supply restrictions.

Urea prices remained under pressure in March as demand was slower than expected.

Cold and wet weather delayed the spring application season in the US, leading to a weaker NOLA market. A pickup in domestic demand in China meant producers held firm on export prices in late March, though stock levels at Chinese ports remained in excess of one million tonnes at the end of month. Some delays in purchasing outside the US are expected while buyers digest the recent price increases, though India returned to the market with a tender for an undisclosed volume at the end of April. Supply from Yuzhny producers was limited in April with all production from Ostchem's plants committed to the domestic market with no export availability. After spring demand subsides through May and June, we might see downward price pressure once again.

The Chinese coal price decline was the primary contributor to the downward shift in the international floor price for urea over the past year. In 2015, new Chinese urea capacity continued to come on stream, even though urea has been in oversupply in China for some time. The emergence of many new plants relying on competitively priced feedstock and showing high energy efficiency, and the Chinese government liberalising its urea export policy, has led to additional urea capacity becoming competitive in international markets. In China, coal-based urea capacity represents more than 70% of the total and the remainder is gas-based. Anthracite is the most widely utilised feedstock for urea production, and although prices have seen a downward spiral in the last three years, between 2008 and 2012 anthracite coal prices increased rapidly. By comparison, the price of other types of coal, such as lignite and bituminous coal have been much lower, sometimes 30% below anthracite prices. As a result, additional bituminous coal-based urea plants were built, and some large-scale anthracite based urea producers also started to upgrade their technology so that they could use alternative types of coal. In the first quarter of 2016, bituminous coal prices for some Chinese urea producers were assessed as low as US\$1.50/MMBtu. Integer's analysis of the Chinese urea market has revealed that about 75% of total urea capacity can operate at production costs below \$200 per tonne. China has become increasingly influential in international markets along with the improvement in its competitiveness on the export stage, but the question now remains as to whether coal prices in China have hit a floor and whether there is room for Chinese coal-based urea producers to lower costs further.

END OF MONTH SPOT PRICES

natural gas

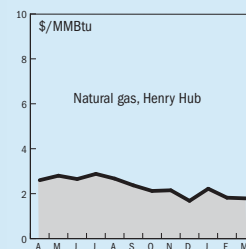

ammonia

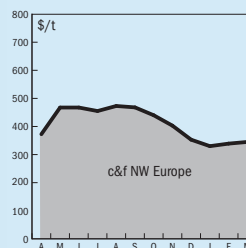

urea

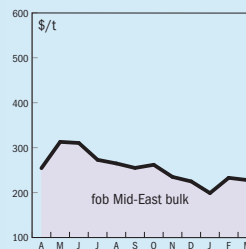

diammonium phosphate

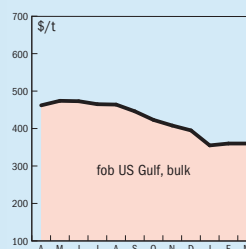

MARKET INSIGHT

Mike Nash, Global Business Director, IHS Chemical, assesses the market for methanol.

METHANOL

In the US, the April contract gas reference price was settled at \$1.84/MMBtu for Texas, and \$1.99/MMBtu for Louisiana, up \$0.20/MMBtu from March. US spot methanol market activity was thin the final week of April. Both Southern Chemical and Methanex posted their contract prices for May at \$0.75/gallon with the spot bid/offer level at \$0.63-0.67/gallon. The large gap between contract and spot prices that has been present in the US market since the start of the year has now collapsed back towards historical trends. US methanol demand continues to see modest gains in construction applications, particularly coatings. Biodiesel demand remains steady with a clear picture on RFS blend levels and a tax incentive in place for the year. Production is lower, with OCI Beaumont experiencing a cooling tower line failure April 20th that necessitated the unit being taken down. In South America, Venezuelan units are understood to be running at 80-85% of nameplate capacity, Methanex's Chilean unit at an estimated 40% of capacity. May deals were thin with one \$0.65/gallon deal possibly transacting, but the US price is still trending upward.

European prices rose due to stronger sentiment and high operating rates at MTO facilities in China. Inventories in Northwest Europe are reducing due to improved selling interest and outages in the Mediterranean. Demand into MTBE is increasing. EMethanex in Egypt is idled and is unlikely to restart before the summer peak gas demand period. Both lines at Sirte Oil in Libya remain closed after maintenance to repair a technical issue with a gas turbine. Trade data shows that 205,000 tonnes was loaded from the US and shipped to Western Europe in January and February, equivalent to around two thirds of the total volume shipped in 2015, but there are signs that inventories are beginning to reduce and a rise in global methanol prices has prompted some profit taking with vendors starting to sell spot tons out of storage. Offers for f.o.b. T2 Rotterdam material were generally above €200 per metric ton. Supply in the Mediterranean has become more restricted; political risk

remains high in North African countries and issues with gas supply persist. Algerian production is stable but ethanol content in methanol produced at this plant is occasionally an issue.

High prices in China have incentivised Middle East producers, such as Qatar and Oman, to export methanol east, rather than bring product to Europe. In the long term, the rapid growth in MTO capacity will also necessitate exports from the US to China. IHS Chemical is forecasting a slow but steady increase in European methanol prices over 2016, with Europe at a consistent premium to the US in order to incentivise imports from this region, as China becomes more interesting for Middle Eastern producers. In addition, global operating rates will need to increase to meet the demand into MTO and energy-related applications, which will require higher cost producers to come onstream – leading to an increase in global methanol prices.

The Chinese market is running normally with a reasonable number of spot deals concluded. Buying sentiment is stable-to-strong especially in South China due to tight supply in the region. An unexpected outage of the major Petronas unit in Southeast Asia put pressure on the supply in South China. Deals focused on formula prices rather than fixed prices since there was a visible gap between buyers and sellers. Chinese methanol demand is stable at a healthy level. Demand into acetic acid picked up with an increase in the operating rate. Demand into DME is flat, but the DME price increased.

Spot supply continued to be tight in Asia outside China. Major suppliers looked for cargoes to satisfy their contracts. Asian spot prices are posted in a narrow range of \$223-238/t c.fr.

The latest data show that in March Chinese methanol imports were up to 628,000 tonnes, a 240% increase on February. About 200,000 tonnes of this came from Iran, a similar level to February. New Zealand continues to increase its methanol import volume to China and was in second place, with 129,000 tonnes. China also imported nearly 100,000 tonnes from South America and North America combined.

Table 1: Price indications

Cash equivalent	mid-Mar	mid-Jan	mid-Nov	mid-Sept
Ammonia (\$/t)				
f.o.b. Caribbean	270	270	360	405
f.o.b. Arab Gulf	320-340	308-323	390-425	420-450
c.fr N.W. Europe	325-355	348	410-445	474
c.fr India	340-388	368	440-470	463
Urea (\$/t)				
f.o.b. bulk Black Sea	200-204	220	258-263	255
f.o.b. bulk Arab Gulf*	230-265	201-211	255-263	266
f.o.b. bulk Caribbean (granular)	210-220	221	250-255	264
f.o.b. bagged China	200-205	222	252-255	263
DAP (\$/t)				
f.o.b. bulk US Gulf	360	395	410	458
UAN (€/tonne)				
f.o.t. ex-tank Rouen, 30%N	175-180	175	183-186	186

Notes: n.a. price not available at time of going to press
n.m. no market * high-end granular

Source: Fertilizer Week

Market outlook

Historical price trends \$/tonne

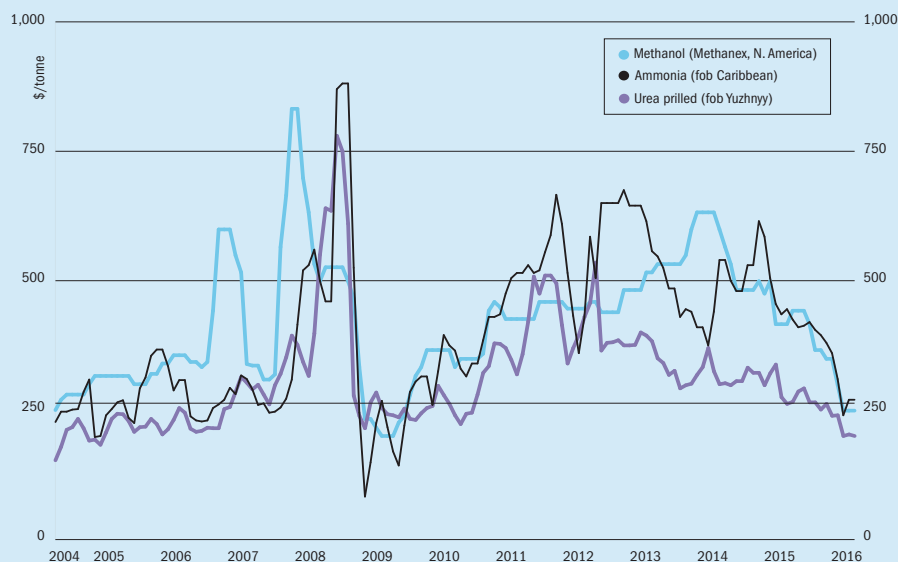

Source: BCInsight

AMMONIA

- Limited ammonia supply from Black Sea exporters is expected to continue in May. OPZ continues to run only one of its two ammonia lines and is not expected to restart the second unit until June at the earliest.
- Petronas Chemicals Group has reported that its Sabah Ammonia Urea (Samur) ammonia and urea plant in Malaysia is close to completion and is expected to begin commercial operations in H2 2016. The plant is expected to produce 150,000 tonnes of ammonia in Q4 2016.
- The supply-demand balance is expected to tighten in North America in late May/June with an expectation of stronger demand in the planting period and lower inventories expected in Trinidad amid increased feedstock cuts.
- Looking towards the longer term however several new plants with excess ammonia capacity are expected to start up this year in the US.

www.nitrogenandsyngas.com

UREA

- Global urea demand remained muted going into May as the market awaited the outcome of the MMTC Indian urea tender which closed on 25 April.
- At press time around 460,000 tonnes had been preliminarily agreed, signalling the first significant urea import demand in 2016.
- Elsewhere, demand is expected to remain subdued in May although spring application demand from US is likely to provide some support to prices, while few deals have been heard in Europe so far.
- Chinese stocks were at around 900,000 tonnes in late April and urea prices were expected to trade at higher levels from Chinese producers in May due to an uptick in domestic demand.
- In the US, persistent cold weather and heavy rain has caused a significant slowdown and lag in demand for spring plantings and the Nola FOB price was expected to remain stable in May.

METHANOL

- MTO units in China are beginning to suck in supply from all over the world, displacing cargoes which might have originally gone to Europe. Demand remains strong. Chinese domestic operating rates remain relatively low, at around 55%.
- Availability from North Africa continues to be low due to gas restrictions and technical issues. This has increased prices in Europe as ample inventories fall.
- The OCI Beaumont plant in Texas has taken an unscheduled outage and this has also helped to bring up prices in the US.
- Another outage at Petronas in Malaysia is also lifting Southeast Asian markets.
- US methanol imports are down 40% this year and will decline further as new capacity comes on-stream, although now Methanex's second plant is up and running no new capacity is expected in 2016.

Nitrogen+Syngas 341 | May-June 2016

IN HARMONY WITH YOUR NEEDS

ONE SOURCE. FROM SYNGAS TO ANY FERTILIZER.

Casale acquires Borealis' technologies for Nitrates and Phosphates (formerly GPN) and completes its fertilizer portfolio.

casale.ch

FROM TECHNOLOGY TO EPC CONTRACTING

CASALE CHEMOPROJECT NITROGEN

CONTENTS

What's in issue 341

COVER FEATURE 1

Long-term fertilizer demand

COVER FEATURE 2

Challenges for India

COVER FEATURE 3

Sulphur-enhanced urea

COVER FEATURE 4

Optimising catalytic reactors

NITROGEN+SYNGAS
ISSUE 341
MAY-JUNE 2016

BCInsight

Southbank House, Black Prince Road
London SE1 7SJ, England
Tel: +44 (0)20 7793 2567
Fax: +44 (0)20 7793 2577
Web: www.bcinsight.com
www.bcinsightsearch.com

GERMANY

Shell and UFT collaborate on sulphur-enhanced urea

Shell and Uhde Fertilizer Technologies (UFT), part of thyssenkrupp Industrial Solutions, have announced a partnership to integrate UFT's fluid bed granulation technology with Shell's sulphur enhanced urea Urea-ES technology. The two companies say that they have completed successful trials using Urea-ES emulsion in UFT's fluid bed granulation pilot plant in Leuna, Germany. Urea-ES aims to provide vital sulphur nutrient to soils by incorporating elemental sulphur into the world's most commonly used fertiliser, urea, helping to unlock higher crop yields and improved soil health. The new partnership aims to allow the largest urea plants in the world to produce granulated sulphur-containing urea.

"Fertiliser producers had been asking us about incorporating sulphur into their urea for a long time," said Matthias Potthoff, Director of Uhde Fertilizer Technologies. "From the first discussions with Shell Thiogro about a partnership, it was clear this would be a win-win relationship."

Urea-ES technology uses Shell patented technology to emulsify micron-sized particles of elemental sulphur evenly throughout urea, forming a homogeneous emulsion, in contrast to existing elemental sulphur-containing urea technologies, which typically

coat urea in a layer of elemental sulphur. The microscopic size of the sulphur particles, at under 40 micrometres (µm), promotes the oxidation of the sulphur within the crop season. The elemental sulphur liquor is finely dispersed in the urea melt before the solution is fed to the granulator. The flexibility of the UFT granulation process allows the production of Urea-ES without any significant changes; as in the normal urea granulation, the particles grow through the solidification of tiny droplets on the seed material. The result is a very hard granule, which UFT says is superior in quality to granules produced through layering or agglomeration-based processes. This slow accretion process is unique in permitting the water present in the urea solution to be thoroughly stripped on a continuous basis, resulting in the end product having a low moisture content. The bulk of the crystallisation heat released as the Urea-ES solidifies is removed by evaporating the water in the urea solution. This method of heat release reduces the amount of ambient air required for cooling and the evaporation is highly efficient because it takes place directly on the granule surface. ■

A fuller discussion of this technology can be found on pages 32-38.

NIGERIA

Indorama urea complex enters commissioning phase

The new Indorama ammonia-urea complex at Eleme Port Harcourt in Nigeria is now entering its commissioning phase, according to the company, following pre-commissioning activities in critical plant sections such as the primary and secondary reformers, granulation and materials handling sections. The facility, including a 2,300 t/d ammonia and 4,000 t/d urea plant, has been built at a cost of \$1.4 billion over the preceding 32 months. Indorama Eleme Fertilizer and Chemicals Ltd and its sister company Indorama Eleme Petrochemicals Ltd, which has built a polyethylene plant next door, are also partnering with OIS to build a new world-class port terminal complex at nearby Onne, at a cost of \$130 million. Mechanical completion of the port was scheduled for December 2015 with commissioning expected by 1Q 2016.

At 1.4 million t/a, Indorama will be able to more than satisfy Nigeria's demand for nitrogen fertilizers, and will be exporting around 1 million t/a. However, there is room for growth in the domestic market – Nigeria's fertilizer use averages only around 20 kg nutrient per hectare, as compared to 100 kg/ha in other African coun-

tries like South Africa and Egypt. Speaking to local press, the managing director of Indorama Nigeria, Manish Mundra, said that the company's next logical step is production of complex NPK fertilizers, and that they have recently acquired ICS, the Senegalese company which is the only producer of phosphates in West Africa. Currently Senegal exports its phosphoric acid to India under contract with Ifco, but Indorama hopes to divert 100-150,000 t/a of the plant's annual output of 500,000 t/a to Nigeria to produce NPKs, in combination with imported potash.

Nigeria's other nitrogen producer is Notore Chemical Industries Plc, with 300,000 t/a of ammonia and 500,000 t/a of urea capacity, at Onne. The firm operates a 1980s vintage plant originally owned by the National Fertilizer Company of Nigeria (NAFCON) which closed down in 1999 but re-opened after re-conditioning in 2010.

IRAN

Gas agreement signals progress on ammonia-urea JV

India and Iran's petroleum ministers have committed to agreeing development, financial and commercial terms to develop the Farzad B gas field off the Iranian coast by October 2016. The field's development will be led by India's state-owned ONGC Videsh. The Farzad-B field, estimated to

have 21.7 trillion cubic feet (tcf) of gas reserves, was discovered by ONGC in 2012, but international sanctions on Iran prevented signing of a development agreement. It forms part of the Farsi oil and gas field, which the National Iranian Oil Company has been working on since 2002 in conjunction with Indian partners ONGC, the Indian Oil Company and Oil India.

The gas from Farzad-B would form the feed for the proposed joint venture Indiranian ammonia-urea plant under development at the Chabahar Free Trade Zone, with long-term offtake of urea to India. Indian companies are in the process of identifying a suitable Iranian company as the joint venture partner.

NETHERLANDS

Stone laying ceremony for new granulation plant

The ceremony for the first stone laying of Yara's new urea granulation plant was held in March at Sluiskil, near Terneuzen. Yara, the world's largest producer of nitrogen fertilizers, is replacing the old prilling unit at Sluiskil with a new granulation unit which will also be able to produce sulphur enhanced urea. Urea forming capacity is increasing from 400,000 t/a to 660,000 t/a, while UAN production will fall by a similar amount, the spare ammonium nitrate being used to boost CAN produc-



Ground breaking ceremony at Yara's Sluiskil plant.

tion instead. The plant will use proprietary technology developed and owned by Yara, and will be executed by an integrated team of engineers from Yara and Maire Tecnimont.

The stone laying event, held at the Sluiskil site, which has been operational since 1929, was attended by Henk Kamp, the Dutch Minister of Economic Affairs, Petter Østbø, Senior VP and Head of Production of Yara, Fabrizio Di Amato, Chairman of Maire Tecnimont, Pierroberto Folgiero, CEO of Maire Tecnimont, Jan Lonink, Mayor of Terneuzen, as well as other institutions and industry representatives.

"We are glad to be part of such an important project both for Yara and the local community of Terneuzen," said Fabrizio Di Amato, Chairman of Maire Tecnimont, who also noted that the Sluiskil site has symbolic value to Tecnimont, as its predecessor the Montecatini Group carried out its activities in the Netherlands at the very same site during the 1960s and 70s.

UNITED STATES

Ground broken on small-scale ammonia plant

Fortigen LLC, a subsidiary of Nebraska-based property developers Tetrad Property Group, have broken ground on a \$75 million ammonia plant at Geneva, Nebraska, 70 miles SW of the state capital Lincoln.

The small-scale 90 t/d (30,000 t/a) unit will supply ammonia to local farmers in the state. Tetrad is involved in various developments within the state, including the Innovation Campus at Lincoln, but while the company says that it likes agricultural investments, this will be its first venture into chemicals. Construction on what is likely to be the smallest commercial ammonia plant in the US will start this quarter and the aim is to complete it by 3Q 2017, according to Tetrad.

CF Industries starts up new urea ammonia nitrate plant

CF Industries said its new urea ammonium nitrate (UAN) plant in Donaldsonville, Louisiana, began production in early March, and has achieved "consistent, stable operation". The Donaldsonville Nitrogen Complex is the second new plant to be commissioned and started as part of CF's major capacity expansion projects in North America. The new plant will be the

43 YEARS' EXPERIENCE IN AIR POLLUTION CONTROL

KIMRE™ SXF CROSS FLOW SCRUBBER

- Highest comparable collection efficiency
- Operation at highest gas velocities
- Any size and configuration
- Excellent fouling resistance
- Cleanable & reusable media
- Extended service life for harsh service

CONTENTS

What's in issue 341

COVER FEATURE 1

Long-term fertilizer demand

COVER FEATURE 2

Challenges for India

COVER FEATURE 3

Sulphur-enhanced urea

COVER FEATURE 4

Optimising catalytic reactors

NITROGEN+SYNGAS
ISSUE 341
MAY-JUNE 2016

BCInsight

Southbank House, Black Prince Road
London SE1 7SJ, England
Tel: +44 (0)20 7793 2567
Fax: +44 (0)20 7793 2577
Web: www.bcinsight.com
www.bcinsightsearch.com

largest operating single-train UAN plant in the world, and will make Donaldsonville the largest nitrogen facility in the world, according to CF Industries. Total annual UAN capacity at Donaldsonville is now 4.2 million t/a, up from 2.4 million t/a. Donaldsonville will also have the ability to switch its production mix between granular urea, UAN and Diesel Exhaust Fluid (DEF) based on market conditions.

"The finish line for our Donaldsonville capacity expansion project is now in sight," said Tony Will, president and chief executive officer, CF Industries Holdings, Inc. "The new UAN and granular urea plants are running consistently at or above nameplate capacities, and the new ammonia plant is within a few weeks of being mechanically complete."

CVR completes purchase of Rentech

CVR Partners says that it has completed its acquisition of Rentech Nitrogen Partners, including Rentech's East Dubuque, Illinois, nitrogen plant. CVR Partners operates a nitrogen complex at Coffeyville, Kansas based on generating ammonia from gasification of petroleum coke from a nearby refinery, and has a 1,300 t/d ammonia plant and a 3,000 t/d urea ammonium nitrate plant. The East Dubuque, Illinois facility includes a 1,025 t/d gas-based ammonia plant and 1,100 t/d UAN facility. In 2015, the Coffeyville plant produced 385,400 tonnes of ammonia and 928,600 tonnes of UAN, and the East Dubuque plant produced 340,300 tonnes of ammonia and 279,000 tonnes of UAN.

"The addition of East Dubuque to CVR Partners positions us as an emerging leader in the North American nitrogen fertilizer industry and makes us more competitive in a changing market environment," said Mark Pytosh, CEO of CVR. "CVR Partners is now better equipped to weather cyclical downturns, excel in dynamic market conditions and act on growth opportunities. We expect the enhanced strategic platform of the combined business will create value for our unit holders, customers and employees."

AUSTRALIA

Pilbara AN plant begins commissioning

Yara's new explosive/technical grade ammonium nitrate (AN) plant at Pilbara on the Burrup Peninsula in Western Australia is now in "wet commissioning" according to Yara. The 350,000 t/a plant, jointly owned by Yara and Orica and operated by Yara as

Yara Pilbara Nitrates, will convert ammonia from the 850,000 t/a Burrup Ammonia Plant, itself now under 100% Yara control after developer and joint owner Pankaj Oswal was forced to relinquish his holding in 2012, and after Yara bought out gas supplier Apache's share of the plant in 2015. Offtake from the AN plant will be marketed by Orica to mining concerns in the region.

BANGLADESH

Kafco faces seasonal shutdown again

The Karnaphuli Fertiliser Co. (Kafco) faces another seasonal shutdown from April as the plant's natural gas supply is diverted to power production. Kafco has 3,700 t/d of urea production, and also supplies excess ammonia to diammonium phosphate production at Chittagong. State oil and gas company Petrobangla says that it will stop gas supplies to all of Bangladesh's fertilizer producers apart from the Shahjalal Fertilizer Factory and the Jamuna Fertilizer Co. Last year, Kafco was shut from March 15th. Bangladesh faces higher power demand during its hot summer and lower output from hydroelectric plants.

INDIA

Toyo wins Chambal contract

Toyo Engineering has been awarded a \$625 million turnkey contract from Chambal Fertilizers and Chemicals to build a new urea plant in the northern Indian state of Rajasthan. The facility will have a capacity of 4,000 t/d of urea, making it one of the world's largest single stream fertilizer plants. The projected on-stream date is 2019 for the facility, which is part of India's plan to boost its self-sufficiency in urea to stabilise agricultural output for continued economic growth. This will be the first time a large grassroots plant has been built in India for 20 years.

Toyo has its own patented technology for urea production. It first entered the Indian market in 1963 and so far has built 14 fertilizer plants in the country.

Ammonia supply disruption at Haldia

Tata Chemicals Ltd (TCL) has signed a memorandum of understanding with Sanjana Cryogenics Storage Ltd (SCSL), its ammonia terminal operator, to re-route a section of the ammonia pipeline that runs from Haldia dock to the company's ammonia storage tank. Tata says that the move is a directive of the Kolkata Port Trust in

order to facilitate the setting up "a multimodal terminal hub" at Haldia by the Inland Waterways Authority of India. The company says that the pipeline re-routing activity is likely to cause a five week temporary shutdown of operations at Tata's phosphate fertilizer plant at Haldia during September and October 2016 due to the interruption of ammonia supply to the facility, which produces di-ammonium phosphate (DAP), single superphosphate (SSP) and complex NPK fertilisers, with a combined capacity of over 1.2 million t/a.

Plans firming on urea expansions

Following a meeting between the Prime Minister, Fertiliser Minister Ananth Kumar, Oil Minister Dharmendra Pradhan and Power & Coal Minister Piyush Goyal, plans for new urea production in India seem to be firming, although availability of natural gas remains the key issue. State gas utility Gas Association of India Ltd (GAIL) has been told to expedite construction of the new pipeline from Jagdishpur in Uttar Pradesh to Haldia in West Bengal to provide connectivity to the idled urea plants at Gorakhpur in Uttar Pradesh, Barauni in Bihar and Sindri in Jharkhand. ONGC is reportedly to form a joint venture with the Hindustan Fertiliser Corporation Ltd (HFCL) for the revival of the urea plant at Barouni, while the Fertiliser Corporation of India Ltd (FCIL) will form two separate joint ventures with CIL and NTPC for the revival of the Sindri and Gorakhpur plants. Attempts to put these plants out to private tender last year drew a poor response.

India's urea production reached a record 24.5 million t/a in the 2015-16 financial year, but total demand of 30 million t/a means that the rest must be imported.

Coal based urea plant proposal

Chemicals and Fertiliser Minister Ananth Kumar recently reaffirmed that the government is still pursuing a coal gasification based urea plant in Chhattisgarh state in the east of the country – the \$900 million plant would have 1.3 million t/a of urea capacity as part of a \$3.8 billion development unveiled in August last year by Adani group, including coal to synthetic natural gas (SNG). It is one of ten proposed coal-based fertilizer plants which were announced last year.

However, progress at the Talcher site in Odisha state continues to be slow. Air Liquide's Lurgi gasification technology will now be trialled at a pilot unit at Jindal Steel and Power's Angul direct reduced iron facility to

see if it can handle the high ash coal from the region – the company is now the preferred bidder to supply the gasification technology for the plant. However, a recent critical report by SBI Capital Markets cast doubt on the economic and technical feasibility of the project.

AZERBAIJAN

SOCAR start-up scheduled for 2018

The State Oil Company of Azerbaijan Republic (SOCAR) says that it is aiming for plant start-up on its new ammonia-urea plant in the first quarter of 2018. The plant, which is being constructed by Korea's Samsung Engineering, is reportedly 66% complete. Annual production of 660,000 t/a of urea will be split, with around 150-200,000 t/a going to supply the local market, and the remaining two thirds exported, with Turkey the main target market. Turkey currently imports 1.5 – 1.8 million t/a of urea, from Russia, Ukraine and the Middle East. The total cost of the plant will be €920 million. The EXIM Bank of Korea is said to be in discussions about a long-term loan facility to the company for completion of construction work, with the Republic of

Azerbaijan guaranteeing the loan. Payback is estimated at 8 years.

MALAYSIA

Samur to come on stream in 2H 2016

Petronas has reported that the Samur project is "98% completed" and is expected to be operational in the second half of the year. When operational, the new facility will have a capacity of 1.2 million t/a of urea. Petronas says that it expects to produce 150,000 tonnes of urea from Samur in 4Q 2016, and that it is looking to run the plant at 70-75% capacity in 2017, ramping up to full production by the end of the year. Petronas indicated that the bulk of its \$1 billion capex budget for 2016 would go on Samur and the new RAPID complex at Pengerang.

ITALY

Tecnimont earnings up for 2015

The Maire Tecnimont Group has published its accounts for 2015. Total revenues for the group were €1.67 billion, up 5.5% on 2014, reflecting progress on ongoing projects and several newly awarded projects

in the Technology, Engineering and Construction business unit, according to the company's board. Operating profit for the group was €211 million with a margin of 12.7%, down 0.6% on 2014. The largest division of the company is its Technology, Engineering & Construction unit, which accounted for €1.55 billion of group revenues, and earnings before income, tax, deductions and allowances of €133 million. New orders during the year include contracts from Adgas in Abu Dhabi, Grupa Lotos in Poland, Yara in the Netherlands, SOCAR in Azerbaijan, and EuroChem and JSC Gazprom Neft in Russia. ■

Correction

Two errors crept into our Nitrogen Project Listing in the previous issue (Nitrogen+Syngas 340, March/April 2016, pp28-31). Under Slovakia, the new ammonia plant is being constructed by Technip, not Chemoprojekt. Under Vietnam, the ammonia plant licensor should be Haldor Topsoe, and not thyssenkrupp. We apologise to the companies involved for the errors.



Schoeller-Bleckmann Nitec, Hauptstrasse 2, A-2630 Ternitz, P: +43/2630/319-0, F: +43/2630/319-19, E: sbn@christof-group.com, I: www.christof-group.com



How to save time & money

Even the best equipment is subject to wear and tear, and that means expensive plant turnarounds. As a leading high-pressure vessel manufacturer in the nitrogen sector, we can save you time and money by performing the maintenance and in situ repair of your heat exchangers and reactors in the shortest possible time. And we can provide replacements, seeing to everything from design to installation.

We have all the know-how to work with all the materials involved – and a strong international track record of successful reference projects. Our highly skilled task force have already completed a large number of in situ works abroad.

So why not ask our specialists to advise you on your next in situ project?

CONTENTS

What's in issue 341

COVER FEATURE 1

Long-term fertilizer demand

COVER FEATURE 2

Challenges for India

COVER FEATURE 3

Sulphur-enhanced urea

COVER FEATURE 4

Optimising catalytic reactors

NITROGEN+SYNGAS ISSUE 341

MAY-JUNE 2016

BCInsight

Southbank House, Black Prince Road
London SE1 7SJ, England

Tel: +44 (0)20 7793 2567

Fax: +44 (0)20 7793 2577

Web: www.bcinsight.com
www.bcinsightsearch.com

UNITED STATES

Primus to build modular methanol plant

Modular GTL technology company Primus Green Energy Inc. says that it plans to develop a 160 tonne/day methanol plant at a site in the Marcellus shale region. Production from the plant is slated to begin in 2017 for regional distribution, with three additional trains in subsequent years expected to increase its capacity to a final total of 640 t/d.

The company is using a version of its STG+ (Syngas to Gasoline Plus) technology for the plant. STG+ is essentially a multi-step reaction from steam reforming to methanol production, dimethyl ether (DME) production, and then a DME to gasoline conversion and purification step. This plant will obviously omit the later steps and focus instead on methanol production. Primus says that the low-cost Marcellus shale gas combined with its modular technology means that the plant will be cost-competitive with a world-class methanol plant located on the US Gulf Coast and in international markets for supplying local users in the northeastern states. The company says it plans to deliver

up to four additional methanol plants in other North American regional markets with capacities ranging from 160 t/d to 640 t/d using the same standardised design.

Sam Golan, chief executive officer of Primus Green Energy said: "in North America specifically, our technology offers clients a politically-stable, cost-effective avenue for local methanol and gasoline production, and we look forward to continuing to provide the industry with this domestic solution."

Primus' STG+™ technology can use a range of natural gas feedstocks, including wellhead and pipeline gas, dry or wet associated gas, 'stranded' ethane, excess syngas from underutilised reformers or mixed natural gas liquids. The systems' stranded and associated gas applications offer an ideal solution to the lack of traditional natural gas pipeline infrastructure in remote locations, enabling the monetisation of gas that would otherwise be stranded or flared. The low-cost, modular systems can be trucked in and assembled on-site for easy deployment. ■

Yet more delays for coal gasification plant

The Kemper County integrated gasification combined cycle (IGCC) power plant in Mississippi is facing further delays and cost overruns according to a recent filing by developer Southern Co. with the US Securities and Exchange Commission (SEC). The filing indicates an extra \$18 million in additional expenses – a small increment compared to the \$6.6 billion that the project has cost so far – is reportedly "related to operational readiness and challenges in start-up and commissioning activities which includes the cost of repairs and modification to the refractory lining inside the gasifiers." Another \$110 million has been added by the delay in start-up to August 31, which puts the project roughly three times over its initial budget and three years behind schedule. The fall in global oil and gas prices has rendered the point of a coal-based system largely moot, and most similar such projects have been cancelled.

G2X buys into Beaumont methanol project

Houston-based G2X Energy Inc. says that it is paying \$680 million, including a \$50 million loan, to buy a 50% stake in the Natgasoline methanol project in Texas from developer OCI NV, which also owns an existing ammonia/methanol plant at Beaumont. The new plant is expected to produce

1.75 million t/a of methanol when it comes on-stream in late 2017. G2X is a subsidiary of Consolidated Energy Ltd, which is the world's second-largest methanol producer, with several plants on Trinidad, and part owned by the German/Swiss Proman Group and Germany's Helm AG. G2X is also developing its own \$1.6 billion Big Lake Fuels methanol plant in Lake Charles, Louisiana, and broke ground in January this year, but may look to delay that project now, using the Beaumont plant as its way into the market instead. Consolidated Energy will handle methanol offtake, sales and distribution from the new Beaumont plant, and G2X and Proman will contribute management and technical personnel.

CHINA

Global agreement on methanol-fuelled trucks

FItech has concluded an agreement with Beiben Heavy-Duty Trucks of Baotou, Inner Mongolia, for the production of methanol-fuelled, heavy-duty trucks based on Beiben's popular V3 model, originally designed and built in a joint venture with Daimler-Benz. The trucks will be available worldwide based on a modified Weichai engine designed by FItech which the company says requires no additional reconfiguration of the original V3 chassis. FItech has exclusive global distribution rights for the Beiben methanol model with the first truck expected to roll off the assembly line in August, 2016.

SES signs agreement for 20 gasification projects

Synthesis Energy Systems has announced a strategic Joint Project Development and Investment Agreement with the China Environment State Investment Co., Ltd (CESI). CESI is a state-owned enterprise operated by the Chinese Ministry of Environmental Protection charged with developing and investing in the energy conservation and environmental protection industry. SES and CESI have agreed to develop, jointly invest, and build a total of at least 20 projects using SES gasification technology over the next five years, and are aiming to bring at least two projects through development within 12 months. Equity in the projects is expected to be owned 51% CESI, and 49% SES through SES's wholly owned Hong Kong subsidiary, SES Clean Energy Investment Holdings Ltd. SES says that this is the first of several equity participation collaborations it is working on with governments and leading companies in China and internationally.

SES and CESI have identified a pipeline of potential projects and intend to focus initially on four target projects: an industrial fuel syngas project in Inner Mongolia for an industrial park, which is intended to be further expanded in Phase 2 to provide compressed natural gas (CNG) and liquefied natural gas (LNG) for transportation fuels; an industrial hydrogen and fuel syngas project in Shandong Province; and two industrial park syngas projects, in Shandong and

Hebei provinces. The projects vary in size and the estimated total installed costs of the four projects range between \$75 million to over \$400 million per project.

"We are excited to be working with the China Environment State Investment Company and its dynamic and forward-looking Chairman Wang Wei, and to become an integral part of the Chinese government's mandate to develop and invest in energy conservation and environmental protection. We look forward to working together on this groundbreaking and far-ranging joint venture, to help China achieve its clean energy goals," said Lorenzo Lamadrid, SES Chairman of the Board.

Air Liquide strengthens Chinese partnership

Air Liquide has signed a new long-term contract with Maoming Petrochemical Co. (MPCC), a subsidiary of China Petroleum & Chemical Corp. (Sinopec). Under the terms of the new agreement, Air Liquide will invest around 40 million euros in a new state-of-the-art ASU (Air Separation Unit), with a total capacity of 850 t/d of oxygen. Expected to start operations in the second quarter of 2017, the new ASU will supply industrial gases including oxygen and nitrogen to the customer's new ethylene oxide plant as well as an existing one. The ASU, located in Maoming City of Guangdong Province, will be designed and supplied by Air Liquide's Engineering and Construction teams using leading technologies to offer energy efficiency as well as optimal reliability and safety. It will be owned and operated by ALMPCC, the joint venture of Air Liquide China and MPCC established in June 2012.

RUSSIA

MHI to build ammonia-methanol plant

A memorandum of understanding to build a second ammonia-methanol complex in the Russian republic of Tatarstan was signed in Tokyo between investor JSC Ammoni and Japanese firms Mitsubishi Heavy Industries (MHI) and Sojitz Corp. in the presence of the president of Tatarstan Rustam Minnikhanov. Ammoni is a joint venture between Regiongazfinans and the Tatarstan government. The first complex, also supplied by MHI and Sojitz, was commissioned last year. It is based in the town of Mendelejevsk and is designed to produce 717,500 t/a of ammonia alone or 455,000 t/a of ammonia and 238,000 t/a of methanol. It also includes a downstream urea plant.

Minnikhanov said during the signing that the existing facility is the result of a unique cooperation between Russia and Japan and now is the time to build a similar complex and use the existing documentation and experience gained during the construction of the first complex. This will reduce the costs and the development time of the new project. The original project cost \$1.4 billion.

AUSTRALIA

Linc Energy goes into administration

In a sign of the difficult times for underground coal gasification (UCG) in Australia, UCG pioneer Linc Energy has gone into voluntary administration in Australia. PPB Advisory will be the new administrators, and the company has been de-listed from the Australian Securities Exchange, although it remains on Singaporean and US exchanges. The company faces \$56 million in fines relating to its experimental UCG pilot project at Chinchilla

in Queensland, relating to alleged contamination of groundwater – something the company continues to dispute. There are also charges of exposure of workers to syngas releases between 2007-13.

The company continues to operate UCG prospects in Uzbekistan and Poland.

CANADA

Methanol ships go into service

As from April, Methanex subsidiary Waterfront Shipping Co Ltd. will place its first 50,000 dwt vessels into service equipped with new dual fuel engines which can run on methanol, fuel oil, marine diesel oil or gas oil. With the growing demand for cleaner marine fuel, Methanex believes methanol is a promising alternative fuel to meet the industry's increasingly stringent emissions regulations.

Waterfront Shipping will charter the seven vessels to replace older vessels and expand its fleet. Two of the vessels are owned by Westfal-Larsen Management (WL), two are jointly owned by Marinvest and Waterfront, and the remaining three vessels are owned by Mitsui OSK Lines Ltd. The ships were built by Hyundai Mipo Dockyard and Minaminippon Shipbuilding Co., Ltd. The first three vessels are being delivered in April, with the remaining four to be delivered by October 2016.

"The cost to build new and convert existing vessels to run on methanol is significantly less than alternate fuel conversions," said Jone Hognestad, president of Waterfront Shipping. ■



Distribution at:
AICHe Ammonia Safety Symposium,
Denver, Colorado

Features in the July/August issue:

- Ammonia industry incidents
- Reformer furnace revamps
- Issues with ammonia transportation
- Iran and the Gulf
- Feedstock economics

CONTENTS

What's in issue 341

COVER FEATURE 1

Long-term fertilizer demand

COVER FEATURE 2

Challenges for India

COVER FEATURE 3

Sulphur-enhanced urea

COVER FEATURE 4

Optimising catalytic reactors

NITROGEN+SYNGAS
ISSUE 341
 MAY-JUNE 2016

BCInsight

Southbank House, Black Prince Road
 London SE1 7SJ, England
 Tel: +44 (0)20 7793 2567
 Fax: +44 (0)20 7793 2577
 Web: www.bcinsight.com
 www.bcinsightsearch.com

People

Abhey Oswal, Chairman and CEO of Oswal Greentech Ltd (formerly known as Oswal Chemical and Fertilizers Ltd), died in Moscow on March 29th of a heart attack at the age of 67. Abhey Oswal was the patriarch of the powerful Oswal family, and died without leaving a will, leaving the company open to a succession squabble among his relatives. He and his widow, **Aruna Oswal** between them owned 42% of Oswal Agro, which in turn controls 36% of Oswal Greentech, and Abhey and Aruna also owned 11% and 9% respectively of Oswal Greentech in their own right. Oswal Greentech operates the world's largest grassroots DAP plant at Paradeep in Orissa state, and an 850,000 t/a ammonia-urea plant at Shahjapur in Uttar Pradesh. The company also has a 14% stake in broadcaster NDTV. Abhey Oswal's eldest son **Pankaj Oswal** is reported to be staking his own claim to inherit the business empire, although he and his father are said to have fallen out over the 2006 Burrup Fertilizers ammonia joint venture in Western Australia. Originally a joint venture between Pankaj and Yara, Pankaj and his wife Radhika's interest was forced out after a default on a \$900 million loan from the Australian and New Zealand Bank, and questions remain over his tax and other

corporate affairs in Australia, including allegations of tax evasion and misuse of company funds for his own ends.

The board of directors of Oswal Greentech was said in Indian press reports to have nominated Aruna Oswal as the company's new chairperson.

Methanex has announced the appointment of **Benita Warmbold** to its board of directors. According to the company, Ms. Warmbold has considerable senior management experience, both financial and operational. She is currently the senior managing director and chief financial officer of the Canada Pension Plan Investment Board (CPPIB), a professional investment management organisation responsible for investing funds on behalf of the Canada Pension Plan. Prior to joining CPPIB, Ms. Warmbold was the managing director and chief financial officer for Northwater Capital Management Inc. and prior to that she held senior positions with Canada Development Investment Corporation and KPMG. Ms. Warmbold, a Canadian resident, also serves as a director of the Canadian Public Accountability Board, Queen's University Board of Trustees and Women's College Hospital.

Stephen Jacob has been appointed chief executive officer of BASIS Registra-

tion Ltd, the independent standards setting and auditing organisation for the UK's pesticide, fertiliser and allied industries. Mr Jacob joined BASIS in 2011 as Business Development Manager and was appointed Acting CEO in November after the resignation of the previous Managing Director.

BASIS Chairman Chris Clarke said: "We are delighted that Stephen has emerged from an open selection process as our new Chief Executive. The Board unanimously backed his appointment. We recognise the knowledge that he has developed within the industry as well within the charity's roles in training and certification. We look forward to working with Stephen and the senior team to develop a strategy that will ensure BASIS Registration meets the needs of its members and other key stakeholders."

Mr Jacob says: "I am delighted to have been appointed to this position. BASIS has developed into an essential organisation serving a range of sectors ranging from crop protection and nutrition through environmental pest control. In a rapidly changing world, it is vital that BASIS continues to evolve and I look forward to working with the trustees on developing strategies to take BASIS and its membership forward."

Calendar 2016

MAY

30 - June 1

84th IFA Annual Conference, MOSCOW, Russia.
Contact: IFA Conference Service
Tel: +33 1 53 93 05 00
Email: ifa@fertilizer.org

JUNE

9-10

26th IMPCA European Mini-Conference, PORTO, Portugal. Contact: IMPCA, Avenue de Tervuren 270 Tervurenlaan, 1150 Brussels, Belgium.
Tel: +32 (0) 2 741 86 83
Fax: +32 (0) 2 741 86 84
Email: info@impca.be

23-24

International Fertilizer Society Meeting, BUDAPEST, Hungary.
Contact: International Fertiliser Society
Tel: +44 1206 851819
Email: secretary@fertiliser-society.org

SEPTEMBER

18-22

AICHE Ammonia Safety Symposium, DENVER, Colorado, USA.
Contact: AIChE Customer Service
Tel: +1 800 242 4363/+1 212 591 8100
Fax: +1 212 591 8888
Email: xpress@aiiche.org

18-23

Ammonium Nitrate/Nitric Acid Conference, EINDHOVEN, Netherlands.
Contact: Hans Reuvers, BASF
Email: johannes.reuvers@basf.com
karl.hohenwarter@borealisgroup.com

OCTOBER

11-13

29th AFA Int'l. Fertilizer Technology Conference & Exhibition, TUNIS, Tunisia.
Contact: Arab Fertilizer Association, Cairo, Egypt.
Tel: +20 2 24172347
Email: info@afa.com.eg

25-27

IFA Production and International Trade and IFA Crossroads Conferences, SINGAPORE.

Contact: IFA Conference Service
Tel: +33 1 53 93 05 00
Email: ifa@fertilizer.org

NOVEMBER

7-11

IFDC Granular Fertilizer Production Workshop, BANGKOK, Thailand.
Contact: IFDC, P.O. Box 2040, Muscle Shoals, Alabama 35662, USA.
Tel: +1 256 381 6600
Email: training@ifdc.org

21-23

CRU Asia Nitrogen 2016 Conference, JAKARTA, Indonesia.
Contact: CRU Events
Chancery House, 53-64 Chancery Lane, London WC2A 1QS, UK.
Tel: +44 (0) 20 7903 2444
Fax: +44 (0) 20 7903 2172
Email: conferences@crugroup.com

Nitric acid catalysts and process plants ...

Total capability PGM recovery and refining services—from catalyst to storage tank—anywhere, anytime

It's what you'd expect from a worldwide—and world class—precious metals refining organization:

- Low pressure drop palladium recovery gauzes—design, installation, and refining
- Refining of PGMs from process gas and acid filters
- Recovery of PGMs from plant residues—storage tanks, vacuum cleanings, sweeps, etc.
- Non-destructive cleaning of plants and components using on-site PGM recovery services; refining of PGMs
- Destructive recovery of PGMs from redundant or decommissioned plant equipment

Sabin maximizes platinum recovery from the catalyst

Sabin's low pressure drop palladium recovery gauzes are custom configured to reduce down time, increase production, and minimize operating costs.



METAL CORPORATION
Nitric Acid Group
Scottsville, NY 14546 USA
Telephone: 585-538-2194

Tell us about your nitric acid processing and production applications at sabinmetal.com



CONTENTS

What's in issue 341

COVER FEATURE 1

Long-term fertilizer demand

COVER FEATURE 2

Challenges for India

COVER FEATURE 3

Sulphur-enhanced urea

COVER FEATURE 4

Optimising catalytic reactors

NITROGEN+SYNGAS
ISSUE 341
MAY-JUNE 2016

BCInsight

Southbank House, Black Prince Road
London SE1 7SJ, England
Tel: +44 (0)20 7793 2567
Fax: +44 (0)20 7793 2577
Web: www.bcinsight.com
www.bcinsightsearch.com

Plant Manager+

Problem No. 36 Change in colour of urea product

Stainless steel owes its corrosion resistance to the presence of a protective chromium oxide layer on the surface. As long as this layer remains intact, the metal corrodes at a very low rate. If the passive layer in stainless steel is damaged, active corrosion starts in aggressive corrosive environments. Stainless steels exposed to carbamate containing solutions in the urea synthesis section can be kept in a passive state by adding a minimum amount of oxygen. If the oxygen content drops below this minimum, active corrosion starts, which can be identified by a shiny silver colour on the surface (see picture). Adding oxygen and maintaining a sufficiently high oxygen content in the various process streams are prerequisites for preventing excessive corrosion of the equipment and piping. Once active corrosion occurs, the corrosion rate is extremely high (>50 mm/year) and will not stop even if more oxygen is supplied to the process.



Mr Akbar Ali from SAFCO, Saudi Arabia starts off the discussion: What are the possible causes for a change in urea product colour e.g. a dull white colour?

Mr Mark Brouwer from Ureaknowhow.com, The Netherlands, provides the first answer: I know of two causes: oil and corrosion products (iron oxides). Check the nickel content in the prills and compare it to the normal level and/or check for high oil consumption somewhere. A low level in a tank could indicate that oil is passing to the downstream sections.

Mr Nasir Hussain from Pak Arab Fertilizers Multan in Pakistan joins the discussion and provides further information based on his experiences: Oil and corrosion products are the most common causes of a change in prill colour. Another reason can be if the urea solution is held for a longer time in the urea melt storage tank. When we recycle this urea with fresh urea melt it results in a colour change. To check for corrosion products samples can be collected at the exit of the reactor, stripper, medium pressure decomposer, low pressure decomposer etc. to determine the exact location.

Mr Faisal Ghafoor from Fertil, United Arab Emirates shares his experience: The presence of methanol in the CO₂ from the ammonia plant can also cause a colour change; this can be observed with a new LTS catalyst.

Mr Sam QR from Fertco company in India confirms Mark's recommendation: As Mark said, it is mostly the corrosion product you will see after a stoppage or load reduction. Check for iron and nickel in the product.

Mr Malik Sohail from SAFCO in Saudi Arabia shares his experience: Yes the possible causes of product colour change have been provided by Mark. Of these I believe that during plant operation the causes are a high oil content from the pumps and compressor and/or an abrupt drop in the recovery level and concentration sections. This can be indicated by the level glass of the final separator. Foaming in the first stage evaporator can be seen from the level glass. When ammonia is imported from ammonia storage it is possible for it to have a high oil content.

Mr Muhammad Farooq from SAFCO in Saudi Arabia asks Akbar a question: Is this a permanent change of colour of the urea product or did you observe it during foaming or excess ammonia at the concentrator and rectifying column?

Akbar summarises and provides more information on the issue: Thank you for your inputs. We experienced this problem during a start-up after holdup of urea solution in the reactor for 48 hours. Just before shutdown we encountered a problem of increased H₂ slippage up to 1.4% (for 15 days) with CO₂ from the ammonia side; due to a problem in the ammonia plant, the delta temperature across the hydrogen reactor approached 68°C.

We suspect that during this time it was not possible to manage the air flow control properly, as seen from the oxygen content trend downstream of the hydrogen reactor. This would have resulted in active corrosion which probably caused the change in product colour. After three days of operation the original colour was resumed.

Mr Majid Mohammadian from PIDMCO in Iran shares his opinion: Contamination with impurities from the recycle tank or urea formaldehyde tank (in case of use) could be another cause.

Mr Muhammad Kashif Naseem from SABIC in Saudi Arabia gives his recommendations: From my experience, product colour can change due to the following:

- high oil contents in product;
- high iron contents;
- carry-over of CO₂ system absorbent to the synthesis loop.

Please confirm the passivated air range of between 0.6-0.8 vol-% in CO₂, which is dependent upon the N/C ratio and the material of construction of the HP synthesis system. During a colour change measure the oil, Fe and Ni content in the product at different sample points. During the hold-up time whether in the reactor or the urea solution tank, the product colour always changes during start-up.

Mr Victor Rengel from FertiNitro in Venezuela asks a new question: I would like to take advantage of this discussion to ask about the normal limits for the nickel content in urea during reliable plant

operation. In the last few days we had a plant shutdown with a delay of three days for recuperation. Yesterday after start-up we noted a yellow colour in the urea granules. We checked the nickel content, which was 4.44 ppm, much higher than the normal average of 0.02 ppm. We have stopped feeding liquid urea from the tank. We would like your opinion or advices about the high Nickel from the point of view of damage to the passivation layer or equipment corrosion.

Mark replies: In the case that your passive layer is not fully intact and as a result there is active corrosion, the active corrosion will continue even if you increase the oxygen content.

If you have active corrosion somewhere, you will see an increasing trend of your nickel level. There is no normal limit, every plant has its typical normal nickel level depending on materials used etc.

Victor provides further information: After stopping the feed from the urea liquid tank the nickel level is decreasing back to its normal value, therefore is no active corrosion.

Mr Nimesh Maurya from KRIBHCO in India shares his opinion: As mentioned earlier, the colour change of the urea prills is due to two main reasons: corrosion and oil contamination.

When oil seals of the ammonia compressor or carbon dioxide compressor leak oil into the system, it can be diagnosed by viewing the glass window of the MP urea holder and LP holder. If there is any foaming it means oil is coming into the system.

If oil is entering with liquid ammonia it can be removed by draining the ammonia receiver tank for some time. When you drain it, lumps of oil will come out. The ammonia receiver tank needs to be drained regularly until the leakage problem is solved.

Akbar comes back with more information: The intent of this post is to share our problem related to blocking in and its impact on product quality at one of our units (1,800 t/d Stamcarbon technology with fluid bed granulation). We are facing a frequent problem regarding off spec product due to its dull white colour, this is a common thing now whenever urea solution is kept under blocking in for 24 hours or even less than 24 Hrs.

During a recent shut down (April 29, 2014), urea solution was kept for about 25 hours for blocking in. After start up, for more than two days product was off spec due to a dull white colour. Regular analysis for Fe and Ni in the final product was carried out and it was found that the Fe content was very high (up to 5 ppm compared to the normal figure of <0.1 ppm), but in all samples the Ni content was < 0.1 nppm which is acceptable and normal for us.

We checked the synthesis parameters before and during blocking in as below:

- O₂ to stripper as per analyser was 0.66 vol-%;
- reactor temperature during blocking in came down to 140°C;
- synthesis pressure came down to 54 kg/cm²;
- N/C was operating 2.98 to 3.0;
- CO₂ feed was cut first as the CO₂ compressor was tripped, NH₃ feed was cut after 3 minutes;
- When product becomes normal, Fe in final product was analysed and found to be normal <0.1 ppm;
- the material of the reactor liner, down comer and trays is 316L UG (BC.01).

We are investigating this incident and seeking technical assistance concerning this problem.

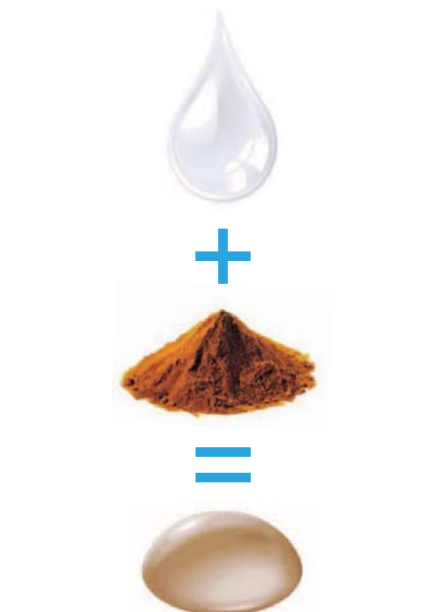

Add value, add profit.

SOLUTIONS FOR MULTI-NUTRIENT FERTILISER PRODUCTION



From mixing of liquid melts and solid additives, through environmentally-friendly Rotoform pastillation, to downstream handling and bagging, our continuous process solutions open the door to new possibilities in profitable, innovative and effective multi-nutrient fertilisers.

- Inline mixing of liquid and solid suspensions
 - Uniform, dust-free Rotoform pastilles
- Ultra-versatile production for easy product switchover
 - Low investment, low operating costs
 - Single source, end-to-end capability

Contact us to find out how we can enhance your products.



Sandvik Benelux B.V.

Dpt Process Systems · PO Box 248 · 3100 AE Schiedam/Netherlands
Tel: +31 10 208 0208 · Fax: +31 10 437 3780 · sps.blx@sandvik.com

www.processsystems.sandvik.com

Challenges for the Indian fertilizer industry

Dr M.P. Sukumaran Nair, director of the Centre for Green Technology & Management, looks at the various challenges facing the Indian fertilizer industry and how it fits into the Modi government's 'Make in India' policy.

The \$2.0 trillion Indian economy is set to achieve 7% annual GDP growth under prime minister Narendra Modi's government. But in order to sustain such figures, the major productive sectors of the economy – agriculture and industry – need a thorough revamping in order to boost productivity and growth. Therefore as a country India is confronted with two daunting challenges; attaining national food security, and reviving its manufacturing sector.

In the context of a global economic environment characterised by the shale gas revolution and consequent revival of the manufacturing sector in the US, an unprecedented and prolonged decline in oil and gas prices, European economies still in shambles, the Chinese economic downturn, easing of tensions in Iran and the political disturbances in West Asia caused by terrorist groups, all have impacted upon the Indian economy to a certain extent. But in spite this global turmoil the coun-

try hopes to maintain its growth impetus in the coming fiscal year. The Government has set an ambitious growth plan to revive the stagnant agricultural sector and invigorate the manufacturing sector. If the National Food Security Act (2013) commitments are to be honoured, the farm sector will have to considerably enhance its productivity of food grains. As regards the manufacturing sector, the intention is to grow its share in GDP from the current 15% to 25% and generate 12 million jobs by 2022. Most Asian economies' manufacturing sectors have contributed significantly to GDP growth because of the presence of a variety of cost efficient industries. If manufacturing picks up it will have a multiplier effect on other sectors and contribute to overall macroeconomic stability.

Is India suitably placed to generate such a manufacturing revolution? There are several favourable factors but also considerable challenges. The demographic dividend, availability of natural resources,

recent advances in science and technology, a stable central administration and the new image of the country as a land of opportunity, together with a widespread overseas diaspora are all positive ingredients to gather strength and advance into the future. But factors that take away the competitive advantage of Indian manufacturing include high costs of production, high energy and feedstock prices, unfair Government policies with regard to taxation, a poor business climate, environmental regulations, high interest rates, foreign exchange volatility, low employability of manpower, export/import hurdles, rising wages across sectors and enormous delays at the bureaucratic level in decision making (Table 1).

'Make In India'

Development-related policies have changed a lot in the last two decades. Still India may still have "miles to go" before

becoming a business-friendly nation. In this regard the 'Make in India' campaign of the Indian government is of paramount importance both in advancing the manufacturing of products in an economically and environmentally sustainable manner and also in streamlining the business environment by adopting the best available practices from already developed countries. It will not be possible for India's manufacturing sector to follow the path taken by the developed countries or that of China which is highly resource- and energy-intensive and also environmentally burdensome.

Here the big question remains: how can India pioneer a growth strategy for its manufacturing sector which is socially inclusive and environmentally sustainable? A high degree of optimisation of existing systems and processes, along with innovation to 'make more from less' will be needed; greater use of renewable energy, improving reaction efficiencies, inherently safe designs, waste reduction, adoption of biological processes and a product level life cycle approach are the areas to focus upon in achieving sustainable manufacturing.

This point can be illustrated with a case study from the fertilizer sector. This sector, despite having a strong domestic manufacturing base, is also heavily dependent on imports, and is inextricably linked to the agricultural development of the country. Agriculture contributes only 16% of India's GDP, although it employs 65% of the country's workforce. Between 1970 and 2011, the GDP share of agriculture has fallen from 43% to 16%. It has the potential to contribute 30% to GDP as was the case in the 1980s, provided that appropriate policies are in place. Though India attained self-sufficiency in food grain production in the mid-1990s, per capita availability of food grain has suffered a setback compared to the situation prevailing in the 1970s and 1980s (Table 2).

The Indian parliament passed the National Food Security bill in 2012, which provides for mandatory food security to cover about 67% of the population. Via this, the existing food subsidy scheme has been expanded to cover 180 million of the country's poorest people, who will receive around 4 million tonnes of food grain every month through a licensed 'fair price' shop. In effect, nearly 75% of the rural population (630 million) and 50% of the urban population (180 million) will be eligible to receive grain at a subsidised rate.

Table 1: India in statistics, 2015

Population	1.23 billion
GDP	\$2 trillion
Current GDP growth	7%
GDP contribution by sector:	
Agriculture	17%
Industry	28%
Services	55%
Demographics by age group:	
0-14	30.1%
15-64	64.6%
+65	5.3%

Table 2: India's agricultural sector 2014-15

Current food grain production, million t/a	
Rice	106.5
Wheat	96
Others	49
Total Cereals	245.5
Pulses	18.3
Total Food grains	263.8
Demand projection 2025	291
Demand projection 2030	342

In order to achieve the objectives of the food security bill, India may have to increase its grain output to 320 million t/a from the current 263 million t/a. Looking at the trend in food grain production there is a certain level growth, but that is not sufficient to meet this target and will have to be stepped up. It is well established that on average around 55-60% of food production is due to the use of mineral fertilizers to supplement plant nutrient needs. If you trace the course of history of agriculture and fertilizer production in the country it can be seen that in the 20 years between 1980

Table 3: Fertilizer situation in India 2014-15 million t/a

Item	Production	Import	Total consumption	Subsidy, \$ billion
Urea	22.59	8.75	31.34	5.88
DAP	3.45	3.85	7.3	}
NP Complex	7.83	0.29	8.12	} 5.041
Potash	0	4.28	4.28	}
Total	33.87	17.17	51.04	10.918

and 2000, both good grain production and indigenous fertilizer production flourished. By 2000, India had achieved self-sufficiency in food grain production and in the production of urea, the major fertilizer being consumed. Afterwards there were no further investments in the fertilizer sector and growth in grain production also slackened. It may be noted here India has indigenously developed total technical capabilities from conceptualisation to design, construction, operation and maintenance of world-class fertilizer plants. Imports went up due to the stagnation in domestic production at a time when demand is growing at about 5-6% per annum. Today India is the largest fertilizer importing country in the world and the consequent financial strain on the national economy is also heavy. Even when India is the world's second largest consumer, third largest producer and largest importer of fertilizer materials, its per hectare consumption of plant nutrients remains lower than China or developed agrarian countries (Table 3).

Major issues

The major issues in the fertilizer sector are:

- Growing consumption: the current consumption of 140 kg nutrient /ha is still lower compared to other agriculturally advanced countries and needs to be enhanced by taking into account a stable and sustainable NPK ratio in the soil.
- Inefficiency in application of fertilizer: the soil nutrient requirement is not given adequate importance in the current application of fertilizers. Price and availability have been the primary consideration instead, and this has resulted in an imbalance in the soil nutrient ratio.
- Increasing import of fertilizer: over the past over a decade imports have gone up considerably. Presently India is the

Table 4: Indian fertilizer joint ventures abroad

Project	Country	Participants	Product	Status
Oman India Fertilizer Co	Oman	Oman Oil Co 50%, Iffco 25%, Kribhco 25%	0.25 million t/a ammonia 1.6 million t/a urea	Op since 2006
ICS Senegal	Senegall	CS & IFFCO	0.55 million t/a phosphoric acid	Op since 2015
JIFCO	Jordan	JPMC & IFFCO	0.48 million t/a phosphoric acid	Op since 2014
IMACID	Morocco	Chambal 33%, TCL 33%, OCP Morocco 33%	0.425 million t/a phosphoric acid	Op since 1998
Tunisia-India Fert Co	Tunisia	CIL, GSFC (India), GCT (Tunisia)	0.36 million t/a phosphoric acid	Op since 2014

world's largest importer of N, P and K. This has also upset the fiscal balance in government budgets.

- Food security bill: in order to meet grain demand as envisaged in the National Food Security Bill, productivity of farm lands has to increase. This requires prudent application and increasing consumption of plant nutrients based on the right assessment of soil fertility.

In the near and medium term, the import of fertilizer-related raw materials, intermediates and finished products is only likely to increase. Considering a normal monsoon situation it is reasonable to expect a 5-6% growth in the consumption of applied fertilizers. Nitrogen plants in the country are working at almost their maximum capacities. Most of these plants have undergone retrofits and revamps so as to reach the maximum possible output and so it is not prudent to expect any more production from these plants. Thus the situation finally boils down to more and more imports every year. Even if a decision to put up new plants is taken today it will yield results only after a minimum of four years, which means that imports will continue to rise in the near term.

Feedstock

Shortage of natural gas is the main hurdle for expanding nitrogen capacity. The Chinese, in a similar situation, turned to coal, and built a string of ammonia/urea plants based on coal gasification which are operating economically. Although India gained experience in the initial stages in operating coal-based ammonia plants at Ramagundam and Talcher in the 1970s, the government decided to close down these plants on account of low productivity. Coal gasification technology over the years has become better, more environ-

ment friendly and profitable – as is well illustrated from the Chinese experience. In the present context India may have to look at coal gasification as a major avenue for the production of ammonia through clean coal technologies.

Though efforts to increase domestic natural gas production did not succeed, gas is available in the form of LNG at an affordable price. The lack of a national gas pipeline grid to deliver regasified LNG is a major hurdle, however. Construction of gas pipelines is being resisted by agricultural and environmental groups in different parts of the country and there is litigation. The industry expects a favourable decision to pave the way for construction of pipelines and the State governments to amicably resolve disputes with the farmers. But proposals to extend gas pipelines by another 15,000km, a renewed focus on accessing coalbed methane and a thorough revamp of fertilizer policy in the 2015 budget have yet to be realised.

In the phosphate sector, the price of products have increased tremendously in the overseas market and hence also in India, especially after the adoption of the nutrient-based pricing strategy for P and K fertilizers. Imports of raw materials like rock phosphate and sulphur is becoming critical and consequently operating margins are declining. It would be necessary for Indian manufactures to enter into long term contracts for supply with overseas suppliers, and operate joint venture facilities in countries where raw materials are available or acquire fertilizer assets abroad for developing and producing for the Indian market, like those pre-existing companies show in Table 4.

In the case of potash India has no source of indigenous supply. The entire requirement is met by imports and here India also may have to go for either joint ventures or the acquisition of overseas assets.

Speciality fertilizer and micronutrients

Across the world agriculture is witnessing sea changes at the advent of new technologies and innovation. Precision agriculture, fertigation, integrated nutrient supply and administration of plant nutrient based on soil analysis are becoming accepted as the basic tenets of improving crop productivity. Secondary and micronutrients play a vital role in this regard. Micronutrients like boron and zinc came under India's subsidy scheme via amendments to the Fertilizer Control Order in 2010. The soil in certain parts of India has been recognised as highly deficient in sulphur, zinc etc. Specially designed nutrient formulations, and the fortification of fertilizers with micronutrients are essential to sustain productivity during intensive cultivation. The proposal to provide a soil 'health card' to farmers is would be a positive step in addressing the declining trend of crop yields from Indian farms.

The Uttar Pradesh government has over the past ten years meddled with fertilizer policy on several occasions and every time it proved futile and investors' interest in the sector faded. Fertilizer projects are highly capital- and energy-intensive. Lack incentive for investments, lack of clarity/uncertainty in the pricing and subsidy regime, enormous delays encountered in the disbursement of subsidy, and material becoming readily available in the international market have all impacted up on growth impetus of the industry.

In order to make up for the shortage of natural gas, import of liquefied Natural Gas (LNG) has been considered by the government. Currently four LNG terminals are operating in the country; at Dahej and Hazira in Gujarat, Dabhol in Maharashtra and Cochin in Kerala. A few others are also planned on the western and eastern

DEMAND MORE

Diversify your product mix with melamine.



LEM™ Low ENERGY MELAMINE PROCESS BY CASALE

www.casale.ch

Extend the nitrogen value chain



Table 5: Indian fertilizer joint ventures under consideration

Country	Entities	Product	Offtake agreement
Iran	RCF, GNFC and GSFC from India and one partner from Iran	Ammonia, Urea	0.8 million t/a ammonia, 1.27 million t/a urea
Russia	NMDC, RCF, FACT, KRIBHCO, NFL (India) and ARCON (Russia)	Potash	30% stake in the project
Canada	RCF, FACT (India) & ENCANTO (Canada)	Potash	1.8 million t/a for 17 years

coasts. Because of a wide variation in the pricing of domestically-produced natural gas and re-gasified LNG, capacity utilisation at all the terminals except for Dahej remains low. In order to overcome this precarious, it is essential that a national pipeline network is in place and a rationalised pooling of gas price like any other fuel is inevitable.

The world's first coalbed methane-based urea plant has been built in West Bengal, but even though the construction of the plant is complete the supply of feedstock, which is to come from the Jharia and Raniganj coal fields is yet to be established. Such policy indecisiveness makes huge investments unfruitful and investors in the sector will be discouraged forever (Table 5).

Solution

In the context of ever-increasing imports, it makes sense for fertilizer manufacturing India to form part of the Modi government's 'Make in India' programme. A multi-pronged strategy to sustainably address the problems confronting this vital sector needs to comprise:

(i) An increase in domestic production

There has been no new investment in urea plants since 1995. Most of the urea plants in the country are operating near to their full-rated capacities. Government efforts to increase domestic production have not yet been successful, and natural gas availability is the major hurdle. In the near term, a marginal increase in production of urea is expected from revamping of some of the closed units, with natural gas as feedstock.

Domestic production essentially needs to be stepped up to meet at least half of imports over the next five year period. A standard plant size of the order of 800,000 t/a of urea, based on natural gas and the latest energy-efficient technology is the

right option. It is also possible to pursue advanced clean coal technology for the manufacture of ammonia, which has now come of age. Refinery-linked fertilizer production is also to be considered in order to make use of vacuum residue, petroleum coke, refinery off-gases etc as feedstock for making synthesis gas via an integrated gasification route.

Besides this, the mineral fertilizer industry should also ally with producers of organic manure and bio-fertilizers, both of which are at present an unorganised sector. Composting of biomass and municipal waste to make organic manure also needs to be integrated into the framework of a holistic nutrient prescription for agriculture. Formulation of crop-specific specialty fertilizers can be another important contribution to the sustainable use of mineral fertilizers.

Thus the new fertilizer manufacturing program under the 'Make in India' perspective must align the efforts of the fertilizer industry, government and research institutes for the common goal of ensuring Indian agricultural sustainability.

(ii) A balanced import programme

With increasing fertilizer consumption, rising imports and consequent large foreign exchange deficit, a three-pronged approach is essential. This involves producing units entering into long term supply contracts with foreign suppliers, developing joint ventures with overseas producers and encouraging Indian companies to buy fertilizer assets abroad

(iii) Proper application of nutrients

Excessive application of plant nutrients to the soil does not increase crop productivity, and can spoil ground water quality through leaching and bring financial loss to the farmer. Thus a prudent system of nutrient administration at the right time and in right amounts is necessary. Growing plants absorb only the required nutrients from the

soil and do not differentiate on the basis of price or availability. Therefore, an effective programme for testing the soil nutrient requirement of farmlands is needed to advise farmers on the proper application of fertilizers. This can also be supplemented by a nutrient-based pricing scheme for all fertilizer material. Industry should gear up its efforts to improve farmers' awareness on 4R Nutrient Stewardship. The 4R philosophy is being promoted by the Fertilizer Institute in the USA in collaboration with the International Plant Nutrition Institute (IPNI), the International Fertilizer Industry Association and the Canadian Fertilizer Institute (CFI), and is an innovative and science-based approach that offers enhanced environmental protection, increased production, increased farm profitability, and improved sustainability. We may adopt this concept is to use the right fertilizer source, at the right rate, at the right time, with the right placement in our fields.

(iv) Curbing leakage in the transfer of subsidies

The current subsidy administration pays the requisite subsidy to producer companies based on the quantities they produce and send to the market. Instances of large-scale manipulation have been observed in this system. The government is thus attempting to switch to a direct transfer of subsidy to the farmers. A few pilot plant trials have taken place, based on the results of which a nationwide implementation of scheme is now expedited.

Revitalising the domestic production of fertilizer materials on the above lines, together with mandatory guidelines for proper use and a balanced import strategy for resources not available in the country under the 'Make in India' program can ensure sustainability in all respects – increased productivity of farm lands, lower environmental burden in manufacturing and reduced dependence of imports, as well as huge financial gains. ■



Changing economics and availability of feedstocks around the world are leading to increased interest in moving plants from one location to another.

Main pic: Methanex has relocated two of its Chilean methanol plants to Geismar, Louisiana. Above: AzMeCo's new methanol plant in Azerbaijan.

Nitrogen+Syngas 341 | May-June 2016

Relocating a chemical plant that still has useful life left in it, or even just cannibalising an existing plant for parts, can help bring down the cost of setting up a methanol or ammonia plant by a considerable amount. In previous decades, with gas costs increasing in Europe and North America and plants closing down, new producers in Asia, Russia and other parts of the world often saw buying a used plant that had been well looked after as a cheap way of getting a foot on the ladder as an ammonia/urea or methanol producer. Many plants in countries like India and China initially began their lives in Europe and the US, being relocated during the 1980s and 90s. This is a process that still occurs – AzMeCo's new methanol plant in Azerbaijan, which began operations in 2013, was based around an old plant relocated from the US.

Nowadays, with gas and even coal feedstock markets volatile and subject to major shifts in cost structure, and with feedstock costs being such a major component of plant economics, it can even make sense to uproot a plant wholesale from a place where gas is no longer cheap or even available to one where it is cheap and abundant. One of the most notable recent examples of this on the methanol side has been Methanex's decision to dismantle two of its methanol plants at its site at Punta Arenas on the southern tip of Chile – where the company no longer finds itself able to buy gas across the border from Argentina – all the way to the US

Gulf Coast, rebuilding them at Geismar in Louisiana.

Gas economics

The gas-side economics of such projects can be compelling. During the 1990s, Arcadian relocated an ammonia plant from California to Point Lisas, Trinidad. At the time, US natural gas prices averaged around \$4.00/MMBtu, but already increasing demand and falling supply were pushing prices higher, and during the 2000s US gas prices averaged around \$6.00-7.00/MMBtu and peaked as high as \$15.00/MMBtu. The effect was even more pronounced in Europe, where gas prices were indexed to oil, and the average figure was more like \$10-12.00/MMBtu. At the same time natural gas could be had in Trinidad for around \$1.75/MMBtu plus a cost escalator based on ammonia prices, and averaging perhaps \$2.50/MMBtu. Saving \$3.00/MMBtu on natural gas costs could represent \$100/tonne of ammonia in terms of production cost – enough to make almost any plant profitable again. The Arcadian plant became part of PCS when Arcadian was acquired in 1997, and PCS Nitrogen still operates that unit at Point Lisas.

Now of course the boot is on the other foot, and in the US Henry Hub gas can be bought at around \$2.00/MMBtu, while Trinidad faces gas curtailments as production has lagged behind domestic demand, and so the impetus is to move plants back

www.nitrogenandsyngas.com

www.nitrogenandsyngas.com

Nitrogen+Syngas 341 | May-June 2016

CONTENTS

What's in issue 341

COVER FEATURE 1

Long-term fertilizer demand

COVER FEATURE 2

Challenges for India

COVER FEATURE 3

Sulphur-enhanced urea

COVER FEATURE 4

Optimising catalytic reactors

NITROGEN+SYNGAS
ISSUE 341
MAY-JUNE 2016

BCInsight

Southbank House, Black Prince Road
London SE1 7SJ, England

Tel: +44 (0)20 7793 2567

Fax: +44 (0)20 7793 2577

Web: www.bcinsight.com
www.bcinsightsearch.com

to the US, where they are closer to centres of demand, and hence avoiding the cost of having to ship ammonia, urea or methanol from halfway around the world, a significant cost addition in its own right even in these times of overcapacity in the shipping industry and lower international freight rates.

There are, however, cautionary tales; feedstock availability remains a key issue for relocating plants. For example, during the 1990s, India's Southern Petrochemical Industries Corp (SPIC) attempted to move a 400,000 t/a second-hand ammonia/urea plant from Sri Lanka to the Jebel Ali Free Trade Zone in the United Arab Emirates, expecting to tie the plant in to the new Dolphin pipeline from Qatar which was at the time under construction. However, other gas consumers were given higher priority and the project foundered on availability of natural gas, while the plant sat on a dockside in crates for years before the scheme was finally abandoned.

Plant economics

As well as taking advantage of lower feedstock costs or better feedstock availability, the economics of using a used plant can be compelling in their own right as compared to the high costs of a new build. The typed of chemical plants where the economics of relocation make the most sense tend to be those with a substantial amount of high pressure/temperature piping, with expensive alloy steels and many major rotating equipment items like compressors and turbines. This makes ammonia, methanol and nitric acid plants especially suitable to relocation and refurbishment. According to CPI Consultancy, relocation of a second hand plant can typically be done at 60-65% of the cost of a new plant (assuming that the actual purchase price of the old equipment is about 5% of that of buying it new), and can be completed in a shorter time frame. Other estimates put the cost as low as half of that of a new build (see *Nitrogen+Syngas* 303, Jan/Feb 2010, pp38-41 and *Nitrogen+Methanol* 265, Sept/Oct 2003, pp22-27).

Once again, though, there can easily be unforeseen costs – Methanex's relocation reportedly went \$300 million over budget because of shortages of skilled labour. The company ended up paying welders and pipefitters more than \$100/hour – 20% more than expected – in order to retain them in the face of a local oom

in the US chemical industry that is leading to hundreds of new projects across all industries. A worse fate befell the World GTL plant in Trinidad, which was based on mothballed equipment from various sites, including a reactor from a Delaware methanol plant and a hydrocracker from Guatemala. Spiralling construction costs and Petrotrin calling in a loan forced World GTL into receivership in 2009 and began a long and costly legal wrangle over the project.

Technical considerations

Purchase and relocation of an old plant throws up a variety of issues not encountered with a new build, and hence a project must be managed just as tightly as would construction of a grassroots facility. This begins right at the time of project feasibility study. For example, selection of the right plant to relocate is of course of paramount importance. Old, high maintenance or obsolete facilities are obviously poor choices for relocation, however cheap they may be! A relocated plant should expect to achieve at least 10 years of operational life, and this will affect assessment of the lifetime of individual equipment items. How the plant will interface with any existing facility is also important – a used plant can be an excellent choice for sites which already have existing operations, where the new plant will enhance capacity or allow production of a new side stream, perhaps one with synergies to the main process which ultimately reduces overall production cost and adds value to the facility. The relocated unit may also be able to take advantage of existing utilities and off-sites.

Relocation of an old facility, especially one where not all of the major equipment items are still serviceable, also affords an opportunity for revamping, and there are numerous options which can be considered. Some licensors specialise in revamp options for typical old plants which can add capacity and increase efficiency. This can be of particular importance where a plant will be expected to meet higher environmental standards than it was originally designed to do, and various add-on emissions control technologies must be considered.

Documentation can be a key concern. A used plant – especially one that has been mothballed or shut down for some years – may not have up to date facility layout plans and engineering diagrams, which may have to be developed as part of the project. Ascertaining the condition of the

plant is especially important, particularly if key documentation is missing and personnel who were familiar with equipment or procedures long moved on. Hence a detailed equipment review and condition assessment needs to be performed before detailed relocation planning, and each equipment item needs to be separately logged. It can cost more to repair, upgrade and relocate any particular piece out-of-condition equipment, especially if there are metallurgical defects, than it does to replace it. There can also be peculiarities to particular sites – previous or new – as regards weather conditions. Moving a plant that has operated in freezing temperatures to a desert environment or vice versa can place additional stress loads on equipment which they were not designed for.

For this reason, development of the overall plan for a relocation project is perhaps the most important and most difficult aspect of plant relocation. Scheduling is a particular concern, especially as regards sequencing of shipping specific items and infrastructure to avoid construction bottlenecks or extra shipping costs by shipping piecemeal.

Finally, safety must be a concern at all stages of the move. Decommissioning of the old site can bring its own hazards and costs, especially as regards disposal of toxic substances such as asbestos. Old plants which have been left idle for some time can have had safety considerations ignored. Load bearing structures may have weakened, vessels may have been left part filled. Safety procedures, such as confined space entry permits, hot work permits etc. must be fully enforced. The same applies for the use of personal protective equipment. Process and utility tie-ins must be safely blanked or isolated.

Modular construction

One of the current trends in the industry, especially as regards smaller-scale plants which do not require large, specially-built sections which may be too big to fabricate off-site and transport, is towards constructing a plant in modular sections which each can be shipped as a whole. This makes for more convenient reassembly at the other end, and, from a fabricator's point of view, allows better control over quality of steel, welds, etc. However, could modular construction also make a plant easier to relocate according to changing feedstock conditions? ■

CEAMAG
PROCESS ENGINEERING

THE WORLD OF
FERTILIZERS
PRODUCTION

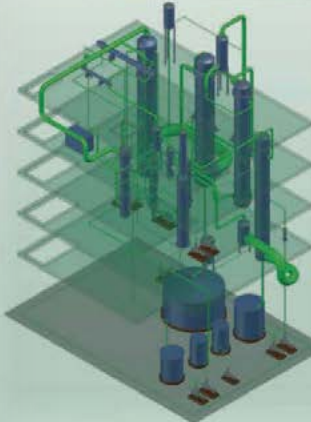

FROM FEASIBILITY STUDIES TO TURNKEY CONTRACTS, under a flexible and reactive organisation, CEAMAG provides full range of services for implementation of your Fertilizers projects, focusing on improving your plants performances. CEAMAG brings its own technical solutions resulting of years of experience applied to tailor made projects for answering to Customers specific requirements. In addition to its own know-how, CEAMAG proposes the most effective technologies from worldwide accepted Licensors based on long term partnerships.

- SERVICES**
- Project Financing
 - Process Development
 - Project Management
 - Engineering services
 - EPC contractor
 - Consulting
 - Technical assistance



- TECHNOLOGIES**
- Ammonia plants revamping
 - Urea synthesis revamping
 - Urea granulation
 - Nitric acid mono and dual pressure processes
 - Ammonium Nitrate synthesis and granulation (AN, CAN, ANS, AN based fertilizers)

CONTENTS

What's in issue 341

COVER FEATURE 1

Long-term fertilizer demand

COVER FEATURE 2

Challenges for India

COVER FEATURE 3

Sulphur-enhanced urea

COVER FEATURE 4

Optimising catalytic reactors

NITROGEN+SYNGAS
ISSUE 341
MAY-JUNE 2016

BCInsight

Southbank House, Black Prince Road
London SE1 7SJ, England
Tel: +44 (0)20 7793 2567
Fax: +44 (0)20 7793 2577
Web: www.bcinsight.com
www.bcinsightsearch.com



PHOTO: BENGO INSTITUTE

Long-term demand for fertilizer

New nitrogen production plants are predicated on increases in fertilizer demand – something which has seen steady increase for decades now. But can such trends continue indefinitely, or is there a slowdown in global nitrogen demand growth ahead?

The increased use of fertilizer over the course of the 20th century has been one of the great success stories in human achievement, allowing us to feed a global population that has now topped 7 billion people without the onset of catastrophic famine worldwide – something which was widely feared during the 1960s, when Stanford biologist Paul Erlich wrote his neo-Malthusian book 'The Population Bomb', its title designed to indicate that the effects of overpopulation would be every bit as devastating as that other concern of the era – the atomic bomb. The book began with the now infamous statement: "The battle to feed all of humanity is over. In the 1970s hundreds of millions of people will starve to death in spite of any crash programs embarked upon now. At this late date nothing can prevent a substantial increase in the world death rate."

While the world has seen famines, especially in the Horn of Africa in the 1980s, his alarmist projections did not, fortunately, come to pass, and the fact

that Erlich was so wrong was in large part due to the work of another American biologist, Norman Borlaug, whose work with developing economies, especially India, helped pioneer the use of faster growing varieties of crops, and in particular the increased use of fertilizer, in what has become known as the 'Green Revolution'. Thanks to our ability to artificially fix nitrogen via the Haber-Bosch Process, billions of people are alive today who might otherwise have perished, and the world is not in danger of running out of food as population continues to increase.

The increase in demand for nitrogen fertilizers has created the industry that this magazine, itself founded in 1959, has covered for the past fifty-seven years. Global ammonia production now totals just under 140 million tonnes of nitrogen (170 million tonnes product), of which just over 80% is destined for fertilizer products. But where will that figure go as the 21st century unfolds?

Left: Wheat is one of the major consumers of nitrogen fertilizers.

Steady growth

One way to look at this is to see where we have been. Figure 1 shows historical nutrient demand for the three major nutrients from 1960-2005¹. Nitrogen demand is shown in blue, phosphate in red and potash in green. While the trend is generally upwards in most major regions, especially those like East Asia and the Rest of Asia where the concentration of people and demand is greatest, it also shows that demand in some regions has peaked and then fallen – in the European Union from over 14 million tonnes N in the late 1980s to just over 10 million tonnes N in the 2000s, while in North America demand can be seen to be plateauing. Demand in Eastern Europe and Russia (rendered in Figure 1 as "Rest of Europe") has fallen significantly, from 12 million tonnes N in the late 1980s to just over 10 million tonnes N in the 2000s, and when demand did recover, it was discovered that wasteful practices under communism had resulted in up to one third of grain and other foods produced spoiling before they reached consumers, hence less fertilizer was required to produce food. But it is also because rural economies have still not fully recovered in some of those countries, and there is still room for growth.

In the short to medium term, fertilizer growth continues at a relatively steady rate of around 2% per year. However, ammonia and urea plants that are being built today might be expected to have an operational lifetime of at least 20-30 years, and there are still plants operating today that were built in the 1960s and 70s, up to fifty years later, and simply projecting a demand trend line into the future is unlikely to produce an accurate forecast of longer-term fertilizer demand.

Population

One of the easier factors to project forward is demographics, in particular population increases, as we know today pretty much how many people of child-rearing age there will be in 20 years time, and can make good guesses at trends in fertility. While

the world's population has grown significantly over the 20th century, the rate of population growth continues to steadily fall, and is presently just over 1% per year. In almost all countries, as it did during Britain and Europe during the Industrial Revolution of the 18th and 19th centuries, fertility rates follow a pattern set by rising incomes and increasing urbanisation, and eventually fall below replacement population rates, as they have already done in Europe, Japan, North America, Australasia and more recently even Iran, China and Brazil. While fertility rates remain high in sub-Saharan Africa, in most of the world populations are either below replacement level or are expected to reach there in the next couple of decades.

The UN currently projects that world population will slowly inch towards around 10

billion by the end of the decade, but these estimates have been progressively revised downwards, and a growing number of forecasters, such as India's Sanjeev Sanyal, now see the peak coming much sooner – perhaps around 2050, at around 9 billion people – and declining thereafter. If population growth were the sole source of nitrogen demand growth, then, we would expect growth rates to slow and eventually reverse.

Incomes

The other major driver of fertilizer growth over the past few decades has been rising incomes in the developing world. The theory is that as people get richer they begin to include more meat in their diet, which in turn requires more land given over to raising crops to feed animals, and hence more

fertilizer. This also makes sense from the perspective of farmers getting richer and being able to afford more fertilizer. Figure 2 shows global nitrogen fertilizer demand growth (in blue) on the left hand axis, and global GDP/capita (in inflation-adjusted dollars) on the right. Using GDP per capita, thus strips out the effect of rising population. While fertilizer demand growth out-paced growth in global incomes during the 1960s and 70s (when the increase in fertilizer use was presumably dominated by rapidly increasing global population), from about 1980 onwards there does seem to be a correlation of sorts between the two.

Again, however, as with population trends, there is a question mark as to what extent this relationship will continue into the future. While global wealth seems sure – barring occasional slumps like 2008 –

Fig 1: Nutrient consumption in major regions, million t/a, 1961-2006

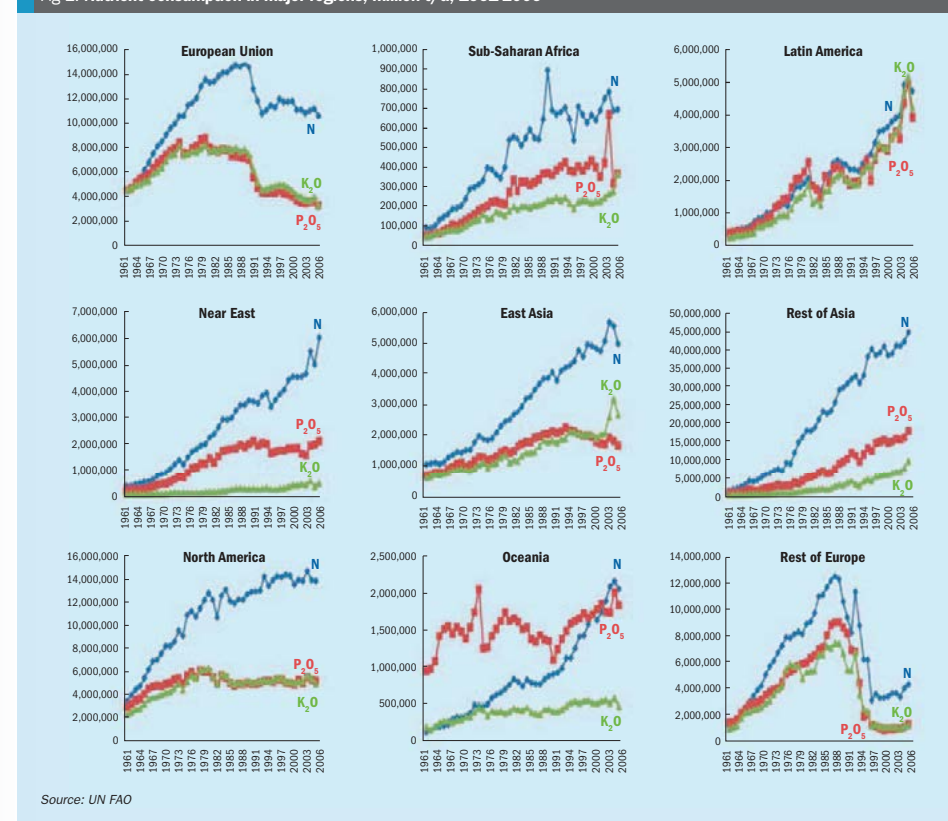

Source: UN FAO

Fig 2: Nitrogen demand vs incomes, 1961-2014

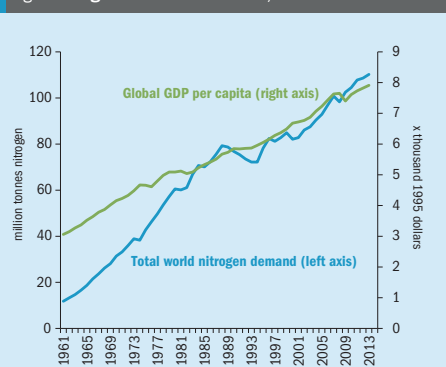

Source: IFA, UN

to continue to increase, there is presumably only so much food that a person can consume (even taking into account the world's growing obesity epidemic), and in most developed countries the relationship between wealth and protein consumption no longer applies. As more and more countries reach developed world levels of income, so this factor is likely to top out, and may not be as relevant by 2050 as it is today, although some studies indicate that there may still be a way to go yet before consumption levels peak in most of the developing world.

Perhaps the one major regional exception, as with population growth, is likely to be sub-Saharan Africa, where incomes, food productivity and fertilizer application rates all languish at low levels. Africa is the one major global region not to have yet benefitted from a 'Green Revolution' in the way that e.g. Asia and Latin America have. Africa currently represents about 13% of the world's population, and while this is expected to rise to 25% by 2050, fertilizer demand growth in Africa may not be able to replace slackening growth elsewhere.

Over-application

Intensity and efficiency of fertilizer application is the third major component of the demand equation. Nutrient use per hectare varies considerably around the globe, from around 100-300 kg nutrient per hectare (in terms of the three primary nutrients – N, P and K) for the richer economies and 50 kg or less for the poorer ones, of which

at least half tends to be nitrogen. However, in most countries a good proportion of this is provided by manures and other natural sources of fertilizer, and the overall application rates of mineral fertilizers are around 110-180 kg nutrient per hectare for most of the world (but as low as 20 kg per hectare for Africa). Varying crop types can also play a part in the demand for fertilizer, according to each plant's requirement for nitrogen. But by and large the staples of human consumption are food grains, mainly wheat and rice, and these tend to be more intensive consumers of nitrogen.

Plant uptake of nutrient is the limiting factor for removal of nutrient, and where fertilizer is over-applied or applied at the wrong season, in excess it can leach into watercourses and cause algal blooms and anoxia in water. This became such an issue in Europe during the 1980s that a conscious effort was made to apply less nitrogen and phosphorus and to better target fertilizer application to minimise runoff. The success of this policy has led to Europe's steady lowering of nitrogen consumption as noted above, and other countries are gradually following suit.

Imbalanced fertilizer application can also be an issue, as occurs in India. Figure 3 shows fertilizer application and yield in a variety of countries². Although India applies as much nitrogen as other countries which achieve better yields, its fertilizer subsidy policy has pushed urea at the expense of other fertilizers, and the lack of P and K means that nitrogen uptake is inefficient.

Fig 3: Nutrient use vs cropyield, 2014

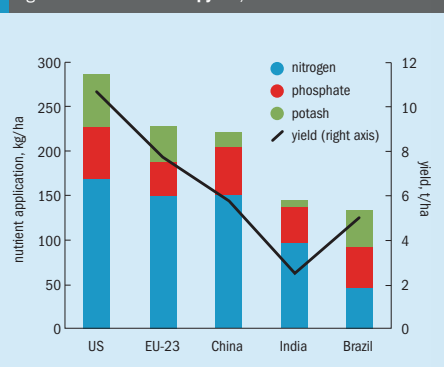

Source: Agrium

Government policy is the key determinant for this demand factor, and moves to apply fertilizer more efficiently are likely to see overall demand fall over the longer term. China, which applies over 300 kg nutrient per hectare, in common with other east Asian countries like Vietnam and South Korea, recently announced a nutrient cap, aiming to level demand for fertilizer at 2020 levels, and thereafter decrease it by instead applying fertilizer in a more targeted manner. As China represents 35% of global fertilizer consumption, this is a significant straw in the wind.

Cultivated area

In tandem with nutrient use per hectare is the total area under cultivation. Here the change has been fairly small, however. While there have been some new lands brought under cultivation, for example in Brazil's *cerrado* region, land has also been taken out of cultivation – in the EU, for environmental reasons, and in countries like China, where increasing urbanisation has reduced the land available for farming. According to the UN Food and Agriculture Organisation, total cropped area rose from just under 1.4 billion hectares in the 1960s to about 1.5 billion hectares in 1990, and has stayed relatively constant at that level ever since. The astonishing gains in agricultural productivity over the past 50 years have come from much the same amount of land. The prospects for the future are, if anything, a very slight reduction in overall

cropped area due to increasing population and urbanisation³.

Climate change

Finally, the effect on crop-growing areas of climate change is a major imponderable for future demand. At one time, so-called "creeping desertification" was the worry, especially for parts of Africa like the Sahel, but data from satellite remote sensing appears to show that while rainfall patterns have changed across Africa and the world, the actual amount of vegetation around the world has overall increased, as one might expect in a warmer world with more carbon dioxide available for plants⁴.

There are various other factors, including severe weather events which can lead to major droughts, sometimes for several years, flooding, and delayed or especially heavy monsoons, all of which can affect food output, but as farmers plant in the expectation of 'normal' weather, these may not affect actual demand as greatly as they do output. Climate change may also affect the type of fertilizer required. Shorter growing seasons require quicker uptake of nutrient by plants, which is why ammonium nitrate-based fertilizers are favoured in Europe and Russia, as the nitrogen is present in available nitrate form, whereas urea must be hydrolysed to nitrate before it can be taken up by plants.

Attempts to cut global greenhouse gas emissions could bear down on producers via government policies and so-called 'carbon taxes', but consultants who have looked at the issue have indicated that these measures are unlikely to have as much impact as policy initiatives to

cut waste and improve efficiency of use (which will also have the desired impact on CO₂ equivalent emissions anyway), and of course fertilizers in general provide towards capturing carbon from the atmosphere via uptake in plants.

Long-term forecasts

So where does that leave us in terms of long-term forecasts for fertilizer use? Slowing population growth and saturation in terms of protein consumption indicate that growth is likely to become slower in the longer term, and government attempts to prevent over-application and better targeted use of fertilizer are a factor that could push demand downwards. There is no real prospect of any great increase in cultivated area – if anything the reverse. Climate change may be disruptive to individual countries or regions, but may not have any major effect on fertilizer demand.

The UN FAO study quoted at the start of the article¹ attempted to deduce the arithmetical effect of current trends in data and projected total global agricultural nitrogen demand at 137.4 million tonnes N by 2030, which would represent a growth rate of around 1.1% per annum – much lower than the 1.7-1.9% typically used for short and medium term forecasts at the moment. However, a subsequent University of Freiburg study² attempted to extend the FAO study to 2050, and calculated that, while population will increase to an estimated 9.3 billion by 2050, or around 30%, food demand will increase by 70%, as a result of the urbanisation and rising incomes that we have discussed, and that this additional increase

could not be met with additional artificial fertilizer, and hence their projected nutrient demand growth back towards 2.2% per annum from 2030-2050. Personally, I feel that this number is excessive, and is perhaps the result of merely projecting current trend lines rather than addressing the various longer term factors which we have discussed. In particular it fails to take into account increasing efficiency in fertilizer application in these regions and the effect of government policy, nor of course can it (nor does it seek to) account for any potential technological breakthroughs that might occur, such as genetically modifying crops to be able to fix nitrogen directly from the air – something which we reported on in *Nitrogen+Syngas* in 2013. For what it may be worth, a better estimate for long-term growth would in the author's opinion probably be closer to the 1% of the UN FAO study than the 2.2% of the Freiburg one, and while we may not see 'peak nitrogen demand' until the second half of this century, the bet for very long term growth would be lower rather than higher. ■

References

1. F. Tenkorang, J. Lowenberg-DeBoer, *Forecasting Long-Term Global Fertilizer Demand*, UNO FAO, 2008.
2. Agrium Fertilizer Industry Factbook, 2014-15.
3. J. Ausbel, I. Wernick, P. Waggoner, *Peak Farmland and the Prospects for Land Sharing*, The Population Council Inc., 2013.
4. R. DeJong et al, 'Analysis of monotonic greening and browning trends from global NDVI time series', *Remote Sensing of Environment*, October 2010.
5. A. Dreschler, R. Glaser, C. Richert, K. Nippes, *Demand for key nutrients (NPK) in the year 2050*. University of Freiburg, 2011.

FREE WEBINARS AND PRESENTATION SLIDES:

Nitrogen | Phosphate | Potash | Sulphur

Integer Research are delighted to offer you free access to our market outlook webinars and presentation slides for nitrogen, phosphate, potash and sulphur markets.



FREE ACCESS HERE: www.integer-research.com/free2015



CONTENTS

What's in issue 341

COVER FEATURE 1

Long-term fertilizer demand

COVER FEATURE 2

Challenges for India

COVER FEATURE 3

Sulphur-enhanced urea

COVER FEATURE 4

Optimising catalytic reactors

NITROGEN+SYNGAS
ISSUE 341
MAY-JUNE 2016

BCInsight

Southbank House, Black Prince Road
London SE1 7SJ, England
Tel: +44 (0)20 7793 2567
Fax: +44 (0)20 7793 2577
Web: www.bcinsight.com
www.bcinsightsearch.com

A new approach to sulphur-enhanced urea

Shell and Ude Fertilizer Technologies (UFT) have joined forces to integrate Shell's Urea-ES technology with UFT's fluid bed granulation technology to produce a new sulphur-enhanced urea fertiliser technology. This article presents the fluid bed granulation process for producing Urea-ES products, the potential agronomic value and cost benefits of these products, and how they can be manufactured in new and existing urea fluid bed granulation plants.

Shell Sulphur Solutions has been developing technologies to produce sulphur-enhanced fertilizers, with complete R&D & deployment programs, including testing at pilot plant scale, since 2003. Today, these technologies are known as Shell Thiogro technologies. The first phase of these technologies focused on incorporating sulphur into ammonium phosphate and triple super phosphate fertilizers.

In 2011, Shell performed the first bench work on an elemental sulphur emulsion in molten urea, in order to prove the viability of the idea. These original tests led to further development, including a scale up to the one tonne/hour continuous drum granulation pilot plant at the International Fertilizer Development Centre (IFDC) in Muscle Shoals, USA.

Once the concept was proven, in-depth product stewardship and agronomy programs began on numerous topics and crops in select geographies. Topics studied include: crop response, sulphur oxidation in different soils, process safety, toxicology and end-user environmental stewardship, among others.

Urea-ES technology was publicly launched in 2015. This new technology disperses finely micronised elemental sulphur into conventional urea fertilizer, producing formulations such as 43-0-0 7S up to 35-0-0 23S and nutrient densities as high as 58%. Fertilizers produced using Urea-ES technology have demonstrated significant agronomic responses in preliminary Shell and third party trials to date. In addition, these sulphur-enhanced urea



Urea-ES sulphur-enhanced urea (43-0-0 7S), granulated with UFT's fluid bed granulation technology.

products can create logistical and application cost benefits over lower density fertilization programs.

In early 2015, Shell and UFT began a program to incorporate Shell Thiogro sulphur-enhanced fertilizer technology with UFT's fluid bed granulation technology.

To date, considerable amounts of resources have been dedicated to furthering the development of this technology, and significant amounts of experimental and design data have been collected. This has enabled advancement in all aspects of product stewardship. This data and product stewardship information is currently being used for industrial scale-up.

What is Urea-ES technology?

Urea-ES technology seeks to enable fertilizer producers to incorporate elemental sulphur into their urea fertilizer, as a convenient and cost effective way of providing plants with the sulphur nutrition they need.

Elemental sulphur is the most concentrated form of sulphur; it is a readily available and cost effective raw material, making it an economical source of plant nutrient sulphur. However, since plants take up sulphur nutrient in the form of the sulphate ion, bacteria in the soil must oxidise elemental sulphur before it is available to the plant.

To accelerate this oxidation process, Shell has developed a process that micronises the elemental sulphur into fine particles of, on average, less than 40 microns, significantly increasing the surface area accessible to soil bacteria. This way, the elemental sulphur can be oxidised across the entire crop growth cycle, helping to offer a season-long supply of sulphur nutrient.

While the Shell technology safely and efficiently combines urea and sulphur into a stable emulsion, before it can be sold it must be granulated. Shell and UFT are co-operating to develop an end-to-end Urea-ES fluid bed granulation process for producing granular sulphur-enhanced urea.

Why sulphur-enhanced urea?

Sulphur is a plant macronutrient, and plays an important role in the development of proteins in crops. In recent years, the importance of sulphur has become a significant topic in the agricultural community, due to the rising incidence of sulphur deficiency in soils across the globe.

There are three commonly accepted reasons for the growing soil sulphur deficiency globally:

- the shift away from lower analysis, sulphur-containing fertilizers like SSP and ammonium sulphate, towards higher analysis fertilizers like MAP and DAP;
- increasingly stringent sulphur limits on fossil fuels, leading to less sulphur deposition from the atmosphere, and;
- the use of higher yielding crop varieties, which take up more nutrients, including sulphur, out of soils.

Over the last several years, the fertilizer industry has responded to sulphur deficiency with the introduction of various sulphur-containing fertilizers. However, these innovations have not been enough to eliminate the deficit, and the sulphur gap continues to grow. In 2015, the Sulphur Institute estimates that approximately 10 million more tonnes of sulphur were taken out of soils than were replaced. As the most widely used fertilizer globally, both geographically and by volume, urea is seen as an ideal sulphur delivery vehicle to help respond to the global soil sulphur deficiency.

The value of sulphur-enhanced urea

Sulphur-enhanced urea has the potential to create value for the fertilizer producer, through the distribution chain and finally at the farm.

At the fertilizer manufacturing facility, replacing a portion of higher-cost urea liquor with lower-cost sulphur can reduce overall input costs to the manufacturer. In addition, in markets that recognise the importance of sulphur as a plant nutrient, fertilizer producers may be able to sell sulphur-enhanced urea at a premium price over regular urea. Premium pricing for sulphur-containing products is well documented in markets such as North and South America, and Europe, for example.

Due to their high nutrient density (46% nutrient in 46-0-0 urea vs. 53% nutrient in 40-0-0-13 Urea-ES), Urea-ES products have the potential to save transportation and handling costs throughout the distribution chain, including for farmers. In addition, the product can offer farmers a convenient, all-in-one source of nitrogen and sulphur, with no blending required. At the farm level, sulphur-enhanced fertilizers have the potential to increase crop yield and improve crop quality by offering plants a more balanced nutrition.

Finally, Urea-ES may offer significant premium incentives solely based on current market nutrient pricing, as it could replace a potentially more expensive blend of urea and ammonium sulphate. For example, one tonne of Urea-ES 13S provides 400 kg N and 130 kg S. To provide the same amount of nutrients with traditional fertilizers, 0.62 t of urea and 0.54 t of ammonium sulphate must be used, a total of 1.16 t product. At January 2016 prices of \$301/t for urea and \$301/t for ammonium sulphate in the US cornbelt, one tonne of Urea-ES could supply a value corresponding to \$349 (estimated cost of 1.16 t of urea and ammonium sulphate blend, at \$301/t).

Urea-ES agronomy trials

Since 2014, Shell has been conducting agronomic trials with demonstration product on various crops and soil types across the globe. Results to date show equivalent and/or improved performance over straight urea applications, and other nitrogen and sulphur fertilisation programs.

A full laboratory and field-testing program commenced in 2014, with product made using drum granulation, to confirm the agronomic performance of sulphur-enhanced urea as compared to urea, urea ammonium sulphate mixtures, and sulphur bentonite urea mixtures (per farmer practices).

Some of the first tests performed were to determine oxidation performance in vari-

ous soils and conditions. Two independent groups of experts, in Europe and in the USA were employed to perform laboratory testing with multiple replications over a period of 60 and 120 days. The main findings were that the small particles of elemental sulphur in Urea-ES oxidise faster than the larger particles from other products such as sulphur bentonite. In addition, faster oxidation is achieved when Urea-ES is applied to the surface (broadcast application) and with effective granule disintegration (through rain/irrigation, or mechanical means to mix in the sulphur particles with the soil). In this last case, over 80% of the sulphur was oxidised from Urea-ES in a 25-day test, compared to less than 9% of the sulphur bentonite under the same conditions.

In the field, scientific trials have been undertaken with well-respected scientists and institutions in Brazil, Canada and the USA on corn, beans and canola (rape-seed). These trials compare various fertilizer treatments in small plots arrangement and with different soils.

Preliminary results show that, in terms of yield, Urea-ES products perform at least as well as other sulphur treatments, and can offer increased yields compared to the urea only (no sulphur) treatments in sulphur responsive soils. Although the Urea-ES results so far are statistically equivalent, as compared to other nitrogen and sulphur applications, in mixed and clay soils, some of the Urea-ES products are showing higher (3-4%) average yield over multiple plots. Furthermore, these equivalent yields were generally achieved using less Urea-ES fertilizer compared to the other product, creating a financial incentive to farmers to use a Urea-ES type of product. This comes back to the higher nutrient density of Urea-ES. Trials continue in the aforementioned countries and may expand into other regions in the future.

Finally, Shell has also engaged in semi-commercial trials in Western Canada and Brazil to provide farmers and retailers with hands-on experience with this fertilizer family.

Urea-ES vs other urea sulphur products

Until recently, there has been no commercially available technology for the production of a granular urea fertilizer containing elemental sulphur. The nitrogen sulphur fertilizers available on the market today are typically sulphur coated or contain mixtures of urea and ammonium sulphate (Table 1).

CONTENTS

What's in issue 341

COVER FEATURE 1

Long-term fertilizer demand

COVER FEATURE 2

Challenges for India

COVER FEATURE 3

Sulphur-enhanced urea

COVER FEATURE 4

Optimising catalytic reactors

NITROGEN+SYNGAS
ISSUE 341
MAY-JUNE 2016

BCInsight

Southbank House, Black Prince Road
London SE1 7SJ, England

Tel: +44 (0)20 7793 2567

Fax: +44 (0)20 7793 2577

Web: www.bcinsight.com
www.bcinsightsearch.com

Table 1: Comparison of urea sulphur fertilizer grades

	Nitrogen	Sulphur	N:S ratio	Sulphur source
Urea	46.3	-	-	
Urea + AS	45.6	0.36	-	UFT ACT plant (1.5% AS from NH ₃ scrubber)
Commercially available urea + sulphur fertilizers				
	40	5.5	7	with AS
	38	7.5	5	with AS
	33	12	3	with AS
Urea-ES grades				
Urea-ES 7S	43	7	6	with elemental sulphur
Urea-ES 10S	41.6	10	4	with elemental sulphur
Urea-ES 13S	40	13	3	with elemental sulphur
Urea-ES 24S	30	24	1.5	with elemental sulphur

The main purpose of coating urea with sulphur is to slow the release of urea, not to supply sulphur nutrition to the crop. While this product can contain a significant amount of elemental sulphur, it is unlikely to supply adequate sulphur nutrition to crops during the season of application, due to the fact that the elemental sulphur takes the form of a coating, and thus will oxidise more slowly than if it were in the form of fine particles.

Urea ammonium sulphate products can be produced by adding ammonium sulphate to urea solution as a solid or as a liquid. Both types of product are well established in the market. Solid ammonium sulphate must be processed before it can be incorporated into the urea fertilizer, by grinding the ammonium sulphate crystals into very small particles, which are then added to the urea melt. The inclusion of the ammonium sulphate crystals upsets the heat balance so that additional equipment is required for reheating the Urea/AS before feeding it into the granulation plant. Due to their hardness and their corrosive nature, the ammonium sulphate crystals can cause significant erosion and corrosion of piping and, of particular importance for a fluidised bed process, in the nozzles.

Due to the low critical relative humidity (CRH) of ammonium sulphate, the combined product also has a much lower CRH than that of granular urea fertilizer. This can lead to problems during production, storage and transport, particularly in humid regions. By comparison, elemental sulphur does not adsorb water/is not water soluble, and as such adding elemental sulphur to the urea does not affect the overall CRH.

The N:S ratio is an important consideration for nitrogen sulphur fertilizers, as

crops typically have recommended nitrogen and sulphur requirements. For most major crops that require nitrogen and sulphur, the N:S weight ratio ranges between 12:1 and 6:1 (data from IPNI Nutrient Removal Calculator and FAOSTAT, 2016). The ratio may be lower if the fertilizer will be used on sulphur-deficient soils, or if other nitrogen fertilizers will be blended in or applied separately. Table 1 shows a comparison of urea sulphur fertilizer grades.

Urea-ES fluid bed granulation process

The majority of large capacity urea granulation plants, which nowadays produce most of the granulated urea, are located in regions with an abundant and cheap supply of natural gas. In these regions, ammonium sulphate is not typically readily available and would have to be transported over large distances. Alternatively, urea producers could make their own ammonium sulphate, which would require a local ammonium sulphate production facility and, depending on the availability of sulphuric acid, a sulphuric acid plant. These additional facilities require a significant investment, which makes the large-scale production of urea fertilizer with

ammonium sulphate not feasible. Acidic scrubbers can produce small amounts of ammonium sulphate, but the amount is not sufficient to produce a significant amount of ammonium sulphate urea.

Fortunately, many urea granulation plants are located close to refineries and gas treating plants, which can provide an ample supply of elemental sulphur. In these regions, utilising this resource is likely to be the most cost efficient way to produce sulphur-enhanced urea.

As mentioned earlier, elemental sulphur is more likely to oxidise quickly when it is divided into fine particles (<150 µm). To provide a urea melt with finely divided sulphur, dry grinding of sulphur or procuring sulphur dust could be envisaged, however due to the explosive nature of sulphur dust, grinding the sulphur or handling large quantities of sulphur dust is not considered an option due to safety concerns.

An alternative is to melt the sulphur and mix it into the urea solution. However, due to the significant differences in density and surface tension (Table 2), a stable mixture of these two liquids cannot be achieved and does not produce homogeneous granules. As such, simply mixing molten sulphur into urea liquor results in visible segregation of sulphur

Table 2: Physical properties of sulphur and urea

	Urea	Sulphur
Melting point, °C	135	115
Density, kg/m ³	1215	1787
Surface tension, mPa s	2	8
Dust hazard	no, nuisance	yes, explosive



Pioneering with a higher purpose to enable the world to feed itself



If you have an existing urea plant, you may need to adapt to changes in legislation and market conditions. Stamicarbon can help you to stay compliant and competitive with a range of safe, cost-effective and environmentally friendly revamp schemes. Stamicarbon's range of EVOLVE services ensures your plant stays state-of-the-art.

For more information about our services, please visit: www.stamicarbon.com

The innovation & license company of Maire Tecnimont.



CONTENTS

What's in issue 341

COVER FEATURE 1

Long-term fertilizer demand

COVER FEATURE 2

Challenges for India

COVER FEATURE 3

Sulphur-enhanced urea

COVER FEATURE 4

Optimising catalytic reactors

NITROGEN+SYNGAS
ISSUE 341
MAY-JUNE 2016

BCInsight

Southbank House, Black Prince Road
London SE1 7SJ, England
Tel: +44 (0)20 7793 2567
Fax: +44 (0)20 7793 2577
Web: www.bcinsight.com
www.bcinsightsearch.com

Fig 1: Segregation of a urea sulphur solution upon solidification



Fig 2: Scanning electron microscopy of a 13% ES Urea-ES sample

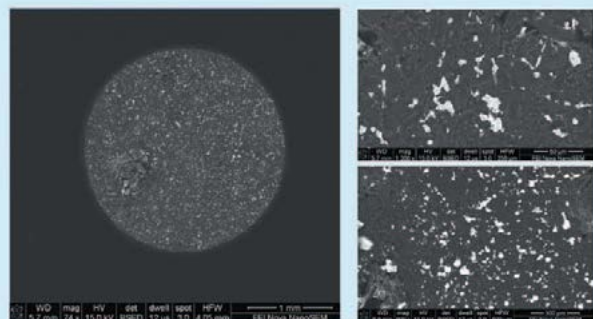

Test ID	Nitrogen			Sulphur			Buret
	Total	Ureic	Ammonical	Total	Sulphate	Elemental	
7-1126	40.4	-	-	13.4	-	-	0.8
Method	106um	75um	53um	38um	20um	Mean size um	Median size um
Particle size analyser	100	100	100	100	97.1	10.3	9.6
Sieve analysis	99.9	99.4	96.9	-	-		

and urea upon solidification, as shown in Fig. 1.

To circumvent the segregation of urea and sulphur, Shell's technology utilises a high shear dispersion unit (ThioMill) to efficiently disperse sulphur in the urea matrix, together with a proprietary additive (ThioAdd) to stabilise the emulsion. The additive also serves to bind the sulphur and urea during the solidification process. A similar segregation prevention principle underlies Shell Thiogro's ammonium phosphate fertilizer technology, which has been commercially installed and operated in regions around the world. The product of Shell's technology is a uniform and stable dispersion of sulphur particles in urea melt. The emulsion can be granulated to produce a sulphur-enhanced urea containing sulphur particles that are, on average, smaller than 40µm (Fig. 2).

Simplified process description

In order to produce Urea-ES, a supply of elemental sulphur and a sulphur handling system are required. For most locations, the sulphur will be available in solid form. This will require a sulphur unit consisting of sulphur bulk storage, a sulphur bulk handling system and a sulphur melter. The sulphur unit does not have to be located near the urea granulation plant. Sulphur melt can be piped, just like urea melt in heated piping. Due to the safety issues associated with sulphur dust, it is recommended to locate the sulphur-processing unit in a safe location and then pump the sulphur melt to the urea granulation plant.

The ThioAdd additive does not require any special safety requirements and can be handled in the same way as any other additive normally used in the urea granulation plant.

In the first step, the liquid sulphur is mixed with concentrated urea solution, the ThioAdd additive and any other optional additive for trace elements or anti-caking (Fig. 3). In the next step, the high-shear dispersion unit produces the sulphur/urea emulsion. From the dispersion unit, the sulphur/urea emulsion goes to the granulator spray nozzles. The spray nozzles used in a UFT fluidised bed plant are able to handle this emulsion without any modifications, and in the same range of operating conditions as used for urea production. Erosion in the nozzles is not a problem.

One significant difference between granulation of plain urea and granulation of a sulphur urea mixture is the processing of the dust from the fluidised bed plant. The Urea-ES dust, (e.g. in the off-gas from the granulator or fluid bed coolers) will contain sulphur. In a normal urea fluidised bed process, this dust would be captured in the dust scrubbers, dissolved and recycled to the evaporation unit of the upstream urea synthesis plant.

However, due to the sulphur content in the dust from Urea-ES, the recycling of the urea solution to the synthesis plant is not possible, as sulphur components in the recycle solution could contaminate the condensate from the evaporation unit, and from there the rest of the synthesis unit (HP synthesis and recirculation).

To avoid this contamination, a granulation plant producing Urea-ES will need a dedicated evaporation unit to process all the recycle streams from the urea fluidised bed granulation plant. The condensate from this small evaporation unit is solely used as make-up water for the dust scrubbers and is not returned to the synthesis plant or water treatment. UFT already uses similar evaporation units in plants, which utilise UFT's proprietary ACT ammonia emission reduction system.

While urea is fully water soluble, elemental sulphur is insoluble in water. Therefore, the dust scrubbers and their bleed must be modified so that they are able to handle a liquid/solid solution. This entails the elimination of "dead" zones where solids could accumulate, different pump impellers and an improved dust separation system in the scrubber. The horizontal crossflow scrubbers, already applied in new UFT urea fluid-bed granulation plants, are fully suitable for this service.

Principles of micronisation

Shell's "ThioMill" is a high shear/high speed rotor-stator dispersion mixer. It operates on a principle of impact and attrition, by

Fig 3: Basic flow sheet for a sulphur-enhanced urea granulation plant

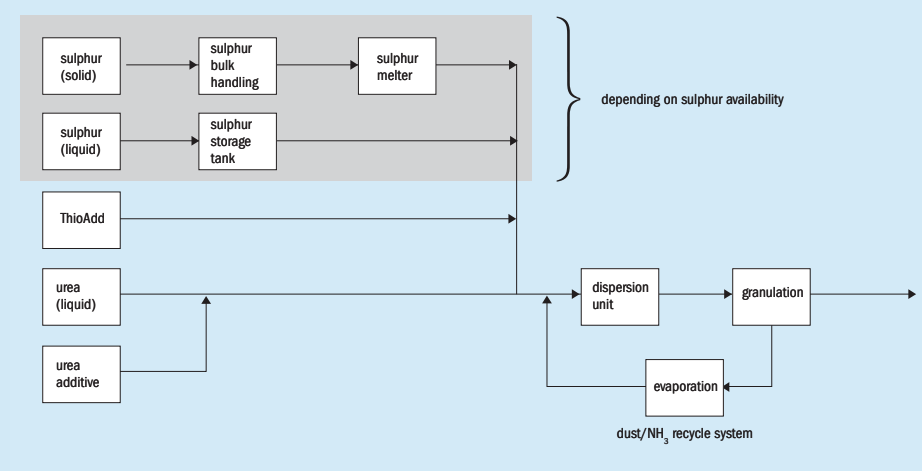

using a rotating dispersion head composed of a slotted rotor inside a slotted stator. The tip velocity, or speed of the fluid at the outside diameter of the rotor, is much higher than the velocity at the centre of the rotor. The shearing of the fluid is achieved by turbulence and rapid changes in local flow directions between the slots of the rotor and stator. These forces break up the sulphur melt into finely dispersed droplets.

An electric motor provides the energy required for shearing the liquids inside the mixer. The power requirement of the high shear dispersion mixer and the particle size distribution of the sulphur are a function of the desired particle size, the ThioAdd concentration and the mass flow of the emulsion.

The emulsion produced in the high shear dispersion mixer must be stabilised by the ThioAdd. The ThioAdd additive encapsulates the sulphur droplets to form discrete particles, enabling the dispersion of hydrophobic elemental sulphur within hydrophilic fertilizer matrix (urea melts/solutions). Without the ThioAdd, the emulsion is unstable and results in sulphur particles with an unsuitable size range.

Implementation in a UFT fluidised bed urea granulation plant

The UFT fluidised bed plant design has been proven to be extremely flexible and is used by more than 60 plants located in all climatic regions.

Shell and UFT are carrying out an extensive programme of trials in UFT's batch operated pilot plant to optimise the process conditions and product characteristics of Urea-ES. The primary objective of the tests is to prove that the plant operating conditions will not change significantly from current urea granule production.

The modifications required so that a UFT fluidised bed urea granulation plant can produce sulphur-enhanced urea are shown in Fig. 4.

For new or existing plants, the following additional units are required:

- sulphur dispersion unit (ThioMill);
- additive feed system (ThioAdd);
- recycle evaporation;
- sulphur feed system (upstream).

For existing plants, the following equipment must be investigated:

- Dust scrubber and recycle system (for urea/sulphur slurry);
- Bulk storage (additions for handling the new product).

The sulphur dispersion unit requires about the same space as the urea solution feed pump system.

The additional recycle evaporation is similar to the well-known evaporation unit used in all urea plants. As this unit reduces the load of the existing evaporation unit, the total steam consumption of the plant is not increased. An additional benefit of

this evaporation unit is that it gives the plant the added possibility to integrate the ammonium salt solution from acidic scrubbers in the urea synthesis and urea granulation plants into the Urea-ES solution and return it into the granulation process. This solves a common challenge for plants with NH₃ emission restrictions that have to find means to handle the ammonium salt produced by the acidic scrubbing systems.

The scrubbers should be modified to low pressure drop structured packing suitable for solid particles. Tray scrubbers will not be suitable due to the potential for solid accumulation in zones of low liquid flow. The use of impingement scrubbers, which are often used in small plants, has to be investigated. The modification of the impingement scrubbers to structured packing is possible and has the added benefit of reducing the pressure drop of the air system. For this application, Kimre (USA) and UFT have jointly developed a scrubber design suitable for the recovery of sulphur containing urea dust from the off-gas steams of a fluid bed urea granulation plant. This packing material has a high efficiency, a low pressure drop and is well established in NPK plants where insoluble components are also problematic.

One significant effect of the sulphur addition is that it reduces the heat input into the granulator. This is due to the significantly lower heat of crystallisation of the sulphur as compared to urea. As a result,

a lower amount of cooling air is required for the Urea-ES production. Depending on the Urea-ES grade, the production capacity of the granulator may be higher than for urea production.

For a new plant, this could reduce the specific investment costs of the granulation plant – in particular, the granulator, dust scrubber and the fluidisation air system would be smaller. This could, in turn, reduce the building size and required plot area.

In an existing granulation plant, a higher production capacity should be possible by utilising the design margins of the installed equipment. The additional evaporation system reduces the load of the existing evaporation system by eliminating the recycle stream from the granulation plant. Therefore, a higher urea feed solution flow is possible, if the existing evaporation unit is the limiting system.

If there is no additional urea production capacity, then the use of low-cost sulphur can reduce the operating costs of the product, while at the same time reducing the specific consumption of NH₃, CO₂ and natural gas. Excess NH₃ could alternatively

be sold to the market, e.g. a 2,000t/d granulation plant would require about 110 t/d less NH₃, when producing Urea-ES containing 10% sulphur.

In special cases, the excess urea solution could be used for other high value products, such as technical grade urea, UAN or DEF solutions.

Summary and outlook

Over the past several years, Shell has invested considerable resources into developing and investigating the use of micronised sulphur in fertilizers. These chemical, economic and agronomic investigations provide evidence of many potential benefits to producers and consumers of micronised elemental sulphur containing fertilizers, as compared to other sulphur fertilizers. Shell has developed an additive and a high shear-mixing unit to safely produce a stable sulphur/urea emulsion that can be processed in a fertilizer granulation plant.

In conjunction with Shell Thiogro technologies, UFT has modified its pilot plant

to demonstrate that the additional process steps and the urea/sulphur emulsion can be easily integrated into new or existing urea fluid bed granulation plants. Currently, the pilot plant is producing samples of various grades for large-scale agronomic tests and for assessment by interested parties. It is envisaged that small-scale industrial tests can be started in the near future.

Shell and UFT are confident that the development and production of Urea-ES can contribute to the improvement of soil conditions and balanced fertilisation, so that future agronomic output can be maintained or increased to help feed the world's growing population.

Acknowledgement

This article is based on the paper "An approach to innovation – UFT And Shell Thiogro sulphur-enhanced urea", by R. Garcia, C. Ingoldsbys and Dr. C. Allais of Shell Thiogro Technologies, and Dr H. Franzrahe of Uhde Fertilizer Technology, presented at Nitrogen+Syngas 2016 Conference, Berlin, Germany, 29 February – 3 March 2016.

Fig 4: Urea fluidised bed plant with modification for sulphur-enhanced urea

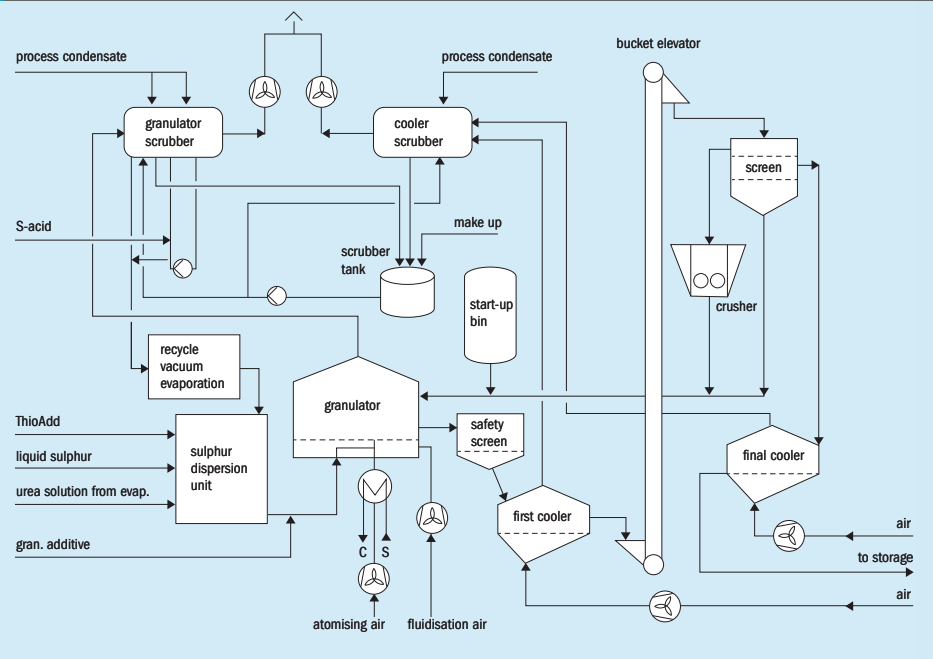

Urea+ fertilizer production

Over the last decade there has been a strong demand globally for fortified fertilizers to meet the nutrient demands of different soils and crops. Often nutrient requirements are specific to the region where the fertilizer is applied. Therefore, universal fertilizer technologies, which allow a wide range of fertilizers to be produced with a single unit have become popular. NIIK has developed and commercialised a universal urea+ fertilizers technology based on its high speed drum granulation (HSDG) technology and continues to develop it according to market demands. Since we first reported on the high speed drum granulation technology in *Nitrogen+Syngas No. 321*, numerous trials for the production of various urea+ fertilizer types have proved the high efficiency and flexibility of NIIK's HSDG technology.

To date, NIIK has designed three HSDG pilot units, each with a capacity of 100 kg/h (2.4 t/d), and two commercial units, each with a total capacity of 500 t/d using two drums of 250 t/d.

In Qatar, a pilot unit is currently in the commissioning stage for QAFCO for the production of urea with ammonium sulphate, with different ammonium sulphate contents in the finished product, and for urea with sulphur, including sulphur coated urea, a slow release fertilizer).

In Vietnam, a pilot unit started up in 2015 for Petrovietnam Fertilizer and Chemicals Co. for the production of urea-based fertilizers fortified with various nutrients such as N, K, S, B, Si, and Mg.

In Kazakhstan, a pilot unit was designed for KazAzot for the production of granulated ammonium nitrate of various types (porous AN, stabilised AN and water-resistant AN).

Based on the experience with pilot HSDG units commercial-scale HSDG units have been designed for KazAzot (Kazakhstan and Kemerovo Azot (Russia).

The Russian unit is being used for urea prill fattening to improve finished product quality. Finished product leaving the prill tower contains a lot of small prills (< 2 mm) which are being fattened in the downstream HSDG to improve quality their quality.

The commercial-scale HSDG unit at KazAzot is used for the granulation of high quality ammonium nitrate. The ammonium nitrate produced on the HSDG unit is strong, uniform and does not cake.

Key advantages of the HSDG unit for capacity enhancement of urea units and the production of urea-based fortified fertilizers include:

- small foot-print;
- easy to ship;
- advanced design;
- energy-efficient;
- wide range of fertilizers.

The HSDG technology can be used to produce value-added fertilizers and owing to the relatively low capex has a short pay-back period.



For the fertilizer and minerals industry

- Gravity or centrifugal discharge
- Outer double or central single chains with breaking loads up to 2,450 kN
- Lifting heights up to 90 m
- Conveying capacities exceeding 2,000 t/h
- Outstanding service life



AUMUND Fördertechnik GmbH
 Saalhofer Str. 17 • 47495 Rheinberg • Germany
 minerals@aumund.de • www.aumund.com



CONTENTS

What's in issue 341

COVER FEATURE 1

Long-term fertilizer demand

COVER FEATURE 2

Challenges for India

COVER FEATURE 3

Sulphur-enhanced urea

COVER FEATURE 4

Optimising catalytic reactors

NITROGEN+SYNGAS
ISSUE 341
 MAY-JUNE 2016

BCInsight

Southbank House, Black Prince Road
 London SE1 7SJ, England
 Tel: +44 (0)20 7793 2567
 Fax: +44 (0)20 7793 2577
 Web: www.bcinsight.com
 www.bcinsightsearch.com

An introduction to pre-reforming catalysis

J. Cross, G. Jones and M. A. Kent of Johnson Matthey Process Technologies discuss the catalysis behind pre-reforming in syngas plants. Pre-reforming can provide several benefits in modern hydrogen and ammonia plants including greater feedstock flexibility and improved energy efficiency.

Pre-reforming can be an advantageous step in modern hydrogen and ammonia plants. It is a stage in the syngas production process that takes place immediately upstream of the (primary) steam reforming furnace. It can improve energy efficiency and allows for increased feedstock flexibility¹. In some new plant designs a pre-reformer is used to reduce capital costs and, when retrofitted into existing plants, the step can allow for increased rate of production.

The pre-reforming stage can be thought of as an adiabatic hydrocarbon feedstock pre-treatment, which takes place at around 400°C to 550°C and pressures of up to 70 bar. The process gas is heated to these temperatures prior to the pre-reformer using heat from the primary reformer furnace duct (Fig. 1). Depending on the feedstock a re-heat may also be carried out after the pre-reforming step, also using heat from the primary reformer furnace duct.

Where hydrocarbons heavier than methane (higher hydrocarbons) are present, they are first steam reformed (equation 1) and then methanated (equation 2) in the presence of steam and hydrogen. Alongside methane, the gas exiting the pre-reformer contains hydrogen, carbon monoxide, carbon dioxide and steam; the ratios of which are dictated by the positions of the thermodynamic equilibrium of the methanation reaction (equation 2) and the water gas shift reaction (equation 3).

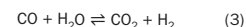

www.nitrogenandsyngas.com

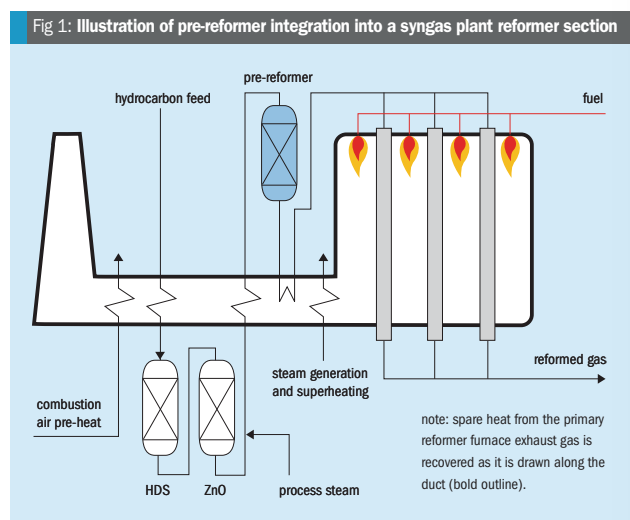

When the feed is methane or a light natural gas which contains only a small quantity of higher hydrocarbons, the overall reaction is endothermic and the temperature of the process stream falls as shown in Fig. 2a. When feeds containing significant quantities of higher hydrocarbons such as LPG, naphtha, heavy natural gas or refinery off-gases are pre-reformed, the overall reaction is exothermic and the temperature of the process stream rises overall. With the heaviest feeds, such as naphtha, there is an initial drop in temperature near the start of the bed as shown in Fig. 2b. The drop in temperature is due to the initial dominance of the endothermic steam reforming reactions.

The process stream that exits the pre-reformer essentially contains no hydrocarbons heavier than methane². This is of great benefit to the downstream process, particularly as methane is less susceptible to forming carbon deposits in the steam reformer tubes and heating coil compared to heavier hydrocarbons. Thus a process stream which has been pre-reformed can be heated to higher temperatures prior to the steam reformer than is possible in the absence of this step, enabling some of the advantages of installing a pre-reformer already described.

The pre-reforming reactions are catalysed by several metals including nickel, cobalt, platinum, palladium, iridium, ruthenium and rhodium³. Nickel is almost

Fig 2a: Typical bed temp. profile for natural gas pre-reforming

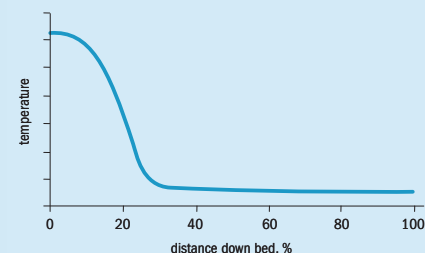
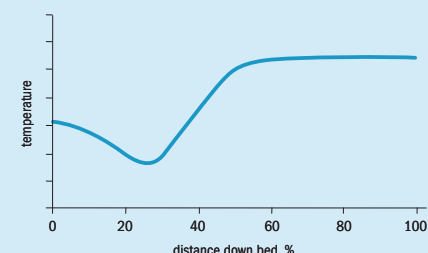

Fig 2b: Typical bed temp. profile for naphtha pre-reforming



always the metal of choice for pre-reforming because of its relative cost, high activity and stability in the metallic state at typical steam to hydrogen partial pressure ratios.

The active metals are typically dispersed on alumina or alkaline earth metal aluminate-based supports which offer sufficient chemical and thermal stability under reaction conditions. The support provides a structure to assist with the dispersion of the active metal to give small stable metal crystallites and hence a large metal surface area. This is important as the intrinsic activity of the catalyst is strongly influenced by active metal surface area. The support also influences the properties of the catalyst due to pore structure which is discussed later in this article. Operating temperatures are low in pre-reforming when compared to primary reforming. Very large nickel surface areas are therefore

required to ensure that the catalyst has sufficient activity. In Johnson Matthey's pre-reforming catalyst CRG LH the nickel surface area is in excess of 15 m² g_{cat}⁻¹, which is an order of magnitude higher than that found in most primary reforming catalysts. A comparison of primary reforming catalyst and pre-reforming catalyst design and operation is presented in Table 1.

Reaction mechanism and kinetics

The three key pre-reforming reactions are steam reforming, methanation (the reverse of the methane steam reforming reaction) and water gas shift, which dictates the CO to CO₂ ratio in the exit gas stream. Over the years there have been a number of reaction mechanisms proposed for the steam reforming of hydrocarbons on a nickel catalyst. These have been reviewed and combined into the

schematic illustration shown in Fig. 3, which illustrates how hydrogen, carbon monoxide and carbon dioxide can be formed from hydrocarbon and water^{3,4}. Also illustrated are potential routes to undesired polymeric gum and whisker carbon, which can lead to catalyst deactivation. This is discussed in more detail later. All of the reactions, except the hydrocarbon C-C bond cleavage reactions, are reversible but in this illustration the reactions have been indicated only in the forward direction for simplicity.

In this mechanism C_nH_y or CH₄ dissociatively chemisorbs onto the active site, with C₂₊ hydrocarbons decomposing via a series of C-C bond α-scissions, to give CH₃* and CH₂*. The remaining C-H bonds are successively cleaved to yield C*; a reactive carbon atom. In parallel to this H₂O dissociatively chemisorbs on an active site to give OH* then O*, which then

Table 1: A comparison of primary reforming catalyst and pre-reforming catalyst design and operation

	Primary reforming	Pre-reforming
Operating temperature	~500 to 850°C	~400 to 550°C
Heat transfer requirements	Essential that catalyst shape promotes turbulence and radial heat transfer. Complex shapes	Not required – operated adiabatically. Simple shapes unless low pressure drop required
Activation	Typically supplied oxidic	Typically supplied reduced and passivated – easy activation with high nickel surface area resulting
Nickel surface area	High. Typically 2 m ² g ⁻¹	Very high. CRG LH ~15 m ² g ⁻¹
Catalyst thermal stability	Very high	High
Promotion	Depends on duty. Catalyst often promoted to resist carbon formation	Sometimes promoted e.g. CRG LH promoted to resist polymer gum formation
Pressure drop	Low pressure drop desirable. Trade-off against heat transfer properties and geometric surface area	Low pressure drop desirable. Trade-off against geometric surface area

Nitrogen+Syngas 341 | May-June 2016

www.nitrogenandsyngas.com

CONTENTS

What's in issue 341

COVER FEATURE 1

Long-term fertilizer demand

COVER FEATURE 2

Challenges for India

COVER FEATURE 3

Sulphur-enhanced urea

COVER FEATURE 4

Optimising catalytic reactors

NITROGEN+SYNGAS
ISSUE 341
MAY-JUNE 2016

BCInsight

Southbank House, Black Prince Road
London SE1 7SJ, England

Tel: +44 (0)20 7793 2567

Fax: +44 (0)20 7793 2577

Web: www.bcinsight.com
www.bcinsightsearch.com

Fig 3: A possible reaction mechanism for steam reforming

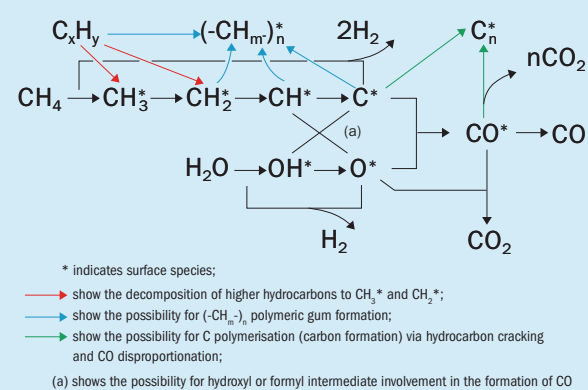

recombines with the C^* to give adsorbed CO^* . This can lead to gaseous CO and subsequently CO_2 through water gas shift (equation 3). Hydrogen is produced at various points through this mechanism as illustrated. For nickel-based catalysts under pre-reforming conditions, the rate determining step for methane steam reforming can be either CH_4 activation or C^* and O^* recombination depending on the operating conditions.

Observed rate of reaction

Whilst the intrinsic kinetics of the catalyst are important, the observed rate of reaction per unit volume in commercial pre-reforming is actually mass transfer limited (as the rates of pore diffusion are slow compared to the rates of the reactions which take place on the active metal surface).

This means that much of the conversion takes place near the surface of the pellet, and the catalyst's pore structure has a significant influence on observed activity. A higher rate of reaction per unit volume of catalysts bed can therefore often be achieved by using pellets with a smaller equivalent sphere diameter (i.e. the diameter of a sphere with an equivalent surface area to volume ratio of the object in question). Pellet size is therefore a trade-off between activity and the increased pressure drop over the catalyst bed which results from a decrease in pellet size (assuming the shape is unchanged).

Catalyst activation

Pre-reforming catalysts are typically supplied and charged into the pre-reformer in a reduced and passivated (surface-oxidised) form to enable easy in-situ activation and handling under air. After catalyst loading, start-up with a reduced and passivated catalyst will typically involve gradually heating the catalyst under a flow of nitrogen until it reaches operating temperature at which point hydrogen, steam and then process feed are added in order to bring the process online. The full start-up process can normally be carried out within 12 hours.

To manufacture a reduced and passivated catalyst, the catalyst is first reduced using hydrogen gas and high temperature. This process converts the nickel oxide in the catalyst to active elemental nickel according to equation 4, which is approximately thermo-neutral.

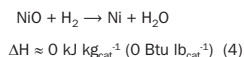

The reduction conditions are optimised to maximise the nickel surface area in the resulting product. At this point in the process the catalyst is pyrophoric (equation 5), so to enable safe transport and handling in air the catalyst is then partially re-oxidised to give a thin film of inert nickel oxide over the active nickel surface. This film can be easily re-reduced at low temperature to activate the catalyst.

Fig 4: a & b

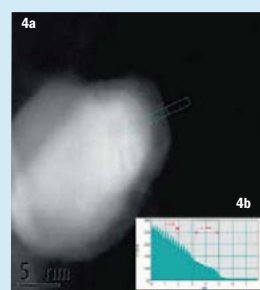

4a: A STEM high angle annular dark field (HAADF) image of a reduced and passivated nickel crystallite. 4b: A plot showing image intensities in the area of the HAADF image enclosed by the dotted lines.

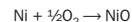

$$\Delta H \approx -1300 \text{ kJ kg}_{cat}^{-1} \text{ (559 Btu lb}_{cat}^{-1})}$$

in CRG LH (5)

Figure 4a is a scanning transmission electron microscope (STEM) high angle annular dark field (HAADF) image showing a reduced and passivated nickel crystallite. In this technique a beam of electrons is focused on a thin sample of powdered catalyst. The electrons are scattered predominantly by atoms with high atomic weight as they pass through the sample and are collected in a detector. Figure 4b is a plot of the intensities of the area in the HAADF image enclosed by the dotted lines. The 0-3 nm region of the intensity map shows high intensity and regular 0.2 nm spacing between the rows of Ni atoms which corresponds to a Ni $\langle 111 \rangle$ lattice spacing. The scattering pattern and intensity confirms that in this area the nickel is fully reduced. From 3-5 nm, the discontinuity in the scattering intensity drop off towards the edge of the particle permits this region to be assigned to the NiO passivation layer.

Reduced and passivated catalysts require lower temperature to fully reduce NiO to Ni compared to the equivalent oxidic catalyst. The ease of reduction of pre-reduced and passivated catalysts allows for easy catalyst activation in a plant pre-reformer. The ease of activation can be shown analytically by means of temperature programmed reduction, which is a technique that involves subjecting

Fig 5: Oxidic vs R&P catalysts

Typical temperature programmed reduction traces for oxidic and reduced and passivated (R&P) catalysts

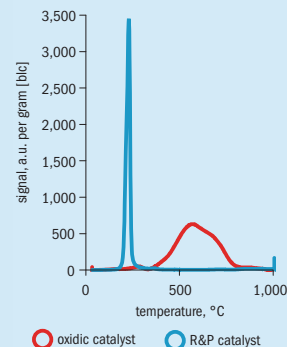

a sample to a programmed temperature rise whilst in a stream of hydrogen. Hydrogen consumption is measured using a thermal conductivity detector. Figure 5 compares the temperature programmed reduction profiles for an oxidic catalyst precursor and the corresponding reduced and passivated catalyst. The peak at 200 to 250°C in the reduced and passivated catalyst is due to hydrogen consumed by catalyst activation. The broad peak centred at around 550°C for the oxidic catalyst indicates that much higher temperatures are needed for its activation. High temperatures are required to reduce the nickel oxide in the oxidic catalyst due to the presence of strong nickel

Fig 6: Natural gas bed temperature profile

How the natural gas pre-reforming bed temperature profile typically changes due to deactivation by poisoning or sintering.

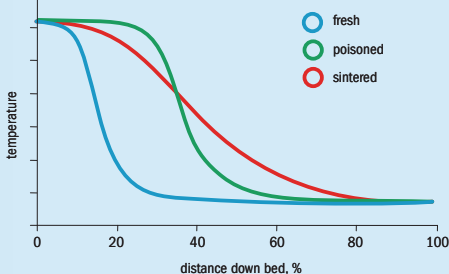

oxide-support interactions. The reduction temperature of the nickel oxide in the pre-reduced and passivated layer is similar to the reduction temperature of a sample of pure nickel oxide which suggests that the nickel oxide in the passivation layer resembles pure unsupported nickel oxide.

By comparing the peak areas it is possible to estimate that in this sample of reduced and passivated catalyst ~30% of the reduced nickel is reoxidised by the passivation process, which is consistent with the STEM image. Fully reduced nickel pre-reforming catalysts are pyrophoric when exposed to air. The extent of oxidation in passivated material ensures that it is safe to handle and transport the material, whilst making sure that catalyst re-reduction is a quick and easy process when installed in a pre-reformer.

Catalyst deactivation

The lifetime of pre-reforming catalysts is normally defined by when higher hydrocarbon slip starts to occur or by when pressure drop builds to a point where it is unsatisfactory. It is typically determined by one of four deactivation mechanisms: poisoning, thermal sintering, carbon laydown and oxidation⁶.

Poisoning and thermal sintering are more commonly life limiting when natural gas is the chosen plant feedstock, whereas for feedstocks containing significant quantities of C_3 , such as LPG and naphtha, carbon laydown can often be the limiting factor. Oxidation does not occur during normal operation but can occur during plant upsets if the $H_2O:H_2$ partial pressure ratio increases during a steam purge for example.

Changes in the composition of the gas stream exiting the pre-reformer cannot be observed until catalyst deactivation is at an advanced stage, so deactivation is typically monitored by tracking changes in the bed temperature profile. The nature of the temperature profile change can be used to diagnose which deactivation mechanism is dominant. This gives the plant operator the ability to adjust operating conditions to prolong the lifetime of the catalyst charge and also to predict when catalyst change out will be necessary before performance becomes unsatisfactory. The characteristic bed temperature profile changes caused by each type of deactivation are illustrated in Fig. 6 for natural gas/light feedstock pre-reforming and Fig. 7 for naphtha/heavy feedstock pre-reforming.

Compared to the fresh profiles, in the case of both natural gas/light feedstock pre-reforming and naphtha/heavy feedstock pre-reforming, poisoning gives rise to a flat temperature profile near the inlet caused by a major loss of activity near the start of the catalyst bed. In contrast to this, sintering causes the profile to become more relaxed due to partial loss of activity throughout the catalyst bed. In the case of polymer gum formation during naphtha/heavy feedstock pre-reforming, the initial endotherm becomes deeper. This deepening takes place because polymer gum formation causes the rate of exothermic methanation to decrease more than the rate of endothermic heavy hydrocarbon steam reforming. We recommend that operators seek assistance from their catalyst supplier to accurately interpret bed temperature profile movement for specific applications.

Fig 7: Naphtha bed temperature profile

How the naphtha pre-reforming bed temperature profile typically changes due to deactivation by poisoning, sintering or polymer gum formation.

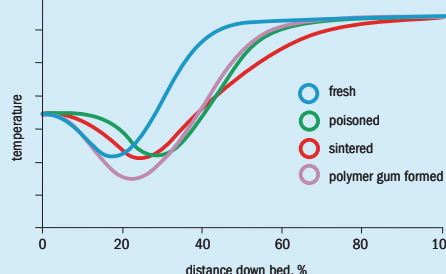
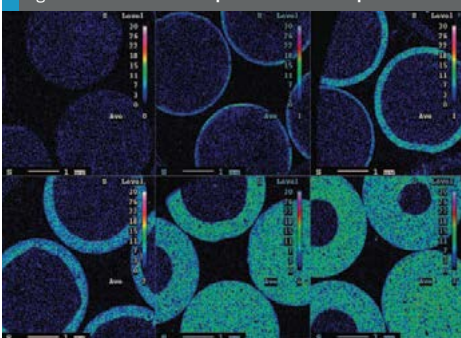

Fig 8: A series of EPMA sulphur distribution maps



Poisoning

There are many chemical species that are capable of poisoning pre-reforming catalysts. These include compounds of sulphur, halides, alkali metals, heavy metals and silica. The species that cause the biggest problem are sulphur compounds, which are present in all fossil fuel feedstocks in varying quantities. Hydrodesulphurisation (HDS) followed by zinc oxide hydrogen sulphide removal is the process normally used upstream of the pre-reformer to remove the vast majority of these sulphur species in order to protect the pre-reformer and other catalysts further downstream. For a higher level of purification a copper-zinc based ultra-purification process may be utilised. However, due to a combination of the kinetics and thermodynamics of sulphur removal reactions, and how the HDS and sulphur removal units are operated, it is inevitable that some sulphur species slip through. These species will progressively poison the pre-reforming catalyst through dissociative chemisorption on nickel and the catalyst bed therefore deactivates from inlet to exit. In cases involving a natural gas feedstock where sulphur poisoning is lifetime determining, a doubling of the sulphur content of the process stream entering the pre-reformer will approximately halve the expected lifespan of the catalyst charge.

Two factors are important in mitigating the impact of sulphur on the performance of the catalyst bed which are:

- the capacity of the catalyst to adsorb sulphur;
- the rate at which a catalyst adsorbs sulphur.

A high capacity to adsorb sulphur helps because if the catalyst at the start of bed has a high capacity for sulphur adsorption, the catalyst further down the bed is affected less as a result of a specific amount of sulphur introduced to the bed. The amount of sulphur a catalyst can adsorb under pre-reforming conditions is directly proportional to the nickel surface area, so the catalyst should have the highest possible nickel surface area under operating conditions.

The rate at which an individual pellet adsorbs sulphur before it becomes saturated also mitigates the impact of poisoning in a similar way. If a pellet approaches saturation quickly, this helps to protect catalyst pellets further down the bed from sulphur poisoning, which ensures that the overall pre-reformer catalyst charge performs adequately for as long as possible. To enhance the rate of sulphur adsorption the catalyst requires high porosity, which ensures that sulphur species can rapidly diffuse through the sulphidated shell of a partially poisoned catalyst to the unpoisoned nickel core. The choice of appropriate pellet porosity requires an appropriate understanding of the potential trade-off between diffusion and the active surface area.

Figure 8 shows a series of electron probe microanalyser (EPMA) sulphur distribution maps of cross sections of CRG LH catalyst pellets which have been exposed to varying quantities of sulphur whilst online in commercial pre-reformers. The maps show how sulphur slowly accumulates in pre-reforming catalysts from the surface of the pellet inwards, resulting in a shrinking core of active nickel.

As suggested by the observed shrinking core of active nickel, pellet geometric

Fig 9: Catalyst surface area vs sulphur deactivation rates

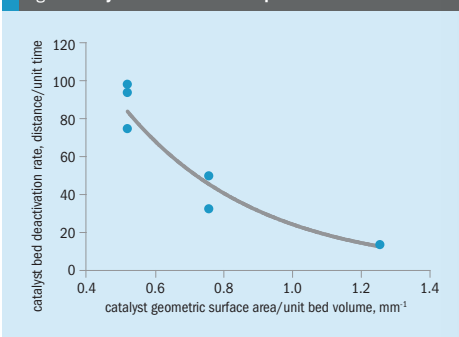

surface area (GSA) also affects rate of sulphur adsorption per unit volume of catalyst bed and this consequently affects the overall rate of bed deactivation. In the following study, small (3.1 mm diameter x 3.1 mm length), medium (5.4 mm diameter x 3.6 mm length) and large (9 mm diameter x 5 mm length) catalyst pellets were tested with parts per million (ppm) levels of sulphur in the feedstock. The bed deactivation rates for the three pellet sizes are shown in Fig. 9.

All charges were exposed to, and adsorbed, the same mass of sulphur. However the small pellets (high GSA) were much more effective at adsorbing sulphur than the larger pellets, hence the fraction of the bed that was influenced by the poison was smaller. Consequently the catalyst with lower geometric surface area deactivated much faster than can be explained by differences in available geometric surface area alone. Where sulphur is likely to be present at significant concentrations in the feed gas to the pre-reformer both the catalyst size and shape will be important in determining life.

The study of adsorption of sulphur on nickel catalysts and the impact that sulphur has on intrinsic activity has been an area of great debate in the academic literature. There is some inconsistency between reports on the capacity of the nickel crystallite surface for sulphur adsorption. Reports of the saturation coverage on the Ni(111) surface range from 0.25 monolayers (ML) to 0.5 ML (i.e. the number of sulphur atoms adsorbed per surface nickel atom)⁷. Recent investigations at Johnson Matthey using first-principles density functional theory (DFT) computational modelling have indicated that a 0.25 ML of sulphur is

Fig 10: Sulphur monolayers on a nickel surface

An optimised structure of 0.25 monolayers of sulphur in a nickel surface. The sulphur preferentially locates in a three-fold nickel coordination site. Green spheres = Ni, yellow spheres = S.

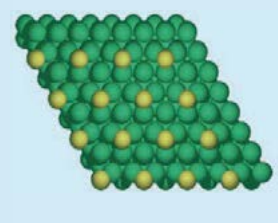

present on a sulphur-saturated nickel terrace surface under process conditions as illustrated in Fig. 10.

From the surface calculations it is possible to construct a first-principles adsorption isostere for sulphur (Fig. 11), which uses colour to indicate process gas conditions that give equivalent surface coverage. Good agreement for saturation coverage enthalpies and entropies of adsorption is found with the work of McCarty et al. [$\Delta H_{(800\text{ K})} = -145\text{ kJ mol}^{-1}$ (experimental results = $-155.2\text{ kJ mol}^{-1}$), $\Delta S_{(800\text{ K})} = +38\text{ J K}^{-1}\text{ mol}^{-1}$ (experimental results = $+35.9\text{ J K}^{-1}\text{ mol}^{-1}$)], which was carried out on real catalysts. This gives confidence in the conclusions drawn from the modelling work⁸. Figure 12 shows the calculated coverages of surface species for methane steam reforming in the presence of sulphur and the impact on intrinsic activity which is

Fig 11: Calculated isostere of sulphur

An isostere of sulphur calculated from first-principles. The colour indicates the degree of sulphur saturation (1 = fully saturated).

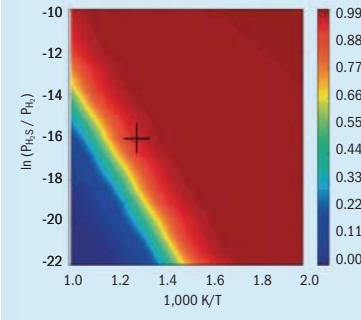

expressed as turn over frequency (TOF), the number of product molecules formed per active step site per unit time. The turn over frequencies were calculated through first principles DFT kinetic modelling of the steps in the reaction mechanism outlined in Fig. 3.

The isostere predicts that at a typical pre-reforming temperature of 500°C, with 10 ppb hydrogen sulphide in the process gas stream and a hydrogen content of 10%, sulphur will build up on the Ni terrace over a period of time until at equilibrium it will reach 90% of saturation level, as shown by the cross on Fig. 11. Figure 12 which was built using the coverage dependence for the active step sites in the model presented in reference 6, shows that a 50% drop in intrinsic activity is observed compared to the unpoisoned surface by the time we reach a hydrogen sulphide mole fraction of around 10 ppb. This estimate is based on a model where sulphur blocks the active sites. This is consistent with the catalyst's extremely high sensitivity to sulphur poisoning which is observed in real pre-reforming duty.

Sintering

Sintering is the process of particle agglomeration which occurs below the compound's melting point. The driving force for sintering is usually the minimisation of surface energy, i.e. a given mass of large particles has a lower surface energy than the same mass made up of small particles. In pre-reforming catalysts, sintering causes a reduction in the nickel surface area of the catalyst, which consequently causes a decrease in both catalytic activity

and resistance to sulphur poisoning. Three mechanisms have been proposed for how sintering can occur (Fig. 13):

- particle migration, which involves the movement of whole crystallites leading to agglomeration;
- atom migration (Ostwald ripening) which involves the net transfer of atoms from small crystallites to large crystallites along the support surface eventually leading to disappearance of the smaller crystallite;
- vapour phase transport of metal species between particles, which again leads to the disappearance of smaller crystallites over time⁹.

Particle migration is suggested to be the dominant mechanism under pre-reforming conditions.

The rate of nickel sintering is primarily affected by process temperature and gas composition with high steam partial pressure accelerating the rate of sintering. The surface chemistry and morphology of the catalyst also affect the rate of sintering to some degree; both can be optimised during catalyst design.

Figure 14 shows an SEM image of the needle like morphology of CRG LH catalyst at high magnification. The high surface area of the support helps to slow the rate of sintering.

One method of assessing a catalyst's resistance to sintering is to carry out long term pre-reforming tests where movement in the catalyst bed temperature profile is monitored over time to look for the effects shown by Fig. 6. The plot shown in Fig. 15 shows a 1000 hour test where CRG LH

Fig 12: Calculated TOF and coverages of surface species

Calculated turn over frequency (TOF) and coverages (θ) of surface species for methane steam reforming in the presence of sulphur under typical pre-reforming conditions (500°C, 25 bar). Note $\theta^* =$ vacant site, $x = 0-3$, $y = 0-1$

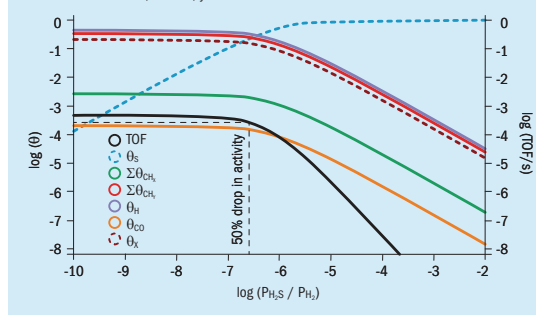

CONTENTS

What's in issue 341

COVER FEATURE 1

Long-term fertilizer demand

COVER FEATURE 2

Challenges for India

COVER FEATURE 3

Sulphur-enhanced urea

COVER FEATURE 4

Optimising catalytic reactors

NITROGEN+SYNGAS
ISSUE 341
MAY-JUNE 2016

BCInsight

Southbank House, Black Prince Road
London SE1 7SJ, England

Tel: +44 (0)20 7793 2567

Fax: +44 (0)20 7793 2577

Web: www.bcinsight.com

www.bcinsightsearch.com

was used to pre-reform de-sulphurised natural gas at an inlet temperature of 600°C, a pressure of 24 bara and a steam to natural gas flow ratio of 1 on a mass basis. The temperature profile shows minimal movement over the duration of the test, illustrating the high stability of CRG LH under these conditions. This result was supported by that fact that the conversion of the ethane component of the natural gas was >99.8% for the duration of the test. Note: ethane conversion is used as a measure of catalyst activity as this is the most abundant reactant in natural gas which is not also formed by any of the reversible reactions in the pre-reformer.

Carbon laydown

Carbon laydown is a major deactivation mechanism for pre-reforming catalysts, particularly when processing heavier feedstock such as naphtha or when running at low steam to carbon ratios¹⁰. The catalysts are typically promoted with potassium-containing compounds to avoid this problem. There are two different types of carbon laydown that cause issues. These are:

- polymeric gum, which occurs when the pre-reformer temperature is too low;
- whisker carbon, which occurs via hydrocarbon cracking when the temperature is too high.

The pre-reformer must therefore be run in a specific temperature window to remain carbon free, with the position of the window depending on factors including the feedstock composition, the amount of steam used, the system pressure and the catalyst selectivity.

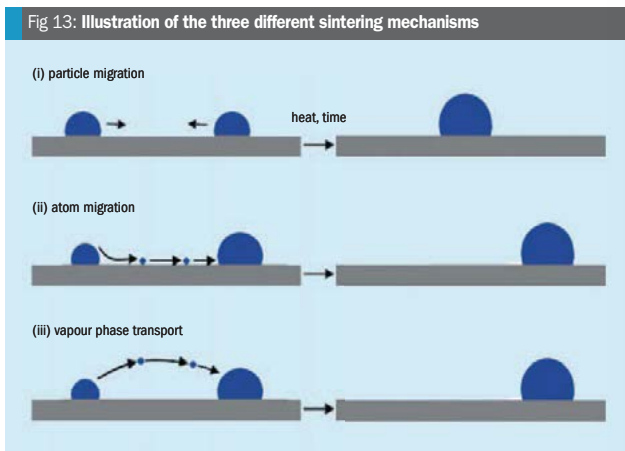

Under aggressive pre-reforming conditions whisker carbon may form via hydrocarbon cracking reactions (6). This reaction leads to adsorbed carbon atoms on the surface of nickel crystallites that, under certain conditions when the rate of hydrocarbon cracking is fast compared to the rate of steam gasification of carbon (high temperature, low steam partial pressure, high hydrocarbon concentrations), may lead to carbon whisker growth of the type shown in Fig. 16 and Fig. 17 at the crystallite/support interface. This whisker growth subsequently causes the nickel crystallite to lift away from the surface of the support and can cause mechanical breakage of the catalyst pellets. As the active metal surface is still exposed to the gas atmosphere, the catalyst does

not deactivate and whisker carbon growth will continue unless the process conditions are changed, eventually leading to pellet breakage and increased pressure drop.



Polymeric gum, as shown in Fig. 18, is formed by polymerisation of hydrocarbons on the nickel surface which is illustrated mechanistically in Fig. 3. This problem is much more common when the feed contains significant quantities of higher (C₃₊) hydrocarbons. The chemical structure of the gum can range from (-CH₂)_n to polymerised aromatics depending on the degree of dehydrogenation. As this type of carbon encapsulates the active nickel it deactivates the catalyst through inhibition of mass transfer to the active surface.

Fig 14: Scanning electron microscopy image of CRG LH

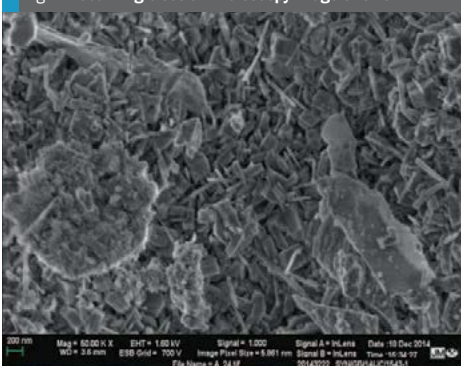
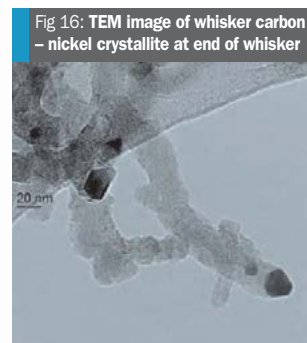
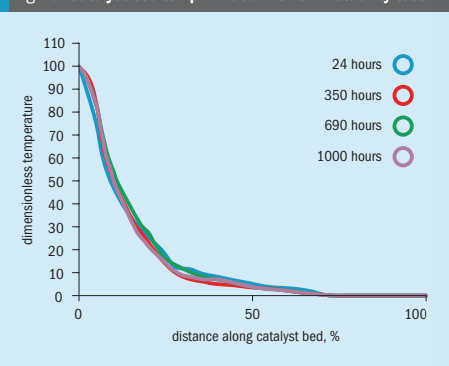

Fig 15: Catalyst bed temp in 1000 h CRG LH stability test



Using DFT modelling, Johnson Matthey has studied at the atomic scale the initial formation and nucleation of the problematic carbon. The promoted and unpromoted gasification of carbon using oxygen based species has also been studied.

Figure 19 illustrates (i) the nucleation of carbon (grey spheres) at step edge or defect nickel (green spheres) sites, (ii) growth of carbon from the step edge to form a graphene-like layer which spreads along the terraces and (iii) the reaction of graphene-like carbon with OH (red and white spheres) adsorbed on a terrace site, causing gasification of the carbon. Further computational work has been completed to consider new ways to promote the gasification of carbon as the pragmatic route to reduce this issue further.

The hydrogen produced by the reactions in the steam reformer ensures that reducing conditions are always present in normal service, but in abnormal service, such as a plant trip event which leads to a steam purge, nickel based pre-reforming catalysts can be deactivated by oxidation

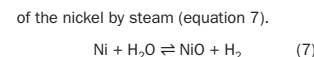

of the nickel by steam (equation 7). Metallic nickel (e.g. nickel foil) is stable with respect to oxidation with just 0.3-0.6% (v/v) hydrogen in steam. However, for nickel-based pre-reforming catalysts, support interactions and crystallite size effects influence the thermodynamics of nickel oxidation which mean in practice 6-8% (v/v) hydrogen is required in steam to ensure that the catalyst stays in the active, reduced state^{3,11}. If steam-based oxidation does occur, re-reduction does not lead to full recovery of activity as oxidation-reduction cycles promote catalyst sintering. Full re-reduction can also be difficult to achieve due to interaction between the nickel oxide and the support.

To illustrate this deactivation mechanism, a plant trip was simulated in a test reactor mimicking conditions where a bed of pre-reforming catalyst is exposed to a steam-only environment whilst the system is gradually depressurised. The test involved natural gas pre-reforming at 35



barg with appropriate catalyst dilution to ensure that the ethane component of the natural gas was not completely converted to C1 species. This gives a measure of catalyst activity by assessing differences in natural gas ethane conversion over time in the test.

The test was divided into four phases:

- 0 to 18 hours, an assessment of ethane conversion at 600°C and 500°C wall temperature when fresh;
- 18 to 38 hours, an accelerated ageing period with elevated temperatures for 20 hours;
- 38 to 62 hours, an assessment of aged ethane conversion at 600°C and 500°C wall temperature, and;
- 62 to 134 hours, three, one-hour pure steam exposures at 64, 88 and 112 hours online with subsequent ethane conversion measurement. During the steam exposures the rig was gradually depressurised from 35 to 14 barg to simulate this class of plant trip.

The results of the test are illustrated in Fig. 20, which shows a plot of ethane con-

Fig 19: Computational model of carbon laydown and removal

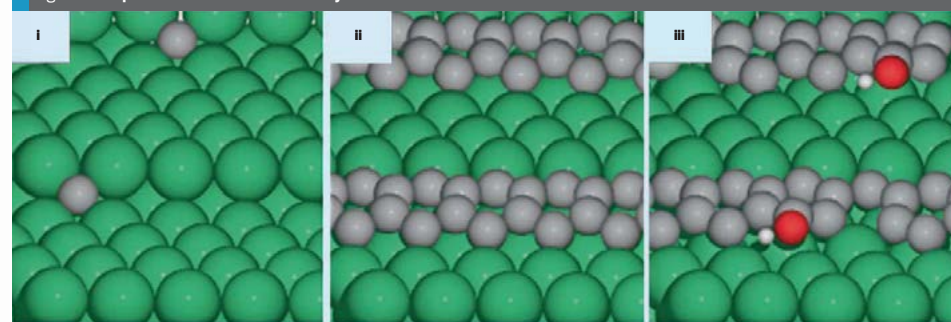
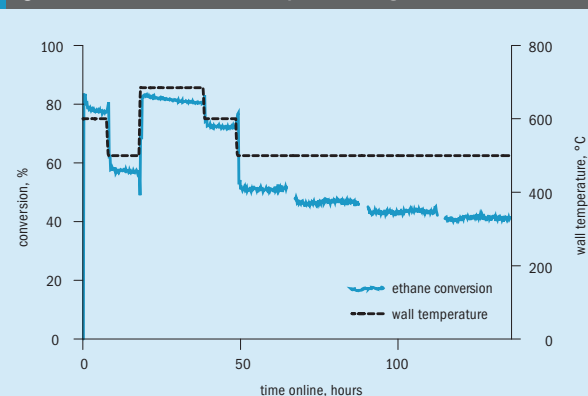

Fig 20: Ethane conversion vs wall temperature during oxidation test



version and reactor temperature measured on the wall on the vessel.

The results from this test show that ethane conversion drops from 51% to 41% over three, one-hour steaming events. No gradual recovery in activity is observed when the plant is returned to normal operating conditions after each steaming incident. This result illustrates why it is essential that, in the event of a plant trip where the pre-reforming catalyst is exposed to a steam-only environment, reducing conditions (e.g. standard pre-reforming conditions) are re-established as quickly as possible. Further work has shown that if the catalyst is subject to optimal reduction conditions after steaming (typically dry hydrogen); approximately half of the lost activity can be recovered. Typically operators are advised that pre-reforming catalyst should not be kept at temperature and at full system pressure in a steam only environment for more than 15 minutes. If the plant usually starts to depressurise with forward flow, such that the steam partial pressure is decreasing with time, then a longer time period may be acceptable.

Conclusion

The addition of a pre-reformer to a hydrogen or ammonia plant can provide a simple, compact and cost effective means of increasing plant efficiency or plant rate. The pre-reforming process increases feedstock flexibility, permitting feedstocks ranging from natural gas and refinery off-gases

through to heavy naphtha to be used interchangeably.

The pre-reforming reaction pathways on the catalytically active nickel surface involve hydrocarbon and steam decomposition to give adsorbed carbon and oxygen atoms which recombine to give carbon oxides. In the case of the methane reforming reaction, the intrinsic reaction rate on the active metal surface is determined by both hydrocarbon decomposition and C* and O* recombination as both have similar reaction barriers. However, the observed reaction rate in the pre-reformer is limited by pore diffusion, meaning catalysts are designed as highly porous pellets with high bed geometric surface area.

The catalyst is typically supplied reduced and passivated to enable easy catalyst activation in the pre-reformer. In the reduction and passivation process the catalyst is first reduced using hydrogen gas and high temperature. This converts the nickel oxide in the catalyst to active elemental nickel. The catalyst is then partially re-oxidised to give a thin film of inert nickel oxide over the active nickel surface to enable safe handling in air. This film can be easily reduced at low temperature to activate the catalyst.

In plants which use natural gas or other light refinery off-gases as feedstocks the lifetime of the pre-reformer catalyst charge tends to be limited by either thermal sintering of the nickel-based catalyst or the rate of sulphur poisoning, which causes progressive deactivation along the pre-reformer catalyst bed. In

plants which use heavier feedstocks such as naphtha, lifetime is frequently limited by the rate of polymeric gum formation. Through understanding the science of pre-reforming technology, reactions, kinetics, activation and deactivation, a plant operator can reliably manage the lifetime of a pre-reformer charge whilst allowing higher hydrogen production rate or efficiency in the syngas plant.

References

- Littlewood S., Gamlin T. and Linthwaite M.: 'Prereforming: Based on high-activity catalysts to meet market demands', *Ammonia Plant Safety & Related Facilities (AIChE)*, 2000, 40, 3
- Lloyd L. *Handbook of Industrial Catalysts*, Springer, New York, 373-374 (2011).
- Twigg M.V. (ed.), *Catalyst Handbook* Second Edition, Manson Publishing Ltd., London (1989).
- (i) Xu J. and Froment G.F., *AIChE J.*, 35, 88-96 (1989); (ii) Hou K. and Hughes R., *Chem. Eng. J.*, 82, 311-328 (2001); (iii) Froment G.F. and Fowles M., unpublished work; (iv) Rostrup-Nielsen J.R., *J. Catal.*, 31, 173-199 (1973).
- Jones G., Jakobsen J.G., Shim S.S., Kleis J., Andersson M.P., Rossmel J., Abild-Pedersen F., Bligaard T., Helveg T.S., Hinnemann B., Rostrup-Nielsen J.R., Chorkendorff I., Sehested J. and Nørskov J.K., *J. Catal.*, 259, 147-160 (2008).
- Bartholomew C.H., *Appl. Catal. A: Gen.*, 212, 17-60 (2001).
- (i) Lüdecke J., Ettema A.R.H.F., Driver S.M., Scragg G., Kerker M., Woodruff D.P., Cowie B.C.C., Jones R.G. and Bastow S., *Surf. Sci.*, 366, 260-274 (1996); (ii) Perdureau M. and Oudar J., *Surf. Sci.*, 20, 80-98 (1970); (iii) Monder D.S. and Karan K., *J. Phys. Chem. C*, 114, 22597-22602 (2010); (iv) Eley D.D., Pines H. and Weisz P.B. (eds.) *Advances in catalysis*, volume 31, Elsevier Inc., Amsterdam (1982).
- McCarty J.G. and Wise H., *J. Chem. Phys.*, 72, 6332-6337 (1980).
- Sehested J., Gelten J.A.P., Remediakis I.N., Bengaard H. and Nørskov J.K., *J. Catal.*, 223, 432-443 (2004).
- Sperle T., Chen D., Lødeng R. and Holmen A., *Appl. Catal. A: Gen.*, 282, 195-204 (2005); (ii) Christensen T.S., *Appl. Catal. A: Gen.*, 138, 285-309 (1996); (iii) Snoeck J.-W., Froment G.F. and Fowles M., *J. Catal.*, 169, 250-262 (1997); (iv) Snoeck J.-W., Froment G.F. and Fowles M., *J. Catal.*, 169, 240-249 (1997).
- Rostrup-Nielsen J.R., Anderson M. (ed.), Boudart J.R. (ed.), Chapter 1, *Catalytic Steam Reforming*, in: *Catalysis: Science and Technology V*, Anon., Springer, Berlin, 1-117 (1984).

5th

Syngas | Ammonia | Urea | Nitrates | Methanol | GTL | Hydrogen



Asian Nitrogen + Syngas 2016

21-23 November 2016
Shangri-La Hotel, Jakarta, Indonesia

Promoting and developing best practice and innovation in the Asian nitrogen industry

5 reasons to attend Asian Nitrogen + Syngas 2016:

- ✓ **Develop** practical solutions to operational problems through detailed case-studies, training-led workshops and interactive clinics
- ✓ **Learn** about the latest technological and process innovations
- ✓ **Share** best practice operational experience with peers
- ✓ **Understand** the supply and demand dynamics shaping global markets
- ✓ **Network** with 200+ technical peers from the Asian nitrogen industry and beyond

“ Such a good conference, not only for new knowledge but also new networking. I am eager to attend this tremendous seminar again. ”

Process Engineer,
PT Petrokimia Gresik

Past delegates include senior technical representatives from:

Abu Qir Fertilizers Company • ASEAN Bintulu Fertilizer Sdn Bhd • Ashuganj Fertilizer & Chemical Company Ltd • Ballance Agri-Nutrients • Brunei Methanol Company • CSBP • Farg'onaazot JSC • Fauji Fertilizer Co.Ltd • FERTIL • PT Kaltim Parna Industri • KAFCO • LyondellBasell • Navoiyazot JSC • OCI Kaltim Melamine • Omifco • Orica • Pardis Petrochemical Company • Petro Vietnam • Petrokimia Gresik • Petronas • PT Multi Nitrotama Kimia • PT Panca Amara Utama • Persero • PT Pupuk Iskandar Muda • Pupuk Kaltim • Pupuk Kujang • Pupuk Sriwidjaja • Queensland Nitrates Pty Ltd • Rashtriya Chemicals and Fertilizers Limited • Saudi International Petrochemical Company • Zagros Petrochemical Company

SPONSORSHIP AND EXHIBITION OPPORTUNITIES

DON'T MISS OUT!

THE EXHIBITION IS NOW 75% SOLD WITH THE LAST FEW STANDS REMAINING

Take advantage of an exhibition stand to promote your products and services to a significant number of plant operators from the region – with over 50% of the audience from fertilizer production companies.

This is a valuable opportunity to build new and existing working relationships with a large audience of producers.

For more information on available stands, past attendee lists and sponsorship opportunities, please contact:
michelle.fisk@crugroup.com

A limited number of presentation opportunities are also available, contact:
amanda.whicher@crugroup.com

CONTENTS

What's in issue 341

COVER FEATURE 1

Long-term fertilizer demand

COVER FEATURE 2

Challenges for India

COVER FEATURE 3

Sulphur-enhanced urea

COVER FEATURE 4

Optimising catalytic reactors

NITROGEN+SYNGAS
ISSUE 341
MAY-JUNE 2016

BCInsight

Southbank House, Black Prince Road
London SE1 7SJ, England

Tel: +44 (0)20 7793 2567

Fax: +44 (0)20 7793 2577

Web: www.bcinsight.com
www.bcinsightsearch.com



Register today at www.nitrogenasia.com

Optimising catalytic reactors in ammonia plants

Advances in simulation and analysis tools are being used to improve the design of catalytic reactors in ammonia plants. Improving the catalyst efficiency and reducing the front-end pressure drop (ΔP) in ammonia plants are well known to reduce operating costs by decreasing the energy consumption and increasing production. Technologies aimed at reducing the ΔP across catalytic reactors include altering internals and loading low pressure drop catalysts.

Fig 1: Ammonia front end catalyst ΔP

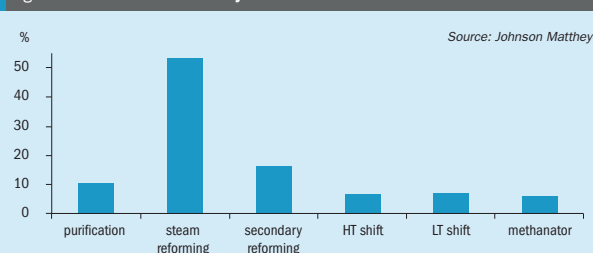

To fully understand the potential benefits available through the application of improved reactor designs, an appreciation of the flowsheet is required. Considering the front end of a standard, natural gas-fed ammonia plant flowsheet, the feed is purified and undergoes the steam reforming reaction and secondary reforming with air to form a mixture of hydrogen, nitrogen, carbon monoxide, carbon dioxide and residual methane. The water gas shift reaction (high and low temperature) produces hydrogen and converts the carbon monoxide to carbon dioxide, which is then removed, most commonly by a liquid absorption system). The ammonia synthesis catalyst is poisoned by oxygenate species, hence the carbon oxides in the synthesis gas are passed through the methanator to convert them to

methane. The resultant gas is a mixture of hydrogen and nitrogen with traces of inert species that is further compressed before being fed to the ammonia synthesis loop.

Figure 1 shows the distribution of pressure drop over the front end of a typical natural gas-fed ammonia plant. The total pressure drop over the front end of the plant is generally in the range of 10-17 bar and the catalytic units account for 35-45% of this.

From Fig. 1 it can be seen that the largest proportion of the pressure drop across the front end is encountered in the primary reformer. The primary reformer is a complex, multi-parallel tube process and a certain amount of pressure drop can be seen as necessary across the inlet and exit headers to ensure even flow through the tubes. Additionally, pressure drop through

the catalyst tubes is beneficial to promote the high heat and mass transfer required to drive the strongly endothermic reforming reaction towards equilibrium.

Considering the complete flowsheet there are many stages involved in the transition from feedstock to product and ample opportunity to achieve pressure drop benefits across all of the catalytic units, including packed bed catalytic reactors. Whilst pressure drop cannot be completely eliminated, and a certain amount is required to give good distribution through a packed catalyst bed, it can be minimised through the use of modelling and creative design of equipment and catalysts.

Pressure drop and plant efficiency

Many older generation plants are able to operate well above their original name plate capacity using their existing hardware. An undesired side effect of this is often high pressure drop due to increased flow rate (f) through the existing equipment, with pressure drop increasing at a rate relating to (f)². Reduction of the pressure drop across the front end of an ammonia plant can be beneficial due to the reduction in duty of the synthesis gas compressor (or increase in capacity) from a higher suction pressure. As an example, for a typical ammonia plant, a 0.1 bar reduction in front end pressure drop could result in a power saving of around 20 kW, or for the same compressor duty, an increase in ammonia

production of around 1 t/d. In addition, if the process air compressor throughput limits the plant capacity, a decrease in downstream pressure drop will ease the restriction and may allow the production rate to be increased.

Johnson Matthey technologies for reduced pressure drop

Johnson Matthey offers a wide range of innovative solutions to reduce pressure drop ranging from simple changes to catalyst loadings for smaller pressure drop reductions through to new vessel internals for more significant pressure drop reductions and maximising efficiency across the syn-gas plant flowsheet. The examples in this article relate to the ammonia flowsheet, however most of these technologies are equally applicable across methanol and hydrogen flowsheets.

Steam reforming of natural gas

The primary reformer is at the heart of any ammonia plant, it represents the largest capital expenditure unit operation and is the largest energy consumer within the process. The reforming reactions of methane and higher hydrocarbons are strongly endothermic, and as such require a large amount of heat input and high temperatures to achieve the desired conversion of natural gas to hydrogen. Although lower pressures are desirable from an equilibrium perspective, economically it is preferable to operate at higher pressures. This being the case, an obvious area of focus when improving reforming efficiency is chemical reaction facilitation, through:

- improved heat transfer (to improve both the kinetics and the equilibrium conversion, whilst potentially reducing the reforming fuel requirements);
- alternative reaction pathway with a lower activation energy (i.e. catalysis); and
- reduced pressure drop (to improve the reaction kinetics).

The overall pressure drop across a steam reformer is a combination of:

- distribution of the process gas across a multitude of catalyst tubes;
- steam reforming catalyst;
- catalyst support grid;
- re-collection of process gas to a single stream.

Johnson Matthey has demonstrable experience in reforming technologies

and their application in improving plant performance, often achieving a 15-20% decrease in pressure drop across the reforming catalyst.

Steam reforming catalysts

The selection of catalyst for the steam reforming duty is critical to ensure optimum performance of the equipment and to prevent operational issues such as carbon formation within the catalyst tubes.

The QUADRALOBE™ shape of Johnson Matthey's steam reforming catalyst pellets has been purposely designed to combine high strength and activity with low pressure drop. This specially designed shape is available in a range of sizes and catalyst types to allow the activity and pressure drop of the catalyst offering to be tailored to each individual customer's needs.

For example, the large shape XQ delivers lower pressure drop and the small MQ shape provides an activity boost. Depending on the individual plant's requirements, the high activity MQ shape could be used as a top layer to provide high activity at the top of the tube, where it is needed most. The lower catalyst layer could be XQ shape to reduce the pressure drop across the tube and help provide efficiency benefits to the customer. Another benefit of the high activity catalyst is the ability of the operator to reduce the steam to carbon ratio in the reformer feed. This will reduce both process steam consumption and pressure drop, due to the lower total process gas flow through the system. Optimisation of the steam reformer catalyst loading is a simple and effective way to boost plant efficiency.

Reformer retube

Within the reformer furnace the steam reforming reaction takes place over catalyst within a multitude of metal tubes. Due to the necessary harsh operating conditions within the furnace, the tube integrity deteriorates over time, and as such they require replacement to maintain or improve operational efficiency.

In addition to catalyst changes, Johnson Matthey is ideally placed to aid operators with the task of retubing the reformer. The retubing process provides an opportunity to use an improved tube metallurgy which in turn allows thinner walled tubes with larger inner diameters to be used, offering lower pressure drop. Retubing typically occurs on >15 year frequency and is usually an unfamiliar task for the plant,

hence working with someone with years of experience of similar activities can be particularly helpful, especially when they bring an un-paralleled experience in design and operation of steam reformers and can determine the effect of re-tubing on downstream and associated unit operations.

Johnson Matthey's in-house PRIMARY software combines knowledge of chemical reaction kinetics and equilibrium, combustion, heat transfer, pressure drop and reformer tube design parameters with optimisation algorithms for high-level design and analysis of reformer tube performance, providing key information on how best to design or optimise processing conditions to get the most from the reformer. Alongside this, PRIMARY will allow further optimisation through selection of the best catalyst choice from Johnson Matthey's range of reforming catalyst products.

Johnson Matthey Process Technologies is able to offer a complete package of project support and advice for operators wishing to retube their reformer, including:

- initial performance predictions;
- scoping;
- full revamp studies;
- design engineering;
- procurement and inspection of replacement tubes;
- overhaul planning and installation.

This wide range of services utilises Johnson Matthey's detailed knowledge around primary reformers and synthesis gas generation plants. A full reformer retube is an opportunity for an operator to combine a routine tube change with a simple, effective plant upgrade to reduce pressure drop and improve efficiency.

CATACEL_{SM} SSR™

For operators who are looking for a change in catalyst to obtain significant operational efficiency improvements, Johnson Matthey's new structured stackable catalyst could provide the answer. CATACEL_{SM} SSR is an innovative technology, which allows unique and unrivalled combinations of heat transfer, reactive surface area and pressure drop characteristics to be made available within tubular steam reformers. These enhanced catalyst performance parameters can be tailored and targeted for each steam reforming plant such that the maximum operational benefit is realised both for operators of existing plants and for new steam reformer designs.

CONTENTS

What's in issue 341

COVER FEATURE 1

Long-term fertilizer demand

COVER FEATURE 2

Challenges for India

COVER FEATURE 3

Sulphur-enhanced urea

COVER FEATURE 4

Optimising catalytic reactors

NITROGEN+SYNGAS
ISSUE 341
MAY-JUNE 2016

BCInsight

Southbank House, Black Prince Road
London SE1 7SJ, England

Tel: +44 (0)20 7793 2567

Fax: +44 (0)20 7793 2577

Web: www.bcinsight.com
www.bcinsightsearch.com

CATACEL_{SM} SSR is designed to leverage the high voidage, high geometric surface area and controlled gas flow that is available in a structured catalyst system to gain the maximum possible process benefits within the unique environment of a tubular steam reformer. Hence, the high voidage of CATACEL_{SM} SSR provides the operator with an intrinsically low pressure drop reaction media and the high geometric surface area delivers a high activity steam reforming catalyst.

Johnson Matthey's in-house PRIMARY software combines a variety of input data regarding the steam reformer in question with kinetic, pressure drop and heat transfer models to determine the potential benefits available through utilisation of CATACEL_{SM} SSR. Further optimisation then allows the product to be tailored to the requirements of the customer, with potential benefits versus standard pellets including:

- reduction in pressure drop, typically by up to 20%;
- reductions in steam:carbon ratio with no loss in carbon margins, typically by ~0.5 mol/mol. This can also reduce front end pressure drop due to the lower total process gas flow;
- savings in reformer trim fuel firing, typically of the order of 2-10%;
- possibility for increase in plant throughput, typically by 10-20%, with no change in tube wall temperature margin.

Secondary reformer

Upon leaving the primary reformer at temperatures usually in excess of 800°C, residual methane is still present in the process gas. In order to maximise conversion, a secondary reformer is commonly included in the flowsheet, whereby the reformer effluent is fed into a reaction vessel along with an oxidant. In an ammonia production facility the oxidant is air, providing a cost effective method of introducing nitrogen into the process gas. Combustion of a portion of the process gas provides enough heat for further reforming to occur over a catalyst bed reducing the residual methane to extremely low levels.

The successful design of the secondary reformer (from a process gas standpoint) depends upon three key components:

- the burner, which ensures an even distribution of the oxidant throughout the cross section of the vessel, which is important in ensuring an even flow through the catalyst bed;

- the combustion volume, where the mixing of the primary reformer effluent and oxidant, and subsequent combustion, occurs;
- the catalyst, which is essential in facilitating the reduction of residual methane to acceptable levels for downstream processing.

A conventional secondary reformer design is illustrated in Fig. 2, whereby the burner gun is located close to the point at which the vessel widens into its largest diameter. There are several potential issues with this style of reformer if not designed correctly.

- impingement of the flames onto the bed;
- control of the mixing within the combustion zone;
- catalyst disturbance.

Issues such as these are easily mitigated when considering Johnson Matthey's proprietary long neck design (Fig. 2) which achieves near-perfect mixing before the gas reaches the catalyst bed, removing the requirement for target tiles or hold down media and thus minimising pressure drop.

This concept has been applied in over 20 plants throughout a 40 year period with great success. The burner design has been proven to be highly reliable with maintenance free service lives well in excess of a decade.

The wider plant

Although there is a great deal of opportunity to improve plant performance by considering the reforming stage alone, it is also important to consider the wider plant when looking to reduce pressure drop and maximise plant efficiency. Johnson Matthey's experience with plant design and revamps has led to the development of a range of technologies to assist operations attempting to remove or reduce pressure drop.

Inlet distributors and outlet collectors

It is vital to obtain uniform distribution of process gas prior to catalyst bed entry to avoid issues associated with flow maldistribution, including increased pressure drop, reduced catalyst efficiency and localised overheating. Correct and efficient flow distribution can easily be obtained through the usage of well-designed inlet distributors.

Alongside inlet distributors, a correctly designed gas collector at the base of the

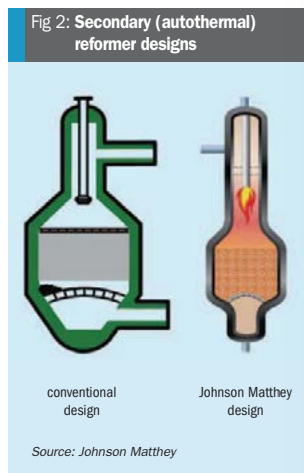

vessel will help reduce pressure drop within the vessel and increase process efficiency.

In both cases Johnson Matthey uses state of the art Computational Fluid Dynamics (CFD) techniques to analyse flow patterns within existing vessels and uses the information to provide bespoke designs specifically tailored to the needs of the customer. The designs may be offered separately, or as an integral part of a STREAMLINE™ retrofit.

STREAMLINE

Johnson Matthey has conducted a significant study into the pressure drop contributions of different parts of vessels such as the inlet nozzle, inlet distributor, hold down material, catalyst, support system, outlet collector and exit nozzle. Extensive modelling using CFD was used to confirm the pressure drops in specific areas of the vessel. The results demonstrated that the pressure drop contributions across the inlet distributor and outlet collector were minor, and that the contributions across the inlet nozzle and hold down media were negligible. It was shown that a significant portion of the vessel pressure drop was over the support material and the exit nozzle, demonstrating the need for an optimised support material.

STREAMLINE is designed to reduce pressure drop in fixed bed vessels (Fig. 3), and is suitable for use in many different converters. STREAMLINE uses a novel support material to significantly reduce the pressure drop in the annulus around the collector, where the

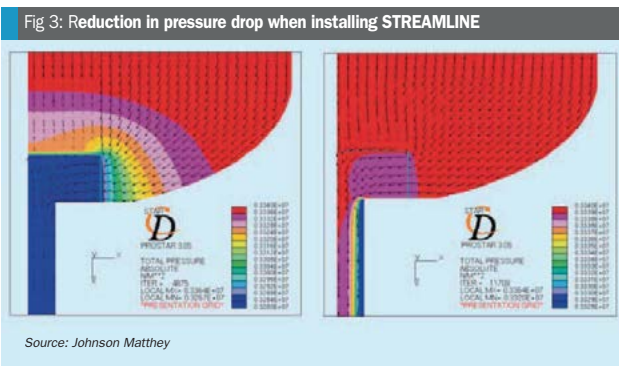

Table 1: Pressure drop savings after installation of new collectors and STREAMLINE

	Before installation	After installation	Actual saving	Predicted saving
HTS, bar	0.9	0.3	0.6	~0.6
LTS, bar	1.4	0.4	1.0	~0.8

Source: Johnson Matthey

bulk of the flow is radial and high velocities lead to high pressure drops. STREAMLINE low pressure drop support material meets all the critical criteria for the ideal support, including high voidage as a function of its shape, high strength, large particle size and low silica content.

The STREAMLINE service from Johnson Matthey comprises of:

- a complete study to identify accurately all of the sources of vessel pressure drop in a converter;
- a proven solution based on a proven support medium; and
- installation assistance.

More than twenty installations are operating in large plants worldwide, with typical single vessel pressure drop savings of around 0.4 bar.

Case study 1

Johnson Matthey completed a detailed study of the high temperature shift (HTS) vessels for an ammonia producer in North America. This showed that application of STREAMLINE would offer significant benefits in terms of reduced pressure drop and hence savings in compression costs. Plant performance after the installation of the STREAMLINE system confirmed that the pressure drop over the HTS section had dropped from an average of 1.3 to 0.5 bar,

a pressure drop reduction of around 60%. Based on a US natural gas price of \$2/GJ, this represents a \$120,000 per year saving in compression costs.

Case study 2

An ammonia plant built in 1969 had been updated from 600 t/d to around 770 t/d, and as a consequence pressure drop through the front end had increased. The process air compressor was now limiting the plant rate and as such, the rates could not be increased further. As part of a catalyst proposal, a revised vessel collector package was supplied by Johnson Matthey for the HTS and low temperature shift (LTS) reactors. This included:

- CFD modelling of new outlet collector;
- detailed mechanical design including full installation specification;
- manufacture and supply of the new outlet collectors;
- supply of STREAMLINE media and technical supervision of installation.

After installation, the new collectors in the HTS and LTS vessels saved 1.5 bar in pressure drop as detailed in Table 1.

This pressure drop reduction relieved the air compressor limit allowing the plant to make an additional 50 t/d of ammonia. The estimated additional profit from this was in excess of \$4.5 million per year.

Radial reactor technology

Traditionally, most catalyst beds, with the exception of the ammonia converter, have been designed to be axial. Whilst well proven and standard practice, this design methodology can lead to unnecessarily high pressure drops over the catalyst bed. In order to combat this, Johnson Matthey has developed radial reactor technology that enables traditional axial beds to be converted for radial operation. This technology has been successfully applied both in new plant designs and as a retrofit to existing vessels.

The modification, comprising of several scallops, a centre pipe and the associated support equipment, is easily installed into existing vessels. Due to the lower gas velocities and shorter gas flow-path this modification results in a typical pressure drop reduction of more than 80%.

Certain older generation plants may have shift reactors that are now found to be over-sized for the turnaround schedule and modern catalysts. Conventionally, these vessels are short loaded axially for a small pressure drop benefit. Alternatively, the extra space in the vessel can be used to install Johnson Matthey radial reactor technology to provide a significant pressure drop benefit to the operator.

From Fig. 4, it can be seen that the process gas is forced to the side of the vessel, where it is evenly distributed across a series of open ended, hollow scallops at the vessel wall. The process gas flows

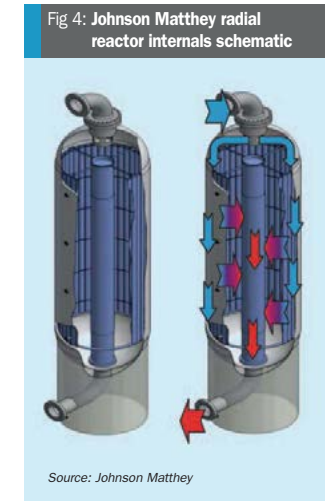

CONTENTS

What's in issue 341

COVER FEATURE 1

Long-term fertilizer demand

COVER FEATURE 2

Challenges for India

COVER FEATURE 3

Sulphur-enhanced urea

COVER FEATURE 4

Optimising catalytic reactors

NITROGEN+SYNGAS
ISSUE 341
MAY-JUNE 2016

BCInsight

Southbank House, Black Prince Road
London SE1 7SJ, England
Tel: +44 (0)20 7793 2567
Fax: +44 (0)20 7793 2577
Web: www.bcinsight.com
www.bcinsightsearch.com

Fig 5: Typical product composition and temperature profiles between cooling plates

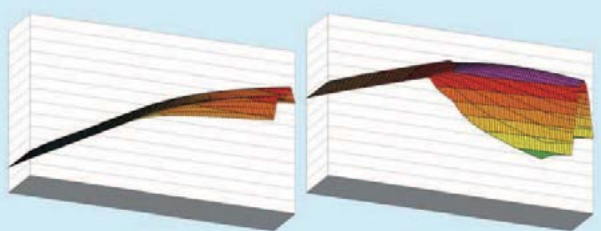

Source: Casale

radially from the scallops, through the catalyst bed to the central collector. For exothermic reactions the "out-to-in" flow pattern keeps hotter exit gases away from the vessel shell so allowing lower reactor shell design temperatures and further cost savings at the design stage.

Johnson Matthey's radial reactor technology has been successfully applied in a variety of applications, including ammonia synthesis, water gas shift (sweet and sour) and gas purification.

Casale simulation of pseudo-isothermal catalytic beds

Casale has widespread experience in the design of catalytic reactors. The main critical point in simulating catalytic beds with cooling is that the hypothesis of plug-flow (PF) on the process gas side is not valid. This means that the assumption that temperature, composition and other parameters are constant across a catalyst bed confined between cooling surfaces (intrinsic in one dimensional PF models) is incorrect.

On the contrary, there can be a great temperature difference between the catalyst layers near the cold cooling surface and the inner layers at the centreline between the cooling elements.

In Casale reactors the cooling elements are typically plates. Usually, but not always, the catalyst layers in contact with the plates are cooler (by tens of degrees centigrade) than the inner ones: this is due to both the thermal cooling effect of the plates and, in the case of exothermic reactions, due to the release of less heat of reaction, for kinetic reasons.

At the centreline the catalyst layers have a more adiabatic-like condition, so this inner layer kinetically starts faster

and quite rapidly reaches pseudo-equilibrium conditions, where the reactions are blocked for thermodynamic reasons (chemical equilibrium).

The typical product composition profile (Fig. 5) across a catalyst layer between two cooling plates is more or less a symmetrical, two maximum, bimodal profile with a low composition value at the wall cooling plates, a relative minimum at the centreline and two maximum composition values at an intermediate cross section coordinate between the centreline and surface of the walls.

This temperature and composition shape is more warped in relation to:

- increasing geometric distance between wall;
- decreasing conductivity of catalyst bed;
- increasing reaction heat transfer generation;
- decreasing convective gas thermal transport;
- increasing heat transfer coefficient at the wall and/or decreasing wall temperature.

In consideration of this evidence Casale has removed the hypothesis of plug-flow for reacting gas between cooling plates and introduced two more accurate simulation models that take into account the temperature (and composition) cross sectional profile:

- a fully 3D simulation software, Sector3D, developed on the basis of the finite volume method of Patankar and Spalding that computes the complete fields of velocity, pressure, temperature, compositions and related properties for the catalyst and cooling plates;
- a simplified 2Dplus simulation tool, Xenobi, that solves the partial differential equations of momentum, mass and energy balance in the two main directions of flow (radial and axial for

Fig 6: The sector 3D graphic interface

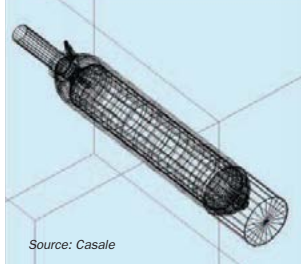

Source: Casale

cylindrical-shape like reactors), and solves analytically the temperature and composition profiles along the cross section between the cooling plates.

For each solution, it is of fundamental importance to use the most accurate models to predict fluid properties, kinetic reaction rates and heat transfer parameters. Casale's long experience in the field of ammonia and methanol converters provides an ideal basis for proprietary models for all of these quantities, which are constantly updated using field data.

Sector3D: fully 3D simulation of fixed bed catalytic reactors

In order to obtain accurate simulations of the fixed bed reactor performance, Casale has developed a fully 3D computer code to calculate velocity, pressure, temperature and composition fields in a fixed-bed reactor of any complex geometry.

The code considers two phases, catalyst and reacting fluid, with the same Eulerian approach.

A graphic interface allows the geometrical modelling of complex geometries (see Fig. 6) and provides the tools to impose boundary conditions on surfaces and material properties on volumes.

The code algorithm is a finite volume, segregated variable type, such as the one derived by Patankar and Spalding (SIMPLER method), and directly integrates the overall mass balance (continuity eq.), momentum (Navier-Stokes), energy (Fourier eq.), and single components mass balance (Fick) in each phase.

Appropriate equations have been adopted for thermodynamic and transport properties (rheological and turbulent) and for momentum, heat and mass transfer coefficients at boundary limits.

Accurate Casale proprietary chemical kinetics for ammonia and methanol synthesis have been developed and implemented for each chemical system of interest.

Cooling plates

Each cooling plate is simulated by means of multiple plug-flow fluid streams (cooling gas or boiling water) and exchanges heat with the catalyst layer. All physical quantities of interest can also be computed inside the plates.

Flowsheet reactor simulation

The Sector3D simulator is equipped with all the capabilities of a flowsheet simulator to build up any architecture of fixed beds, cooling plates series, mixers, splitters, heat exchangers as well as other equipment of interest. The result is a powerful and easy-to-use fluid dynamic simulator well-tailored to the needs of a chemical technology developing company. The Sector3D simulator can be easily adapted for any modifications, add-ins of new fluids and catalyst properties and new geometries.

Xenobi: All-in-one 2Dplus simulator for fixed bed catalytic reactors

The purpose of this all-in-one program is to provide chemical engineers with the relevant fields (velocity, pressure, temperature, composition) for fixed beds catalytic reactors.

The program solves all of the scenarios listed in Table 2.

The simulator considers a computational domain consisting of a volume bounded by

Table 2: All-in-one capacity of Xenobi

Geometries	Reactive system	Current contact	Coolants
annulus	ammonia	concurrent	reactive gas
circular sector	methanol	countercurrent	steam-water
circular segment	water gas shift	cross flow	diathermic oils
rectangle	formaldehyde	-	molten salts
trapezium	acrolein - acrylic acid	-	eutectic mixtures
others	others	-	others

Source: Casale

a right-angled cylindrical surface, based on generating closed curves of various shapes: annulus, circular sector, circular segment, rectangle, trapeze, etc. (see Fig. 7).

The domain is described case by case by a suitable cylindrical or orthogonal coordinate system.

The integration of local balance equations of mass, energy and momentum, is carried out by standard methods: numerical finite volume integration along the x and z axis and analytical solutions in a series of orthogonal eigenfunctions in the y direction.

In this sense the solution is claimed to be 2Dplus, because it also gives periodic solutions along the y axis. These periodic fields are necessary to evaluate, for example, the maximum temperature between two plates, important information for estimating catalyst life.

The program is provided with a flowsheeting tool. Each current array can be connected to all others via a splitter (splitting factors assigned) and an input mixer.

The kinetic model has the functional form of the classical Temkin equation. An effectiveness factor η takes into account the diffusion phenomena of catalyst particles. The effectiveness factor is a complex function of pressure, temperature, composition and particle equivalent radius R_{pe} .

A high level of accuracy is obtained by using proprietary correlations for heat and mass transfer coefficients especially for those involved at a gas-solid interface and in calculation of the equivalent thermal conductivity of a catalyst bed.

Ammonia synthesis loop analysis

Casale is not only experienced in the detailed simulation of catalytic reactors but also in the analysis of larger systems like the entire synthesis loop or even the whole ammonia plant. The following sections provide an example of the analysis of a synthesis loop which was upgraded by installing Casale internals for the synthesis converter and Clariant AmoMax[®]-10 catalyst. The study was

Fig 7: Possible simulation domains

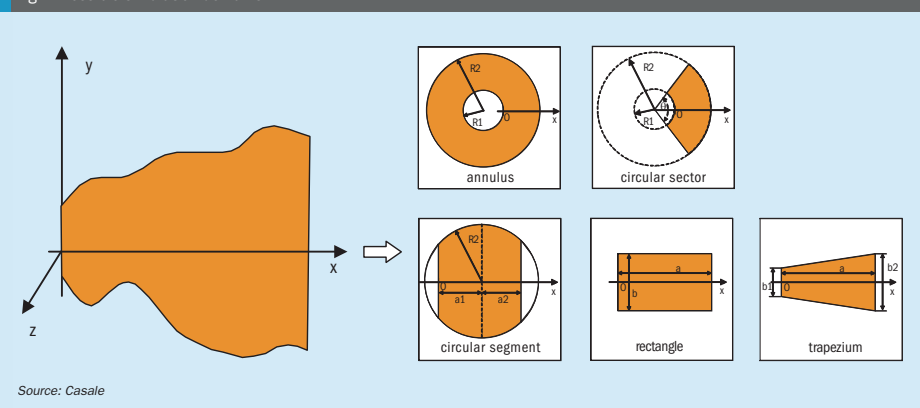

Source: Casale

based on both a traditional energy balance and an exergy balance, which gives greater insight into system inefficiencies.

Traditionally, chemical processes have been improved by the systematic use of energy and mass balances. In the last decades, however, process improvements have become more difficult and energy savings marginal. In order to achieve higher goals, new structured process analysis methods are needed.

Exergy is a thermodynamic property that links the concept of enthalpy and entropy. The exergy of a system is the maximum useful work possible that brings the system into equilibrium with the surrounding. Exergy measures the quality of an energy stream.

The exergy analysis explains the causes of energy losses in the ammonia synthesis loop and allows a better understanding how to increase the overall efficiency. Exergy analysis has been used to demonstrate that energy savings generated by the combined use of Clariant's AmoMax[®]-10 catalyst and Casale's 3-bed axial-radial converter result in lower opex.

Recently, Casale carried out the revamp of a 1,050 t/d ammonia synthesis loop. The specific energy consumption of the ammonia synthesis loop before the revamp was approximately 3.38 GJ/tonne at end of run (EOR).

The customer wanted to maximise energy savings while keeping capital investment low. The solution was to replace the existing 2-bed pure-axial reactor loaded with standard magnetite type catalyst with a new Casale 3-bed axial-radial ammonia converter loaded with Clariant AmoMax[®]-10

Table 3: Main process data of the synthesis loop

	Base case (SOR)	Revamped case (SOR)
Nominal loop capacity, t/d	1,050	1,050
Loop pressure at circulator discharge, bar(g)	190.8	174.4
Circulation flow, Nm ³ /h	470,200	436,300
Inert concentration (CH ₄ +Ar), % mol/mol	8.94	9.47
Converter inlet temperature, °C	223.9	210
Converter outlet temperature, °C	430.0	430.8
Delta ammonia concentration across the converter, % mol/mol	14.86	16.01
Steam production, t/h	43.85	44.07
Specific energy consumption, GJ/t	2.98	2.54

Source: Clariant

catalyst. Table 3 summarises the main process parameters of the ammonia synthesis loop before (base case, old equipment + standard catalyst at start of run) and after the revamp (revamped case, AmoMax[®]-10 + Casale converter).

Figure 8 shows a simplified process flow diagram of the ammonia synthesis loop under analysis. The make-up syngas produced by a steam reformer based front end is compressed to the desired synthesis loop pressure and then mixed with the loop recycle gas.

The syngas mixture is heated up to the optimal converter inlet temperature in the feed/effluent heat exchanger. This is done by recovering the heat of the hot gas exiting the steam generator of the ammonia loop.

After passing again in the above-mentioned feed/effluent heat exchanger, the

ammonia-rich syngas has to be cooled down in order to separate ammonia by condensation. Condensation is realised stepwise cooling down the syngas up to 5°C using an air cooler and ammonia chiller. Ammonia is then sent to the refrigeration section, while the non-condensable gases are partially purged to maintain the inerts level in the syngas at a desired level. The separated syngas, still rich in hydrogen and nitrogen, is recirculated and is sent back to the syngas compressor.

Casale 3-bed axial-radial ammonia converter

Casale has widespread experience in the design of ammonia converters. More than 200 converters have been built or

revamped with Casale 3-bed axial-radial technology.

The combination of the axial-radial gas path into the catalytic bed and the selection of a 3-bed configuration allows the performance of the synthesis loop to be enhanced. Since a higher per-pass conversion is achieved, the circulation gas flow in the loops is reduced. Consequently, the total pressure drop becomes lower.

Furthermore, the Casale reactor design guarantees mechanical strength, reliability and easier mechanical construction and installation.

The Casale converter technology can be applied to all existing ammonia synthesis loops by installing a completely new reactor or revamping the internals of the existing one.

The path of the syngas flow in a Casale axial-radial 3-bed-2-interchanger converter such as the one installed for this revamp is outlined in Fig. 9. The syngas is further pre-heated by the effluent of the second and then the first bed in the internal heat exchangers before entering the first catalytic bed.

Independent control of each of the three bed temperatures is essential in order to obtain an optimum operation of the converter in every condition (i.e. start-of-run vs end-of-run catalyst performance, plant load change) for maximum energy saving and thus highest return on the converter retrofit investment.

The temperature control for first, second and third bed is provided respectively by the cold shot, the bypass of the interchanger between the second and third bed, and the bypass of external feed effluent heat exchanger.

The axial-radial flow pattern in the catalyst results in an empty cylindrical core around the converter centreline. This is the ideal location for the interbed heat exchanger. The third bed outlet stream is at high temperature. It is not used to



Clariant AmoMax[®]-10 Catalyst for ammonia synthesis.

pre-heat the feed gas, but is sent to a downstream boiler and boiler feed water preheater in order to maximise the production of high pressure steam.

Clariant AmoMax[®]-10 catalyst for ammonia synthesis

As the design and operation of ammonia plants have become more demanding, reliable, high performance catalysts have become increasingly important. Clariant's ammonia synthesis catalyst, AmoMax[®]-10, with its higher catalytic activity at lower temperature and pressure, plays a major role for smaller and less costly reactor designs and improved efficiency in ammonia production.

AmoMax[®]-10, is based on non-stoichiometric ferrous oxide, wustite (Fe_(1-x)O, with x = 0.03-0.15) resulting in a significantly lower oxygen-content than standard magnetite catalysts.

Due to the deficit in oxygen in the crystal structure, AmoMax[®]-10 is easier and faster to activate than magnetite; typically, allowing users to shorten the reduction time by at least one day, depending on specific plant conditions.

The first commercial application of AmoMax[®]-10 was installed at Liaohu Huachin Chemical Group in Panjin, China in

Fig 8: Simplified process flow diagram of the ammonia synthesis loop

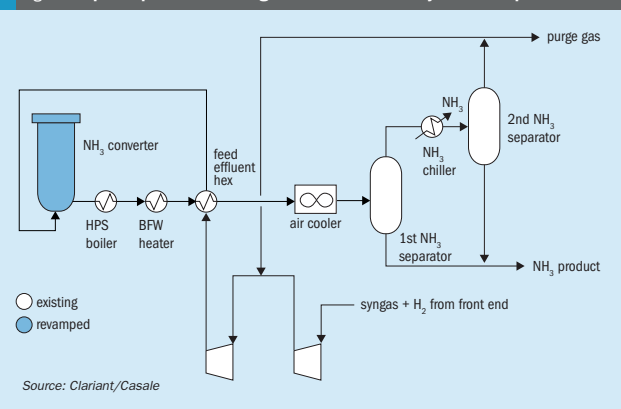

Fig 9: Casale 3-bed-2-ICH converter gas path

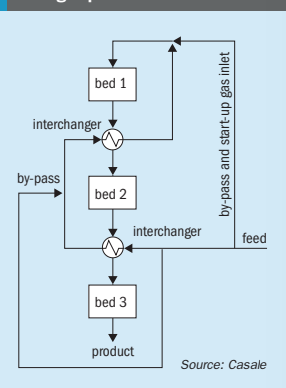

Fig 10: Results of the energy balance case: diagram of inputs, products and losses

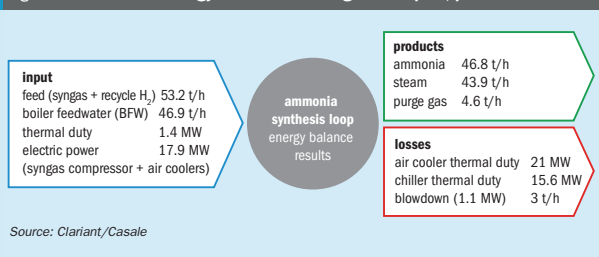

Fig 11: Results of the energy balance for the base case: distribution of energy losses

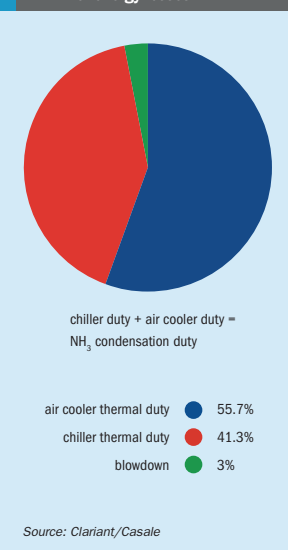
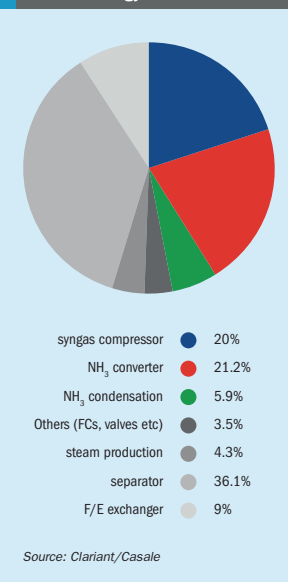

Fig 12: Results of the exergy balance for the base case: distribution of exergy losses



What's in issue 341

COVER FEATURE 1

Long-term fertilizer demand

COVER FEATURE 2

Challenges for India

COVER FEATURE 3

Sulphur-enhanced urea

COVER FEATURE 4

Optimising catalytic reactors

Fig 13: Exergy analysis for the base case vs revamped case: dissipation of exergy

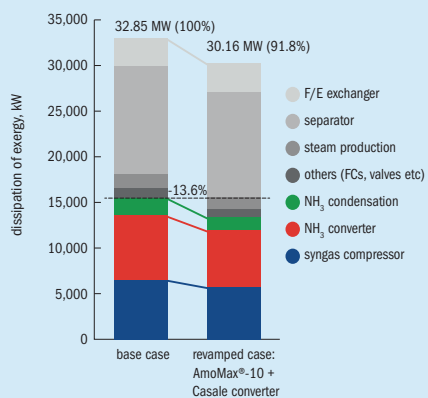

Source: Clariant/Casale

Fig 14: NH₃ synthesis loop specific energy consumption savings

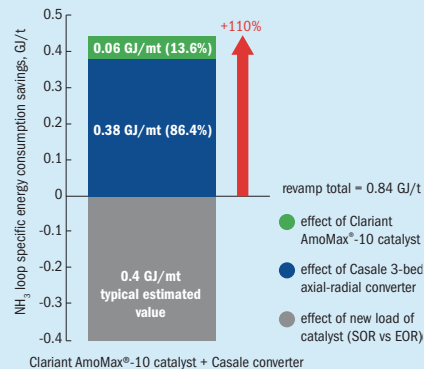

Source: Clariant/Casale

December 2003. Casale revamped this unit (first start-up in 1976) in 1988 by installing a Casale 3-bed axial-radial converter. Since then, Clariant and Casale have achieved a proven track record of success through a number of global references.

Results of the energy analysis

The results delivered by the traditional energy analysis method applied to the ammonia synthesis loop before the revamp (Table 2, base case) are summarised in the diagram of Fig. 10.

Simulations were performed with a commercial process calculator (Unisim Design Suite) and Casale proprietary thermodynamic equation of state.

The inputs in the ammonia synthesis loop are the syngas feed, boiler feed water for steam production, thermal duty for feed preheating purposes and electric power for the syngas compressor and air coolers. The refrigeration cycle is outside of the system boundary; in this way, the energy needed for generation of the cold duty is not taken into consideration as an input of the ammonia synthesis loop.

The outputs of the ammonia loop can be divided into two categories: the products and the losses.

Products are ammonia and other by-products of the process, namely, high pressure steam and purge gas, which can be used as secondary fuel in other plant units.

Losses are the mass and energy streams flowing outside the boundary of the system that have no favourable utilisation. For example, the thermal duties for ammonia condensation discharged to the environment through the air cooler or to the refrigeration cycle through the chiller are considered as energy losses.

The distribution of ammonia synthesis loop energy losses is shown in Fig. 11. The diagram shows that the majority of the losses (approx. 97%) are generated for ammonia condensation. This step takes place at near atmospheric temperature (air coolers, 55.7%) and at temperature below the ambient temperatures (chillers, 41.3%).

The indication provided by the energy analysis, to increase the efficiency of the ammonia synthesis loop, is essentially to concentrate efforts on increasing the efficiency of chillers and air coolers. This is only partially possible and is linked with the installation of higher heat exchange surface areas, which is per se a strongly capex intensive measure. However, the effects of the intervention on these pieces of equipment will only have a very limited impact on the energy savings of the ammonia synthesis loop as demonstrated by the exergy analysis.

As shown in Fig. 11, the energy analysis method does not provide any valuable insight regarding the exploitation of

Table 4: NPV based analysis parameters and scenarios definition

Parameters	Scenario A	Scenario B
Cost of capital in Western Europe, %	10	10
Cost of NG in Western Europe* (approx.), \$/million Btu	6.5	10
Currency, \$/€	1.09	1.2
Ammonia price Western Europe** (approx.), \$/t	350	500
Time on stream, years	15	15
Catalyst faster reduction time by, days	1.5	1.5
Catalyst lower light-off temperature (faster restart by), days	0.3	0.3
Reactor restarts, number per year	1	1

* https://ycharts.com/indicators/europe_natural_gas_price, Scenario A Q4/2015, Scenario B Q2/2014
 ** Fertecon, Ammonia Futures, Nov. 2015, Scenario A Q4/2015, Scenario B Q2/2014

Source: Clariant

17 2013



Big changes SOMETIMES START SMALL.

CATALYST SOLUTIONS THAT DELIVER VALUE: CLARIANT CATALYSTS.

Our products are small, but they deliver big value. Use our high-performance catalysts to make more of what you want and less of what you don't, all with less energy. We are ready for your big challenges.

WWW.CATALYSTS.CLARIANT.COM

CLARIANT

centimeter 11



Trust our long experience from predecessor company Süd-Chemie.

what is precious to you?

CONTENTS

What's in issue 341

COVER FEATURE 1

Long-term fertilizer demand

COVER FEATURE 2

Challenges for India

COVER FEATURE 3

Sulphur-enhanced urea

COVER FEATURE 4

Optimising catalytic reactors

NITROGEN+SYNGAS
ISSUE 341
 MAY-JUNE 2016

BCInsight

Southbank House, Black Prince Road
 London SE1 7SJ, England

Tel: +44 (0)20 7793 2567

Fax: +44 (0)20 7793 2577

Web: www.bcinsight.com
 www.bcinsightsearch.com

Fig 15: Value creation (NPV basis compared to standard)

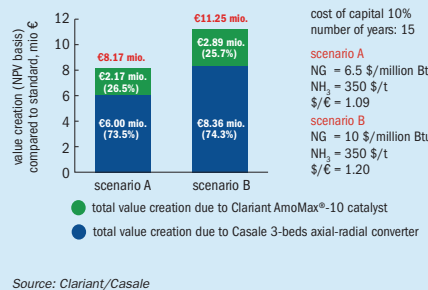

Table 5: Value creation of Clariant AmoMax[®]-10 compared to standard catalyst

Opex savings

Value creation (NPV Basis)	Scenario A	Scenario B
Lower energy consumption, € million (lower loop pressure/lower recycle rate)	0.948	1.319
Quicker reduction (less syngas needed + more NH ₃ production)	0.483	0.622
Faster restart, € million (lower light-off temperature)	0.735	0.946
Total value creation, € million	2.166	2.887

Source: Clariant/Casale

energy in the different components of the system. In fact, energy is a conserved system parameter and the balance across a component would be zero.

The specific energy consumption of the ammonia synthesis loop has been evaluated considering the energy consumption of the syngas compressor and air cooler drivers and the energy recovery linked to the production of high pressure steam.

The value of the ammonia synthesis loop specific energy consumption for the revamped case with AmoMax[®]-10 has been calculated to be 2.54 GJ/t while for the base case the value is 2.98 GJ/t. If we consider the effect of a new load of standard catalyst (SOR vs EOR) to be equal approximately to 0.4 GJ/t, the revamp total energy consumption savings add up to 0.84 GJ/t.

The results delivered by the exergy analysis applied to the base case in Table 2 are summarised in Fig. 12. Exergy is not a conserved quantity and is dissipated in successive irreversible events occurring in the equipment. Therefore, in addition to the absolute value of the energy dissipated globally by the process, it is possible to understand where the losses are generated and it is possible to intervene precisely in order to minimise them. In this way, it is also possible to accurately allocate valuable resources in order to get the best of the capital investment.

On the contrary to the indication of the energy analysis, ammonia condensation (green) only accounts for approx. 5.9% of the total exergy dissipation in the ammonia synthesis loop; energy analysis presented them as almost the only source of losses in the system.

The losses generated by the syngas compressor and the ammonia con-

verter are 20% and 21.2% respectively. These three sections together represent slightly more than 47% of the total exergy dissipation.

It is interesting to see that the highest exergy dissipation is generated in the separators. A separator is a passive item of equipment and very few actions can be addressed to reduce its impact on the global count of irreversibilities. The exergy balance across a separator can easily explain the generation of the irreversibilities. Pressure and temperature changes across a separator are negligible; therefore, dissipation due to enthalpy variations is very low. Entropy changes are considerable however; the separated gas and liquid phase have a much lower entropic level if compared to the two-phase mixture upstream the equipment. One can say that a separator is bringing "order" into the system and for this reason exergy losses are intrinsic of the separation process.

Steam production only accounts for 4.3% of the total losses, which means that no actions needs to be taken to increase efficiency of the steam system.

Results of the exergetic performance of the ammonia loop before and after the revamp (base case vs revamped case) are presented in Fig. 13.

The exergy dissipated by the system lowers considerably after the revamp from 32.85 MW to 30.16 MW. This corresponds to a reduction of irreversibilities by approximately 9.2%.

From Fig. 13 it is possible to appreciate that the reduction of the irreversibilities is concentrated exactly where promised: the syngas compressor (blue), the ammonia converter (red) and the ammonia condensation (green) section. Considering only

these three components, the losses are reduced even more, by 13.6%.

The following is on the basis of the reduction of irreversibilities: AmoMax[®]-10 presents higher catalytic activity at lower loop pressure providing the possibility of reducing recycle ratio. Furthermore, the Casale 3-bed axial-radial ammonia converter allows for better utilisation of the catalyst volume and a reduction of pressure drop, achieves higher process performances and higher conversion per pass if compared to traditional designs using the same volume of catalyst.

NPV based analysis of the investment

The global energy savings due to the joint use of Clariant's AmoMax[®]-10 catalyst and Casale's 3-bed axial-radial ammonia converter have been presented. In Fig. 14, the contributions of the catalyst and reactor to the energy savings are itemised for a deeper understanding.

The effect of simply refilling a new load of catalyst in the existing converter typically delivers energy savings as high as 0.4 GJ/t (grey bar). The additional energy saving obtained with the revamp installing the 3-bed axial-radial converter (blue bar) and AmoMax[®]-10 catalyst (green bar) is 0.44 GJ/t. This represents an increase in energy savings by +110% compared to the simple refill case. These are distributed as follows: 0.06 GJ/t (13.6%) generated by the AmoMax[®]-10 catalyst and 0.38 GJ/t (86.4%) generated by the 3-bed axial-radial ammonia converter.

The energy saving is directly related to the reduction of opex. The value creation due to reduction of opex is calculated by means of a NPV (net present value) based analysis.

Other parameters used for the analysis are summarised in Table 4.

Fig 16: Different types of catalyst support and gas collection systems

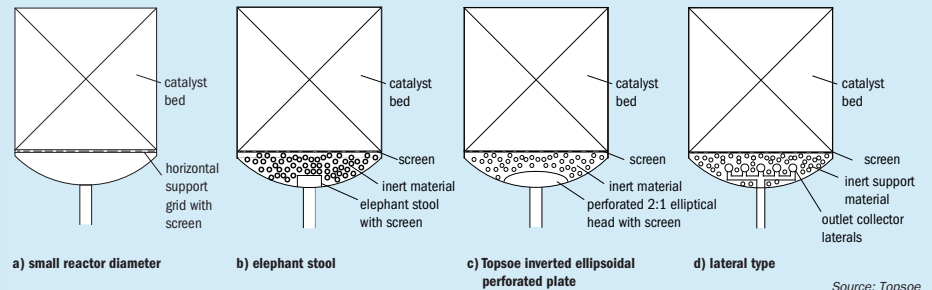

Scenario A represents a price level representative of the actual situation while Scenario B represents a desirable future scenario at a price level for natural gas and ammonia prices that has been experienced in recent times.

The results of the NPV based analysis for the two scenarios are presented in Fig. 15. For Scenario A (lower NG and ammonia prices refer to Q4/2015), the total value created by installing AmoMax[®]-10 catalyst and the 3-bed axial-radial ammonia converter have been evaluated to be approx. €8.17 million.

For Scenario B (higher NG and ammonia prices refer to Q2/2014), the total value created has been evaluated to be approx. €11.25 million.

The opex savings on a NPV basis generated by the Casale converter are due to energy savings over 15 years, while those generated by Clariant catalyst can be attributed to several factors (see Table 5).

The opex savings generated by AmoMax[®]-10 are essentially due to the lower energy consumption (over 15 years), quicker reduction (once at year 0) and faster restarts (typically once per year for 15 years). A quicker reduction not only means less electric power consumption for the start-up heater (not considered in this analysis), but also less syngas consumed for reduction; in addition, the plant can be brought on stream more easily and starts ammonia production earlier. This last aspect is also valid for faster restarts. The considerably lower light-up temperature of AmoMax[®]-10 allows faster restarts/start-up of the loop (saving energy and time) and results in less potential for loss of reaction during an upset, which adds a safety margin to ammonia plant operation.

Topsoe support grids for shift reactors

In the past, reductions in the pressure drop of the shift section have primarily been achieved by short loading catalyst volumes and, in extreme situations, paralleling of shift reactors. The pressure drop in the shift section associated with inert support material and outlet collector systems has largely been ignored.

The types of catalyst support and collection systems are primarily dependent upon the reactor diameter. For smaller reactors with internal diameters of less than approximately 2 m the catalyst is generally supported on a flat, horizontal grid across the entire diameter of the reactor. The grid is normally covered with a screen to insure that catalyst does not escape into the exit pipe (Fig. 16a).

In larger diameter reactors, a flat horizontal support grid is generally not used due to the increasing size and the associated cost of the grid. Three types of gas collection systems commonly used in large reactors are:

- elephant stool;
- inverted perforated ellipsoidal head;
- lateral-type gathering system.

In all of these gas collection systems, the catalyst is primarily supported by an inert media that rests on the bottom head of the reactor.

A typical elephant stool collection and support system is shown in Fig. 16b. The elephant stool carries the load of the inert support and catalyst directly above the outlet pipe. Typically there is a solid plate on the top of the stool, which is supported by flat bars ("legs") equally spaced around its circumference and resting on the bottom head. A screen covers the cylindrical part of the elephant stool, insuring that the inert

support material will not escape into the outlet pipe. The elephant stool design has a proven reliability in the industry. However, the dynamic gas collection characteristics associated with the elephant stool and inert support media can lead to flow maldistributions and additional pressure drop.

The inverted perforated ellipsoidal head collection and support system is shown in Fig. 16c. The inverted ellipsoidal head is inherently strong and supports the inert support media and catalyst above the outlet pipe. In addition to strength, the ellipsoidal shape provides a relatively large cross-sectional area for the collection of the reactor effluent gas. The perforations in the plate are generally covered with screen to prevent any material from escaping into the exit pipe. The perforations are designed to provide minimum flow restriction. This collection system has been the standard in Topsoe designed reactors for many years. The design is industrially proven and provides structural reliability and good flow characteristics with minimal capital costs.

A typical lateral-type outlet collection system is shown in Fig. 16d. In this design, the primary purpose of the laterals is to evenly collect the flow from the catalyst bed and provide a relatively smooth transition into the outlet pipe. The laterals are covered with screen, which prevents the inert support and catalyst from escaping into the outlet pipe. The weight of the catalyst is primarily supported by the inert support media, which rests on the bottom head of the reactor.

This design is industrially proven to be structurally reliable and provide good flow characteristics. The drawback is the significant capital costs and complexity associated with the installation.

Fig 17: Support grid design before and after replacement

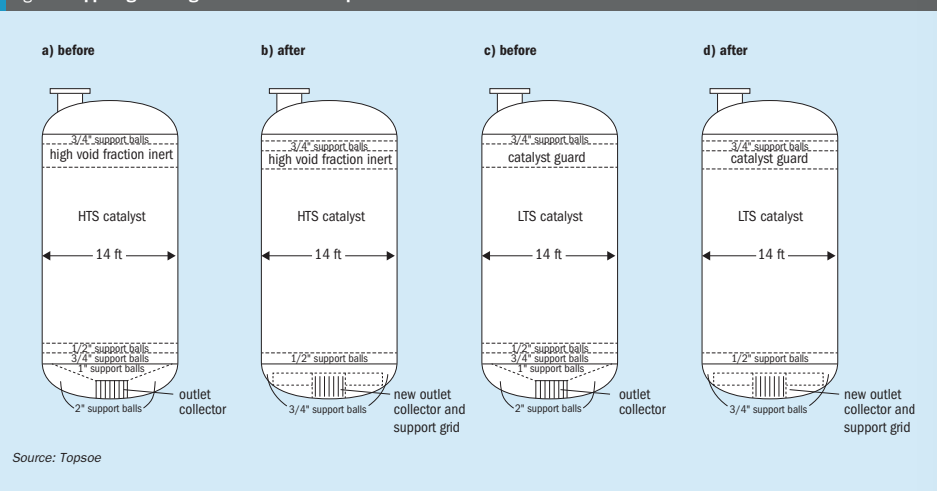

Source: Topsoe

In order to make sure that the Topsoe-designed inverted ellipsoidal head collection system was providing the desirable flow characteristics in shift reactors, Topsoe used computational fluid dynamics to model the flow. The results of the modelling showed that no significant flow maldistribution patterns were present in the catalyst bed or in the support material. In addition, the pressure loss across the collection system was minimal.

The following case history provides a recent example of modifications that have been made to the catalyst support system in the shift section of an ammonia plant to decrease pressure drop and reduce the operating cost.

Replacement support grids at Agrium

Agrium's Fort Saskatchewan Nitrogen Operation (FNO) operates a M.W. Kellogg designed ammonia plant with a nameplate capacity of 1,000 t/d. The production of the ammonia plant had been increased to 1,300 t/d due to several small debottlenecks and by maximising existing equipment capacity. To achieve further incremental increases in ammonia production and for better energy efficiency FNO teamed up with Haldor Topsoe engineers to design and supervise the safe installation of the catalyst support grids in the HTS and LTS reactors.

In June 2014, FNO took an outage to perform maintenance on the ammonia plant. This maintenance included the replacement of the high and low temperature shift catalysts. Upon removal of the spent catalysts and support balls, new catalyst support grids supplied by Topsoe were safely installed inside the reactors. The reactors were then reloaded with Topsoe's HTS and LTS catalysts. The plant was restarted, the catalysts were reduced and HTS and LTS put online.

Original configuration and performance

The HTS reactor at FNO had an original internal configuration as shown in Fig. 17a. This configuration had been utilised in the HTS reactor since plant inception and only changes to catalyst and support balls have been made in order to reduce pressure drop. The typical volume of catalyst loaded in FNO's HTS reactor is approximately 42.47 m³ and is changed-out every four to five years in order to correspond with maintenance outages. The original configuration in the HTS provided a relatively low pressure drop of approximately 23 kPa at start of run, increasing to approximately 77 kPa after 60 months.

The original internal configuration of the LTS reactor is shown in Fig. 17c. This configuration had also been utilised since plant inception and changes to catalyst and support balls had also been made in order to reduce pressure drop. The LTS

is typically loaded with 50.97 m³ of catalyst but is capable of holding up to 62.30 m³. The "short" load of LTS catalyst better aligns with FNO's maintenance outages and not only reduces pressure drop across the catalyst bed but also reduces the amount of active catalyst wasted. This particular charge of LTS catalyst had a pressure drop of 40 kPa at start of run, increasing to 62 kPa after 50 months.

New support grid design

The Topsoe catalyst support grid consists of a modified outlet collector, outlet brackets, outlet connector rods, skirt section and a mesh grid section, all of which floats in the bottom of the vessel of interest. A side and top view of the grid is shown in Fig. 18 and Fig. 19 respectively.

Prior to purchase and installation FNO identified several advantages of the Topsoe catalyst support grid design which aided in the decision to complete the investment project.

Short fabrication time: Topsoe was able to fabricate both grids in a 16 week window (standard supply time) and claims that as little as 6 week fabrication is possible if required.

Flexible mechanical sealing: No packing rope or insulation is needed to seal the catalyst support grid to the vessel wall. A good seal between the support grid and

Fig 18: Side view of support grid in vessel

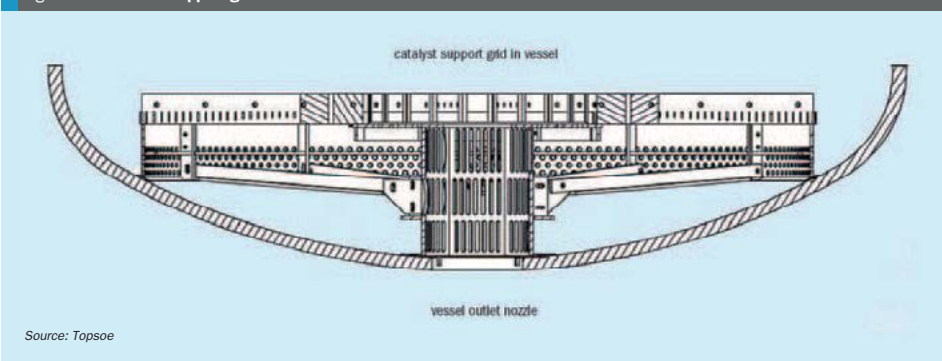

the vessel walls which performs well over thermal cycles is critical in preventing support ball or catalyst migration over the life of the grid through many shutdowns.

Top manway hatch: One change from previous Topsoe catalyst support grid designs is the addition of an inspection hatch located at the top of the outlet collector to allow access to the outlet collector and outlet piping for inspection during maintenance outages without having to disassemble and remove the entire catalyst support grid.

No weld installation: A no weld installation does not require approval from local pressure vessel authorities for modifying equipment, reduces the installation time required and enabled the installation to be completed by FNO's catalyst removal and loading contractor, who is well trained and equipped for confined space entry and has experience with numerous catalyst containing vessels.

Predicted pressure drop reduction: Prior to installation of the catalyst support grids in the HTS and LTS reactors, Topsoe presented the CFD modelling on their support grid design to Agrium FNO. Two excerpts from a recent CFD model report for the catalyst support grid compares the original elephant stool outlet design with the new support grid (Figs 20 and 21). As observed in the CFD model, a large part of the new support grid pressure differential is caused by the exit losses through the outlet pipe and the difference in volume and placement of the support balls. The total pressure loss of the new reactor bottom outlet design was estimated to be about 60%

Fig 19: Top view of support grid

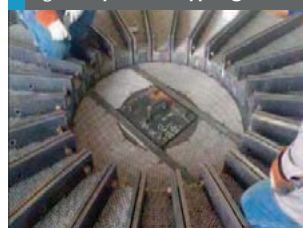

PHOTO: TOPSOE

lower than with the elephant stool type design.

New configuration and performance

HTS reactor
The new grid was installed in the HTS reactor without any impact to schedule or employee wellbeing. After installation it was topped with a small layer of 19 mm support balls and a layer of 13 mm support balls. This was followed by

Fig 20: CFD model of original elephant stool

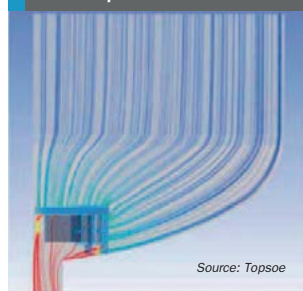

Source: Topsoe

Fig 21: CFD model of catalyst support grid

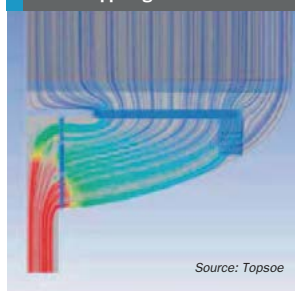

Source: Topsoe

Haldor Topsoe's SK-201-2 HTS catalyst and topped with a layer of TK-20 (high void fraction inert material) and 19 mm support balls. The new configuration is shown in Fig. 17b.

After a successful start-up of the ammonia plant the ΔP performance of the HTS decreased by approximately 36% or 8 kPa at the start of run.

LTS reactor

The LTS reactor was also installed without injury and met schedule requirements. On top of the newly installed grid a layer of 19 mm support balls and a layer of 13 mm support balls were loaded. On top of this was Haldor Topsoe LK-821-2 and LSK catalyst. Finally, the catalyst volume was topped with 19 mm support balls (see Fig. 17d).

After start-up the LTS experienced a relatively significant decrease in pressure drop – an approximate decrease of 50% – 23 kPa less than previously seen at FNO (see Fig. 22).

CONTENTS

What's in issue 341

COVER FEATURE 1

Long-term fertilizer demand

COVER FEATURE 2

Challenges for India

COVER FEATURE 3

Sulphur-enhanced urea

COVER FEATURE 4

Optimising catalytic reactors

NITROGEN+SYNGAS
ISSUE 341
MAY-JUNE 2016

BCInsight

Southbank House, Black Prince Road
London SE1 7SJ, England
Tel: +44 (0)20 7793 2567
Fax: +44 (0)20 7793 2577
Web: www.bcinsight.com
www.bcinsightsearch.com

Economic benefits realised

The amount of support material required for the new grid configuration is less than what was required for the original configuration. FNO determined that the savings from the reduction in material for the bottom section of the HTS and LTS reactors was approximately \$32,200 and \$8,620 respectively.

In addition to the material cost savings a reduction of support material also reduces the amount of time necessary to unload and load the HTS and LTS reactors. Impacting the unloading and loading times the most are the large 50 mm support balls, due to their weight and the power required to vacuum them out of the vessel. The HTS and LTS unloading and loading labour savings were approximately \$27,300 and \$29,400 respectively.

Finally the production increase due to the reduction in pressure drop in the ammonia plant was calculated to equate to approximately 3.28 t/d.

Considering all the savings described above the payback for both catalyst support grids was approximately 7.3 months.

The Haldor Topsoe Exchange Reformer (HTER)

Topsoe has extensive experience in designing heat exchange reformers that utilise the heat from tubular reformers, ATRs or secondary reformers for additional reforming. Heat exchange reforming was first developed in the late 1980s and further improved during the 1990s. The first commercial installation using the HTER was put into operation in 2003 in a CTL unit in South Africa. Since then, the same customer has installed four more HTER reactors. In 2008, a hydrogen unit was revamped for larger capacity by introducing an HTER, and in 2012, the first grassroots hydrogen HTER unit was commissioned. Topsoe is currently designing HTERs for both grassroots and existing ammonia producers. One of the main benefits of having an HTER in grassroots ammonia plants is that it gives the opportunity to use alternative fuels for steam production such as coal or petcoke, which may be cheaper and more readily available. Examples have shown that shifting steam generation from process-gas-fired waste heat boilers to coal-fired auxiliary boilers is an attractive solution. By optimising the steam production for the

entire production complex, the cheapest and most secure solution may be one that does not rely solely on generating high pressure steam within the ammonia unit from natural gas fuel.

For stand-alone ammonia producers, a steam-neutral ammonia unit offers lower fuel consumption and reduced emissions compared to a traditional layout.

As an ammonia revamp option, the HTER may provide up to 25% additional reforming capacity and is a flexible option that can be accommodated within most plot plans. The HTER is an add-on to the existing reforming section and can be installed with only minor modifications to the existing equipment. Installing an HTER is also a way to shift the fuel consumption for steam generation.

The HTER concept

Figure 23 shows the placement of an HTER in an ammonia front-end. The sensible heat of the hot process gas from the secondary reformer is utilised for reforming a part of the feed, bypassing the main reforming section. In this way, up to 50% of the duty normally used for HP steam production in the waste heat boiler can be redirected for more efficient use in the reforming process.

Grassroots plants

In ammonia plants, the energy from the hot effluent from the secondary reformer is typically utilised for high pressure steam generation. The steam is used for driving the turbines within the unit, and the excess steam is exported for instance to the CO₂ compressor turbine in case of urea production. The steam is an important part of the energy balance and is easily as valuable as feed, fuel and other utilities. It may, however, be an expensive way of producing steam when compared to alternatives such as auxiliary boilers, which use less expensive fuels, e.g. coal or petcoke. Topsoe proposes that the inclusion of an HTER in grassroots ammonia plants will make it possible to optimise the steam balance and the utilisation of the most cost beneficial fuels for the entire complex. Other benefits of the HTER include size reduction of the reforming section.

In 2014, Topsoe designed an ammonia unit for a European fertilizer producer where the steam balance was optimised for the entire complex. The result of this optimisation was a strict limitation on the maximum allowable HP steam export for

Fig 22: Pressure drop of LTS reactor (new grid configuration: 10 month service life)

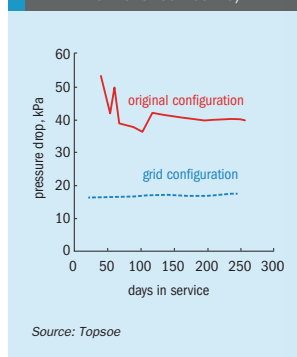

the ammonia unit. The solution for meeting the maximum steam export requirements was to include an HTER, and the final outcome was an optimisation of the available fuel resources for the fertilizer complex. The plant is currently under construction and expected to start up in 2017.

Table 6 compares the HTER layout to a traditional layout.

As seen from the table, the specific energy reduction with the HTER included is significant for the ammonia unit, with regard to both fuel consumption and steam export reduction. It is this balance that was included in the optimal total steam balance for the fertilizer complex and was ultimately the most cost-efficient option. Any steam requirement outside the ammonia unit is supplied by other means, primarily auxiliary boilers. Also, in this way the steam production is easily regulated to match the actual requirements. Similarly, a Swedish customer has asked for studies on an HTER option due to their need to run their auxiliary boiler at minimum load in order to ensure sufficient steam backup at all times. The problem the customer was experiencing was an overproduction of steam and waste of fuel. In this case, an HTER would reduce the steam output from the production unit enough to minimise fuel consumption.

The HTER solution opens up the possibility of using cheaper or more available fuels for steam production. From a cost point of view this may give immediate results, but in a changing world where the availability and taxation of different fuel types are constantly in motion, the ability

Fig 23: Bayonet HTER in NH₃ plant front-end

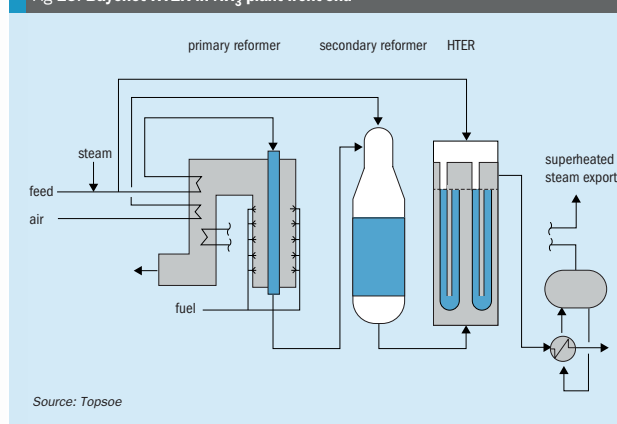

Table 6: Production and consumption figures for two ammonia plant layouts

	Traditional layout	With HTER
NH ₃ production, t/d	1,600	1,600
Fuel consumption, Nm ³ /h	15,104	10,441
Steam export, t/h	60	0
Fuel reduction, Gcal/t	-	0.61
Fuel savings, €/t	-	11.8*

*Fuel savings assuming a NG price of \$8/MMBtu and a coal price of \$2.4/MMBtu.
Source: Topsoe

to use a variety of fuels and feedstock will give a competitive advantage as well as a higher chance of maintaining full production capacity.

For plants where no excess steam production is required (e.g., stand-alone ammonia producers), the HTER option provides a significant reduction in fuel consumption and in emissions compared to similar plants without HTER. In this case, it is possible to build a steam neutral unit which under normal operation is independent from other parts of the production complex.

Revamp options

The HTER is an obvious choice for capacity enhancement projects in units where the reforming section is a bottleneck for further production increase. The reactor itself requires limited plot space, and Topsoe has several solutions for routing the transfer line from the secondary reformer depending on the placement of the HTER. The reactor is tailor-made for each revamp project in order to utilise the available

pressure drop, which in some cases may be below 1.0 kg/cm².

Topsoe has recently completed the basic design for a revamp of an existing ammonia unit. The target was a 20% increase in ammonia production from the existing unit. The primary reformer design did not allow for this large of an increase in syngas capacity, but with an HTER in parallel, the required target production could be reached in the front-end. An additional ammonia converter and waste heat boiler were also required in the loop, as well as minor modifications to the CO₂ removal process. The final result of the revamp scheme included not only a 20% increase in capacity but also a specific energy reduction for the ammonia unit of 0.16 Gcal/t of NH₃.

The mechanical challenge of inserting the HTER between the secondary reformer and waste heat boiler was solved together with the contractor by doing detailed stress analyses while taking into account the steps and space required during installation.

The plant is also placed conveniently within access to the main transportation route, and there is access for a large crane to lift the pressure shell into place while the plant is in operation. This makes it possible to complete a large part of the installation before turnaround, thus minimising downtime. With proper planning, the installation and commissioning of large pressure vessels can be completed in a remarkably short time; at one customer plant site in India, the erecting, installing and commissioning of an additional ammonia converter was completed in just three weeks after plant shutdown.

If a revamp is combined with an overhaul of rotating equipment and other steam-dependent units, the result will be a net decrease in fuel consumption. The HTER is a particularly good solution for customers who have excess steam production leading to huge energy losses. In one specific case, Topsoe was asked to study the result of including an HTER in an ammonia unit in order to minimise steam production. The reforming section was of a non-Topsoe top-fired design and the study showed that steam production could be reduced by nearly 40% and that the load on the primary reformer could also be reduced (i.e. further reduction in fuel costs).

References

- Barker S, Pach J, Mowbray K and McFarlane K (Johnson Matthey): "Improving catalytic reactor design", written for Nitrogen+Syngas (Apr 2016).
- Pellacani F and Wawretz A (Clariant) and Genova G (Casale): "Exergy efficiency improvements in ammonia production by combined use of Clariant AmoMax®-10 and Casale 3-beds axial-radial reactor", presented at Nitrogen+Syngas 2016, Berlin, Germany (Feb 2016)
- Kelling D and Olesen L (Haldor Topsoe): "Improvements to shift reactor operations based on computational fluid dynamics modelling", presented at Ammonia Safety Symposium, Tucson, Arizona (Sep 2000).
- Biegel C (Agrium) and Morton D (Haldor Topsoe): "Lower cost operation with low pressure drop support grids in HTS and LTS shift reactors", presented at Ammonia Safety Symposium, Boston (Sep 2015).
- Sandberg P. (Haldor Topsoe): "Optimal performance – integration of Haldor Topsoe Heat Exchange Reformer in ammonia plants", presented at 2015 Asian Nitrogen+Syngas Conference, Jakarta, Indonesia (Oct 2015).

Advertisers' index

Advertiser	Page	Contact	Fax / Email
Aumund Holding BV	39	Ms Vera Lambrix	31 77 32 00 728
Casale	9/23	Ms Rosella Gazzaniga	41 91 960 7291
CEAMAG	27	Mr Gerard Malard	33 1 30 68 93 70
Clariant Produkte (Deutschland) GmbH	59	Ms Julie Reinher	julie.reinher@clariant.com
Asian Nitrogen + Syngas Conference	49	Ms Hayley Ward	hayley.ward@crugroup.com
Eurotecnica Contractors and Engineers	5/OBC	Mr Stefano Sassi	s.sassi@eurotecnica.it
Integer Research	31		www.integer-research.com
Johnson Matthey	IFC	Ms Frances Lynch	44 1642 522 542
Kimre Inc	11	Ms Stephanie M Gornail	sgornail@kimre.com
Sabin Metal Corporation	17	Mr Bradford Cook	bcook@sabinmetal.com
Sandvik Process Systems	19	Ms Gundula Eckhardt	49 711 510 114
Schoeller-Bleckmann Nitec	13	Mr Herman Kemberger	43 2630 31919
Stamicarbon	35	Ms Chantal Spies	31 46 4237001

Next issue: July/August 2016

Distribution at: AIChE Ammonia Safety Symposium, Denver, Colorado, USA

- **Ammonia industry incidents** By sharing experiences of incidents in ammonia plants and reporting on the root causes and solutions, recommendations can be made to improve safety and avoid the same scenarios from occurring in the future.
- **Reformer furnace revamps** A selection of case studies of major reformer furnace revamps illustrate how syngas plants can be revamped for increased plant capacity and efficiency.
- **Issues with ammonia transportation** Ammonia transport by rail has faced increasing scrutiny, especially in North America, in the wake of several high-profile rail accidents involving oil and petrochemical products. What are the risks, and are there other options for safe transport of ammonia?
- **Iran and the Gulf** Iran has the largest gas reserves in the world and a major pipeline of ammonia and methanol projects designed to use them which could finally become realised now that there are real prospects for the easing of international sanctions.
- **Feedstock economics** With the major changes in commodity prices over the past few years, from the oil price crash to the changes wrought by shale gas on the natural gas market and the decline in use of coal for power production, the balance between different feedstock economics for syngas production continues to change.

Closing date for advertisement space booking is 1 July 2016

For further information and to book advertisement space contact:

Tina Firman, Publishing Director: tina.firman@bcinsight.com

Tel: +44 (0)20 7793 2567 Fax: +44 (0)20 7793 2577

Editor: RICHARD HANDS
richard.hands@bcinsight.com

Technical Editor: LISA CONNOCK
lisa.connock@bcinsight.com

Contributors:
LAURA CROSS
laura.cross@integer-research.com
MIKE NASH
mike.nash@ihs.com

Publishing Director: TINA FIRMAN
tina.firman@bcinsight.com

Subscription rates:
GBP 425; USD 850; EUR 655

Subscription claims:
Claims for non receipt of issues must be made within 3 months of the issue publication date.

Subscriptions Manager / enquiries:
MARIETTA BESCHORNER
Tel: +44 (0)20 7793 2569
Fax: +44 (0)20 7793 2577
marietta.beschorner@bcinsight.com
Cheques payable to BCInsight Ltd

Advertising enquiries:
TINA FIRMAN
tina.firman@bcinsight.com
Tel: +44 (0)20 7793 2567

Agents:
Japan: (also subscription enquiries)
KOICHI OGAWA
O.T.O. Research Corporation
Takeuchi Building
1-34-12 Takadanobaba
Shinjuku-Ku, Tokyo 169, Japan
Tel: +81 3 3208 7821
Fax: +81 3 3200 2889

Previous articles from Nitrogen+Syngas and Nitrogen & Methanol from 1996 to the present are available digitally in PDF format. To make a purchase, or for a list of available articles, please see: www.bcinsight.com

Copyright: Issued six times per year, or bi-monthly. All rights reserved. No part of this publication may be reproduced, stored in a retrieval system or transmitted in any form or by any means – electronic, mechanical, photocopying, recording or otherwise – without the prior written permission of the Copyright owner.

ISSN: 1750-6891

Design and production:
JOHN CREEK, DANI HART



Printed in England by:
Buxton Press Ltd
Palace Road, Buxton, Derbyshire,
SK17 6AE

© 2016 – BCInsight Ltd

BCInsight

Published by: BCInsight Ltd
Southbank House, Black Prince Road
London SE1 7SJ, England
Tel: +44 (0)20 7793 2567
Fax: +44 (0)20 7793 2577
Web: www.bcinsight.com
www.bcinsightsearch.com

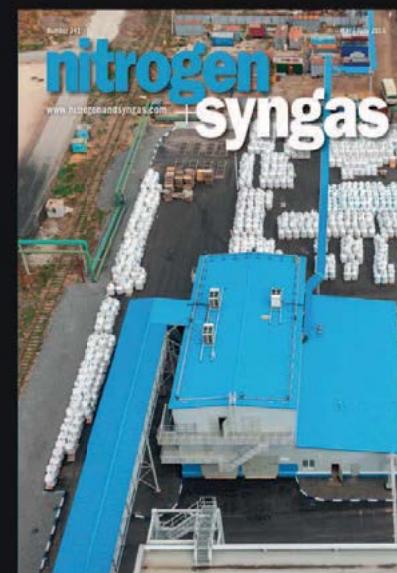
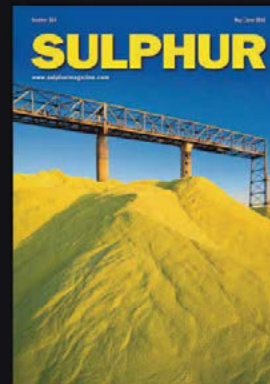

Complete coverage of the international sulphur, fertilizer, related chemicals and raw materials industries in print and online

BCInsight
www.bcinsight.com

CONTENTS

What's in issue 341

COVER FEATURE 1

Long-term fertilizer demand

COVER FEATURE 2

Challenges for India

COVER FEATURE 3

Sulphur-enhanced urea

COVER FEATURE 4

Optimising catalytic reactors

NITROGEN+SYNGAS
ISSUE 341
MAY-JUNE 2016

BCInsight

Southbank House, Black Prince Road
London SE1 7SJ, England
Tel: +44 (0)20 7793 2567
Fax: +44 (0)20 7793 2577
Web: www.bcinsight.com
www.bcinsightsearch.com



Melamine

makes our lives more comfortable

Euromel[®], the trademark of melamine produced at plants licensed by Eurotecnica Group, the leading melamine technology provider since 1978, is the sign of superior melamine quality as witnessed by licensees the likes of QAFCO, MHTL, Grupa Azoty, Petrochina and several others.

Euromel[®] melamine can be found in many objects that surround us, such as dinnerware and household appliances.

Euromel[®] brand is registered in 48 countries representing 85% of the melamine world's consumption.

**WE ARE
MELAMINE
TECHNOLOGY**



Don't forget the next
issue of **Nitrogen+Syngas**
July/August 2016

CONTENTS

What's in issue 341

COVER FEATURE 1

Long-term
fertilizer demand

COVER FEATURE 2

Challenges
for India

COVER FEATURE 3

Sulphur-enhanced
urea

COVER FEATURE 4

Optimising
catalytic reactors

NITROGEN+SYNGAS
ISSUE 341
MAY-JUNE 2016

BCInsight

Southbank House, Black Prince Road
London SE1 7SJ, England

Tel: +44 (0)20 7793 2567

Fax: +44 (0)20 7793 2577

Web: www.bcinsight.com
www.bcinsightsearch.com