

1  
2  
3  
4  
5  
6  
7  
8  
9  
10  
11  
12  
13  
14  
15  
16  
17  
18  
19  
20  
21  
22  
23  
24  
25  
26  
27  
28  
29

# Welcome to our interactive version of **Fertilizer International** Issue 469

Please use either the buttons on the left or top right of the page to navigate your way around this interactive PDF

#### IMPORTANT INFORMATION:

Copyright – Issued six times per year, or bi-monthly. All rights reserved. No part of this publication may be reproduced, stored in a retrieval system or transmitted in any form or by any means – electronic, mechanical, photocopying, recording or otherwise – without the prior written permission of the Copyright owner.

Number 469

November | December 2015

# INTERNATIONAL **Fertilizer**

[www.fertilizerinternational.com](http://www.fertilizerinternational.com)

**Citrus fertilisation**

**Pakistan's fertilizer industry**

**Phosphorus recovery finally breaks through**



CONTENTS

What's in issue 469

COVER FEATURE 1

Citrus fertilisation

COVER FEATURE 2

Pakistan's fertilizer industry

COVER FEATURE 3

Phosphorus recovery finally breaks through

FERTILIZER INTERNATIONAL  
**ISSUE 469**  
NOVEMBER-DECEMBER 2015

**BCInsight**

Southbank House, Black Prince Road  
London SE1 7SJ, England  
Tel: +44 (0)20 7793 2567  
Fax: +44 (0)20 7793 2577  
Web: [www.bcinsight.com](http://www.bcinsight.com)  
[www.bcinsightsearch.com](http://www.bcinsightsearch.com)



Seeking Global Agents,  
 anytime,  
 anyplace, any items.....



Monband, since 1995, started from the services of agricultural technology, established in 2009, now has plant covering 41,000 square meters, more than 300 employees and annual output of 100,000mts and is one of the leading and professional manufacturers of water soluble fertilizers in the world.



**Local/International Sales Representative**  
 Qualifications:

- 1 Extensive work experience in fertilizer industry/organization
- 2 Excellent language skills: local language & English
- 3 At legal working age
- 4 Attractive salary package, treatment interviews

Please send us your resume in English to [info@jitainy.com](mailto:info@jitainy.com).  
 See details at [www.monband.com](http://www.monband.com) or call +86 311 80959693.



Hebei Monband Water Soluble Fertilizer Co., Ltd.  
 TEL: +86 (0)311 80959693 FAX: +86 (0)311 80959682  
[www.monband.com](http://www.monband.com)

Director Peter Li Likeqiang@jitainy.com | India, Latin America, South & North America David Zhang Davidzhang@jitainy.com | Asia and Europe, Turkey, Lebanon John Wei Johnwei@jitainy.com | Oceania, Africa and Middle-east Michael Zhang Zhanglei@jitainy.com



Cover: Citrus fruit ripening on a tree. Janaph/Shutterstock.com

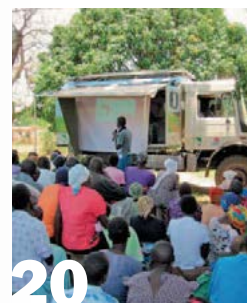

Ugandan agriculture



FSU potash

Read this issue online at:  
[www.fertilizerinternational.com](http://www.fertilizerinternational.com)

Published by:  
**BCInsight**

# Fertilizer INTERNATIONAL

[www.fertilizerinternational.com](http://www.fertilizerinternational.com)

NUMBER 469

NOVEMBER | DECEMBER 2015

## CONTENTS

- 7 Citrus fruits: a lucrative segment**  
 A combination of factors makes citrus fruit an attractive market for fertilizer suppliers. We examine the nutrient needs of citrus trees and how balanced application of fertilizers helps maximise citrus fruit quality and yield.
- 11 Ammonium sulphate heads from east to west**  
 Large ammonium sulphate export volumes out of China are reversing established trade flows. Despite this market shake up, premium pricing continues to make ammonium sulphate supply an attractive proposition in some regions.
- 13 Finishing with emissions**  
 Increasingly stringent emissions regulations have demanded major improvements to the scrubbing of out-gases from nitrogen plants in recent years. Some notable examples of the latest and most effective dust emissions and ammonia abatement technologies are described.
- 17 Asia's most resilient producer**  
 Pakistan's fertilizer sector is a modern, nine million tonne capacity industry. The country has reacted to strong domestic fertilizer demand by making major investments in new and revamped plant capacity. We report on fertilizer production in Pakistan and its resilience in the face of natural gas curtailments.
- 20 The Growth for Uganda project**  
 K+S KALI GmbH has been providing thousands of Uganda's farmers with fertilisation training as part of a joint project with the Sasakawa Africa Association. K+S KALI report on the project's achievements to date.

## PHOSPHATES AND POTASH INSIGHT

- 22 Phosphorus recovery finally breaks through**  
 The installation of a struvite harvesting system at the world's largest wastewater treatment plant in Chicago, Illinois, demonstrates the increasing viability of phosphorus recovery. We look at the effectiveness and economic merits of the main technology options for P recovery.
- 25 Massive FSU investments, falling costs**  
 Three of the four major greenfield potash projects likely to enter production globally in the next five years are located in the Former Soviet Union. We review the potash investments of existing major producers and ambitious new market entrants in the region.

## REGULARS

- 3 Editorial**  
 How not to kill the market
- 4 Market Outlook**
- 5 Industry News**
- 7 People & Diary**
- 28 Index to advertisers**

## CONTENTS

What's in issue 469

## COVER FEATURE 1

Citrus fertilisation

## COVER FEATURE 2

Pakistan's fertilizer industry

## COVER FEATURE 3

Phosphorus recovery finally breaks through

FERTILIZER INTERNATIONAL  
**ISSUE 469**  
 NOVEMBER-DECEMBER 2015

**BCInsight**

Southbank House, Black Prince Road  
 London SE1 7SJ, England  
 Tel: +44 (0)20 7793 2567  
 Fax: +44 (0)20 7793 2577  
 Web: [www.bcinsight.com](http://www.bcinsight.com)  
[www.bcinsightsearch.com](http://www.bcinsightsearch.com)

# How not to kill the market



As a first-time attendee, I very much enjoyed TFI's World Fertilizer Conference in Boston at the end of September. But several fellow delegates did remark on the event's subdued and sombre mood compared to previous years.

Hardly surprising then to later discover that the conference's first day coincided with the calamitous 30% crash in Glencore shares. The FTSE 100 lost 100 points that day and Wall Street followed suit, with the Dow ending more than 300 points down at the close.

Keen observers had seen this coming with Bloomberg warning as early as July that mining stocks were being lined-up as the latest victims of a commodity rout. "We're probably not too far off a global industrial recession," warned a gloomy Colin Hamilton, head of commodities research at Macquarie Group. "The only thing that can turn it around are strong capacity cuts."

Some analysts have been predicting since the start of the year that the accelerated decline in oil prices in late 2014 would inevitably pull down key industrial and energy commodities with it. Petrochemicals have continued to face bleak news in recent months. In October, ICIS reported a sharp downward fall in its global petrochemical index, as benzene prices crashed and olefins prices weakened.

So are fertilizers destined to join the general commodities slide, or is the industry reassuringly immunised from contagion, sheltered by a unique and separate set of market idiosyncrasies? Well, the following phrases in our current issue tell their own story: production cuts, lower volumes, weaker prices, currency volatility, oversupply, challenging conditions, lacklustre markets.

Interesting, then, that the other watchword this issue is discipline. Mosaic's CEO, Joc O'Rourke, spoke of the need to match production levels to demand, saying now was "a time for leadership... and maintaining our discipline" (p8). Speaking about the risks of oversupply in the potash market, EuroChem's mining head, Clark Bailey, also commented that "disciplined companies will not kill the market" during our exclusive *Fertilizer International* interview (p52).

Fertilizer supply and demand, as with other commodities, are rarely in balance. Instead, the two are in a constant race in which with one catches and overtakes the other, only to inevitably fall back and lose the lead once more. Because of

this, the overcapacity behind much of current price weakness has its origins – you guessed it – in stronger prices previously, as the World Bank makes clear in its October commodity markets outlook. "Fertilizer prices are expected to contract on weak demand and excess capacity expansion due to earlier high prices," it notes.

The World Bank's latest outlook does not make for happy reading. It expects a 5% overall decline in fertilizer prices in 2015 because of weak demand, rising supply and destocking.

The bank's 2015 fertilizer price index has also fallen to 95% of 2010 levels – a pricing level that may remain unchanged next year. Fertilizer price falls in the second and third quarter of this year, according to the bank, were due to excess supply and weak import demand.

Excess supply is being exacerbated by falling costs, cheaper feedstock prices and currency declines in key producing countries. Lacklustre demand, says the World Bank, stems from declining farm purchasing power, lower agriculture commodity prices and currency depreciation in major agricultural economies. If this wasn't bad enough, adverse weather from El Niño may depress agriculture production and fertilizer demand in Asia further.

So what is the intelligent industry response to this softening market? Mosaic, PotashCorp and Belaruskali have all confirmed temporary cutbacks in capacity for the final quarter of the year. Other big producer may – or may not – follow suit. Such decisions are always a dilemma as no producer wants to voluntarily cede hard-won market share to its competitors. In essence, that means the need for production discipline has to be widely-shared if it is to have any effect.

In a sector where bringing a major greenfield project to fruition can take up to nine years, wise fertilizer industry players are always looking towards the future. So the fact that moderate price increases still look likely over the medium term – spurred by demand growth, higher energy costs and the underlying need for new capacity – will surely steady nerves as one year ends and another begins. ■

S. Immanuel

STAMI UREA



## A FULL LIFE-CYCLE PHILOSOPHY FOR SUSTAINABLE BUSINESS

Stamicarbon's engagement and commitment to urea plant owners doesn't stop after signing the contract and building the plant. Based on decades of experience in meeting the needs of a diverse range of customers, we have built up the insight and expertise to support you through the whole life cycle of your plant. Regardless of the stage your plant is at, we offer you reliable tailor-made technology solutions, products and services that match your needs and increase production in a sustainable way. With three proven solutions, LAUNCH®, ADVANCE® and EVOLVE®, we can address all your questions and requests.

For more information contact Stamicarbon B.V., The Netherlands, visit [www.stamicarbon.com](http://www.stamicarbon.com) or email [communication@stamicarbon.com](mailto:communication@stamicarbon.com)



**LAUNCH®**  
Creating your plant

Launch a new plant with all technologies, products and services needed for successful, sustainable and profitable urea production.

**ADVANCE®**  
Optimizing your plant

Advance your plant performance with products and services to support and train plant staff and improve equipment and product quality to stay competitive.

**EVOLVE®**  
Upgrading your plant

Evolve your plant to the next level with revamp and debottlenecking to increase production capacity and reduce energy consumption and emissions.

The innovation & license company of Maire Tecnimont.



CONTENTS

What's in issue 469

COVER FEATURE 1

Citrus fertilisation

COVER FEATURE 2

Pakistan's fertilizer industry

COVER FEATURE 3

Phosphorus recovery finally breaks through

FERTILIZER INTERNATIONAL  
**ISSUE 469**  
NOVEMBER-DECEMBER 2015

**BCInsight**

Southbank House, Black Prince Road  
London SE1 7SJ, England  
Tel: +44 (0)20 7793 2567  
Fax: +44 (0)20 7793 2577  
Web: [www.bcinsight.com](http://www.bcinsight.com)  
[www.bcinsightsearch.com](http://www.bcinsightsearch.com)

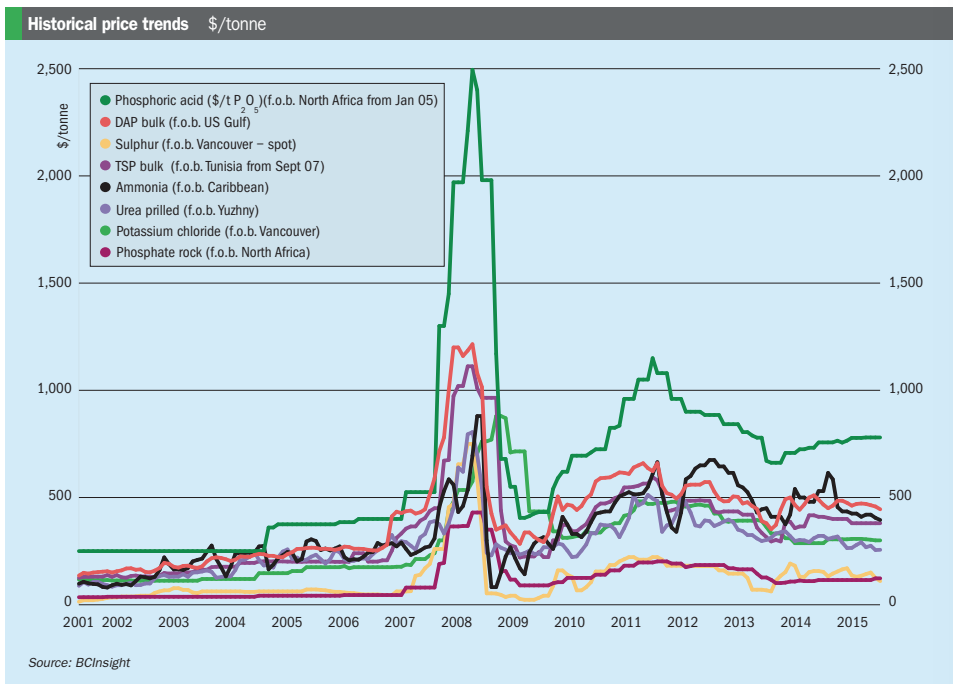

## Market insight courtesy of Integer Research

### AMMONIA

Demand is weak on the global ammonia market, with comparatively few deals concluded in September and the first half of October. Ammonia availability also continues to be restricted, with several plants in North Africa and the Black Sea regions shut throughout September due to outages and maintenance intervals. To some extent, this has counteracted downward pressure on price levels, with prices ticking up across the board in September, with the exception of the US. However, the impact of sluggish demand kicked in again in the first half of October, when prices started to edge down once more to \$390-400/t f.o.b. Black Sea.

### UREA

Urea prices tumbled down to \$250/t f.o.b. Black Sea in late October amidst a market that continues to be oversupplied. Demand was weak and the market quiet in September and October, with the exception of two Indian tenders issued in late September

and mid-October. The devaluation of the Chinese yuan rendered Chinese exports even more competitive. With worries about the continuing price drop, the Chinese Nitrogen Fertilizer Industry Association (CNFIA) warned of “serious ramifications” for Chinese suppliers accepting lower price ideas. Most suppliers are reportedly aiming to hold prices above \$250/t f.o.b. during negotiations for the latest Indian tender.

### PHOSPHATES

Limited demand from Indian DAP and Latin American MAP buyers weighed heavily on the market in the third quarter. In India, monsoon rainfalls remained at lower-than-expected levels over the period, slowing crop plantings and dampening associated fertilizer demand. The weak rupee also exacerbated the situation by increasing the comparative cost of fertilizers and raw materials imports. The Brazilian market remains hamstrung by its own domestic financial troubles, with little apparent respite on the horizon. Consequently, average delivered prices for DAP to

India in the third quarter were down by \$13/t on the previous quarter to \$480/t cfr, and similarly down by \$10/t to \$476/t cfr for MAP deliveries to Brazil.

All benchmarks recorded lower average quarter-on-quarter f.o.b. prices, reflecting the general lack of global phosphate market activity. In response to the bearish market sentiment, major North American producer Mosaic announced in September that it would be slowing phosphates production, while Morocco’s OCP was also rumoured to be considering cutbacks.

### POTASH

The bearish sentiment in the potash market also worsened in the second half of the year, as prices continue to soften in most regions. There was further weakening in Latin and North America, in the Middle East and in Asia during September, stemming from low levels of demand and currency volatility. The granular potash markets of Brazil and the United States have been the most disappointing. Prices in Brazil are some \$50/t lower than at the start of the year at \$300/t cfr and continue to drift downwards.

In the US, oversupply in the New Orleans barge market continues to pressure prices, which have been heard at \$270-275 per short ton f.o.b. In Southeast Asia too, buyers have taken to the side-lines, as volatile currencies temper import demand and tenders from major oil palm plantations are awaited. Standard MOP prices have slipped to \$295-310/t cfr.

### SULPHUR

Global sulphur prices collapsed over the past month. Bearish sentiment is holding

back both fresh purchasing activity and fourth quarter contract price negotiations. The lack of confidence in the market has come on the back of weak macroeconomic conditions. Commodity prices slumped as currency devaluations took a toll on markets such as China. Weak phosphate product demand in the US and Brazil has also triggered cutbacks in phosphate production and an easing in sulphur consumption. Sulphur spot prices dropped in China to around \$120-130/t cfr in mid October, while Middle East producers also reduced monthly con-

tract price postings. In Saudi Arabia, Aramco Trading’s October price was announced at \$123/t f.o.b. Jubail, down \$27/t on September, a clear indication of price pressure in the market. Sulphur stocks in China have been fluctuating around the one million tonne mark. This is a sign of a shorter term buying strategy in the market, and is adding to the uncertain outlook as low stock levels no longer signal a potential boost in prices. China’s sulphur imports do, however, show a slight uptick on a year earlier, despite the more bearish sentiment.

### Market price summary \$/tonne – Late-October 2015

Nitrogen	Ammonia	Urea	Ammonium Sulphate	Phosphates	DAP	TSP	Phosphoric Acid
f.o.b. Caribbean	380	n.m.	f.o.b. E. Europe 110-115	f.o.b. US Gulf	430-440	n.m	n.m
f.o.b. Yuzhny	380-385	257-262	-	f.o.b. N. Africa	480-485	368-390	720-840
f.o.b. Middle East	450-460	248-265**	-	cfr India	435-440	-	810*
Potash	KCl Standard	K <sub>2</sub> SO <sub>4</sub>	Sulphuric Acid		Sulphur		
f.o.b. Vancouver	290-310	-	cfr US Gulf	45-55	f.o.b. Vancouver	105-115	
f.o.b. Middle East	285-310	-			f.o.b. Arab Gulf	120-125	
f.o.b. Western Europe	-	€490-520			cfr North Africa	145-150	
f.o.b. FSU	272-295				cfr India	135-145+	

Prices are on a bulk, spot basis, unless otherwise stated. (\* = contract \*\* = granular). Phosphoric acid is in terms of \$/t P<sub>2</sub>O<sub>5</sub> for merchant-grade (54% P<sub>2</sub>O<sub>5</sub>) product. Sulphur prices are for dry material. (+ Quotes for product ex-Arab Gulf) Copyright BCInsight

### MARKET DRIVERS

- Ammonia outlook:** Supply is expected to remain tight in several regions beyond October. Although there is limited availability from Russia, Ukrainian producers are expected to step in and resume production after gas supply issues were resolved. Nevertheless, tight supply could provide some support for Black Sea prices, while prices in other regions are expected to fall further in the short term. Market expectation is, however, that prices will edge up again in November, if expected refill demand from the US creates fresh buying interest, particularly for Black Sea ammonia.
- Urea outlook:** Ample supply and a lack of emerging demand leaves room for further urea price falls during November. Despite resistance, high inventory levels at Chinese ports are expected to eventually lead to traders lowering their price ideas. Although Chinese urea prices are close to their floor, and cannot fall much further without becoming unprofitable, sluggish demand and ample global supply makes further decreases likely in the short term. Entry onto the market of additional supply from North Africa and
- Phosphates outlook:** We expect the phosphates market to remain lacklustre in the fourth quarter with limited activity. There is little to suggest prices will deviate much from current levels, although seasonal markets such as Australia may lend some price support. The Chinese market will remain oversupplied as domestic demand has largely been covered and export demand is likely to be minimal. Indian buyers will be in no hurry to secure additional volumes, as most requirements have been met by previous purchases. Indian farmers may, however, return to market from December to purchase for the *Rabi* season. Brazilian buyers are unlikely to make a significant return to the market until *Safrinha* purchases in the New Year.
- Potash outlook:** The final quarter of 2015 is expected to be particularly challenging. The market remains oversupplied, with only one producer – Mosaic – formally announcing curtailment of MOP output. Capacity at Uralkali has been lower in 2015 due to the flooding of Solikamsk-2. But the company has adjusted and overall MOP output in July-September was only down 200,000

tonnes year-on-year. Indian import volumes may be slightly down on 2014 due to devaluation of the rupee. Indian buyers are also pressing for a discount on the 2015/16 potash contract price, currently at \$332/t cfr for India. A downward correction is also expected when Chinese buyers begin 2016 contract negotiations. A correction of \$15 would bring contracts down to \$300/t cfr, although this may still be too optimistic.

**Sulphur outlook:** Looking ahead, downward pressure from new sulphur supply sources across the oil and gas sectors is expected to remain a core theme. This factor, coupled with the capacity for long-term sulphur storage, will be critical as the global balance shifts from a deficit/balanced situation to a potential surplus. The Shah gas project in the UAE is now running at around 25% of capacity, with exports thought to be mostly moving to Morocco. Sulphur prices are expected to reach a floor and stabilise, before any potential price recovery. Mosaic’s new one million t/a sulphur remelter project is on schedule for commissioning in the last quarter, and is likely to have a significant impact in the coming months, if utilisation rates are high.

**NORTH AMERICA**

## Potash Corp and Mosaic cut production

PotashCorp has announced a 500,000-tonne cut in fourth quarter potash production in response to poor market conditions. The scale-back will see the permanent closure of the Penobsquis, New Brunswick potash mine and inventory shutdowns at the Cory, Allan and Lanigan mines in Saskatchewan during December.

"Market concerns have weighed on customer sentiment, contributing to a weaker fertilizer environment in the second half of 2015. While we anticipate production in the fourth quarter to be reduced by nearly 500,000 tonnes, we do not expect employee layoffs," said Jochen Tilke, PotashCorp's president and CEO.

Tilke made the comments in response to the company's third quarter results released on 29 October. PotashCorp's 2015 third quarter net income, gross margin and total sales all fell year-on-year.

North American potash shipments this year are expected to remain below 2014 levels. The company has also lowered its outlook for Chinese and Indian potash deliveries. Latin American shipments, although likely to be down on last year's record levels, are predicted to remain strong by historical standards.

"We have lowered our sales volume guidance to a range of 9-9.2 million tonnes and now expect potash gross margin of \$1.4-\$1.5bn, reflecting weaker volumes and prices," PotashCorp said in a statement.

PotashCorp's curtailment of potash production in the final three months of the year follows a similar announcement by Mosaic on 21 September.

Mosaic intends to reduce its potash pro-

duction by extending maintenance downtime at its Colonsay, Saskatchewan mine – and is also proceeding with a planned slowdown in phosphates production. Both moves are in response to current market conditions, particularly delayed Brazilian and North America fertilizer purchases.

Domestic and international fertilizer markets have been softening since the start of August, reports Mosaic. Currency volatility, lower grain and oilseed prices and declines in the global equity market have all contributed to lower volumes and weaker price for fertilizers in recent months.

"The long-term positive outlook for crop nutrient demand has not changed, but the industry faces some near-term challenges in the current environment. It is a time for leadership, and we are managing our production levels to match current demand, controlling our costs, and maintaining our discipline," said Joc O'Rourke, Mosaic's president and CEO.

Mosaic's phosphate and potash third quarter volumes are both expected to be at the lower end of the previously forecast ranges of 2.1-2.4 million tonnes and 1.6-2 million tonnes, respectively.

There are signs that other major phosphate and potash producers are also tailoring production to match sluggish market conditions. Belaruskali is reducing potash production from 70% to 65% of capacity during November and December, for example. It had planned to increase output this year but is now predicting flat production and lower exports. Morocco's OCP is also reported to be moving some of its maintenance activity into the fourth quarter. ■

## UN formally adopts SDGs

IFA Chairman, Abdulrahman Jawahery, has praised world leaders for formally adopting Sustainable Development Goals (SDGs) at the United Nations summit in New York at the end of September.

"The SDGs adopted today – following many years of productive and inclusive dialogue – set an important roadmap for the entire international community to pursue sustainable development," he said. "This represents an impressive achievement, and the onus is now on all of us to roll

up our sleeves and implement these ambitious but feasible goals."

The SDGs come into effect next year, replacing the current Millennium Development Goals, and will run to 2030. IFA has welcomed the emphasis placed by SDGs on sustainable agricultural production, the access of smallholder farmers to inputs, investment in rural infrastructure and support for agricultural research and extension services.

"Plant nutrients – of organic and mineral nature – contribute to many of the 17 SDGs, but of course mainly to Goal 2

on eradicating hunger and malnutrition," said IFA Director General Charlotte Hebebrand. "Balanced and correct fertilizer use plays an important role in sustainable agricultural intensification, which allows for greater productivity and a wiser use of limited natural resources, and also minimizes nutrient losses to the environment, including to the world's oceans, as highlighted in Goal 14."

IFA's delegation to the SDG Summit and the UN Global Compact Private Sector Forum included Tip O'Neill, CEO of International Raw Materials Ltd, Svein Tore Holsether, CEO of Yara, and Barrie Bain, Senior UN Adviser, who attended on behalf of IFA's Secretariat. Following the formal ratification, attention will now turn to SDG indicators. These are still under negotiation in a process overseen by the UN High Level Political Forum.

## Mosaic invests \$800m in environmental stewardship

Mosaic is setting aside \$800 million for waste management and long-term phosphogypsum stack aftercare, as part of an agreement with US federal and state environmental regulators.

A \$630m trust fund will be set up "as financial assurance to support the closure and long-term care of phosphogypsum stack systems", Mosaic said. A further \$170 million has been earmarked for waste management, waste recovery and increased uses of by-products. Mosaic does not expect production levels to be adversely affected by either of these new investments.

To cover past environmental lapses, Mosaic will also pay an \$8 million penalty and spend \$2.2 million on two environmental projects in Florida and Louisiana, as part of the agreement with regulators.

"Mosaic is committed to meaningful environmental stewardship at all of our facilities, and we take our responsibility to be good corporate citizens – now and for the decades ahead – very seriously," said Joc O'Rourke, Mosaic's president and CEO. "The commitments we are making through these settlements further those stewardship efforts," he added.

The environmental agreement with US authorities is subject to final court approval.

## EuroChem buys Ben-Trei

EuroChem has successfully completed its acquisition of Oklahoma-based Ben-Trei

Fertilizer Co through its subsidiary, EuroChem Trading USA.

The purchase brings with it Ben-Trei's valuable marketing and distribution network covering Texas, the Louisiana delta, the Midwest Corn Belt and California. Ben-Trei has been selling and distributing fertilizers in the US for nearly three decades and so far this financial year has sold one million short tons of fertilizer to over 500 customers in North America.

Commenting on the deal, EuroChem CEO Dmitry Strezhev said: "With its strategically-located assets and vast customer network, the acquisition of Ben-Trei also brings valuable market intelligence and a strong team to bolster our growing US presence."

EuroChem has been selling fertilizers in the US through its Tampa-based subsidiary since 2006. US buyers accounted for 8% of EuroChem's total sales last year.

## PotashCorp withdraws K+S offer

PotashCorp has withdrawn its proposal to buy K+S KALI GmbH at a price of €41 per share. Declines in global commodity and equity markets, and a 40% fall in some potash stocks, were behind the decision to rescind the \$8.9 billion takeover deal.

"Our proposal reflected full and fair value," said Jochen Tilke, PotashCorp's president and CEO. "In light of these market conditions and a lack of engagement by K+S management, we have concluded that continued pursuit... is no longer in the best interests of our shareholders."

PotashCorp's offer to buy K+S was rejected by the German potash producer's board on two separate occasions, despite the urging of some K+S shareholders (*Fertilizer International*, 467 p9). A hostile takeover attempt by PotashCorp had been thought a likely next move. But recent prices falls now mean this is no longer a viable option for the Canadian fertilizer giant.

"This step creates clarity. We are convinced that we can successfully develop our company based on a consistent implementation of our two-pillar strategy in the long term. We are strong in potash and in salt," said Norbert Steiner, K+S chairman, in reaction to the news.

## MOROCCO

### OCP rules out foreign investment

The Moroccan government has denied that OCP, the 95% state-owned phosphate giant, might accept outside investment.

Sources told the Moroccan news agency *Hespress* that: "The Moroccan government which maintains major control of the company did not take such a decision and is not even considering it."

The sources added that OCP would only consider foreign investment "under exceptional circumstances" and that reports claiming otherwise were speculative.

The denial rebuts earlier hints from OCP's leadership that it was open to all financing options in pursuit of the firm's multibillion dollar investment strategy. CEO, Mostafa Terrab, was reported to have

been open-minded about the possibility of a future share offer during an interview in London in September.

"There is one key red line; the Moroccan state will always maintain majority control," Terrab said. "Other than that, we are open to all financing options that advance our strategy and protect our shareholders' interest."

OCP is currently partway through a massive \$20 billion investment to double mining output and triple fertilizer production by 2025, having spent \$4 billion to date. The company retains Rothschild as its financial adviser.

## A BETTER WAY TO CORRECT MICRONUTRIENT DEFICIENCIES

Feed crops more effectively with Wolf Trax® Innovative Nutrients from Compass Minerals. Using EvenCoat™ Technology and PlantActiv™ Formulation, Wolf Trax Innovative Nutrients do a better job of delivering important nutrients when they are needed most. It's better nutrition for better crops and better farming.



**Granular Micronutrient**  
Traditional granular application results in sparse and inconsistent distribution of the micronutrient.



**Wolf Trax DDP Nutrients**  
Coating every fertilizer prill results in dramatically improved distribution of the micronutrient.



**EvenCoat™ Technology**  
Wolf Trax DDP™ EvenCoat™ Technology allows the nutrient to thoroughly and evenly coat each prill of dry fertilizer in a blend, ensuring nutrients are distributed throughout the root zone and providing up to 50 times the interception points for easier and earlier access to nutrients.



Fertilizer coated with Wolf Trax Iron DDP



**PlantActiv™ Formulation**  
Wolf Trax DDP Nutrients are chemically and physically designed for better availability to plants. The unique formulation helps nutrients avoid soil tie-up and remain plant-available longer.

wolftrax.com +1 913 344 9354

©2015 Wolf Trax®, PlantActiv™, EvenCoat™ and DDP™ are trademarks of Compass Minerals Manitoba Inc. Compass Minerals is the proud supplier of Wolf Trax Innovative Nutrients. Not all products are registered in all areas. Contact wolftrax@compassminerals.com for more information.



## CONTENTS

What's in issue 469

## COVER FEATURE 1

Citrus fertilisation

## COVER FEATURE 2

Pakistan's fertilizer industry

## COVER FEATURE 3

Phosphorus recovery finally breaks through

FERTILIZER INTERNATIONAL  
**ISSUE 469**  
NOVEMBER-DECEMBER 2015

# BCInsight

Southbank House, Black Prince Road  
London SE1 7SJ, England  
Tel: +44 (0)20 7793 2567  
Fax: +44 (0)20 7793 2577  
Web: www.bcinsight.com  
www.bcinsightsearch.com

## BRAZIL

## Yara injects \$185m into Salitre phosphate project

Norwegian fertiliser giant Yara International is to invest \$185m in the greenfield Salitre phosphate project in Minas Gerais state, Brazil. The payment, which was conditional on the project's progress, delivers on an agreement made by Yara at the time of its 60% part-acquisition of Galvani last December. The investment by Yara also depended on confirmation of the project's phosphate reserves.

The payment consists of a \$96 million deferred consideration, a \$54 million Yara capital injection and a \$36 million capital injection on behalf of the minority owners. The 1.2 million t/a Salitre venture is one of three phosphate projects currently being developed by Galvani in Brazil.

## Anglo American ponders phosphate sell-off

Anglo American is weighing up the sale of its Brazilian niobium and phosphate business, a deal that could fetch up to \$1 billion, according to *Bloomberg*.

Anglo has yet to confirm a possible sell-off, but has been selling other assets as it seeks to cut costs and lower debt in response to the collapse in commodity prices. The company has already raised around \$2 billion this year from the sale of two copper mines in Chile, a portfolio of South African platinum assets and its 50% stake in Lafarge-Tarmac.

Anglo merged its Brazilian nickel, niobium and phosphates operations into a single division in 2013 and relocated offices from São Paulo to Belo Horizonte as part of this reorganisation. The company's phosphate operations in Brazil produced 513,000 tonnes of fertilizers in the first half of 2015 and recorded an operating profit of \$52 million over this period.

## B&amp;A starts thermophosphate production

B&A Mineracao began producing calcined thermophosphates from its small-scale Bonito project in Brazil in September. The 150,000 t/a plant produces a 22-23% grade ( $P_2O_5$ ) product for the domestic fertilizer market and has sufficient phosphate ore reserves for 15 years of production.

Thermophosphate production is no longer common, mainly because it is energy-intensive and yields a fertilizer

with a lower nutrient content than standard MAP or DAP. However, the heat-based manufacturing process does not require sulphuric and phosphoric acid and is also less sensitive to rock quality.

Phosphate production can be viable on a smaller-scale in Brazil because of strong import demand in the country. Bonito also benefits from the backing of industrial group AGN Participacoes and the financial group BGN Pactual.

## AUSTRALIA

## Yara takes 100% stake in Pilbara ammonia plant

Yara has increased its ownership of the Pilbara ammonia plant in Australia to 100% after purchasing Apache's remaining 49% stake in the Burrup Peninsula operation for \$391 million. The 850,000 t/a capacity plant has been out of service due to a technical issue but is expected to restart in November.

The purchase also includes Apache's 10% stake in Yara Pilbara Nitrates Pty Ltd (YPNPL), the firm developing a 330,000 t/a technical ammonium nitrate plant that is due to start production early next year. This increases Yara's total stake in YPNPL to 55%, leaving co-owner Orica with a 45% stake.

"The Pilbara assets are already operated by Yara – and therefore require limited efforts to fully integrate," commented Svein Tore Holsether, Yara's president and CEO.

## FINLAND

## Yara mothballs Sokli phosphate project

Yara International has halted development of its Sokli phosphate mining project in Finland, blaming a shortfall in expected profits from the venture.

The preliminary decision to halt the project was "due to the anticipated profitability of the project being below Yara's requirement", the company said in a statement on 24 September.

Yara has invested 18.5 million (\$21 million) in Sokli to date and was planning to produce 1.54 million t/a phosphate and 300,000 t/a of iron concentrate by developing the project. The Sokli apatite deposit is reported to contain 12.2 billion tonnes of hard rock ore and a further 190 million tonnes soft rock ore.

The company will still go-ahead and seek environmental and mining permits for Sokli and has the option of resurrecting the project at a later date.

## JORDAN

## APC plans quarter million tonne output boost

The Arab Potash Company (APC) is to invest \$1 billion increasing its MOP output by 245,000 t/a over the next two to three years, according to *Bloomberg*.

Increasing production by this volume would boost APC's potash output by over 10%. The Jordanian producer manufactured 2.1 million tonnes of MOP in 2014 and 1.7 million tonnes in the first nine months of this year.

Details of the investment were contained in an e-mail from APC chairman, Jamal Al Sarayeh. This also revealed that APC will press ahead and complete a 33 MW solar electricity project over the next two years.

## CHINA

## ICL closes Yunnan Phosphate deal

ICL China has finalised its 50:50 joint venture with Yunnan Phosphate Chemicals Group Corp Ltd. This closes an original agreement signed by the two parties last December, and increases ICL's access to low-cost phosphate rock and phosphoric acid in the Far East.

Both partners look set to invest a total of \$340 million in a new integrated phosphate fertilizer complex in China over the next five years. Investments include a five million t/a phosphate rock mine and 700,000 t/a of phosphoric acid capacity. The venture is also planning to produce 850,000 t/a of MAP and TSP, 120,000 t/a of specialty fertilizers and 65,000 t/a of industrial and feed phosphates in future.

ICL's existing specialty phosphates business in China will be integrated into the new joint venture.

## SAUDI ARABIA

## Ma'aden issues Waad Al Shamal update

Fresh details about progress at Ma'aden's landmark Waad Al Shamal project were released by the company in October.

The project's ammonia plant is now almost 75% complete and its sulphuric acid plant 61% complete. Work on the DAP plant is 43% finished while phosphoric acid plant construction has moved to 62% completion. Around 38% of the project's ore beneficiation plant has also been built so far.

The details were revealed by Ma'aden in a stock exchange statement in late October. The Waad Al Shamal project, a joint venture between Ma'aden (60%), Mosaic (25%) and SABIC (15%), is due to be commissioned next year and enter production in the second half of 2016.

## LAOS

## Potash project construction underway

Construction has begun on a potash project in the Nongbok district of Khammouane province in Laos. The Vietnamese and Laotian prime minister, Nguyen Tan Dung and Thoosing Thammavong, both attended the ground breaking ceremony for the high-prestige project in September.

The Vietnam National Chemical Group (Vinachem) is reportedly contributing \$105 million towards the 320,000 t/a capacity potash project, a joint venture between Vinachem and Viet Lao Chemical and Rock Salt Co (Vilachemsalt). Both firms are contracted to carry out engineering procurement and construction work on the project.

The \$522 million Laos project is said to be one of the largest outside investments ever made by Vietnamese business.

## RUSSIA

## NChG agrees nitrogen plant gas supply deal

National Chemical Group (NChG) has signed a natural gas supply agreement with Gazprom for its new Nakhodka nitrogen complex in Russia's Primorsky region. Gazprom subsidiary Mezhhrengioz will supply the site with around 3.15 billion cubic metres of gas annually for 20 years as part of the deal.

Located in far eastern Russia, the Nakhodka complex is scheduled to begin production in 2019 and will eventually produce two million t/a of urea, 1.1 million t/a of ammonia and one million t/a of methanol, when it ramps up to full capacity by 2021. The construction of a nearby port terminal will allow the export of fertilizers to India, Southeast Asia and Latin America.

The new plant should increase NChG's ammonia capacity by around 20% to 2.1 million t/a and help diversify its fertilizer product range. The company currently produces ammonia, ammonium nitrate, nitric acid and NPK fertilizers through its subsidiary Minudobrenia.

## TogliattiAzot wins Taman terminal approval

TogliattiAzot has received permission to build its Taman ammonia and urea export terminal. This is strategically located in Russia's Krasnodar region at the entry to the Sea of Azov.

The terminal will provide TogliattiAzot with the capacity to export two million tonnes of ammonia and three million tonnes of urea annually, once completed. TogliattiAzot is financing the whole of the \$300 million project itself.

The new terminal is designed to accept 50,000 tonne deadweight vessels and is due to begin exporting ammonia in 2017 when the first phase of construction is completed. The ability to export urea will follow in 2020 on completion of the terminal's second phase. TogliattiAzot is expected to export ammonia through Taman as an alternative to Yuzhny.

## EuroChem wins \$140 million in Swiss courts

EuroChem was awarded a \$140 million settlement by the Swiss Arbitration Court in a claim against Shaft Sinters over work at the company's VolgaKaly potash project in Russia.

A three-member arbitration panel judged that Shaft Sinters "deliberately withheld critical information showing that the shaft would not work in wet soil conditions", EuroChem said in a statement on 13 October. The panel awarded EuroChem-VolgaKaly \$112 million in damages and \$8 million in legal costs as part of the settlement.

EuroChem said it believed the decision showed that Shaft Sinters acted "to win and retain a contract to build a mine shaft with a method that it knew was likely to fail, while purposefully and deliberately withholding information that confirmed the likely failure".

## KAZAKHSTAN

## EuroChem receives first Kazakh phosphate shipment

EuroChem has received the first consignment of ground phosphate rock from its new \$160 million mine in Kazakhstan. Around 11,000 tonnes of phosphate rock (av. grade 30.5%  $P_2O_5$ ) was delivered to its subsidiary EuroChem-Belorechenskies Minudobrenia (BMU) in October.

"With this first intra-group shipment, EuroChem moves closer to being self-sufficient in the production of phosphate rock," Dmitry Strezhev, EuroChem's CEO, said.

"Additionally, we plan to further strengthen our presence in Kazakhstan with the construction of a fertiliser complex in close proximity to our mining facilities."

BMU is located in the southwest of Russia and concentrates on MAP and NP fertiliser production. EuroChem is expecting an additional 41,000 tonnes of ground phosphate deliveries to its plants in Russia and Belgium by the year's end.

## PAKISTAN

## Pakistan introduces DAP, NP and NPK subsidy

The Pakistan government formally enacted a PKR 20 billion (\$191 million) package of DAP, NP and NPK fertilizer subsidies for the country's farmers in mid-October. Implementation of the subsidy, announced in the 2015/16 budget and due to commence at the start of October, was delayed by around a fortnight.

The subsidy has been set at PKR 500 on a 50 kg bag of DAP and PKR 217 on 50 kg bag of NP/NPK fertilizer, the Ministry of National Food Security and Research has confirmed.

The subsidy will be paid to manufacturers and importers within 15 working days on receipt of a sales tax invoice, the government said. Payments will continue until the full PKR 20 billion budget has run out.

The State Bank of Pakistan has set aside PKR 10 billion to distribute the subsidy to Pakistan's DAP manufacturers. The remaining 50% of the subsidy will be placed in the hands of the Punjab and Sindh provincial governments.

## EGYPT

## Red Sea phosphate complex approved

Egypt's President Abdel Fattah El-Sisi has personally approved the construction of a large-scale fertilizers complex at Ain Sokhna on Egypt's Red Sea coast, according to an Egyptian government statement.

The state-controlled El Nasr Co for Intermediate Chemicals is planning to produce a range of phosphate products at the site for the domestic and export markets. The complex, which also includes a phosphoric acid and sulphuric acid plant, will have the capacity to produce 400,000 t/a of DAP, 250,000 t/a of TSP and 100,000 t/a of powdered MAP/DAP.

Construction of the complex is expected to take four years and will be built using Spanish, Italian and Chinese technology. ■

## CONTENTS

What's in issue 469

## COVER FEATURE 1

Citrus fertilisation

## COVER FEATURE 2

Pakistan's fertilizer industry

## COVER FEATURE 3

Phosphorus recovery finally breaks through

FERTILIZER INTERNATIONAL  
ISSUE 469  
NOVEMBER-DECEMBER 2015

BCInsight

Southbank House, Black Prince Road  
London SE1 7SJ, England

Tel: +44 (0)20 7793 2567

Fax: +44 (0)20 7793 2577

Web: www.bcinsight.com  
www.bcinsightsearch.com

# People

## Uralkali reorganises sales and marketing

**Vladislav Lyan** took over as head of Uralkali's overseas sales at the start of November. His appointment follows the resignation of Oleg Petrov, the firm's previous sales and marketing director, on the 15 October.

Dmitry Osipov, Uralkali's CEO, said: "We welcome Vladislav as a valuable member of our team and we believe he has the necessary leadership and skills to maintain and expand Uralkali's leading position in the global potash market."

Uralkali subsequently announced on the 22 October that it was dissolving its existing sales and marketing department and had appointed Alexey Strakhov to the role of domestic market sales director, effective from the start of November. Strakhov leads a newly-established domestic market sales department and will report directly to Uralkali's CEO.

## Saudi Aramco confirms new CEO

Saudi Aramco has officially appointed **Amin Nasser** as its president and CEO.

Nasser has held both roles on an acting basis since May, following a ministerial reshuffle by King Salman bin Abdulaziz on his ascension to the kingdom's throne. Nasser was previously Aramco's senior vice president for upstream operations.



Amin Nasser.

He replaces Khalid al-Falih, Aramco's current chairman and Saudi Arabia's health minister.

Confirmation of the appointment emerged during the first meeting of the Saudi Aramco Supreme Council, the governing body created earlier this year as a replacement for the Supreme Petroleum Council abolished by King Salman.

## Sandvik appoints new CEO

**Björn Rosengren** succeeded Olof Faxander as president and CEO of Sandvik at the

start of November. He was previously president and CEO of Wärsilä Corporation.

His predecessor, Olof Faxander, who left the company in August at the behest of Sandvik's board, had been president and CEO since 2011.

"I know Björn Rosengren as an exceptionally experienced and successful industrial leader. He has the experience needed to develop Sandvik into the future", said Sandvik's chairman Johan Molin.

Sandvik's executive vice president and CFO, Mats Backman, was appointed acting president and CEO for three months in August, pending Rosengren's arrival at the company.

## Changes to Outotec's executive board

**Jari Älgars** joined Outotec as chief financial officer (CFO) at the start of October. Trained as an economist, Älgars previously occupied a number of high-level leadership and financial positions at Andritz. The current CFO, Mikko Puolakka, will continue working for Outotec until the end of January next year to ensure a smooth transition.

Another executive board member, Minna Aila, senior vice president for marketing, communications and corporate responsibility, left Outotec in mid-October. Other board member have assumed her responsibilities pending the recruitment of a replacement. ■

# Calendar 2016

## JANUARY

27-29

Fertilizer Latino Americano 2016, CARTAGENA, Colombia  
Contact: CRU Events  
Chancery House, 53-64 Chancery Lane, London WC2A 1QS, UK  
Tel: +44 20 7903 2444  
Email: conferences@crugroup.com  
Web: www.crugroup.com

## FEBRUARY

2-4

22nd AFA Annual International Fertilizer Forum & Exhibition, CAIRO, Egypt  
Contact: AFA Conference Section  
Tel: +20 2 2417 2347  
Email: info@afa.com.eg  
Web: www.afa.com

## MARCH

13-15

Phosphates 2016, PARIS, France  
Contact: CRU Events  
Chancery House, 53-64 Chancery Lane, London WC2A 1QS, UK  
Tel: +44 20 7903 2444  
Email: conferences@crugroup.com  
Web: www.crugroup.com

## APRIL

11-13

TSI World Sulphur Symposium, VANCOUVER, Canada  
Contact: AFA Conference Section  
Tel: +1 202 331 9660  
Email: sulphur@sulphurinstitute.org  
Web: www.tsi.org

## MAY

30 - June 1

84th IFA Annual Conference, MOSCOW, Russia  
Contact: IFA Conference Service, 28 rue Marbeuf, 75008 Paris, France  
Tel: +33 1 53 93 05 00  
Email: ifa@fertilizer.org

## JUNE

23-24

International Fertilizer Society Meeting, BUDAPEST, Hungary  
Contact: International Fertilizer Society, PO Box 12220, Colchester, CO1 9PR, UK  
Tel: +44 1206 851819  
Email: secretary@fertiliser-society.org

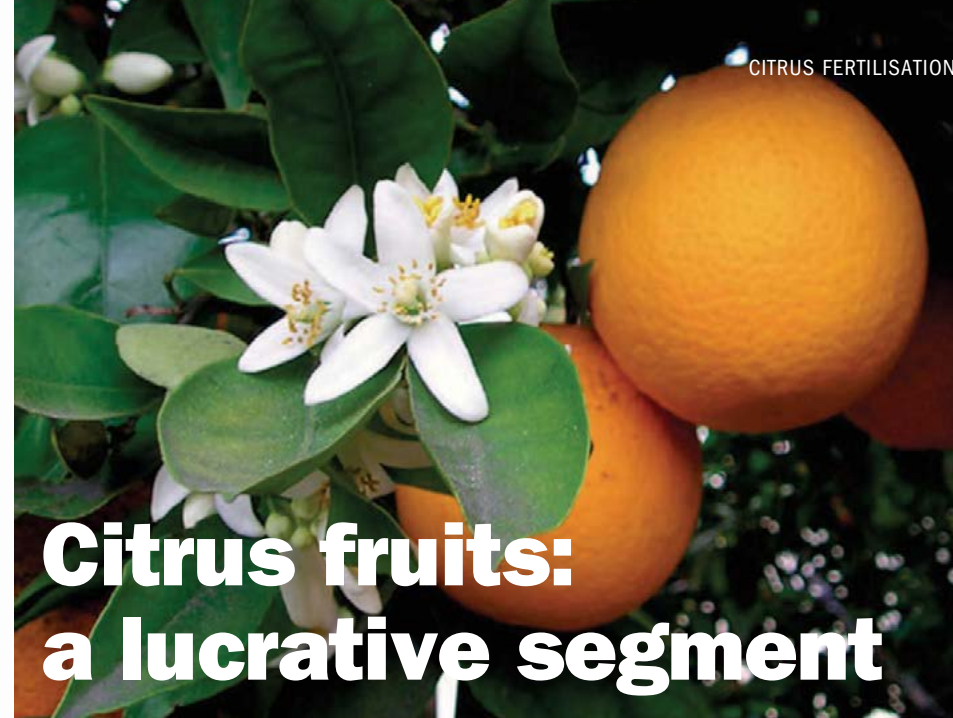

PHOTO: ELLEN LEVY

A combination of factors makes citrus fruit an attractive market for fertilizer suppliers, particularly the high K and N requirement of this widely-cultivated cash crop and the efficacy of fertigation and foliar products. We examine the nutrient needs of citrus trees and how balanced application of fertilizers helps maximise citrus fruit quality and yield.

Citrus fruits are a major cash crop, worth \$3.4 billion in the US alone, and around 7.4 million hectares (18.4 million acres) of land is devoted to their cultivation globally (Figure 1). World production has undergone a major expansion and almost doubled over the last 30 years, increasing from around 58 million t/a in the 1980s to more than 110 million t/a at the start of the current decade<sup>1</sup>.

Oranges remain the most popular type of citrus fruit, accounting for almost six tenths of world citrus production, and are widely grown in Brazil, China, the US, Mexico and the Mediterranean. China is the leading global grower of grapefruit and easy-to-peel citrus varieties, such as tangerines, mandarins, clementines and satsumas, and has an impressive third share of the world citrus market. Over half of the world's lemon and limes currently come from Mexico and the Mediterranean countries of the EU (Figure 2).

Although the size of the global citrus fruit market has stagnated over the last five years, a 7-8 million t/a decline in orange

Fig 1: Growing area, yield and production for citrus fruits, 2012

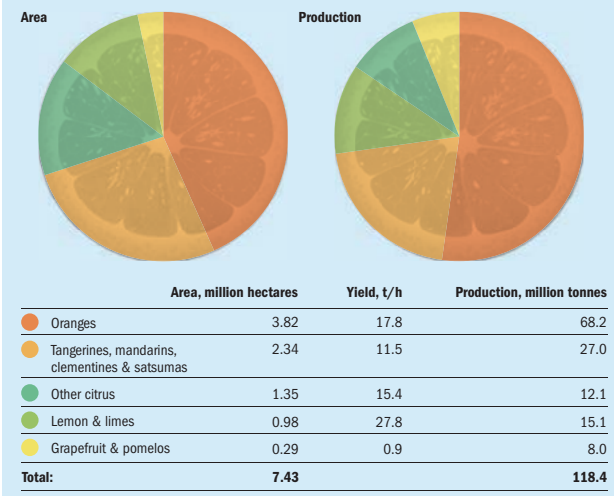

## CONTENTS

What's in issue 469

## COVER FEATURE 1

Citrus fertilisation

## COVER FEATURE 2

Pakistan's fertilizer industry

## COVER FEATURE 3

Phosphorus recovery finally breaks through

FERTILIZER INTERNATIONAL  
ISSUE 469  
NOVEMBER-DECEMBER 2015

BCInsight

Southbank House, Black Prince Road  
London SE1 7SJ, England

Tel: +44 (0)20 7793 2567

Fax: +44 (0)20 7793 2577

Web: www.bcinsight.com  
www.bcinsightsearch.com

Fig 2: World production of citrus fruits for selected countries, 2013/14 ('000 tonnes)

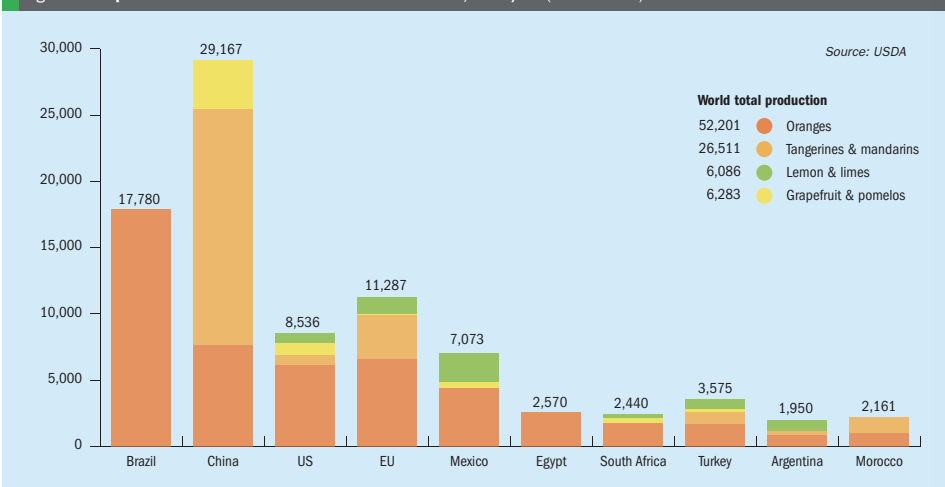

production has been almost offset by steadily growing tangerine/mandarin production which is set to reach a record-breaking 27 million tonnes this year<sup>2</sup> (Table 1). Production in Florida, which is responsible for two third of US production, has fallen from over 8 million tonnes in 2011/12 to less than 6 million tonnes in 2014/15 due to drops in yields resulting from 'citrus greening' disease afflicting the state's groves.

According to USDA figures, around three-fifths of world orange production in 2013/14 (52.2 million tonnes) was consumed as fresh fruit (30.1 million tonnes) and the remaining two-fifths (21.5 million tonnes) went for processing, yielding 2.1 million tonnes of orange juice. Close to 4 million tonnes of fresh fruit and 1.6 million tonnes of fruit juice was exported from the major producing countries last year.

### Varieties, climate and soil

The genus *Citrus* is a type of evergreen tree native to tropical and subtropical Asia. Belonging to the family *Rutaceae*, it numbers around 1,500 species, the main commercial, fruit-producing varieties being:

- Orange (*Citrus sinensis* [L.] Osbeck)
- Mandarin (*Citrus reticulata* Blanco)
- Lemon (*Citrus limon* [L.] Burm.)
- Lime (*Citrus aurantifolia* [Christ.] Swing.)
- Grapefruit (*Citrus paradisi* Macf.)
- Pomelo (*Citrus grandis* [L.] Osbeck)

Table 1: World citrus production, 2010/11 to 2014/15

Year	Total citrus	Oranges	Tangerines/mandarins	Grapefruit	Lemons & limes
2010/11	90,179	55,942	21,978	5,227	7,032
2011/12	89,903	53,830	23,908	5,544	6,521
2012/13	87,049	50,016	24,683	5,842	6,508
2013/14	91,081	52,201	26,511	6,086	6,283
2014/15*	88,473	48,382	27,119	6,054	6,918

\*Forecast

Table 2: Major nutrient and micronutrient removal by citrus fruits

	Major nutrient removal, kilogram per tonne of fresh fruit				
	N (kg/t)	P <sub>2</sub> O <sub>5</sub> (kg/t)	K <sub>2</sub> O (kg/t)	MgO (kg/t)	CaO (kg/t)
Oranges	1.773	0.506	3.194	0.367	1.009
Tangerines	1.532	0.376	2.465	0.184	0.706
Lemon & Limes	1.638	0.366	2.086	0.209	0.658
Grapefruit	1.058	0.298	2.422	0.183	0.573

	Micronutrient removal, gram per tonne of fresh fruit				
	Fe (g/t)	Mn (g/t)	Zn (g/t)	Cu (g/t)	B (g/t)
Oranges	3.0	0.8	1.4	0.6	2.8
Tangerines	2.6	0.4	0.8	0.6	1.3
Lemon & Limes	2.1	0.4	0.7	0.3	0.5
Grapefruit	3.0	0.4	0.7	0.5	1.6

Source: University of Florida Citrus Research and Education Center, Halfa, 2014

Table 3: Nutrient effects at different citrus growth stages

Nutrient	Flowering	Fruit set	Fruit enlargement and maturation	Post harvest
N	Boost yield and tree productivity	Maintain leaf growth, flowering and strong fruit set	Maintain yields and improve skin thickness and fruit acidity	Encourage active flush of foliage
K	Establish good early growth	Continued strong growth	Maximize fruit fill and fruit size, productivity, skin quality and vitamin C content and reduce granulation and fruit splitting	Maintain long-term fruit productivity
P	Maintain long-term productivity			Maintain long-term tree productivity
Ca	To aid leaf growth, pollination and fruit set	Provide good fruit productivity and quality	Boost leaf growth and tree vigour and reduce skin disorders, including fruit splitting and albedo breakdown	To maintain tree root health and productivity and to encourage leaf flush
Mg		Continued strong growth	Maintain fruit fill, fruit size and condition	
Micro-nutrients		Zinc, manganese and iron to maintain fruit yield and quality; boron to minimize fruit drop, prevent fruit deformities or storage problems from peel breakdown	Zinc to maintain fruit quality; molybdenum to improve juice content, quality and provide a thicker skin; copper to prevent fruit corking; manganese and boron to maintain fruit yield	Iron, manganese and zinc, when needed, for post-harvest foliage flush

Source: Yara

Citrus trees are geographically confined to an equatorial zone between the latitudes of 40°N and 40°S due to their cold-sensitivity and intolerance of frost. In practice, major citrus growing regions are generally to be found in two bands between 25° and 35° either side of the equator.

Citrus growing in semi-tropical and Mediterranean climates is most favourable as it results in smooth skinned, bright coloured fruit with an ideal balance of sweetness and acidity. Sweet oranges and mandarins thrive in sub-tropical regions, where the hot humid summers and mild winters yield

large, good quality, sweet fruits with a high juice content, making them ideal for either processing or fresh consumption. Navel oranges, blood oranges and lemons, in contrast, are almost exclusively grown in Mediterranean-type climates.

Citrus trees prefer well-drained, low salinity soils with a pH of 5.5-7.0. Although they can be grown on a range of soil types, from sands to clay loams, a well-structured soil ensures root aeration and helps avoid root disease. Acid soil conditions are avoided as citrus yields almost half when pH drops to 4.5.

Citrus trees develop shallow, near-surface root systems in the area under the tree canopy, and require careful water management to avoid root damage. Irrigation is common in many citrus growing areas outside the tropics as higher fruit yields are typically obtained from irrigated groves compared to those in rain-fed areas.

### Nutrients and quality

Nutrient and water availability both have a major influence on citrus fruit quality and yield. Fruit size, colour, juice content, sugar

CONTENTS

What's in issue 469

COVER FEATURE 1

Citrus fertilisation

COVER FEATURE 2

Pakistan's fertilizer industry

COVER FEATURE 3

Phosphorus recovery finally breaks through

FERTILIZER INTERNATIONAL  
**ISSUE 469**  
 NOVEMBER-DECEMBER 2015

**BCInsight**

Southbank House, Black Prince Road  
 London SE1 7SJ, England  
 Tel: +44 (0)20 7793 2567  
 Fax: +44 (0)20 7793 2577  
 Web: www.bcinsight.com  
 www.bcinsightsearch.com



Table 4: Nutrient status of citrus trees based on leaf analysis

Major nutrients, %	Nutrient status*				
	Deficient	Low	Optimum	High	Excess
N	<2.2	2.2-2.4	2.5-2.7	2.8-3.0	>3.0
P	<0.09	0.09-0.11	0.12-0.16	0.17-0.30	>0.30
K	<0.7	0.7-1.1	1.2-1.7	1.8-2.4	>2.4
Ca	<1.5	1.5-2.9	3.0-4.9	5.0-7.0	>7.0
Mg	<0.20	0.20-0.29	0.40-0.49	0.50-0.70	>0.70
S	<0.14	0.14-0.19	0.20-0.39	0.40-0.60	>0.60
Cl	-	-	0.05-0.10	0.11-0.25	>0.25
Na	-	-	-	0.15-0.25	>0.25
Micronutrients, ppm	Deficient	Low	Optimum	High	Excess
Mn	<17	18-24	25-100	101-300	>300
Zn	<17	18-24	25-100	101-300	>300
Cu	<3	2-4	5-16	17-20	>20
Fe	<35	35-59	60-120	121-200	>200
B	<20	20-35	36-100	101-200	>200
Mo	<0.05	0.06-0.09	0.1-1	2-5	>5

\*Based on samples of undamaged 4-6 month old spring leaves

Source: University of Florida Citrus Research and Education Center, Halifa, 2014

content (expressed as total soluble solids, TSS) and acid concentration are some of the most important quality factors for citrus growers, processors and packers. Qualities required for the fresh fruit and processing markets are distinctly different. Size, shape, colour and maturity date are important in fresh fruit, whereas high juice and soluble solids content are the main quality factors in fruit processing. Importantly, the external characteristics favoured in fresh citrus produce, such as fruit size and rind coarseness, are normally obtained with lower N and higher K applications than are necessary for fruits grown for processing.

Potassium followed by nitrogen and then calcium are the nutrients removed in greatest quantity by citrus trees (Table 2). The high level of potassium removal is linked to the high K content of citrus juice. Citrus tree are able to store significant amounts of nutrients in their roots and trunk and later redistribute these to developing leaves and fruits. The nutrient requirements of citrus trees also vary greatly at different growth stages (Table 3).

Leaf analysis is used to monitor the nutrient status of citrus trees, identify deficiencies and tailor fertiliser rates to ensure the correct ratio of plant nutrients (Table 4). This is supplemented by soil analysis of pH and N, P, K, Ca and Mg.

### Nitrogen for juice and colour

Nitrogen is critically important in citrus production as it has more influence on tree growth, appearance, fruit production, and fruit quality than any other nutrient<sup>3</sup>. Fruit yield is largely regulated by N due to its contribution to photosynthesis, carbohydrate production, leaf weight and carbon allocation within trees.

Mature trees require N at around 100-300 kg/ha, depending on environmental factors, the irrigation system and target yield. A fruit yield of 40 t/ha, for example, removes about 50 kg of N from soil. Although fruit yields generally correlate with N application, 200 kg/ha applied annually is thought to be sufficient to sustain good yields and tree development. In fertigation, however, yields continue to increase at N applications of up to 300 kg/ha<sup>4</sup>.

'Luxury consumption' from excess N can reduce the commercial value of harvested fruits by affecting fruit quality and shortening storage life. The fruit becomes large and puffy, skin thickens and coarsens, and the percentage and quality of juice also declines<sup>5</sup>. These adverse effects become exacerbated when P is low.

Visible signs of nitrogen deficiency are rare but citrus trees will show symptoms

– leaves turning light green to yellow and dropping early is one sign – when leaf N content falls below 2%. However, large falls in N over a prolonged period can occur before citrus yields are affected. This is because citrus trees have the capacity to adjust to inadequate nitrogen application by recycling stores of N, usually from older leaves into newer ones.

Increasing N application results in the following changes to fruit yield and quality<sup>6</sup>:

- Higher juice content, total soluble solids (TSS), acid concentration and improved colour
- Increases in TSS per hectare, although excessive N reverses this trend, particularly with inadequate irrigation
- Decreases in fruit size and weight
- Increases in peel thickness and numbers of green fruit at harvest
- Increasing incidence of creasing and scab but decreasing incidence of peel blemishes

### Potassium for size

The significant amounts of potassium removed by citrus fruit make the application of K fertilizers essential for maintaining soil productivity. The production of one tonne of oranges, for example, takes up

around 2.5 kg of K<sub>2</sub>O, corresponding to a soil removal rate of 125-250 kg/ha.

In Florida, Brazil and Australia, potassium application has been found to increase fruit production until leaf K content reaches 1.5-1.7%. Insufficient K typically produces small fruit with thin rinds which are prone to creasing or splitting, making them unsuitable for the fresh fruit market and export. Excessive levels of K produce large fruits with coarse, thick rind and poor colour. Potassium improves the external characteristics of citrus fruit but can reduce juice yield and quality. Higher applications of K are associated with:

- Larger fruit size, weight, green fruit and peel thickness
- Reduced incidence of creasing and fruit plugging
- Less stem-end rot in stored fruit
- Higher fruit production and TSS per hectare
- Reduced juice content and juice colour
- Increased acidity

The effectiveness of K applications varies widely with soil type. Potassium uptake by citrus trees is highest in acid, sandy soils in humid regions such as Florida.

### Phosphorus for growth

Phosphorus application is particularly important for early tree growth in new groves and maintaining fruit yield and quality in mature groves. However, application rates are relatively low, with the exception of South Africa and parts of Florida, as citrus trees have a limited P requirement compared to N and K<sup>4</sup>. The production of one tonne of citrus fruit only requires 0.2 kg of P, for example, and a fruit yield of 40 t/ha removes just 8 kg of P per hectare.

In P deficient trees, leaves become a dull bronze-green colour and are shed from young shoots, and tree growth and fruiting are also reduced. Low P produces misshapen fruit with coarse, thick rinds and acid juice. Ensuring a balanced supply of nitrogen and phosphorus is important as excess N can exacerbate P deficiency. The application of P is associated with the following changes to fruit quality:

- No change or a slight decrease in fruit size
- A decrease in rind thickness
- No change or slight increase in TSS
- Reduction in juice acidity
- Lower juice vitamin C content

### Lowering acidity, improving soil quality

Citrus trees contain more calcium than any other metal and calcium plays a vital role in regulating the uptake of other nutrients such as potassium and magnesium. Under normal growing conditions, however, soil calcium levels and general fertilisation practice are usually enough to satisfy citrus cultivation requirements<sup>4</sup>. Irrigation water can also supply calcium in appreciable amounts.

As well as its role as a nutrient, adding calcium can improve the physical properties of heavy soils and reduce soil acidity. Citrus trees are particularly sensitive to acidity and stop growing below pH 5.0 due to root system damage. Dressings of dolomitic or calcareous limestone to correct pH are known to increase yields by up to 200%<sup>4</sup>.

Magnesium, a constituent of chlorophyll, is found in the leaves and shoots of citrus trees and deficiency is very common on highly acid, low-magnesium soils. This results in leaf chlorosis and bronzing in older leaves.



## Ludman Industries

### Worldwide Leader in Fertilizer Compaction

A new generation of LARGE ROLL COMPACTORS

Latest Technology • Higher Throughput Capacity  
Rugged Design • High Reliability • Superior Performance.

- Over 50 years experience in building roll compactors for Potash, Amsul, Potassium Sulphate, NPK...
- Over 120 compactors operating in fertilizer plants worldwide.
- 32 compactors ordered for potash alone in the last 3 years!



**Ludman Industries USA**  
Forging Innovation, Building Quality.  
4810 N. 124th Street, Milwaukee, WI 53225  
Phone 414-431-3500 • Fax 414-431-1850  
E-mail: sales@ludman.net  
[www.ludman.net](http://www.ludman.net)

## Fertilizer recommendations

Fertilizer recommendations for young trees vary with soil type, climate and intensity of cultivation. The N, P and K applications rates for establishing trees on loamy, organic-rich Brazilian soils, for example, are lower than those for sandy, low organic matter Floridian soils (Table 5). Recommendations in the two countries also vary because Brazilian groves are also mostly unirrigated and begin producing in year three, whereas citrus fruits in Florida are more intensively grown and groves are irrigated because of the low water retention soils.

Fertilizer rates during the first three years in citrus groves are calculated on a per tree basis. A minimum of 4-6 annual applications of dry fertilizer is recommended for young trees, whereas yearly fertigation applications of 10 or more are usual at this stage.

Citrus trees are commonly harvested for fruit from year four onwards. N and K are key nutrients at this stage whilst P is less critical because of the much smaller quantities removed by fruit. Mature trees are therefore generally fertilized at a N:P<sub>2</sub>O<sub>5</sub>:K<sub>2</sub>O ratio of about 1.0:0.2:1.0. Around 3-6 kg of nitrogen is required to produce a single tonne of fruit and N applications rates are often used as the basis of recommendations for other nutrients.

In Florida, N is applied to oranges at a rate of 135-225 kg/ha (120-200 lbs/acre) in years 4-7 and then at 160-280 kg/ha (140-250 lbs/acre) from year eight onwards. These amounts of N are supplied

Table 5: Fertilisation of young trees in Florida and Brazil

Year	N (g/t/year)	P <sub>2</sub> O <sub>5</sub> (g/t/year)	K <sub>2</sub> O (g/t/year)	MgO (g/t/year)
<b>Brazil</b>				
1	100	0	20	-
2	160	160	80	-
3	240	240	160	-
4	360	320	320	-
<b>Florida</b>				
1	200	200	200	65
2	330	330	330	110
3	440	440	440	150
4	500	500	500	165

Source: University of Florida Citrus Research and Education Center

by at least one application for controlled-release fertilizers, by 3-6 separate applications in field dressings and 10 fertigation applications each year. The generally accepted rule for citrus K application is to follow exactly the same application rate as N for both young and mature trees. Identical N and K application rates, for example, are recommended by Haifa in its citrus guide<sup>7</sup> (Table 6).

Phosphorus application rates are determined on the basis of leaf analysis and soil testing results. Application of P is generally only recommended when soil P is less than sufficient and leaf P is at risk of falling below the optimum level (Table 7).

Magnesium fertilizers are applied, either to soil or in a foliar spray, at 20% of the N application rate, but only if leaf Mg is below optimum and soil tests show medium or low Mg levels. Liming the soil to regulate pH at 6.0-6.5 usually supplies sufficient Ca. If soil pH is maintained, there is no need to apply gypsum or soluble calcium fertilizers unless soil tests and leaf analysis show levels are insufficient and below optimum.

Micronutrients are applied by foliar spraying or directly to soil in response to low leaf analyses or visible signs of leaf deficiency. Foliar applications of Mn, Zn, Cu, B and Mo are generally much more

Table 6: Nitrogen and potassium recommendations for citrus

	N rate (g/tree/year)	Equivalent KNO <sub>3</sub> * rate (g/tree/year)	K rate (g/tree/year)	Equivalent KNO <sub>3</sub> * rate (g/tree/year)
<b>Young trees</b>				
Year 1	70-140	500-1,000	70-140	150-300
Year 2	140-280	1,000-2,000	140-280	300-600
Year 3	280-420	2,000-3,200	280-420	600-900
<b>Trees, 4-7 years</b>				
Grapefruit	120-160	900-1,200	120-160	260-350
Orange, tangelo or tangerine	120-200	900-1,500	120-200	260-430
<b>Trees, 8 years and older</b>				
Oranges	140-250	1,000-1,900	140-250	300-540
Grapefruit	120-160	900-1,200	120-160	260-350
Tangerine/Tangelo	120-300	900-2,300	120-300	260-650

\*Haifa's Multi-K product

Source: Haifa

Table 7: Phosphorus recommendations based on leaf analysis and soils testing

P level from leaf analysis*	Soil P level from testing	P recommendation
High or very high	No need to test	No application necessary, retest in 12 months.
Optimum	Sufficient	No application necessary, retest in 12 months.
Optimum	Less than sufficient	8 Kg P <sub>2</sub> O <sub>5</sub> /ha for every 9,500 kg of fruit produced per ha during one year.
Low	Less than sufficient	12 Kg P <sub>2</sub> O <sub>5</sub> /ha for every 9,500 kg of fruit produced per ha during one year.
Deficient	Less than sufficient	16 Kg P <sub>2</sub> O <sub>5</sub> /ha for every 9,500 kg of fruit produced per ha during one year.

\* See Table 4

Source: Haifa, Obreza & Morgan, 2011

effective and economically practical than soil applications. Foliar spraying usually takes place after full leaf expansion of new growth. Copper should not be applied separately if Cu fungicides are used. Molybdenum deficiency occurs in very acid soils and is a potential indicator of aluminium toxicity. Iron deficiency can be corrected using an Fe chelate.

## Cash crop opportunities

The status of citrus fruit as a profitable cash crop makes it a lucrative target market for leading fertilizer suppliers. Numerous bespoke and speciality products are now available for citrus growers, backed by detailed recommendations and extensive agronomic research. Although not exhaustive, a snapshot of currently-available citrus fertilizer products is provided below.

Haifa Chemicals' Multi-K potassium nitrate and Tensenderlo Chemie's SoluPotasse potassium sulphate products provide citrus growers with chloride-free source of

major nutrients and are suitable for both fertigation and foliar application. Ferti-K, a potassium chloride product supplied by the Dead Sea Works division of ICL Speciality Chemicals, is also used extensively in citrus fertigation. Following successful trials, foliar spraying of ICL's Nutrivant Booster, a trace element-enriched (13-0-46) speciality fertilizer, now forms part of Israeli ministry of agriculture recommendations for the country's citrus growers. Many of the formulations in SQM's field-applied (QDrop), fertigation (Ultrasoil) and foliar (Speedfol) product ranges are well-suited to the nutrient needs of citrus trees.

Phosphate products for citrus fertigation include SQM's UltrasoilMAP, Haifa's Multi-MAP and ICL's NovaMAP. Citrus micronutrient deficiencies can be addressed using Yara International's Yara-Vita range, for Mn, Zn and B deficiency, and SQM's Ultrasmicro iron chelate products for Fe deficiency. Both Yara (YaraLiva Tropicote) and SQM (QDrop Calcium) also market a straight application CAN fertilizer for citrus groves.

## References

1. FAO, 2012. *Citrus Fruit, Fresh And Processed, Annual Statistics 2012*. United Nations Food and Agriculture Organisation, Rome.
2. USDA, 2015. *Citrus: World Markets and Trade*. United States. Department of Agriculture Foreign Agricultural Service, July 2015
3. Obreza, T. & Morgan, K., 2011. *Nutrition of Florida Citrus Trees, Second Edition*. University of Florida IFAS Extension.
4. Emer, Y. et al., 1999. *Fertilizing for High Yield Citrus*. IPI Bulletin No 4, 2nd Revised Edition. International Potash Institute (IPI), Switzerland.
5. NSW, 2002. *Citrus Nutrition*. Agfact Series H2.3.11, Second edition. NSW Department of Primary Industries.
6. Zekri, M. et al., 2003. *Irrigation, Nutrition, and Citrus Fruit Quality*. Document SL 207. Revised 2009, reviewed 2015. University of Florida, Soil and Water Science Department.
7. Haifa, 2014. *Nutritional Recommendations for Citrus*. Haifa Chemicals Ltd.

## FREE WEBINARS AND PRESENTATION SLIDES:

Nitrogen | Phosphate | Potash | Sulphur

Integer Research are delighted to offer you free access to our market outlook webinars and presentation slides for nitrogen, phosphate, potash and sulphur markets.

integer  
insight  
beyond  
numbers

FREE ACCESS HERE: [www.integer-research.com/free2015](http://www.integer-research.com/free2015)

What's in issue 469

COVER FEATURE 1

Citrus fertilisation

COVER FEATURE 2

Pakistan's fertilizer industry

COVER FEATURE 3

Phosphorus recovery finally breaks through

FERTILIZER INTERNATIONAL  
ISSUE 469  
NOVEMBER-DECEMBER 2015

BCInsight

Southbank House, Black Prince Road  
London SE1 7SJ, England

Tel: +44 (0)20 7793 2567

Fax: +44 (0)20 7793 2577

Web: [www.bcinsight.com](http://www.bcinsight.com)  
[www.bcinsightsearch.com](http://www.bcinsightsearch.com)

# Ammonium sulphate heads from east to west

Since 2010, the global balance of ammonium sulphate production has shifted inexorably eastwards to China away from legacy producers in Europe, the US and the former Soviet Union. Large ammonium sulphate export volumes from China, a by-product of massive investment in caprolactam capacity, are reversing established trade flows. Despite this market shake up, the premium pricing of high-grade products continues to make ammonium sulphate supply an attractive proposition in some regions.

Ammonium sulphate (AS) fertilizer is a relatively low-volume, niche segment of the global nitrogen market. Its manufacture, around five million tonnes on a nitrogen basis, represents less than 4% of global nitrogen production. Such global statistics can be deceptive, however, as they underestimate the regional importance of ammonium sulphate as a relatively cheap source of nitrogen in North American, South American and South East Asian markets. In countries such as Mexico, for example, ammonium sulphate accounts for a fifth of nitrogen fertilizer consumption.

derived as a by-product, with large volumes arising as a consequence of so-called 'involuntary' production. Around three quarters of global AS supply comes from the manufacture of caprolactam (CPL), a petrochemical intermediate of nylon, and other involuntary sources. These include coke-oven gas (COG), coal emissions scrubbing, methyl methacrylate (MMA) manufacture and nickel pressure acid leaching (Ni-PAL). The 'voluntary' synthetic manufacture of AS, although less significant in volume terms (Figure 1), can produce a superior grade, higher-priced fertilizer product.

## Not all ammonium sulphate is created equal

The quality of ammonium sulphate varies greatly depending on its origin. Although standard grade material sourced from caprolactam predominates (Figure 1), sizeable premiums are available for higher grades such as the large white crystals demanded by more sophisticated agricultural markets. Ammonium sulphate products can generally be divided into five separate grades:

- **Low grade.** Sticky, brown, impure crystals derived from COG, MMA and gypsum.

Fig 1: Ammonium sulphate capacity by supply source and product grade

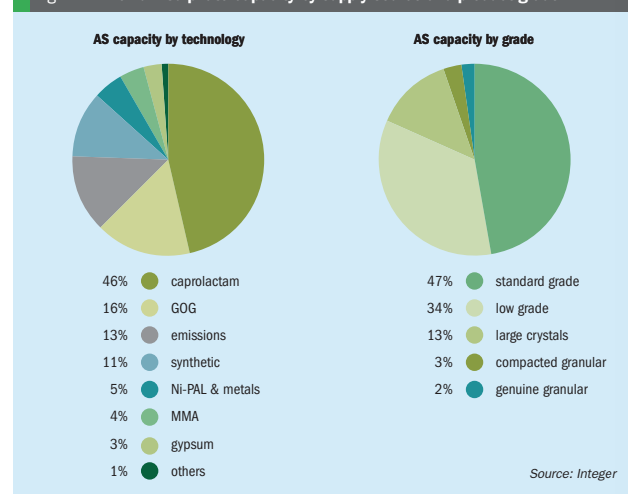

## Favourable demand trends

Furthermore, global demand for AS is expected to grow in response to land expansions in Brazil, and the rising cultivation of sulphur-intensive crops in the US, South East Asia and Oceania. The ability of AS to replenish the sulphur content of soils is also likely to make it increasingly valuable in North America and Europe, where air quality legislation is leading to falls in sulphur deposition. Some suppliers have also been able to profit from healthier margins by selling higher-grade ammonium sulphate at a premium price. Ammonium sulphate is also used in leather tanning, textile dyeing, cellulose and fiberglass insulation, fire extinguisher chemicals and fermentation. Overall global consumption is projected to increase at 2.3% annually this decade.

The market for ammonium sulphate tends to be supply driven because, unlike other nitrogen fertilizers, it is mostly

Fig 2: World ammonium sulphate production by region

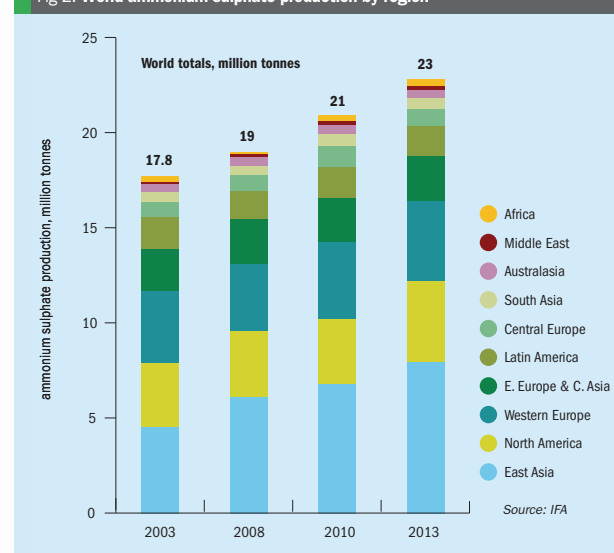

Fig 3: Rise of Chinese AS exports 2003-2013



Compacted material from these sources is also included as it is poor quality and likely to cake or crumble. Used in NPK compounds and direct applied in less-advanced agriculture.

- **Standard grade.** Small white or yellowish colour crystals with few or no impurities sourced from CPL, synthetic production, emissions scrubbing, Ni-PAL, acrylonitrile and cyanuric acid. Suitable for all applications.

- **Compacted.** Standard grade AS compressed by a compaction unit, which adds to costs but is less expensive than genuine granulation. Used for NPK blends and direct application.

- **Large crystals.** Crystals above 2 mm derived from CPL, synthetic production, Ni-PAL and COG. Slow drying adds to cost but less expensive than granulation. Used for NPK blends and direct application.

- **Genuine granular.** Round, robust AS granules above 2 mm in size from synthetic production which are resistant to crumbling. Most expensive grade due to the cost of granulation. Used for NPK blends and direct application.

Large AS crystals (2-3 mm) are valued by some farmers and can command a price premium compared to standard grade crystals (<1 mm). Ammonium sulphate premiums, which have also partly developed because of the greater price competition between standard grade suppliers, tend to be widest in the developed markets of Europe, North America, Australia and New Zealand. Lower premiums general apply in Asia, South East Asia and the Middle East, and are completely absent in the Former Soviet Union, India and China as large crystals are not available. In 2014, premiums for large crystals versus standard grade AS varied regionally as follows:

- North America and Japan, \$80-100/t
- Brazil, \$65-100/t
- Western Europe, \$45-85/t
- Mexico, \$30-50/t
- South East Asia, \$15-45/t

## Dramatic eastwards shift

Global consumption of ammonium sulphate has risen by around a third in the last ten years, reversing the declines seen during the preceding two decades<sup>1</sup>. Ammonium sulphate lost market share during the 1980s and 1990s due to a preference for higher nitrogen content fertilizers such as urea and ammonium nitrate.

Until relatively recently, ammonium sulphate has mainly come from long-standing caprolactam capacity in the advanced industrial economies of the US, Belgium, the Netherlands, Mexico, Japan and South Korea. These key global suppliers produced AS to meet their own domestic demand, but also relied on the important Asian export market. China, in particular, was a major ammonium sulphate importer prior to 2010. This meant that, up until five years ago, the ammonium sulphate market was governed by a prevailing west-to-east trade flow between the main centres of supply and the regions of demand.

However, the market has gone through a dramatic shift over the last decade following the emergence of China as the dominant global producer and exporter of AS. Traditional production powerhouses in North America, Central America and Europe have all seen their market share

What's in issue 469

COVER FEATURE 1

Citrus fertilisation

COVER FEATURE 2

Pakistan's fertilizer industry

COVER FEATURE 3

Phosphorus recovery finally breaks through

FERTILIZER INTERNATIONAL  
ISSUE 469  
NOVEMBER-DECEMBER 2015

BCInsight

Southbank House, Black Prince Road  
London SE1 7SJ, England

Tel: +44 (0)20 7793 2567

Fax: +44 (0)20 7793 2577

Web: www.bcinsight.com  
www.bcinsightsearch.com

Fig 4: Major AS consuming and importing countries 2013 ('000 tonnes)

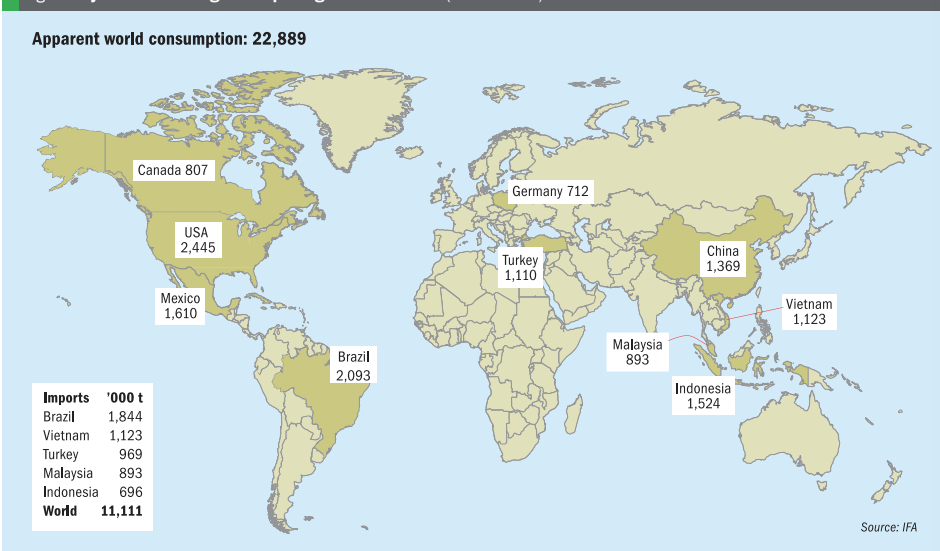

shrink in response to growing production in East Asia (Figure 2).

Chinese production underwent a three-fold increase between 2003 and 2013. The growth in Chinese output from 1.2 million t/a to 4.3 million t/a over this decade accounted for 60% of the expansion in global production. Chinese AS production has increasingly entered the international market having first reached and then surpassed the point of self sufficiency. Consequently, Chinese AS exports have inexorably grown from 109,000 tonnes in 2003 to 2.9 million tonnes in 2013 (Figure 3).

### Multiple producers, concentrated consumption

The major ammonium sulphate consuming countries are clustered in North and South America and South East Asia (Figure 4). The US, Canada, Mexico, China all have sufficient domestic AS capacity to meet most if not all of their internal demand, whereas Brazil, Vietnam, Turkey, Malaysia and Indonesia are major AS importers and reliant on external supply. The 3.4 million t/a South East Asian import market for AS is particularly important, commanding a 31% slice of total world trade, and is the main destination of Chinese exports.

World ammonium sulphate production largely comes from a group of ten Asian, North American, European and FSU countries (Figure 5). The leading exporting countries – China, Belgium, the US, Russia, South Korea and the Netherlands – collectively account for almost three quarters of global traded volumes. In terms of AS export destinations, Western European and North American suppliers mainly sell into the Latin American market, particularly Brazil, whereas FSU suppliers largely divide their exports between the Middle East and Latin America. East Asian suppliers have traditionally exported to the large South East Asian market.

China is, however, seeking new markets for its expanding export volumes, and increased overseas sales to Central America and Turkey last year. Symbolically, China has also supplanted Canada as the top US ammonium sulphate importer in the last 12 months. In the year to the end of June, China supplied 248,423 tonnes of the 458,662 tonnes of AS imported by the US, making it the country's single largest importer.

### Capacity additions

East Asia and North America have been the focus of global ammonium sulphate capacity additions over the last five years,

contributing 2.7 million t/a (57%) and 1.0 million t/a (20%), respectively, to the extra 4.8 million t/a of world AS capacity added between 2010 and 2015. China set itself the aim of becoming self sufficient in caprolactam capacity, to counter its high import requirements, resulting in a wave of extra Chinese AS output over the last half-decade.

As recently as 2010, Chinese AS capacity was largely emissions-based (59%) and topped up by minor caprolactam-derived capacity (13%) from just four plants. Since then, the concerted drive for caprolactam self-sufficiency saw Chinese AS capacity shoot up by more than two-fifths (43%) by 2014, according to analysts CRU.

Chinese AS output from its expanding caprolactam industry is continuing to outpace domestic demand, leading to more Chinese AS product entering the international market. Investment in more than 15 caprolactam expansion projects in China could bring 4.8 million tonnes of extra ammonium sulphate capacity on-stream between 2013 and 2016, according to some forecasts, increasing global capacity by around a fifth (Table 1). However, looking further ahead, IFA expects East Asian AS capacity to peak at 10.8 million tonnes this year with no further capacity additions in the four years beyond 2015<sup>2</sup>.

Fig 5: Major ammonium sulphate producing and exporting countries 2013 ('000 tonnes)

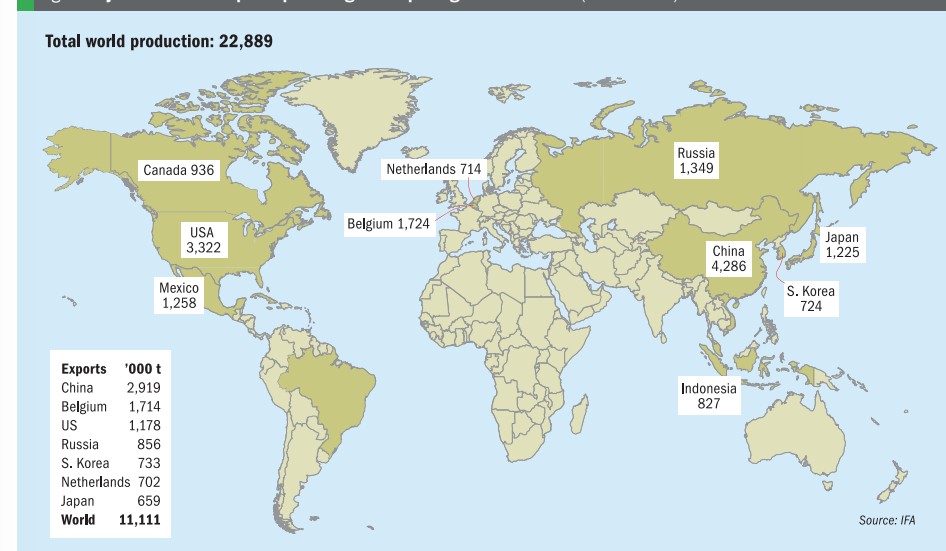

### Outside China

Unlike China, North America ammonium sulphate supply includes a number of large volume, synthetic producers as well as involuntary, caprolactam-based suppliers (Table 2).

Honeywell's caprolactam plant in Hopewell, Virginia is said to be the world's largest single AS fertilizer production site, supplying 1.5 million t/a annually. Ammonium sulphate from the plant is screened, sized and sold as a crop, pasture and horticultural fertilizer under the *Sulf-N* brand name. Honeywell also produces a *Sulf-N PRO* grade specifically for the professional turf and lawn care markets.

Rentech Nitrogen's acquisition of Agrifos' Pasadena, Texas plant for \$158 million in 2012 makes it the largest synthetic granulated ammonium sulphate producer in North America. The Pasadena plant is strategically located on the Houston Ship Channel allowing Rentech to target its sales at the domestic market and Brazil. Rentech sells ammonium sulphate as high-quality, premium-priced, dual-nutrient fertilizer suitable for corn, soybeans, wheat, canola and alfalfa.

Rentech increased the AS capacity of its Pasadena plant by 20%, from 1,750 t/d to 2,100 t/d, as part of a major debot-

tlenecking project in 2013. However, in response to falling revenues, Pasadena's AS production was subsequently cut by around quarter to 500,000 t/a at the end of last year in a bid to improve profitability and cut annual costs by \$10 million. In a revised sales strategy, 70% of this lower production volume will be sold domestically with the remainder targeted at New Zealand and Australia where AS can achieve a higher net price. Rentech's cut in production signalled the end of lower-margin AS sales to Brazil, although some peak season shipments may continue if these deliver higher returns. CVR Partners recently purchased Rentech Nitrogen for \$533 million (*Fertilizer International*, 468 p9), although this deal excludes the Pasadena AS plant, which is likely to be sold to a third party or retained by Rentech.

### Complex European deal-making

In Europe, caprolactam-derived AS capacity is mainly in the hands of EuroChem and CF Industries following a complex series of buy-outs, distribution deals and mergers.

BASF's Antwerp caprolactam plant in Belgium produces around 610,000 t/a of ammonium sulphate as a by-product. In spring 2012, EuroChem acquired BASF's Antwerp fertilizer production assets in a

\$1.1 billion deal, and later that year also bought K+S Nitrogen, the distributor for AS and the other fertilizers produced by BASF at Antwerp, for \$182 million.

However EuroChem later offloaded its distribution contract to OCI for the one million t/a of AS produced by Lanxess' Antwerp caprolactam plant in October 2012. The 800,000 t/a of crystalline and 200,000 t/a granular AS sourced from Lanxess added to OCI's existing distribution rights for the 700,000 t/a of ammonium sulphate produced by DSM at Geleen in the Netherlands. The supply of AS from DSM was secured through OCI's earlier purchase of DSM Agro in 2010. OCI's European operations are, however, due to be transferred to CF Industries as part of \$8 billion merger announced in August (*Fertilizer International*, 468 p9).

### Russia invests

Significant AS capacity expansions have been announced in Russia in the last 12 months. KuibyshevAzot recently formed a joint venture with Trammo to build a RUB 700 million (\$12.8 million) 140,000 t/a granular AS plant in Togliatti. Construction will begin this year and should be completed in 2017 (*Fertilizer International*, 467 p12). German company GEA Messo have

also signed a contract with PhosAgro to design and build a new 300,000 t/a crystalline AS production line at PhosAgro's Cherepovets site. PhosAgro will use the high-grade output from the new RUB 2.7 billion (\$400 million) plant to replace AS currently sourced from chemical and metallurgical plants. The new AS production line will consume ammonia and sulphuric acid produced on-site and is expected to be commissioned in 2017. PhosAgro is currently Russia's largest AS consumer due to the demand from NPK and NPKS blends.

### At the point of unprofitability

One consequence of the huge growth in Chinese caprolactam capacity has been to push ammonium sulphate onto the international market, eroding the market value of AS globally. For some producers, China's emergence as a major AS exporter has "pushed the market to a point of unprofitability", according to analysts CRU. In particular, market saturation in East and South East Asia is pushing Chinese supply into the Americas, pressuring prices in Brazil and Mexico. This has affected North American AS producers.

"The growth in Chinese caprolactam production has flooded the international market with new AS supply," comments CRU Senior Consultant, Peter Harrison. "The decision to cut annual production at Pasadena highlights the difficulties of being a synthetic producer of AS in a market dominated by by-product output."

To some extent, growth in Chinese AS production could moderate in future, partly because of the lower amounts of AS generated by modern caprolactam technology. Utilisation rates are also likely to fall as established caprolactam producers globally lose market share. Older technologies generate around 4.5 tonnes of AS for every tonne of caprolactam produced, whereas newer processes, such as DSM's HPO-plus technology, generate just 1.5 tonnes of AS by-product per tonne of caprolactam.

Looking ahead, analysts Integer Research still expect AS trade to increasingly move from east to west in future, reversing the previous prevailing flow of trade from the Black Sea to South East Asia.

"The future of the global AS market will be shaped by which markets Chinese product is sold into and in what quantities," explains Oliver Hatfield, Integer's fertilizers director. This in turn will depend on Chinese

Table 1: Caprolactam-based ammonium sulphate capacity expansion projects in China 2013-2016

Company	Location	AS capacity ('000 t/a)	Comment/completion time
Shandong Haili	Jiangsu	280	On-stream in August 2013
Hubei Sanning	Hubei	320	On-stream in August 2013
Luxi Chemical Group	Shandong	160	On-stream in June 2013
Fuzhou Yaolong Chemical	Fujian	320	2012-2014
Hebei Xuyang Chemical	Hefei	640	2014-2014
Dongju Chemical	Shandong	160	2012-2014
Juhua Group	Zhejiang	160	2012-2014
Shanxi Lanhua Kechuang	Shanxi	320	2012-2014
Inner Mongolia Qinghua	Inner Mongolia	320	2012-2014
Dongxin Oil & Chemical	Fujian	160	2012-2014
Shandong Huamao	Shandong	160	2012-2014
Sinopec Balin Petrochemical	Fujian	320	2013-2015
Sinopec Balin Petrochemical	Guandong	320	2013-2015
Yangquan Coal	Shanxi	320	2013-2015
Jiangsu Sanding Petrochemical	Jiangsu	160	2013-2015
Fujian Shenyan	Fujian	320	2013-2016
Pingnei Shenma	Henan	320	2013-2016

Source: Integer Outlook for ammonium sulphate study

Table 2: Leading North American AS producers

Company	Process	Production* ('000 t/a)
<b>Top five producers</b>		
Honeywell	Caprolactam	1,850
BASF	Caprolactam	725
Rentech Nitrogen	Synthetic	575
Agrium	Synthetic	385
DSM	Caprolactam	315
Total		3,850
<b>Other major synthetic producers</b>		
Simplot	Synthetic	215
Martin Midstream	Synthetic	140
GAC Chemical Corp	Synthetic	25

\*Approximate. Source: Rentech Nitrogen/Blue Johnson

AS quality and the extent to which AS is priced on its nitrogen and sulphur content.

"Premiums are key to understanding the market. We expect production of premium grades to increase, although demand will also increase as developing markets increasingly use mechanical application and blended fertilizers," concludes Hatfield. ■

### References

1. IFA, 2015. *AS Production Statistics*. IFA Production and International Trade.
2. IFA, 2014. *World Ammonium Sulphate Capacity 2014*. Capacities Summary Report, IFA Production and International Trade.

Uhde Fertilizer Technology, Stamicarbon, PROZAP and MECS have all introduced refinements to the scrubbing of dust and gas emissions from nitrogen plants in recent years. Some notable examples of the latest and most effective emissions reduction technologies are described.

The main environmental pollutants generated by modern urea plants are the dust and ammonia emissions from finishing sections, where the urea melt is solidified, typically by granulation or prilling, to obtain the final product.

The dust present in off-gases from urea granulation plants originates from a number of sources. The crushing of oversize granules, the evaporation/sublimation of urea melt, granule attrition and atomiser spray losses can all generate dust, for example<sup>1</sup>. Ammonia dissolved in the granulator's urea melt feed can also end up in exhaust gases. The synthesis section may leave trace amounts of ammonia in urea melt, and NH<sub>3</sub> can also arise from the hydrolysis of urea or as a result of biuret formation.

Scrubbing is necessary because the dust and ammonia emission in off-gases from urea prilling towers and granulators (Table 1) typically exceed international guidelines and the regulatory limits set by local authorities. Ammonia emissions from granulation stacks of 80-90 kg/h at a concentration of 100 mg/Nm<sup>3</sup> are not unusual<sup>2</sup>.

Long-standing guidelines from the World Bank's International Finance Corporation (IPC) and others specify that urea plant emissions should not exceed 50 mg/Nm<sup>3</sup> during normal operation. Subsequent emissions regulations have generally become much more stringent over time (Table 2).

New plants built in the US have to comply with particularly demanding emissions limits for particulate matter (PM) and stack plume visibility (Table 3). The development of advanced scrubbing sys-

# Finishing with emissions

Table 1: Average dust and ammonia emission levels in off-gases from urea plant prilling towers and granulators

Finishing method	Dust	Dust size (µm)	Ammonia (mg/Nm <sup>3</sup> )	Temp. (°C)
Prilling tower	80-220 mg/Nm <sup>3</sup>	1-2 (~45%)	60-180	60-85
Granulator	Up to 12 g/Nm <sup>3</sup>	1-1,000	90-180	100-110
Granulator cooler	Up to 4 g/Nm <sup>3</sup>	1-100	Trace	60-80
Ammonium nitrate prilling tower	80-160 mg/Nm <sup>3</sup>		40-120	

Source: PROZAP

Table 2: Examples of recommended and regulatory limits for dust and ammonia emissions from urea plants

Source	Urea dust/particulate matter (mg/Nm <sup>3</sup> )	Ammonia (mg/Nm <sup>3</sup> )
World Bank/IFC Pollution Prevention and Abatement Handbook (PPAH), 1998	<50	<50
European Fertilizer Manufacturers Association (EFMA) Best Available Technology (BAT) Booklet, 2001	<50	<50
EU Best Available Technology Reference Document (BREF), 2007	<15-55	<3-35
Saudi Arabia, Royal Commission Environmental Regulations (RCER), 2010	<0.25	<50
UAE, 2011	<30	<30
USA, 2013	<10	<15

Source: Stamicarbon

Table 3: US Environmental Protection Agency (EPA) emission limits for UFT projects

Project	Capacity (t/d)	Particulates (mg/Nm <sup>3</sup> )	Ammonia (mg/Nm <sup>3</sup> )	Plume visibility
CFI Donaldsonville, Louisiana	3,500	PM <sub>10</sub> <9 PM <sub>2.5</sub> <9 (<29.67 lb/h)	<32 (113.27 lb/h)	20% opacity
CFI Port Neal, Iowa	3,500	PM <sub>10</sub> <6 PM <sub>2.5</sub> <6 (<19.57 lb/h)	Acidic scrubbing required	No visible emissions
IFCo Wever, Iowa	1,200	PM <sub>10</sub> <0.1 kg/t PM <sub>2.5</sub> <0.025 kg/t (< 6 mg/Nm <sup>3</sup> )	Acidic scrubbing required	No visible emissions

Source: UFT

Table 4: Particle abatement technology options

Device	Size range (µm)	Removal efficiency (%)	Advantages	Disadvantages
Wet scrubbers (trays and spray towers)	1-2	70-80	Simultaneous removal of dust and inorganic compounds.	<ul style="list-style-type: none"> <li>● Relatively inefficient at removing fine particulates.</li> <li>● Relatively low mass transfer efficiency.</li> </ul>
	0.5	60		
	0.1	33		
Wet electrostatic precipitators	1-2	95-98	<ul style="list-style-type: none"> <li>● High efficiency even for small particulates.</li> <li>● Suitable for wide range of temperatures, pressures and gas flows.</li> <li>● Relatively small energy requirement due to low pressure drop.</li> </ul>	<ul style="list-style-type: none"> <li>● High voltage power needed.</li> <li>● Extra Capex for pre-filter.</li> </ul>
	0.5	91		
	0.1	95		
Fabric filters	1-2	99.7-99.8	<ul style="list-style-type: none"> <li>● High removal efficiency for all particle sizes.</li> <li>● Efficiency independent of intake concentration.</li> </ul>	Wet or sticky dust not permissible.
	0.5	99.1		
	0.1	99.8		
High-efficiency air cyclones	1-2	20-40	Simple, low cost.	Needs to be used in combination with another technology for smaller particle removal.
	0.5	8		
	0.1	-		

Source: Stamicarbon

Fig 1: Typical two-stage granulation plant scrubber

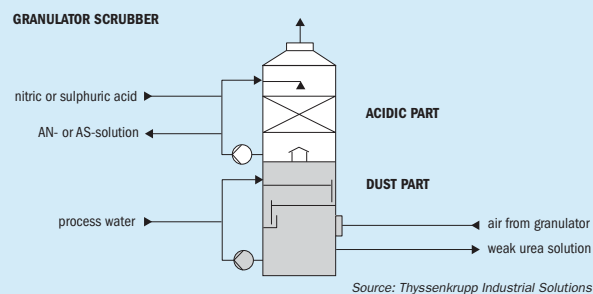

Source: Thyssenkrupp Industrial Solutions

tems with high separation efficiencies for submicron particles has been necessary to meet these increasingly stringent emissions standards. The enormous volumes of out-gases generated by the latest large-capacity urea plants have also made new approaches to emissions treatment a necessity.

Individual plant capacities have risen significantly in recent years to the extent that single line plants of 3,000-3,500 t/d have now become standard. QAFCO's two Unde Fertilizer Technology (UFT) designed plants in the Persian Gulf, for example, have nameplate capacities of 3,850 t/d – and are even able to operate beyond this with daily outputs of 4,200 t/d or more.

The main types of particle abatement technologies – wet electrostatic precipita-

tions, wet scrubbing, fabric-based filters and high efficiency cyclones – each have different strengths, weaknesses and size removal efficiencies (Table 4). Wet scrubbing technologies are most widely-applied in urea plants, although they vary considerably in terms of their design and the types of demister and moisturising/spraying systems employed.

### Wet scrubbing

Vertical scrubbers with multiple tray stages and/or mist eliminators are commonly used to capture and remove ammonia and urea dust particles from the exhaust gases of fluidised bed granulators and granulator coolers in the finishing section of urea plants. These gas scrubbers are designed to achieve extremely high removal

efficiencies, while at the same time keeping pressure drop low to minimise energy consumption. They function as follows:

- Recirculated urea solution enters at the top of the dust removal section and flows downwards by gravity
- The off-gas enters at the bottom of the scrubber and flows upwards in counter-current
- The urea solution flows horizontally over the trays or mist eliminators on its way downwards
- Here it comes into contact with the off-gas rising upwards through tray openings, capturing urea dust particles present

Any ammonia present in the off-gas has a low solubility in urea solution and, because of this, needs to be removed by a separate acidic scrubbing process. The scrubbing design and process is identical except that acid is added to the scrubbing solution to absorb ammonia and convert it to an ammonium salt. Urea dust and ammonia can be removed simultaneously in a single scrubber unit by circulating an acidified urea/salt solution to capture both. However, two-stage scrubbers that combine a separate dust scrubbing unit with an acidic scrubbing unit for ammonia removal are also common (Figure 1).

### Marketable by-products

Sulphuric acid and nitric acid can both be used for ammonia abatement in acidic scrubbing, producing either ammonium

sulphate (AS) or ammonium nitrate (AN) solution, respectively. The liquid fertilizer urea ammonium nitrate (UAN) can be obtained as a valuable by-product if nitric acid is selected to scrub ammonia-contaminated vent gases.

UFT offers *Ammonia Convert Technology* as an add-on system for sulphuric acid scrubbing at urea plants<sup>2</sup>. This concentrates the AS solution from the scrubber by evaporation, via a condensation/vacuum stage, and then adds it to the urea melt sent to the granulator. The resulting urea granules contain up to 0.1% sulphur. Alternatively, the AS solution can be crystallised and turned into pellets, using Sandvik's *Rotoform* granulator, for example.

Stamicarbon has its own technology for producing marketable urea ammonium sulphate (UAS) fertilizer from combined urea dust and ammonia scrubbing. A granulation plant with an output of 2,200 t/d would generate around 56 t/d of solid UAS (5% sulphur content) by adopting this approach.

Stamicarbon and UFT have also jointly developed a residue-free ammonia abatement process aimed at standalone ammonia-urea complexes that have no suitable outlet for acidic scrubbing by-products such as AS or UAN. This process proceeds as follows:

- Firstly, the acidic scrubbing of prilling or granulation off-gases takes place using sulphuric or nitric acid
- This is followed by electrolytic decomposition of the ammonium salts obtained
- Steam stripping then removes ammonia
- Finally, stripped steam and sulphuric/nitric acid are recycled and returned to the urea and scrubbing circuits, respectively

### Horizontal cross flow scrubber

UFT offers advanced scrubbing systems able to meet the new PM limits (particularly the limit for below 2.5 micron particles, PM<sub>2.5</sub>) and plume visibility limits for fluid bed urea granulation demanded by US authorities and others (Table 3).

This is a challenge as existing tray or impingement scrubbers are less effective at removing particles below 3 microns, and the numerous examples in current operation struggle to achieve emissions limits below 30 mg/Nm<sup>3</sup>. Urea dust emissions levels can be reduced to less than 20 mg/Nm<sup>3</sup> using fibre bed filters. But their high pressure drop and relatively large investment and running costs can make these systems an unrealistic option for large-scale, high air flow granulator plants.

Instead, UFT and Kimre opted to jointly develop a horizontal cross flow scrubbing system to meet the exacting new environmental standards. By last year, the system was already operating in over nine fertilizer plants with installations underway in another five.

In cross flow scrubbers, liquid moves downwards through the scrubbing media as the gas flows perpendicularly through it. The UFT/Kimre scrubber system combines up to five stages:

- A quench stage
- One or two dust removal stages, depending on emissions limits
- An optional acidic stage for ammonia removal
- A final demister stage

Large plants usually require separate granulator and granulator cooler scrubbing units (Figure 2).

In the quench stage, dust-laden out-gas flows horizontally through the scrubber and comes into contact with a set of pre-conditioning sprays. These saturate the gas and reduce the coarse-particle loading of the inlet gas before it makes contact with a series of wet pads in later stages. Urea solution is used in the quench stage and to spray the pads in the first dust removal

Fig 2: Horizontal cross-flow scrubbing system used in UFT plants

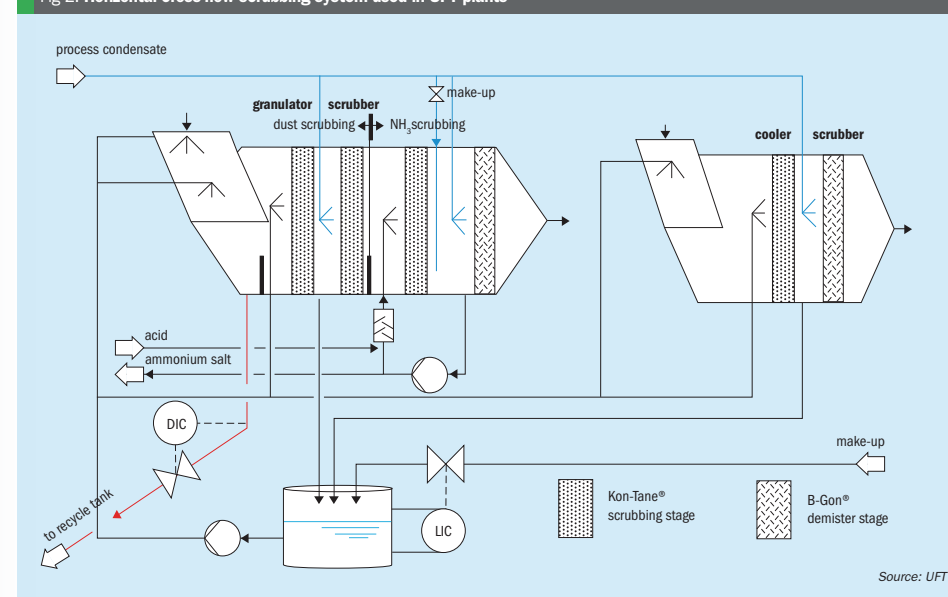

Source: UFT

1  
2  
3  
4  
5  
6  
7  
8  
9  
10  
11  
12  
13  
14  
15  
16  
17  
18  
19  
20  
21  
22  
23  
24  
25  
26  
27  
28  
29

IS AMMONIA  
FERTILIZING  
YOUR COOLING  
WATER?

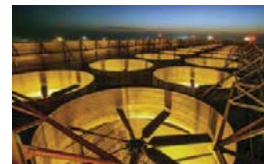

## REDUCE FOULING AND CHLORINE DEMAND WITH OXAMINE® FROM BUCKMAN.

**Ammonia contamination is rampant in fertilizer plants.** It gets into your cooling waters, accelerates bacterial growth and undermines the effectiveness of chlorine bleach and other conventional oxidizers. And that costs you time, money and lost production. That's why Buckman, a pioneer in cooling and process water protection since 1945, has developed Oxamine.

Oxamine works better than conventional oxidizing microbicides in high demand systems to keep cooling towers and heat exchangers cleaner, reduce chlorides and improve overall efficiency. It's better for the environment, too, and can reduce your plant's environmental footprint.

**Grow profits, not microorganisms.** Call your Buckman representative to find out how easy it is to switch to Oxamine, the better oxidizer for fertilizer.

**Buckman**

■ CONTENTS

What's in issue 469

■ COVER FEATURE 1

Citrus fertilisation

■ COVER FEATURE 2

Pakistan's fertilizer industry

■ COVER FEATURE 3

Phosphorus recovery finally breaks through

FERTILIZER INTERNATIONAL  
**ISSUE 469**  
NOVEMBER-DECEMBER 2015

**BCInsight**

Southbank House, Black Prince Road  
London SE1 7SJ, England

Tel: +44 (0)20 7793 2567

Fax: +44 (0)20 7793 2577

Web: [www.bcinsight.com](http://www.bcinsight.com)

[www.bcinsightsearch.com](http://www.bcinsightsearch.com)

Fig 3: Scrubber cutaway view with six stages indicated

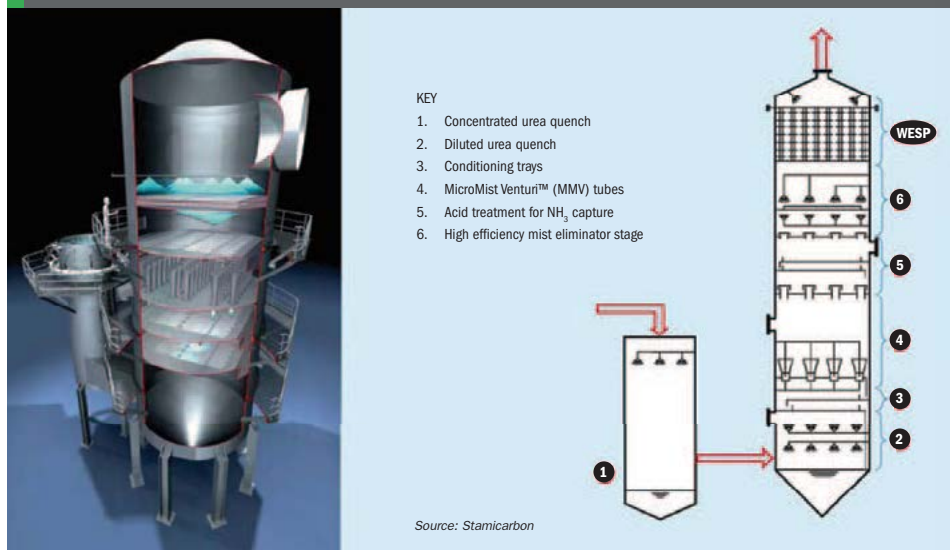

Source: Stamicarbon

stage, whereas clean process condensate is used to irrigate pads in the second dust removal stage. The spray nozzles are of a low pressure drop (<5 bar) design. The number of nozzles used, and the flow of liquid required, depends on the cross-sectional area of the pads, which in turn is determined by the air volume flowing through the unit.

An acidic stage for ammonia removal, with a separate acidic solution circuit, can be added downstream of the dust scrubbing section, if required. In the final demister stage, flushing with clean process condensate removes large droplets before the off-gas is discharged to the stack via the scrubber exhaust fan.

Kimre has also developed an aerosol removal system called *Aerosep* to meet US 'no visible emissions' requirements. An *Aerosep* stage in combination with the horizontal cross flow scrubbing system is compliant with all known requirements for ammonia,  $PM_{2.5}$  and plume visibility. Four *Aerosep* units were installed in fertilizer plants last year.

### Stamicarbon MicroMist Venturi technology

Stamicarbon and EnviroCare International have jointly developed an innovative, multi-stage scrubbing system which is highly

efficient at removing submicron dust and incorporates *MicroMist Venturi* (MMV) technology<sup>4</sup>. The system is designed to be installed alongside Stamicarbon's urea melt and fluid bed technology to ensure compliance with stringent new operating permits. Systems based on MMV scrubbing technology have been installed in at least five greenfield projects and one revamp project to date.

MMV scrubber technology is capable of reducing dust emissions to less than 10 mg/Nm<sup>3</sup> and consists of six stages (Figure 3), as follows:

- Concentrated urea (35-45%) *SpiralMist* quench
- Diluted urea (1%) quench
- Dual orifice impingement (DOI) conditioning trays
- *MicroMist Venturi* (MMV) tubes
- DOI trays with acid injection to sequester ammonia as AS or AN
- Highly-efficient mist elimination stage

The initial quenching stage removes around 98% of coarse particles. The subsequent two stages then remove any remaining coarse particles (greater than one micron) and also conditions smaller particles to enable their downstream removal by MMV. Submicron particles become coated with water and grow larger

due to condensation and agglomeration in water-saturated gas.

During the fourth stage, submicron-size particles are captured by *MicroMist* droplets as they accelerate, decelerate and collide together. The MMV tubes contain two nozzles, an atomisation nozzle (the *MicroMist* nozzle) at the entrance of each venturi tube and a second nozzle at the tube's throat. Particle-contaminated gas and the scrubbing liquid enter the throat and are mixed together at high energy, extremely turbulent conditions. Particles become entrained within water droplets and then exit into a diverging section where further collisions and agglomeration create larger, more easily-captured droplets.

Ammonia is removed by acidic scrubbing in the fifth stage by several DOI trays flooded with sulphuric or nitric acid. When urea dust and ammonia are captured separately, a 'chimney hat' tray section is used to prevent cross contamination between the urea dust scrubbing and the ammonia-capture stages.

Remaining suspended water droplets are removed from the gas stream before they leave the scrubber in the final mist eliminator stage. If required, a wet electrostatic precipitator (WESP) can be integrated into the scrubber vessel as an additional polishing stage to reduce particulate emissions to below 5 mg/Nm<sup>3</sup>.

### PROZAP cleaning units

PROZAP Engineering has over 20 years experience in the design and installation of industrial emissions scrubbing units, and particular expertise in dust and ammonia removal at urea and ammonium nitrate plants. More than 30 PROZAP cleaning units, with a capacity of up to 1.2 million Nm<sup>3</sup>/h, have been installed in new and existing nitrogen plants.

The firm's technology is particularly effective for urea and ammonium nitrate prilling towers. The units are said to operate at a scrubbing efficiency of 90% and are capable of reducing both dust and ammonia emissions to 25 mg/Nm<sup>3</sup>.

PROZAP's single-stage scrubber removes ammonia and dust simultaneously, and is offered as a suitable abatement solution for both granulator coolers and prilling towers. Granulator cooler out-gases have a relatively high dust load (up to 4 g/Nm<sup>3</sup>) but are typically ammonia-free. Out-gases from prilling towers contain relatively little dust and ammonia, in comparison to granulator emissions.

PROZAP's cleaning unit for urea granulators, in contrast, uses two stages to separately remove dust and ammonia (Figure 4). Granulator emissions have a higher dust load and a much wider range of particle sizes (1-1,000 µm) compared to

prilling tower (1-2 µm) and granulation cooler (1-100 µm) out-gases.

Intense spraying with concentrated 45% urea solution is used in the first stage of the cleaning unit followed by less intense spraying with 5% urea solution in the second stage. To remove ammonia, sulphuric or nitric acid is added to the second circulation loop.

The low pressure drop of PROZAP cleaning units reduces energy consumption during operation, allowing them to scrub large volumes of out-gases at relatively low cost. Pressure drops for PROZAP's single stage scrubber (800 Pa) and double stage version (1,600 Pa), for example, are much lower than those of sieve tray scrubbers (2,794 Pa). These performance differences should cut energy consumption. PROZAP says its single-stage unit operates at 1 kW/Nm<sup>3</sup> compared to 3.5 kW/Nm<sup>3</sup> for sieve tray designs. Because of this, PROZAP units can deliver annual energy savings of more than one million euros compared to some other scrubbing systems, according to the company.

### Fibre bed mist eliminator technology

MECS' *Brink* mist eliminators have been used in ammonium nitrate (AN) prilling tower installations for over forty years to control AN particulate emissions. A continuous improvement programme ensures the performance of this long-standing

technology keeps pace with the latest emission standards.

A new AN prilling tower scrubbing system recently installed in Brazil, for example, needed to reduce the plant's visible plume and keep AN levels in exhaust gases to less than 10 mg/Nm<sup>3</sup> and ammonia levels to less than 15 mg/Nm<sup>3</sup>.

The start-up of this new scrubber in 2013 marked the culmination of a 10-year retrofit project by MECS, Inc. (MECS) and the plant's operators. This included extensive research and development to optimise scrubber design and ensure very low level emissions at a constant operating pressure drop<sup>3</sup>. More recent advances in design have achieved operational particulate levels of less than 2.5mg/Nm<sup>3</sup> at El Dorado Chemical in Arkansas, USA.

The *Brink* High Efficiency (HE) mist eliminator has been improved a number of times since it was first developed in the 1950s. The *Brink* HE is constructed of a series of concentric wire mesh screens filled in-between with a fine fibre material. This design of mist eliminator is able to achieve removal efficiencies of between 90 to 99.9%+, depending upon the exact configuration and the type of installation.

Chemically-resistant glass fibre was used as the fibre media in the original HE mist eliminator. More recently, however, polymeric collecting fibres have been successfully used to extend operational life. The *Brink* Energy Saver (ES), a wrapped bi-component mist eliminator, was developed as an AN scrubber in the 1980s. The current range of *Brink* fibre bed designs, HE, HE Plus and ES, are exclusively available through MECS.

Technological innovation played a key role in delivering the performance improvements needed to lower emissions limits at the Brazilian AN prilling tower installation. In particular, a drainage control layer in the HE Plus fibre beds installed at the plant prevents high stack emissions caused by the re-entrainment of AN solution. ■

### References

1. Dirix, W. et al., 2014. High efficiency scrubbing technology for urea fluid-bed granulator exhaust gas. *Nitrogen+Syngas Conference 2014*.
2. Schmitz, M., 2012. Emission Control in Urea Plants During Normal Operating and Upset Cases – Why So Many Different Solutions? *Nitrogen+Syngas Conference 2012*.
3. Guimares, J. et al. 2015. Controlling particulate emissions from ammonium nitrate prill production. *International Fertilizer Society, Proceedings 768*.

Fig 4: Scrubber cutaway view with six stages indicated

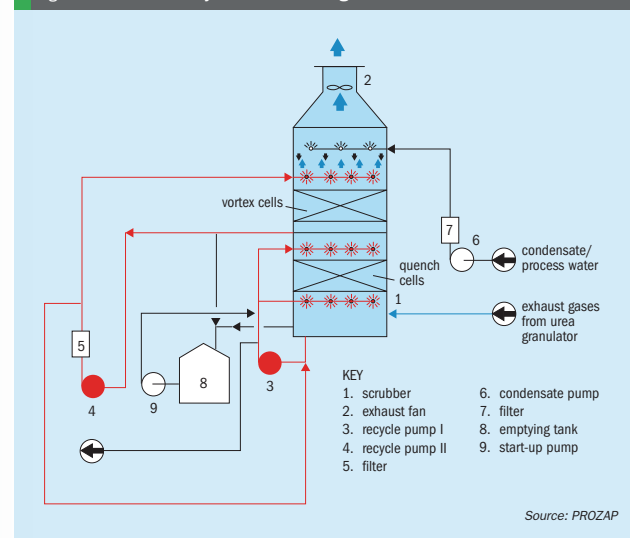

Source: PROZAP

## CONTENTS

What's in issue 469

## COVER FEATURE 1

Citrus fertilisation

## COVER FEATURE 2

Pakistan's fertilizer industry

## COVER FEATURE 3

Phosphorus recovery finally breaks through

FERTILIZER INTERNATIONAL  
**ISSUE 469**  
 NOVEMBER-DECEMBER 2015

**BCInsight**

Southbank House, Black Prince Road  
 London SE1 7SJ, England

Tel: +44 (0)20 7793 2567

Fax: +44 (0)20 7793 2577

Web: www.bcinsight.com  
 www.bcinsightsearch.com



# Asia's most resilient producer

Pakistan's fertilizer sector has emerged from a successful large-scale privatisation process as a modern, nine million tonne capacity industry serving a strategically-important agricultural sector. The country has also reacted to strong domestic fertilizer demand by making major investments in new and revamped plant capacity. We report on fertilizer production in Pakistan and its resilience in the face of periodic natural gas stoppages and curtailments.

Fig 1: Pakistan's fertilizer producers



**A**griculture remains a key pillar of Pakistan's economy, growing by 2-3% in each the last two years, contributing a fifth to national GDP and employing 43% of the country's workforce. Importantly, agriculture is also a large source of foreign exchange earnings for Pakistan, and underpins the cotton textiles sector, which grew by 7% last year and is the country's largest industry. In terms of major crops, Pakistan produced 14 million bales of cotton, 63 million tonnes of sugarcane, 25 million tonnes of wheat, 7.0 million tonnes of rice and 4.7 million tonnes of maize last year.

### Energy security versus food security

Almost all of Pakistan's soils are nitrogen-deficient, around 80-90% are phosphorus-deficient and some 30% potassium-deficient. They also suffer from long-standing nutrient imbalances. The country's farmers generally favour the application of N over P and K for economic as well as practical reasons. Nitrogen in the form of urea is cheap, locally-available and also provides farmers with a rapid crop response, whereas phosphate and potash are more expensive and partly imported.

The pattern of fertilizer consumption in Pakistan is a reflection of the relative balance of imports and domestic fertilizer availability. Changing that balance has become an increasingly difficult task due to mounting food and energy security pressures facing the Pakistan government.

The policy of natural gas curtailment, which has periodically diverted gas from the fertilizer industry to the power sector, has had a number of undesirable consequences (see box). As well as undermining investment in Pakistan's fertilizer sector, curtailment has resulted in domestic fertilizer price hikes, higher fertilizer import bills, depleted foreign exchange reserves and a greater subsidy burden for the state.

Despite this, Pakistan's fertilizer output has managed to remain surprisingly stable over the last five years and production remains a profitable activity for the country's main suppliers. Encouragingly, positive signs of a pick up in production also emerged at the start of this year.

### Four main players, five main products

Although no longer operative, the 50,000 t/a ammonium sulphate plant commissioned in 1958 by state-owned Pak American Fertilizers Ltd (now Agritech Ltd) was

IF IT DOESN'T SAY  
**“AGROTAIN®”**  
 IT'S NOT AGROTAIN®.

Don't be fooled by imitators. AGROTAIN® nitrogen stabilizer is the original, most research-proven urease inhibitor technology on the market. With 20 years of trials and real-world results on millions of acres worldwide, it's the one growers trust to protect their nitrogen investment and yield potential every time. Ask your retailer for AGROTAIN® stabilizer, or visit [agrotain.com](http://agrotain.com) to learn more.



THE POWER TO MAKE THINGS GROW

AGROTAIN® and the AGROTAIN logo are trademarks of Koch Agronomic Services, LLC in the United States and may be registered in other jurisdictions. The Koch logo is a trademark of Koch Industries, Inc. in the United States and may be registered in certain jurisdictions. AGROTAIN® brand stabilizers and other Koch Agronomic Services products are marketed by Koch Fertilizer Trading Sdn Bhd (successor to) and its distributors pursuant to authorized licenses. ©2015 Koch Agronomic Services, LLC. All rights reserved. 1-800-440-AGR\_International

CONTENTS

What's in issue 469

COVER FEATURE 1

Citrus fertilisation

COVER FEATURE 2

Pakistan's fertilizer industry

COVER FEATURE 3

Phosphorus recovery finally breaks through

FERTILIZER INTERNATIONAL  
**ISSUE 469**  
 NOVEMBER-DECEMBER 2015

**BCInsight**

Southbank House, Black Prince Road  
 London SE1 7SJ, England  
 Tel: +44 (0)20 7793 2567  
 Fax: +44 (0)20 7793 2577  
 Web: [www.bcinsight.com](http://www.bcinsight.com)  
[www.bcinsightsearch.com](http://www.bcinsightsearch.com)

Table 1: Fertilizer plants in Pakistan: operators, location, capacity and production

Operator*	Plant	Capacity	Product	Production ('000 tonnes)			
				2013/14	2012/13	2011/12	2010/11
FFC	Goth Machhi, RYK, Punjab [M]	1,330	Urea	1,577	1,587	1,567	1,665
FFC	Ghotki, Sindh (Pak Saudi) [M]	718	Urea	810	840	830	753
FFBL	Bin Qasim, Karachi [SSCGL]	551	Urea	210	257	353	484
EFERT	Old plant, Daharki, Sindh [SNGPL/M]	970	Urea	626	220	789	925
EFERT	New Plant, Daharki, Sindh [SNGPL/M]	1,260	Urea	1,165	855	413	132
FATIMA	Sadiqabad, RYK, Punjab [M]	500	Urea	357	296	416	425
FATIMA	Sheikhupura, Punjab (DHCL) [SNGPL]	445	Urea	43	47	143	336
FATIMA	Multan, Punjab (Pak Arab) [SNGPL]	120	Urea	7	-	18	54
AGRITECH	Mianwali, Punjab, (Pak American) [SNGPL]	429	Urea	136	113	157	219
<b>Total Urea</b>		<b>6,323</b>	<b>Urea</b>	<b>4,932</b>	<b>4,216</b>	<b>4,686</b>	<b>4,994</b>
FFBL	Bin Qasim, Karachi, Sindh [SSCGL]	675	DAP	694	727	619	664
<b>Total DAP</b>		<b>675</b>	<b>DAP</b>	<b>694</b>	<b>727</b>	<b>619</b>	<b>664</b>
FATIMA	Multan, Punjab (Pak Arab) [SNGPL]	340	CAN	96	27	229	274
FATIMA	Sadiqabad, RYK, Punjab [M]	340	CAN	423	375	397	301
<b>Total CAN</b>		<b>680</b>	<b>CAN</b>	<b>519</b>	<b>401</b>	<b>626</b>	<b>576</b>
FATIMA	Multan, Punjab (ex Pak Arab) [SNGPL]	350	NP	81	22	199	249
FATIMA	Sadiqabad, RYK, Punjab [M]	350	NP	356	270	271	8
EFERT	Bin Qasim, Karachi, Sindh [SSGCL]	40	NP	35	49	18	41
<b>Total NP</b>		<b>740</b>	<b>NP</b>	<b>472</b>	<b>341</b>	<b>489</b>	<b>298</b>
HFC	Jaranwala, Punjab (Lyalpur Chemicals)	108	SSP	8	28	63	75
AGRITECH	Haripur, Khyber Pakhtunkhwa (Hazara Phosphate) [SNGPL]	147	SSP	77	52	53	80
SURAJ	Harappa, Sahiwal, Punjab	150	SSP	-	21	49	44
<b>Total SSP</b>		<b>405</b>	<b>SSP</b>	<b>85</b>	<b>101</b>	<b>165</b>	<b>199</b>
EFERT	Bin Qasim, Karachi, Sindh [SSGCL]	160	NPK	64	42	59	68
<b>Total NPK</b>		<b>160</b>	<b>NPK</b>	<b>64</b>	<b>42</b>	<b>59</b>	<b>68</b>
<b>Total fertilizer production</b>		<b>8,983</b>		<b>6,765</b>	<b>5,828</b>	<b>6,643</b>	<b>6,797</b>

\*Shading indicates plants operating at less than 50% capacity.

Source: NFDC

Key:

AGRITECH	AgriTech Ltd	FFC	Fauji Fertilizer Company Ltd	FFBL	Fauji Fertilizer Bin Qasim Ltd
EFERT	Engro Fertilizers Ltd	FATIMA	Fatima Fertilizer Co Ltd	HFC	HFC, Allah Din Group
		SURAJ	Suraj Fertilizer Industries (Private) Ltd		

Pakistan's first nitrogen fertilizer plant. In 1962, a calcium ammonium nitrate (CAN) plant was built by another state company, Pak-Arab Fertilizer Ltd, at Multan in the Punjab. Esso Pakistan Fertilizer Company Ltd (now Engro Fertilizers Ltd) also started to produce urea from a plant at Dharki in the Sindh in 1968, following the earlier discovery of the nearby Mari gas field.

The industry has grown out all recognition over the intervening decades, driven by agricultural demand and the development of

large domestic natural gas reserves. Pakistan now boast 18 major fertilizer plants, 11 located in Punjab, six in Sindh and one in Khyber Pakhtunkhwa (Figure 1). Their combined capacity currently stands at 9.0 million t/a, split between urea, diammonium phosphate (DAP), CAN, NPK fertilizers and single super phosphate (SSP) production. Plant capacity is divided as follows:

- Urea, 6.32 million t/a (70.4%)
- NP/NPK, 0.90 million t/a (10.0%)
- DAP, 0.68 million t/a (7.5%)

- CAN, 0.68 million t/a (7.6%)
  - SSP, 0.40 million t/a (4.5%)
- As the above figures suggest, fertilizer manufacture in Pakistan is dominated by urea output from nine plants. In 2013/14, these collectively accounted for almost three-quarters (4.9 million tonnes) of the 6.8 million tonnes of domestically-produced fertilizers (Table 1). National production of nitrate (CAN), phosphate (DAP) and NP/NPK fertilizers is also appreciable, amounting to around 0.5-0.7 million tonnes for each of these

## Gas supply and curtailment

Since 2010, the availability, allocation and price of domestically-produced natural gas has become a key constraint on production, investment and expansion of the Pakistan fertilizer industry. Pakistan produces around 39 billion cubic metres of natural gas annually (bcm) from reserves of around 778 bcm (27.6 trillion cubic feet), sufficient for a further 19-20 years of production. Power plants (9.9 bcm), industry (8.5 bcm), home users (6.8 bcm) and the fertilizer sector (6.4 bcm) are the country's main natural gas consumers.

However, Pakistan's economy has been exposed to intermittent power outages and industrial shut-downs as gas demand in the country continues to outgrow supply. Demand exceeded supply by 15-19 bcm in 2012 and this domestic natural gas deficit could grow to 41-49 bcm by 2020, according to the Pakistan Institute of Petroleum. The government plans to address these shortfalls by sourcing imported gas supplied by pipeline or as liquid natural gas (LNG).

Pakistan's fertilizer industry is doubly vulnerable to gas shortages because – as well as needing natural gas as a power source – the country's urea producers are reliant on natural gas as an essential feedstock. Indeed, the consumption of natural gas as a raw material in urea manufacture accounts for around four-fifths (5.0 bcm/176 bcf) of total fertilizer industry usage.

Natural gas supply for the fertilizer industry comes from three principal sources. The Mari gas field supplies around 4.2 bcm (147

bcf) and two major gas distribution companies, Sui Northern Gas Pipelines Ltd (SNGPL) and Southern Gas Company Ltd (SSGCL), supply an additional 1.3 bcm (45 bcf) and 0.7 bcm (27 bcf) each. Yet the fertilizer industry has faced periods of natural gas curtailment of 20% or more since 2010, despite policy guarantees of high priority access to natural gas dating back to 2005.

The Mari field has gas reserves of 79 bcm (2.8 tcf), enough for another decade or more. Three-quarters of its output is dedicated to the fertilizer industry, with the remainder going to the power sector. FFC and Fatima's Sadiqabad plants all source gas from the Mari field and, as a consequence, have been less vulnerable to curtailment. Indeed, FFC's urea plants have been producing urea in volumes well above nameplate capacity.

Many plants on SNGPL and SSGCL networks, in contrast, are currently operating at 50% below capacity (Table 1). These include three urea operations, namely Agritech's Mianwali urea plant and the Sheikhupura and Multan plants operated by Fatima Fertilizers. Engro's new urea plant also experienced a 60% gas curtailment in 2011 and 2012, although it is now operating at near full capacity.

Overall, gas curtailments hit the Pakistan fertilizer industry particularly badly in 2012/13, cutting total production to below the 6 million t/a mark. Parts of the sector were reported to be operating at 13% of installed capacity in 2012, and some plants on the SNGPL network were only receiving gas for two days a week in early 2013. However, production subsequently recovered by 16% in 2013/14 compared to the preceding year, although a number of plants are still operating at well below nameplate capacity. ■

products annually. SSP is the other major fertilizer product manufactured domestically, although production dipped below 100,000 tonnes last year.

Ownership of the industry is divided between four main players, Fauji Fertilizer Co Ltd (FFC), Fatima Fertilizer Co Ltd, Engro Fertilizers Ltd, and Fauji Fertilizer Bin Qasim Ltd (FFBL). Three smaller-scale producers, Agritech Ltd, Suraj Fertilizer Industries (Private) Ltd and HFC, part of the Allah-Din Group, also contribute significantly to national fertilizer output (Figure 2).

## Post-privatisation consolidation

The privatisation of five state-owned producers by Pakistan's National Fertiliser Corporation – namely Pak Saudi Fertilizers Ltd (PSFL), Pak Arab Fertilizers Ltd, Pak-American Fertilizers Limited (PAFL), Hazara Phosphate Fertilizer Ltd (HPFL) and Layallpur Chemicals & Fertilizers Ltd – has consolidated fertilizer industry ownership.

FFC assumed control of Pak Saudi's Mirpur Mathelo urea plant in 2002. Pak-American's Mianwali urea plant and HPFL's Haripur SSP plant later became part of Agritech Ltd. Another former state company, Pak Arab Fertilizers Ltd, the Multan-based

Fig 2: Pakistan's fertilizer production by company, 2010-11 to 2013-14

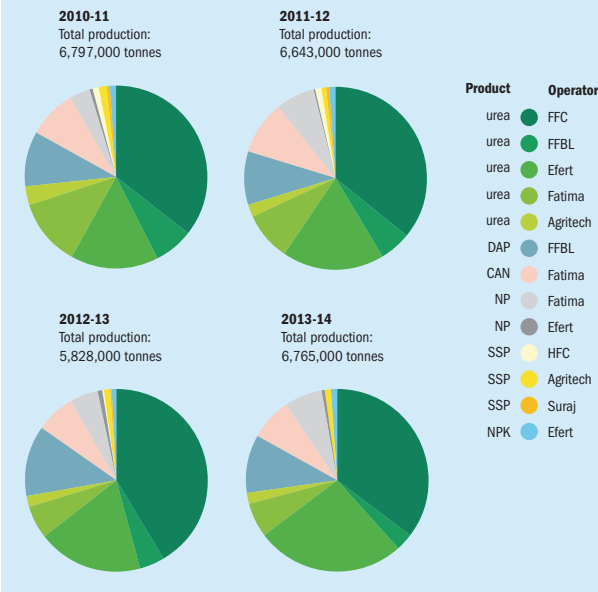
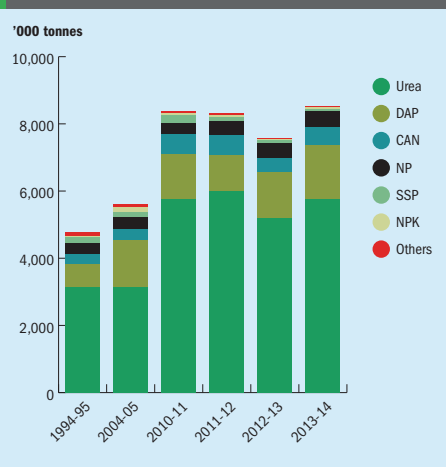

Fig 3: Fertilizer consumption (offtake) in Pakistan, 1994-95 to 2013-14



urea, CAN and NP producer, now operate as part of Fatima Fertilizers. Fatima also agreed the purchase of the loss-making Sheikhpura urea plant from Dawood Hercules Chemicals Corp Ltd in June this year.

**Urea and phosphate**

Rawalpindi-headquartered **Fauji Fertilizer Bin Qasim Ltd (FFBL)** is Pakistan's only DAP producer and, although technically an affiliate, it effectively operates as a subsidiary of **Fauji Fertilizer Co (FFC) Ltd**, the country's major urea producer. The two firms collectively own over a third (36%) of national production capacity, and FFBL's granular urea and DAP products are marketed and sold domestically under FFC's *Sona* fertilizer brand name, one of the most popular and widely-distributed fertilizer product ranges in Pakistan. FFBL sources phosphoric acid for DAP production from Pakistan Maroc Phosphore, its joint venture with OCP. The firm manufactures both granular urea and DAP at its \$468 million Bin Qasim fertilizer complex near Karachi.

FFC first became a urea producer in 1978 as part of a joint venture between the Fauji Foundation and Denmark's Haldor Topsoe. Its two Goth Machhi plants in the Punjab, together with the former Pak Saudi Fertilizers Ltd (PSFL) Mirpur Mathelo plant at Ghotki in the Sindh, enabled FFC to produce 2.4 million tonnes of urea last year.

Fig 4: Fertilizer production and imports in Pakistan, 2010-11 to 2013-14

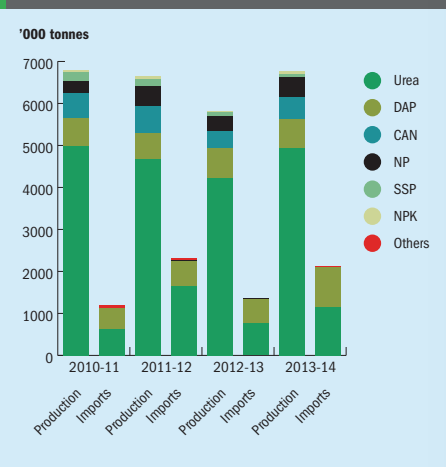

A revamp of the 1982 Goth Machhi I plant in 1992 increased capacity to 695,000 t/a. An additional 635,000 t/a of production capacity was then added the following year with the commissioning of the Goth Machhi II expansion unit. The capacity of the 1980 Mirpur Mathelo plant also increased to 718,000 t/a as part of a 2009 revamp project.

FFC has successfully weathered the gas curtailment problems of the last five years and generally produced urea above nameplate capacity at both its sites.

**The diverse player**

**Fatima Fertilizers**, arguably Pakistan's most diversified fertilizer manufacturer, operates just over a quarter of national fertilizer production capacity and is the country's only domestic CAN producer. Its modern, large-scale Rahim Yar Khan fertilizer complex, at Sadiqabad in the Sindh, manufactures urea, CAN and NP fertilizers. The complex is supplied by a 110 million cubic feet per day (mcf) gas allocation from the Marf field and commenced production in July 2011.

Fatima also took control of another urea, CAN and NP complex at Multan, Punjab, after purchasing Pak Arab Fertilizers Ltd from the Pakistan state. The 1978 Kellogg-process ammonia plant at Multan was upgraded to 960 t/d in 1986 and supplies a 300 t/d urea plant which employs SAIPEM ammonia-stripping technology.

DHFL's Sheikhpura urea plant in the Punjab also became Fatima-owned following a PKR 2 billion (\$19.2 million) deal over the summer. The Fluor-built plant dates from 1971 although a revamp in 1991 expanded capacity to 1,350 t/d.

**The world class Daharki urea plant**

The fertilizer complex at Daharki, Sindh owned by **Engro Fertilizers Ltd (EFL)** includes Pakistan's most modern and highest-capacity urea plant. The company also owns an NPK plant at Bin Qasim in the Sindh.

The firm operates two high-capacity urea plants at Daharki. The original plant dates from 1968 but was upgraded from 173,000 t/a to 970,000 t/a capacity in 1991. The company's second Daharki plant, the \$1.1 billion 'Enven' project, has a 1.26 million t/a nameplate capacity and was the world's largest single-train urea plant when it came into operation in 2010. The Enven plant operated at close to full capacity last year but got off to a faltering start due to gas curtailments and only received gas for 189 days in 2011 and 45 days in 2012.

As well as being a large volume seller of urea in Pakistan, Engro's fertilizer brands include *Zarkhez*, an NPK fertilizer for sugar cane, fruit orchards, potato and tobacco farming, and *Zingo*, a micronutrient fertilizer. Importantly, both Engro and FFC are also major importers of DAP into Pakistan.

**Superphosphate producers**

**Agritech Ltd** markets and sells the *Tara* brand of urea and SSP fertilizers manufactured at two plants located in Mianwali, Punjab, and Haripur, Khyber Pakhtunkhwa, respectively. The Mianwali urea plant was converted to the Stamicarbon process as part of a major revamp project in 2011 which increased production capacity to 1,420 t/d.

Agritech produced 77,000 tonnes of SSP in 2013/14 and is one of three SSP manufacturers in Pakistan. **Suraj Fertilizer Industries (Private) Ltd** owns and operates a modern, sophisticated sulphuric acid (75,000 t/a) and SSP (150,000 t/a) complex in Harappa near Sahiwal in the Punjab. The company sells *BADSHAH* brand SSP granules and powders as a source of Ca, P, S and micronutrients, although no SSP was manufactured at Harappa in 2013/14, according to NFDC figures.

**HFC**, part of AllahDin Group, also owns a sulphuric acid (40,000 t/a) and SPP (100,000 t/a) complex at Jaranwala, Punjab, following its purchase of state-owned Lyallpur Chemicals & Fertilizers Ltd in 2007. The SSP produced at Jaranwala, which dates from 1968, is sold under the *Kissan*

and *Chand* brand names. HFC also markets the *Bio-Gold/Bio-Star* range of bio-fertilizers.

**Large domestic demand**

Punjab continues to be the food basket of Pakistan, cultivating cereals such as rice and wheat over a 17.2 million hectare area, a total that has increased by an impressive one million hectares in the last decade as more marginal land has been brought into production. Sindh province ranks next in terms of cropped area (3.5 million hectares) followed by Khyber Pakhtunkhwa (KPK, 1.6 million hectares) and Balochistan (1.1 million hectares).

Annual fertilizer consumption has fluctuated at between 7.6-8.5 million tonnes over the last four years (Figure 3). Imports correspondingly varied at between 1.2-2.3 million t/a over this period to meet demand, and were particularly high in 2011/12 and 2013/14 (Figure 4).

State controlled urea imports rose by over a million tonnes in a single year to reach 1.6 million tonnes in 2011/12 – but have fallen back since then. The market for imported DAP, in contrast, has shown consistent growth in recent years,

with volumes rising year-on-year from 0.5 million tonnes in 2010/11 to 0.7 million tonnes in 2013/14.

**Nutrient imbalances**

Pakistan's nutrient consumption has risen fourfold on a NPK basis, growing from one million t/a in the early 1980s to pass the four million t/a threshold last year. Yet the average ratio for NPK use in Pakistan of 1:0.3:0.01 (N:P<sub>2</sub>O<sub>5</sub>:K<sub>2</sub>O) has changed remarkably little in the last 15 years. The extent of long-standing nutrient imbalances is revealed by the gulf between recommended crop application rates in Pakistan and actual agricultural practice (Table 2).

**Producer prospects**

Signs from earlier this year suggest that Pakistan's production has continued to recover from the periodic bouts of curtailment of the previous four years. A year-on-year urea sales increase of 8% was reported for January/February 2015, for example. DAP production this year also reached 0.9 million tonnes by September, supplemented by DAP imports of around 0.65 million tonnes. DAP demand and imports are likely to grow following the introduction of phosphate subsidies in October.

The long-term prospects for Pakistan's fertilizer industry depend on securing cheap, reliable and uninterrupted supplies of natural gas. Fortunately, there are encouraging recent signs of progress on this. Pakistan's Oil and Gas Development Company Ltd, for example, has signed a gas supply agreement (GSA) to directly sell 130 mcf of natural gas from the Kunar Pashaki Deep gas field to four urea plants owned by Engro, Fatima and Agritech, enough to meet 54% of their gas requirements. In July, Engro Elengy Terminal Ltd, the fertilizer producer's sister company, also received first shipments through a new \$145 million, 600 mcf LNG terminal at Bin Qasim.

Two pipeline projects for importing natural gas took a step forward this year as well. In April, Pakistan struck a preliminary deal with China to build a so-called 'Peace Pipeline' with Iran. The project involves the construction of a \$2 billion gas pipeline within Pakistan to link-up with an already completed 560 mile section of pipeline on the Iranian side of the border. Russian state-owned construction company Rostec also announced its own plan for a rival \$2.5 billion, 680-mile, Russia-Pakistan gas pipeline project in August.

Table 2: Average NPK use versus actual application rates in Pakistan, 2007-08

	Nitrogen (kg/ha)	Phosphorus (kg/ha)	Potassium (kg/ha)	Total
<b>Punjab</b>				
<b>Average use</b>	<b>107</b>	<b>41</b>	<b>1.9</b>	<b>149.8</b>
Recommendations:				
Wheat, irrigated	75-160	60-110	60	
Wheat, rainfed	60-100	60-75	60	
Paddy rice	75-160	67	60	
Cotton	120-170	60	60	
Sugarcane	170-270	60-110	60-120	
Maize	60-90	60	-	
Pulses	20-30	60-90	-	
<b>Sindh</b>				
<b>Average use</b>	<b>159</b>	<b>61.3</b>	<b>2.3</b>	<b>222.6</b>
Recommendations:				
Wheat, irrigated	130-170	50-90	50	
Paddy rice	134-180	67-100	50	
Cotton	90-140	60	50	
Sugarcane	200-300	100-125	100-170	
Pulses	90-120	60	-	
<b>Pakistan</b>				
<b>Average use</b>	<b>130</b>	<b>37.8</b>	<b>1.2</b>	<b>169.0</b>

Source: Iqbal et al., 2015, NFDC/FAO

CONTENTS

What's in issue 469

COVER FEATURE 1

Citrus fertilisation

COVER FEATURE 2

Pakistan's fertilizer industry

COVER FEATURE 3

Phosphorus recovery finally breaks through

FERTILIZER INTERNATIONAL  
ISSUE 469  
NOVEMBER-DECEMBER 2015

BCInsight

Southbank House, Black Prince Road  
London SE1 7SJ, England  
Tel: +44 (0)20 7793 2567  
Fax: +44 (0)20 7793 2577  
Web: www.bcinsight.com  
www.bcinsightsearch.com

# The Growth for Uganda project

K+S KALI GmbH has been providing thousands of Uganda's farmers with fertilisation training as part of a joint project with the Sasakawa Africa Association. The project is part of wider attempts to improve agricultural productivity and food security in the region. K+S KALI report on the project's achievements to date.



Programme officer Daniel Olol provides training.

**B**oosting farm incomes by helping rural smallholders become more agriculturally productive and self-sufficient is the main aim of *Growth for Uganda*, an ambitious project led by major European fertilizer producer K+S KALI GmbH and the Swiss-headquartered NGO the Sasakawa Africa Association (SAA).

The project is setting up an advice network for Uganda's farmers offering help and information on appropriate fertilisation. As well as providing much-needed educational outreach for farmers, the project has an important research objective as well. It wants to promote the use of soil analysis for site-specific fertilisation recommendations.

"We firmly believe that both farmers and people in Uganda will benefit from this over the long term," said Norbert Steiner, K+S KALI board chairman, during the official signing of contracts to mark the launch of the project in Kassel, Germany, in April 2013.

## Turning potential into yield

Uganda is often called "the pearl of Africa" because of its beauty and unspoilt natural environment. However, the country and its inhabitants face enormous problems. About two-thirds (67%) of Uganda's rapidly growing population are either poor or highly vulnerable to poverty, around a fifth of households (21%) are moderately food

insecure and some 6% are classed as food insecure. The two-thirds of the population that live in the countryside also rely on subsistence farming to feed their families. Large disparities in income and wealth in Uganda are mirrored by inequalities in the health of its people.

The main driving force behind the *Growth for Uganda* project is the strong need to improve Ugandan agriculture and address the needs of local people in the countryside. K+S KALI and SSA have collaborated together to develop an agricultural consultancy service for the East African country as part of the project.

Soils in Uganda are reasonably fertile although they can lack important nutrients such as potassium, and only a small percentage of fields are irrigated. Fertilizer use on cultivated land averages less than 1 kg per hectare a year. This is low even by African standards. Comparable application rates are 3 kg/ha for the Sub-Saharan Africa region and 8 kg/ha for Africa as whole.

Soil fertility and crop yields will decline further if nutrients continue to be taken from the soil during harvesting without being replaced. This is the reason why African Union countries are aiming to increase the use of fertilisers to at least 50 kg per hectare of cultivated land by 2015.

Most farmers grow crops to cover their own needs, farming 1 to 3 acres (0.4 to 1.2 hectares) each on average. The crops harvested on this area must be sufficient to feed an average family of seven. Corn, cassava, beans, soybeans, rice, sesame, millet, sweet potatoes, peas, sunflowers, manioc, coffee, tea, cotton and bananas are all commonly grown in Uganda. Wheat and barley are also cultivated in the country's highlands. On the death of a smallholder, land is usually divided between heirs, a practice that leaves smaller and smaller plots for the following generation to subsist on.

## Cultivation training

At the start of the project in 2013, K+S KALI and SAA set up a mobile unit to help train a large number of plant cultivation consultants in Uganda. The wide-ranging training also covered post-harvest handling, storage, processing and market access. In addition, the development of best management practices for corn and cassava were also prioritised, as these are the region's two most important cultivated crops.

The project is also proving to be highly valuable for K+S KALI, as it has improved

the company's understanding of the situation facing African smallholders, and provided insights into the functioning of local markets. This will enable K+S KALI to better tailor its product range to African needs in the long run – a transfer of knowledge that is beneficial for both sides.

SAA has been advising smallholders on how to enhance crop productivity in Uganda since 1997. SAA's advisory teams are made up of expert programme officers. In 2013, one of these officers, a young Ugandan agronomist, Daniel Olol, stayed in Germany for training at K+S KALI and the Institute for Applied Plant Nutrition (IAPN). Daniel's current mission in Uganda is to pass on his knowledge and help establish regular plant nutrition according to the particular demands of crops.

"The yields that our farmers actually achieve are considerably lower than the yield potential. There is a lack of specialist knowledge", says Olol. He describes how SAA addresses the issue: "We teach groups of smallholders by involving them in what we call Farmer Learning Platforms. These platforms incorporate demonstration experiments, teaching units, skills mentoring and specialist support through SAA."

## Reducing nutrient mining

SAA's outreach work is based on Farmer Learning Platforms (FLPs) with three main elements:

1. **Participatory training sessions** with extension agents and farmers;
2. **On-farm field demonstrations** which serve as learning sites for farmers to study the effects of improved technologies; and
3. **Continuous monitoring and evaluation** of activities, feedback and specialist support.

Three different fertiliser application rates are used in field demonstrations and their effects are then jointly evaluated with extension agents:

- Traditional cultivation practices without the application of mineral fertilisers
- Application rates for nitrogen (N), phosphorus (P) and potassium (K) according to the recommendations of regional research institutes
- NPK application rates at 50% less than scientific recommendation for farmers with less resources

Field demonstrations therefore offer farmers several options and enable them to act according to the resources available. There are two key messages from this:

- Firstly, productivity can be improved
- Secondly, fertiliser use, best agricultural practices and capacity building can convert subsistence farming into profitable enterprises, thus reducing nutrient mining and ensuring sustainable productivity

One of the main challenges faced by SAA, besides knowledge transfer, is the limited access to agronomic inputs such as seed and fertilizer in Uganda. Most farmers have only limited financial resources to buy these and are only able to afford small amounts. To assist with this, SAA and K+S KALI now have a new project partner, Savannah Commodities. Initially a coffee trader and exporter, Savannah is currently building a bulk blending plant to produce several fertilizer blends tailored to the requirements of individual crops. These will be sold in single-portion packages ranging from 2 kg to 50 kg in size.

# Köppern



## Dry granulation of fertilizers

Our technology has been recognized around the world for dry granulation of MOP/SOP and NPKs. Our services cover pilot plant tests, basic engineering, equipment supply, start-up supervision, and commissioning. Typical flake capacities are in the range of 10–130 t/h or more.

We have received orders for more than 70 fertilizer compactors of latest Köppern technology since the year 2000. The total installed flake capacity of these plants is exceeding 60,000,000 tpa.

**Köppern – Quality made in Germany.**

- State of the art technology
- Process technology know-how
- High plant availability
- Quick roller replacement

[www.koepfern.de](http://www.koepfern.de)

CONTENTS

What's in issue 469

COVER FEATURE 1

Citrus fertilisation

COVER FEATURE 2

Pakistan's fertilizer industry

COVER FEATURE 3

Phosphorus recovery finally breaks through

FERTILIZER INTERNATIONAL  
**ISSUE 469**  
NOVEMBER-DECEMBER 2015

# BCInsight

Southbank House, Black Prince Road  
London SE1 7SJ, England

Tel: +44 (0)20 7793 2567

Fax: +44 (0)20 7793 2577

Web: [www.bcinsight.com](http://www.bcinsight.com)  
[www.bcinsightsearch.com](http://www.bcinsightsearch.com)

K+S KALI has helped Savannah develop the composition of its blended fertilizers by adjusting their N, P, K and Mg content to take account of recent research findings on crop needs. The availability of these new blended products will aid and simplify fertilisation for Ugandan farmers. Savannah is also supporting the project by storing and marketing agricultural produce on behalf of farmers.

### Soil laboratory and training unit

The *Growth for Uganda* project is being delivered using a proven SAA model. The aim is to train about 50,000 smallholders during the project's first three years. SAA consultants initially trained 10,000 smallholders in the Dokolo and Apac districts between April and August 2013. Numbers have risen over time and, by the summer of this year, a total of 35,000 farmers had participated in the project.

The key tool for delivering this training is the project's Mobile Farmers' Training Centre – also known as “the truck”. The keys to this all-terrain vehicle, with its mobile training unit and soil laboratory, were symbolically handed over to the acting minister of agriculture, the Hon. Ruth Nankabirwa, Uganda's state minister for fisheries, during the Jinja agricultural show in July 2014. Prof. Dr. Andreas Gransee attended the event on behalf of K+S KALI.

“Our mobile training centre has already been in operation at many training events since the beginning of the year,” comments Dr Gransee. “This vehicle opens up new possibilities for providing farmers in remote areas with knowledge about improved methods of cultivation.”

He continues: “Equipped by experts in Germany for deployment under extreme conditions, the five tonne truck is able to reach villages even under truly adverse road and weather conditions. With its soil analysis module, specifically developed for mobile use, the vehicle equally meets our scientific requirements and those of Ugandan infrastructure – it really is unparalleled.”

More than 2,000 farmers have been trained since the mobile training centre entered service.

### On the road in Uganda

Agronomist Daniel OloI was the first programme officer for enhanced crop productivity to be trained at the IAPN at Göttingen University and the K+S KALI Research

Institute in Heringen, Germany. By going on the road with “the truck”, he has been able to pass on his knowledge to both educators and smallholders, as well as working on solutions for more sustainable crop nutrition with his trainees. In autumn 2014, a second programme officer, Christine Kyomugisha from SAA, also received professional training in Germany.

“When we show the farmers that they can double or even triple their yields by following our training, they are really excited and can't wait to try out what we are teaching them”, says Daniel OloI. “We already have success stories of farmers whose income has increased dramatically through practicing what they learnt from the project. And, of course, when other farmers see such results, they are challenged to copy this approach and improve their livelihoods as well. From my point of view, the project has an enormous potential to change lives of smallholders in Uganda.”

“Our mobile training vehicle opens up new possibilities for farmers in remote areas.”

### Global research activities

The involvement of K+S KALI in agricultural research dates back more than 100 years. Throughout its long history of research, K+S KALI has sought to address key agronomic challenges such as how to increase crop productivity, improve soil fertility and use finite resources more efficiently.

Over the years, K+S KALI has established and maintained strong ties with numerous global scientific institutions and experts. Its international scientific collaboration includes field trials on balanced fertilisation in countries such as Ghana, Ecuador, Kenya, Ethiopia, India and Pakistan, to mention just a few. Findings are publicised and translated into agricultural practice via the company's advisory service and through publication in leading scientific journals.

One key, long-standing objective of this research has been the maintenance or enhancement of soil health and fertility – as a necessary prerequisite for high

yields and quality produce. Drawing on vast experience in plant nutrition, agronomists at K+S KALI provide advice and assistance in many regions of the world. They are able to inform farmers about major nutrients (potassium, magnesium, sulphur and sodium) as well as the micronutrients (boron, manganese and zinc).

K+S KALI manages its own research institute, the Institute of Applied Plant Nutrition (IAPN), in collaboration with the Georg-August-University in Göttingen, Germany. Research at IAPN is addressing the latest issues in plant nutrition. Developing solutions for improving food security, finding more efficient ways of using resources and turning research findings into agricultural practice are all major priorities at IAPN – an approach which is perfectly in line with the key objectives of K+S KALI.

Prof. Dr. Andreas Gransee, the Director of the Applied Research and Advisory Service Agro at K+S KALI, is deeply involved in agronomic research and training.

“Providing training is absolutely vital for improving livelihoods in developing countries,” says Gransee. “That is why K+S KALI is playing an active role in international development co-operation in general and the *Growth for Uganda* project in particular – we want to share our knowledge and contribute to international networks.”

He continues: “Agriculture has a great potential for reducing poverty in developing and emerging countries. With our combination of laboratory work, field trials and knowledge transfer, we can provide a lasting impetus towards making this potential achievable.”

### Heavyweight backing

The International Fertilizer Industry Association (IFA) has given its backing to international cooperation and outreach projects such as *Growth for Uganda*. IFA's leadership strongly supports efforts to address food security and hunger, as shown by its 2013 annual report.

“Only by cooperation between the private sector, research institutes, the public sector and regional, national and supra-national governance can we face the challenges that lie ahead in our battle against hunger and malnutrition,” wrote former IFA president, Esin Mete.

These comments chimed with those of IFA's director general, Charlotte Hebebrand, who added: “The level of knowledge about fertilizers remains low. A key objective of IFA's strategic plan... is therefore to redouble our outreach in education efforts.” ■

# BREAK THE MOLD

Koch Agronomic Services is breaking new ground in the growing enhanced efficiency fertilizer market with N-TEGRATION™ Technology, an innovative platform now available for licensing to qualified fertilizer manufacturers. With N-TEGRATION™ Technology, fertilizer producers can integrate specifically engineered additives into prilled or granular urea to create a differentiated product – one that can demand a higher premium in the marketplace while addressing the growing industry need for nitrogen loss prevention.

To learn more about N-TEGRATION™ Technology, visit [n-tegration.com](http://n-tegration.com), or to see if you qualify for the licensing program, contact your Koch Agronomic Services representative.

**N-TEGRATION™**  
TECHNOLOGY

[n-tegration.com](http://n-tegration.com)

N-TEGRATION™ and the N-TEGRATION Logo are trademarks of Koch Agronomic Services, LLC in the United States and may be registered in certain jurisdictions. The Koch logo is a trademark of Koch Industries, Inc. in the United States and may be registered in certain jurisdictions. Koch Agronomic Services products are marketed by Koch Fertilizer Trading SRI Saccalal Uruguay and its distributors pursuant to authorized licenses. © 2015 Koch Agronomic Services, LLC.

**KOCH**  
AGRONOMIC SERVICES

THE POWER TO MAKE THINGS GROW

CONTENTS

What's in issue 469

COVER FEATURE 1

Citrus fertilisation

COVER FEATURE 2

Pakistan's fertilizer industry

COVER FEATURE 3

Phosphorus recovery finally breaks through

FERTILIZER INTERNATIONAL  
**ISSUE 469**  
NOVEMBER-DECEMBER 2015

**BCInsight**

Southbank House, Black Prince Road  
London SE1 7SJ, England  
Tel: +44 (0)20 7793 2567  
Fax: +44 (0)20 7793 2577  
Web: [www.bcinsight.com](http://www.bcinsight.com)  
[www.bcinsightsearch.com](http://www.bcinsightsearch.com)

Our ideas make  
**profitable plants**



## World class phosphoric acid technology

We offer advanced solutions for:

- phosphoric acid production
- phosphoric acid concentration
- fluorine recovery
- gas scrubbing
- phosphoric acid purification
- gypsum purification
- uranium recovery

Our services include:

- process design
- plant surveys and revamping
- effluent surveys
- process training
- phosphate rock tests

With more than  
**50 years' experience,**  
**Prayon Technologies**  
**has developed a unique**  
**expertise in designing**  
**phosphoric acid plants.**  
**Our mission is to**  
**optimise your plant**  
**performance**  
**and increase its**  
**profitability.**

[www.prayon.com/technologies](http://www.prayon.com/technologies)

Prayon Technologies s.a. | Rue J. Wauters, 144 | B-4480 Engis | Belgium  
 Tel : + 32 4 273 93 41 | Fax : + 32 4 275 09 09 | Email : prt@prayon.be



PRAYON

# Phosphorus recovery finally breaks through

The installation of a struvite harvesting system at the world's largest wastewater treatment plant in Chicago, Illinois, demonstrates the increasing economic viability of phosphorus recovery. The commercial deployment of struvite crystallisation technology is now gathering pace internationally, although a number of other P recovery technologies, currently at the demonstration plant stage, are also poised to take off.

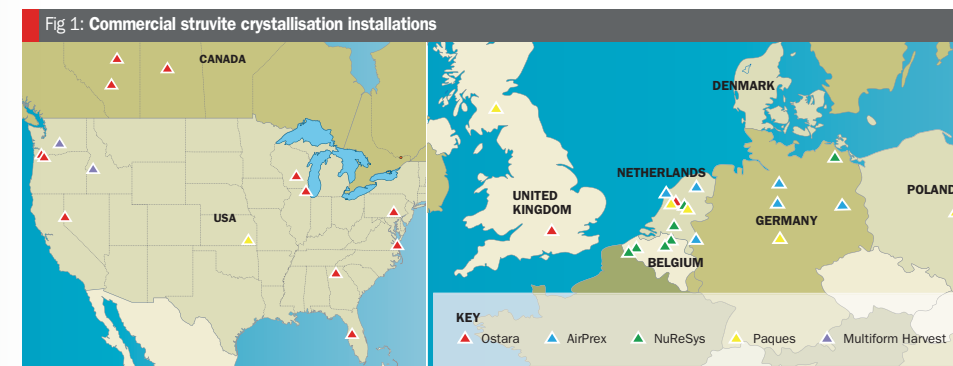

Of all the economic and environmental concerns about phosphorus production and consumption globally, the need to address life cycle wastage and losses is possibly the most pressing and compelling. The global resource efficiency for P from farm to fork is just 20% and, consequently, only 45 million tonnes of the 225 million tonnes of phosphate rock mined globally ends up in the form of food, according to recent estimates. Reducing life cycle losses is particularly critical if phosphate resource efficiency is to be improved and nutrient management shifted onto a more sustainable footing. Although the IFDC's 2010 phosphate resources assessment found no evidence of 'peak' phosphorus, it still recommended that economic phosphorus recovery should be maximised<sup>1</sup>.

It is therefore encouraging that phosphorus recycling and recovery has progressed beyond the technical feasibility stage and is increasingly entering

production on a commercial scale. Phosphate fertilizer production capacity from around 40 recovery plants worldwide has now reached the 10,000 t/a mark (Figure 1) with more large-scale plants due to be commissioned this year and next<sup>2</sup>.

The deployment of P recovery technology at these plants, and the fertilizers they produce, arguably holds the key to addressing many of the long-standing concerns over the supply, production and use of phosphates. Importantly, the growing numbers of full-scale municipal and industrial installations are proving that the recovery of phosphate can be both economically viable and environmentally beneficial.

The technical and economic performance of the main commercial phosphate recovery technologies, together with examples of their adoption, are reviewed below. A number of wastewater technologies, notably *AirPrex*, *Pearl*, *NuReSys*, *Paques*, *Multiform Harvest* and *Crystalactor*, are already being

deployed at full-scale. Other innovative, emerging technologies such as the Stuttgart and Gifhorn sludge leaching processes, and the sludge ash technologies *Mephrec*, *LeachPhos* and *AshDec*, are currently being piloted or are at the demonstration stage.

### Phosphorus recovery by struvite crystallisation

Struvite crystallisation is emerging as the leading commercial P recovery technology globally due to its adoption at a growing number of full-scale installations around the world. The technology is particularly suitable for wastewater treatment plants (WWTPs) where the enhanced biological phosphorus removal (EBPR) process is practiced.

In EBPR, phosphorus accumulating organisms (PAOs) are used to capture phosphate in waste activated sludge (WAS). But the combination of EBPR and anaerobic digestion (AD) at many WWTPs

Fig 2: The AirPrex struvite crystallisation process from sludge

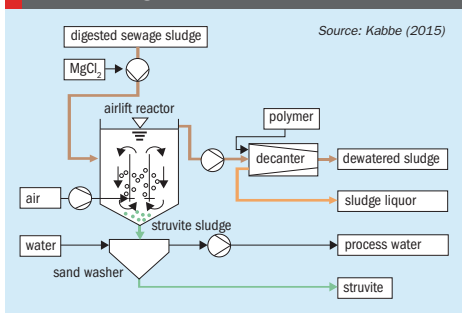
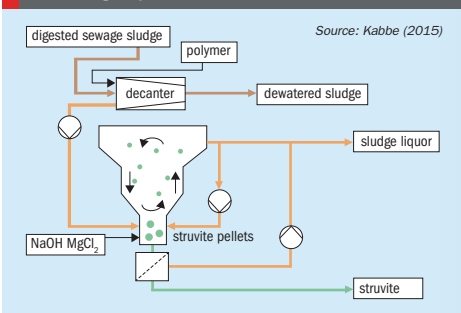

Fig 3: The Pearl struvite crystallisation process from sludge liquor



can have major drawbacks, as the resulting release of water-soluble P, Mg and NH<sub>4</sub> can cause a damaging build-up of struvite (NH<sub>4</sub>MgPO<sub>4</sub>·6H<sub>2</sub>O) on pipes, valves and other plant equipment.

The AirPrex process developed by Hamburg-based **cnp Technology Water and Biosolids Corporation** is specifically designed to prevent this kind of unwanted struvite precipitation at treatment plants. The firm's trademark struvite removal process reduces soluble phosphate by 90-95%, increases sludge dewatering efficiency and reduces plant maintenance costs by up to 50%. In Germany, the installation of AirPrex units at Wasmansdorf and Nuewerk WWTPs has cut annual operational costs by several hundred thousand euros<sup>3</sup>.

In the AirPrex process, the high pH conditions necessary for struvite crystallisation are created by CO<sub>2</sub>-stripping aerated sewage sludge in a proprietary AirLift reactor. Magnesium chloride solution is also added to the vessel to promote struvite crystallisation. Over time, struvite crystals grow, settle and eventually accumulate at the conical base of the reactor, once they reach a certain size (Figure 2). Struvite harvested from the AirPrex process is washed, dried and sold as *Berliner Pflanze*, a fertilizer product approved and registered by the Berliner Wasserbetriebe in Germany.

The AirPrex process has been installed on a commercial scale at four WWTPs in Germany and two WWTPs in the Netherlands (Figure 1):

- The 120 million gallons per day (Mgal/d) Berlin Wassmansdorf WWTP
- The 99 Mgal/d Nuewerk WWTP in Mönchengladbach
- The 8.5 Mgal/d capacity Uelzen WWTP
- The 12 Mgal/d Salzgitter WWTP

- The 100 Mgal/d Amsterdam West WWTP
- The 19 Mgal/d Echten WWTP

The first AirPrex installation in China, at the 90 Mgal/d Tianjin WWTP in Heibei province, was due to become operational in July.

The rival Pearl process offered by **Ostara Nutrient technologies Inc** is again designed to prevent the unwanted accumulation of struvite at EBPR-type treatment plants. The process originated in Canada and took 15 years to develop in collaboration with the University of British Columbia<sup>2</sup>.

The Pearl reactor vessel, an inverted, pyramid-shaped fluidised bed, is installed at WWTPs to treat liquor separated from sludge by mechanical dewatering. The Pearl process reduces phosphorus loading at WWTPs by 20-40% and ammonia loading by 5-15%, according to Ostara.

Struvite is precipitated by dosing with MgCl<sub>2</sub> and raising the pH using caustic soda (NaOH). The reactor's unique design allows large prills (up to 8 mm diameter) to form and remain in suspension at the bottom

of the reactor without washing-out struvite crystals at the top (Figure 3). When they reach the desired size, the prills are harvested, dried in a fluidised bed and then screened and bagged to be sold as the slow-release fertilizer *Crystal Green*. This is available in a range of sizes from 90 to 450 SGN (9-45 mm average particle diameter) and contains 28% P<sub>2</sub>O<sub>5</sub>, 16.6% MgO and 5% N.

*Crystal Green* is reported to contain much lower levels of heavy metals, such as cadmium and lead, compared to conventional phosphate fertilizer products (Table 1). Wastewaters generally contain heavy metals in lower concentrations than mined phosphate and the struvite crystallisation process also tends to exclude impurities.

Ostara's Pearl reactors are available in three capacity sizes, the Pearl 500, Pearl 2000 and Pearl 10,000 struvite recovery units, capable of producing 0.5 to 10 t/d of fertilizer. The technology has been tested on a wide range of waste streams, including phosphogypsum pond water, phosphoric acid waste streams, manure digestates,

Table 1: Heavy metal concentrations in mined phosphate fertilizers compared to the recovered struvite product *Crystal Green*

Element	Concentration (mg/kg)			
	MAP	DAP	TSP	Crystal Green
Arsenic	7-30	10-23	13-16	0.39
Cadmium	0-172	3-35	5-96	0.24
Chromium	17	55-196	89	0.10
Lead	0-10	1-10	4-13	0.16
Molybdenum	5-20	3-20	11	0.21
Nickel	7-350	14-48	15-118	0.26
Zinc	10-3,010	50-386	61-1,296	1.60

Source: Britton & Abrary (2015)

corn ethanol thin stillage, food and drink effluents and municipal wastewaters. Economic viability generally requires a wastewater orthophosphate concentration above 75 mg/l and a soluble phosphorus loading of at least 50 kg/d.

### Phosphorus recovery at the world's largest water treatment works

Ostara has installed Pearl reactors at full-scale at eight locations globally in both North America and Europe. A further seven facilities are currently at the design and construction phase. Impressively, this includes an installation at the world's largest wastewater treatment plant in Chicago, Illinois. The Metropolitan Water Reclamation District of Greater Chicago (MWRD) selected Ostara and Black & Veatch to design and build a new nutrient recovery system at its 1,200

Mgal/d Stickney Water Reclamation Plant in 2013. The 413-acre plant serves 2.2 million people living within a 260 square mile area of Chicago and its surrounding suburbs, and is the largest facility of its kind globally.

Ostara and PCL Construction Management Inc are also building Canada's largest nutrient recovery facility at the Edmonton Waste Management Centre. A Pearl 10,000 struvite recovery unit will treat discharges from the Clover Bar settling lagoons at the centre's Gold Bar Wastewater Treatment Plant. The facility is expected to produce least 2,000 t/a of *Crystal Green* fertilizer when it becomes operational this year.

Ostara first piloted the Pearl process at Durham Advanced WWTP at Tigard in Portland, Oregon in mid-2007, and subsequently installed its first commercial-scale facility, a Pearl 2000 unit, at this 20 Mgal/d plant in spring 2009. Other Pearl

2000 units are in operation at sites across North America, including:

- The 50 Mgal/d F. Wayne Hill Water Reclamation Centre in Gwinnett County, Georgia
- The 40 Mgal/d Nine Springs WWTP in Madison, Wisconsin
- The 30 Mgal/d Rock Creek AWWTP in Hillsboro, Oregon
- The 20 Mgal/d Saskatoon WWTP in Saskatchewan, Canada

In Europe, another Pearl 2000 installation at the 15 Mgal/d Amersfoort WWTP in the Netherlands, operated by Waterschap Vallei & Veluwe, is due to enter operation in March 2016.

Smaller Pearl 500 units are installed in the US at the 20 Mgal/d York WWTP in Pennsylvania, and the 20 Mgal/d Nansmond WWTP in Suffolk, Virginia, and in the UK at Thames Water's 15 Mgal/d Slough sewage treatment works (STW).

## Recovery from wastewater streams

In urbanised countries, wastewaters are generally collected in municipal sewers and sent to centralised wastewater treatment plants (WWTPs) for purification before being released back into rivers and lakes. WWTPs produce large volumes of sewage sludge from the mechanical, biological and chemical treatment of wastewater. Around 90% of phosphorus entering WWTPs also ends up accumulating in this sludge.

The three main approaches to phosphorus recovery at a WWTP are **precipitation/crystallisation** from sludges or liquors, the **leaching/digestion of sludge solids**, and **sludge ash incineration** (Figure 4). Phosphorus can also be returned to agriculture through the direct application of dewatered, stabilised sludge to land, as is common in some EU countries such as the UK and France.

The objective of many current phosphorus recovery technologies is to capture P as the mineral struvite (NH<sub>4</sub>MgPO<sub>4</sub>·6H<sub>2</sub>O) and then market and sell this as slow-release fertilizer product containing plant-available N, P and Mg. Overuse of struvite can result in Mg saturation in soils, although this can be managed by selecting Mg-accumulating crops such as grains and legumes.

Struvite crystallization is the most readily-adoptable, commercial technology for P recovery currently. It is relatively simple, easy to scale-up and the number of full-size installations at water treatment and food and drink plants in Europe, North America and China is steadily growing. Advantageously, the struvite crystallisation process excludes heavy metals and generally delivers a regulatory-compliant fertilizer product with a negligible pathogen content and only traces of organic matter<sup>4</sup>.

Fig 4: Wastewater phosphorus recovery technologies

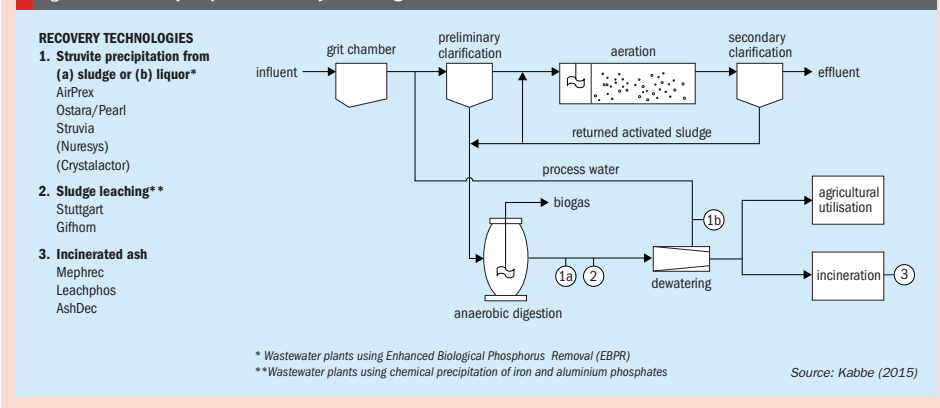

\* Wastewater plants using Enhanced Biological Phosphorus Removal (EBPR)  
 \*\* Wastewater plants using chemical precipitation of iron and aluminium phosphates

Source: Kabbe (2015)

CONTENTS

What's in issue 469

COVER FEATURE 1

Citrus fertilisation

COVER FEATURE 2

Pakistan's fertilizer industry

COVER FEATURE 3

Phosphorus recovery finally breaks through

FERTILIZER INTERNATIONAL  
**ISSUE 469**  
 NOVEMBER-DECEMBER 2015

**BCInsight**

Southbank House, Black Prince Road  
 London SE1 7SJ, England  
 Tel: +44 (0)20 7793 2567  
 Fax: +44 (0)20 7793 2577  
 Web: www.bcinsight.com  
 www.bcinsightsearch.com

Food and drink wastewaters

Netherlands-based **Paques BV** has developed the **PHOSPAQ** process for commercial P removal from wastewaters. The technology generally requires a P load of more than 100 kg/d and soluble P and N concentration of 50 mg/l and 200 mg/l, respectively. The process is suitable for effluents from anaerobic digesters, including upflow anaerobic sludge blanket (UASB) types, and has a quoted P removal efficiency of about 70-95%.

Similar to the **AirPrex** process, aeration within the **PHOSPAQ** reactor optimises the conditions for struvite formation by stripping carbon dioxide and raising pH to 8.2-8.3. The addition of MgO to the reactor precipitates P and NH<sub>4</sub> as struvite crystals (average size 0.7 mm) which are then captured by separators and harvested from the bottom of the reactor using a hydrocyclone and a screw press.

Paques' **PHOSPAQ** reactors are currently installed at around nine sites in Europe, North America and China, to treat food and drink effluents as well as WWTW wastewater (Figure 1). These include Severn Trent's Stoke Bardolph STW in the UK, and Waterstromen's Olburgen WWTW in the Netherlands.

The **NuReSys** struvite crystallisation process, developed by the Belgium company of the same name, treats industrial wastewater and WWTP liquors with a suspended solids content of up to 2%. Phosphorus recovery involves a two-stage process, in separate stripper and crystallisation reactors, and the addition of MgCl<sub>2</sub> and NaOH. At a pilot project in Amsterdam for Waternet, a **NuReSys** reactor reduced the P content of WWTP digestate from 375 mg/l to 14 mg/l.

To date, commercial installations of **NuReSys** have largely been at pharmaceutical and food and drink processing sites in

Belgium and Germany (Table 2). Return on investment of around 5-6 years is typical for the **NuReSys** technology, according to the company, assuming a 20 m<sup>3</sup>/h design throughput and a wastewater P concentration of 40-45 mg/l.

Other technologies poised to take off

The three main types of P recovery technology – struvite crystallisation, acid sludge leaching and incineration – were assessed and validated as part of the EU-funded P-REX project which ended in August (Table 3). Large engineering firms Outotec and Veolia were part of a 14-partner consortium behind the three-year long project, which also looked at the market potential and barriers for recovered phosphate products.

The economic viability of struvite crystallisation technologies, as proven by the growing number of full-scale installations globally, is directly due to the

Table 2: List of NuReSys phosphate recovery reactor installations

Plant operator	Treatment	Design flow (m <sup>3</sup> /h)	Inflow phosphate content (P, mg/l)	Outflow phosphate content effluent (P, mg/l)	Struvite production (kg/d)
Humana Milchunion eG, Germany	Dairy wastewaters	125	60-65	15-20	600
Clarebout Potatoes, Nieuwerke site, Belgium	Potato wastewater	120	150	20	100
Clarebout Potatoes, Warneton site, Belgium	Potato wastewater	80	115	15-20	1,200
Agristo NV, Belgium	Potato wastewater	60	100	15-20	600-800
Genzyme bvba, Geel, Belgium	Pharmaceutical	30	60	15-20	100

Source: NuSysRes

Table 3: Examples of the three main types of P recovery technology

Process	Developed by	Scale
<b>Struvite crystallisation from sludge and sludge liquor</b>		
<i>AirPrex</i>	PCS Pollution Control Service GmbH	Full-scale plants in operation
<i>Pearl</i>	Ostara Nutrient Recovery Technologies Inc	Full-scale plants in operation
<i>Struvia</i>	PCS Pollution Control Service GmbH	Pilot, 1,000 l/h
<b>Acid sludge leaching</b>		
Gifhorn	Seaborne Environmental Laboratory AG, Germany	Demonstration plant, 50,000 person equivalent
Stuttgart	ISWA, University of Stuttgart	Demonstration plant, 8,000 person equivalent
<b>Incinerated sewage sludge</b>		
<i>Mephrec</i> ash or dried sludge process	Ingitec, Germany	0.5 t/h planned pilot plant, Nürnberg, Germany
<i>LeachPhos</i> process	BHS Umweltservice GmbH, Switzerland	50 kg batch pilot plant
<i>AshDec</i>	Outotec, Finland and BAM, Germany	4 tonne pilot study

Source: EU P-REX project

Table 4: Performance of phosphorus recovery technologies

Technology	Product	P recovery*	Energy demand	Chemical demand	Comments
<b>Struvite precipitation from sludge and liquor</b>					
<b>AirPrex</b>	struvite (21% P <sub>2</sub> O <sub>5</sub> of DM)	7%	10 kWh/kg P	14.5 kg MgCl <sub>2</sub> /kg P	<ul style="list-style-type: none"> <li>Improves sludge dewatering.</li> <li>Prevents struvite clogging.</li> </ul>
<b>Pearl</b>	struvite (29% P <sub>2</sub> O <sub>5</sub> of DM)	12%	2.2 kWh/kg P 0.2 kg NaOH/kg P	3.1 kg MgCl <sub>2</sub> /kg P	<ul style="list-style-type: none"> <li>Prevents struvite clogging.</li> </ul>
<b>Sludge leaching</b>					
<b>Gifhorn</b>	struvite (28% P <sub>2</sub> O <sub>5</sub> of DM)	49%	7 kWh/kg P	8 kg H <sub>2</sub> SO <sub>4</sub> /kg P 0.2 kg Mg(OH) <sub>2</sub> /kg P 3 kg NaOH/kg P 0.8 kg Na <sub>2</sub> S/kg P	
<b>Stuttgart</b>	struvite (27% P <sub>2</sub> O <sub>5</sub> of DM)	45%	5 kWh/kg P	12 kg H <sub>2</sub> SO <sub>4</sub> /kg P 1.5 kg MgO/kg P 3 kg NaOH/kg P 4 kg C <sub>6</sub> H <sub>8</sub> O <sub>7</sub> /kg P	
<b>Ash incineration / thermal technologies</b>					
<b>Mephrec (for sludge inc. drying)</b>	slag with Ca-Si-PO <sub>4</sub> (10-25% P <sub>2</sub> O <sub>5</sub> )	80%**	12 kWh/kg P 22 kWh coke/kg P 68 kWh heat/kg P	2.7 kg coke/kg P 1.3 kg CaCO <sub>3</sub> /kg P	<ul style="list-style-type: none"> <li>Heat recovery potential: (&lt;55 kWh/kg P).</li> <li>High energy demand.</li> <li>Data based on simulation.</li> </ul>
<b>LeachPhos</b>	CaP or struvite (wet) 20-40% P <sub>2</sub> O <sub>5</sub> of DM	70%	1.6 kWh/kg P	5.6 kg H <sub>2</sub> SO <sub>4</sub> /kg P 0.6 kg NaOH/kg P 3.9 kg Ca(OH) <sub>2</sub> /kg P	<ul style="list-style-type: none"> <li>High waste stream</li> <li>Reprecipitation of toxic elements.</li> </ul>
<b>AshDec</b>	Ash with CaNaPO <sub>4</sub>	98%	0.8 kWh/kg P 3.5 kWh/kg P	3.3 kg Na <sub>2</sub> SO <sub>4</sub> /kg P 1.3 kg sludge/kg P	<ul style="list-style-type: none"> <li>High waste stream</li> <li>Only partly toxic element separation.</li> </ul>

\*As fraction of total P eliminated on WWTP. \*\*Assumed.

Source: EU P-REX project

performance benefits and operational savings they are able to offer – and their ability to deliver a high quality, saleable fertilizer product. These distinct advantages suggest that struvite crystallisation is the P recovery technology most able to compete economically with low-cost mined phosphate at present. In Europe, the investment cost for installing struvite crystallisation technology at WWTPs is thought to be around €0-3 per capita per year, a comparatively minor extra expense relative to the average annual cost of €40-120 per capita for wastewater treatment.

However, struvite crystallisation from sludge liquor is only able to capture a small fraction (7-12%) of the available P at WWTPs in comparison to other technologies. Much higher P recoveries, around 50% for sludge acid leaching and 70-90% for sludge incineration, are possible once the P bound in the solid phase of the sludge is also captured (Table 4).

According to some industry experts, investment should now focus on the full-scale demonstration of existing sludge leach-

ing and incineration technologies, as these offer the most promising and viable opportunities for improving P resource efficiency<sup>3</sup>. The “need to apply, demonstrate, and prove the more recent and innovative technologies to move these beyond their current infancy” was also recommended by a recent critical review of nutrient technologies<sup>4</sup>.

There are marked difference in the performance of various technologies currently at the pilot or demonstration plant phase, in terms of P recovery, product grade and energy and chemical demand (Table 4). For sludge leaching technologies, more chemicals and/or energy are typically consumed as phosphorus recovery rates increase.

Costs will need to be cut and process inputs (water, chemicals, energy) minimised for promising P recovery technologies to become commercially-viable. Operating cost reductions may also require the use of alternative, possibly waste-derived, sources of chemical raw materials in future.

Although still a long way off, there are predictions that the widespread adoption of

integrated N, P and K recovery technologies will ultimately lead to the creation of a high-value international market for recovered fertilizers. Such a development would allow food importers to begin returning nutrients, in the form of recovered fertilizers, to food exporting countries, partially reversing current national and regional nutrient imbalances. ■

References

1. Van Kauenbergh, S, 2010. *World Phosphate Rock Reserves and Resources*. IFDC.
2. Britton, A. & Abrary, P., 2015. Recovery of phosphate as struvite from wastewater streams. *International Fertilizer Society, Proceedings* 765.
3. Kabbe, C. et al., 2015. Review of promising methods for phosphorus recovery and recycling from wastewater. *International Fertilizer Society, Proceedings* 763.
4. Mehta, C. et al., 2015. Technologies to Recover Nutrients from Waste Streams: A Critical Review. *Critical Reviews in Environmental Science and Technology*, 45, 385-427.

CONTENTS

What's in issue 469

COVER FEATURE 1

Citrus fertilisation

COVER FEATURE 2

Pakistan's fertilizer industry

COVER FEATURE 3

Phosphorus recovery finally breaks through

FERTILIZER INTERNATIONAL  
ISSUE 469  
NOVEMBER-DECEMBER 2015

BCInsight

Southbank House, Black Prince Road  
London SE1 7SJ, England  
Tel: +44 (0)20 7793 2567  
Fax: +44 (0)20 7793 2577  
Web: www.bcinsight.com  
www.bcinsightsearch.com



# Massive FSU investments, falling costs

Three of the four large-scale greenfield potash projects likely to enter production globally in the next four to five years are located in the FSU. EuroChem's two Usolskiy and VolgaKaliy mining ventures and Belaruskali's Petrikov development form part of a potash capacity investment programme across the region running into tens of billions of dollars. We review the FSU potash investments of both incumbent majors and ambitious new market entrants.

The countries of the Former Soviet Union (FSU) are endowed with great potash wealth. As recently as 2013, FSU potash mining was described as one of several industries where Russia and her neighbours earn money by digging cash out of the ground. The change in commodity market conditions over the last two years may make this a boastful overstatement. But Russia's vast potash resources, both developed and undeveloped, still underpin its status as the second largest potash producer globally. Not to be outdone, neighbouring Belarus also benefits from ownership of the third largest potash resource in the world. Yet another sizeable potash deposit, found in parts of southern Uzbekistan and eastern Turkmenistan in Central Asia, adds to regional abundance.

## Potash powerhouse

With a total capacity of 25.3 million tonnes, the FSU region accounted for 29% of world potash capacity in 2014. This is projected to rise by almost a quarter (23%) over the next five years to reach 31.1 million tonnes by 2019, according to IFA's latest supply outlook<sup>1</sup>.

Much of the expected 5.8 million tonne medium-term increase will come

from Eurochem's Usolskiy and VolgaKaliy projects (4.7 million tonnes combined) in Russia supplemented by other projects in Belarus and Uzbekistan. Additional capacity is also being developed in Turkmenistan and Kazakhstan, but projects in both countries are not expected to start contributing to regional potash production until the

2020s. Looking further ahead, brownfield and greenfield projects will add 15.7 million tonnes to FSU capacity by 2025, according to a base-case scenario from analysts Integer Research (Figure 1). Production in Belarus and Russia reached record levels last year and IFA predicts that the two countries will also commission three of the world's four new greenfield potash mines over the next five years<sup>1</sup>. What also marks out the FSU as different is the ability of the region's financially-strong major producers to independently pursue their own greenfield projects, an ability few outside of Canada possess.

Some of the major geological risks associated with potash mining were brought home late last year by the flooding of Uralkali's Solikamsk-2 mine in Russia – an event which, at a stroke, removed close to 2.4 million tonnes of FSU production capacity.

## Summary of investments

FSU capacity has expanded significantly in recent years, a trend that will continue going forward. Belaruskali, for example, is set to develop the Petrikov potash deposits in Belarus, having completed brownfield investments at its Krasnoslobodsky and Berezovsky sites – and is also continuing with debottlenecking projects to unlock additional plant capacity. The Slavkali project, adjacent to Belaruskali's operations in Belarus, also now appears to be moving ahead.

Fig 1: FSU potash capacity developments, 2013-2025



Source: Integer

In Russia, Uralkali is implementing a \$5 billion expansion programme to increase its muriate of potash (MOP) capacity from just over 10 million tonnes currently to 14.4 million tonnes by 2020. The wide-ranging programme encompasses both capacity expansions and new mine construction. A further roll-out of MOP capacity to 17.2 million t/a is a possibility, if Uralkali proceeds with its post-2020 Polodovovsky project.

EuroChem is going even further than Uralkali by investing \$7 billion in its VolgaKaliy and Usolskiy greenfield mining ventures, both of which should start producing in late 2017/early 2018. Acron has also undertaken initial work on a two million t/a MOP mine in Russia, although this project is unlikely to be commissioned until the early 2020s.

Elsewhere in the FSU, Uzkimiyosanoat has built and is currently ramping-up a second 400,000 t/a capacity plant at Dehkanabad. Uzbekistan, supplementing the existing 200,000 t/a MOP operation brought on-stream in 2010. In Turkmenistan, Turkmenhimiya is constructing a 1.4 million t/a mine and processing plant at Garlyk with Belarusian help, although the project has experienced delays.

Cost comparisons for the above investments show that FSU brownfield projects typically have a much lower capital cost (\$ per tonne of installed capacity) than greenfield projects in the region (Figure 2), although the costs of brownfield expansion in the FSU also varies greatly.

## Uralkali invests \$5 billion

Uralkali was the world's fourth largest potash company in 2014, accounting for 14.2% of global capacity. Until the end of last year, its two mining complexes in Russia, one at Berezniki and the other at Solikamsk, provided a combined MOP capacity of 12.5 million t/a, but this capacity fell back 10.2 million t/a after calamitous flooding ended production at the Solikamsk-2 mine.

Uralkali sensibly decided to review its entire capacity development programme following the Solikamsk-2 incident in late 2014. It is now prioritising those projects able to increase total MOP capacity to 14.4 million tonnes by 2020, and has set an investment budget of RUB 300 billion (\$5.06 billion) to help achieve this goal. The main elements of Uralkali's revised investment plan are (Table 1):

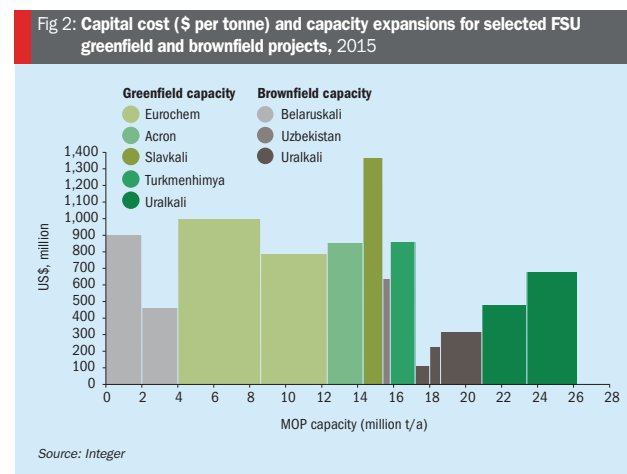

Table 1: Uralkali's potash capacity expansion plans, 2016-2020

Project	Project capacity* (million t/a)	Completion/ commissioning date	Capital cost (\$ per tonne)
Berezniki 3 + 4 – increasing load	0.8	2016	109
Solikamsk-3 expansion (phase 1)	0.6	2017	225
Solikamsk-2	2.3	2020	314
Ust-Yayvinsky	2.5*	2020	476
Polodovovsky	2.8	After 2020	680

\* Partially offset by capacity declines due to depletion

Source: Uralkali, Integer

- The construction of Ust-Yayvinsky mine and a new mine at Solikamsk-2
- A capacity expansion at Solikamsk-3 involving construction at shaft number 4
- Loading increases at Berezniki-3 and Berezniki-4
- The development of more granulation capacity

Uralkali's load capacity improvement project will increase the proportion of MOP recovered from mined ore and, by modernising and replacing equipment, capacity at Berezniki-3 and Berezniki-4 should rise by 0.8 million t/a before the end of 2016.

A new 0.6 million t/a production facility at Solikamsk-3 is due to be launched in 2017 following the completion of shaft 4. Improvements at the site include the installation of two hoist machines, a shaft extension to a depth of 481 metres, the building of a pit bottom paddock and loading complex, and the fitting of new conveyors.

The \$1.2 billion Ust-Yayvinsky mine, which commenced construction in 2012, is scheduled to produce its first ore from the Verkhnekamskoye deposit in 2020. The new mine is designed to replace the depleted two million t/a capacity Berezniki-2 mine. The completion of a 6.3 km belt conveyor to transport ore from Ust-Yayvinsky to Berezniki-3's processing plant will also increase annual MOP output at Berezniki-3 by 0.5 million tonnes.

Initial design engineering work for the new 2.8 million t/a Solikamsk-2 mine project should start this year. If all goes according to plan, the new mine will safely extract Solikamsk-2's remaining 86 million tonnes of potash reserves when it becomes operational in 2020. The \$1.9 billion Polodovovsky greenfield project, meanwhile, remains a possible option for Uralkali post-2020. The planned complex consists of a new 11 million t/a capacity mine and a 2.8 million t/a MOP flotation plant and granulation unit.

**EuroChem on track**

EuroChem's ambition is to become self-sufficient in potash and ultimately bring on-stream 8.3 million t/a of greenfield capacity. The firm has invested around \$2.4 billion to-date in developing two Russian potash mining projects to achieve this goal (Table 2, Figure 3), and is also weighing up whether to move into sulphate of potash (SOP) production (see accompanying interview, p52).

**VolgaKaliy (Gremyachinskoe)**

An underground mine to extract potash from the Gremyachinskoe deposit in Russia's Volgograd region is currently under construction as part of the VolgaKaliy project. Production from VolgaKaliy is expected to begin in early 2018 and ramp up to 2.3 million t/a of capacity as part of the project's first phase. A subsequent second phase of development will eventu-

ally increase capacity to 4.6 million t/a. With proven and probable reserves of 492 million tonnes, the mine is predicted to have a useful life of over 40 years. MOP produced by VolgaKaliy will be transported 500 kilometres by rail to EuroChem's Tuapse port on the Black Sea for onward shipment.

EuroChem is currently sinking a cage shaft and two skip shafts at VolgaKaliy to reach the 1,250 metre-deep potash layer. As of end-September, the cage shaft had reached a depth of 807 metres, and the two skip shafts extended 1,010 metres and 720 metres below ground level. The current Capex estimate for VolgaKaliy stand at \$4.6 billion, an apparent \$400 million fall on the 2014 estimate of \$5 billion.

**Usolskiy (Verkhnekamskoe)**

The Verkhnekamskoe deposit in Russia's Perm region is the location of the Usolskiy mine, EuroChem's other greenfield potash

project. The potash layer at Usolskiy is 500 metres-deep, less than half the depth of the Gremyachinskoe deposit at VolgaKaliy. The Usolskiy potash is of lower grade (30.8% KCl) and, at 420 million tonnes, has slightly less proven and probable reserves compared to VolgaKaliy's ore.

The 473-metre deep cage and skip shafts at Usolskiy were completed last year. The project remains on track to begin potash production in early 2018, as part of the first phase to develop a 2.3 million t/a capacity mine. An additional 1.4 million t/a of capacity will subsequently be phased-in by 2024 under current plans. With an expected useful mine life of more than 35 years, MOP from Usolskiy will be rail-freighted over a distance of 1,600 km to the Baltic port of Ust-Luga.

EuroChem is giving itself the option of further long-term expansion at Usolskiy. In June 2014, the company gained an additional exploration and production licence for

Fig 3: Schematic of Eurochem's Usolskiy and VolgaKaliy mine projects

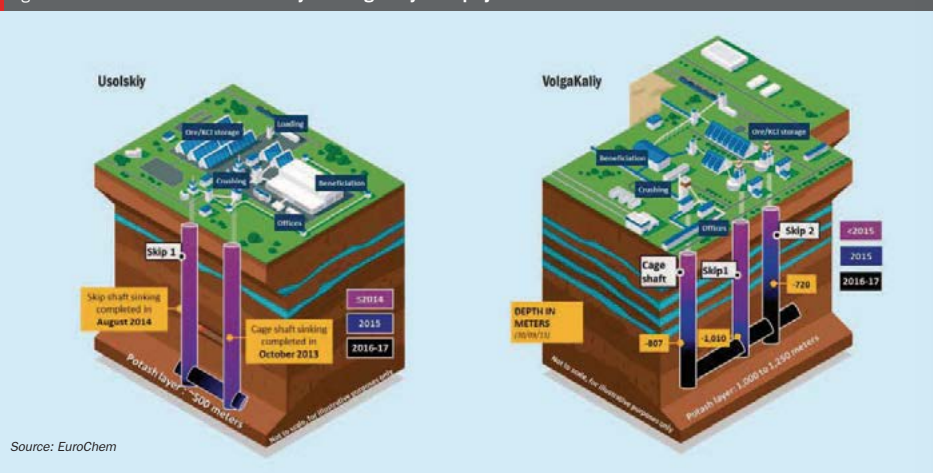

Source: EuroChem

Table 2: EuroChem's VolgaKaliy and Usolskiy projects

Location	Potash capacity ('000 t/a)	Capital cost (\$m)	Capital cost (\$ per t/a)	Proven & probable reserves size (million tonnes)	Grade (% KCl)	Status
<b>VolgaKaliy</b>						
Gremyachinskoe, Russia	4,600	4,600	1,000	492	39.5%	Under construction
<b>Usolskiy</b>						
Verkhnekamskoe, Perm, Russia	3,700	2,900	784	420	30%	Under construction

Source: EuroChem, Integer

Location	Potash capacity ('000 t/a)	Capital cost (\$ million)	Capital cost (\$ per tonne)	Measured & indicated resources (million tonnes)	Grade (% KCl)	Status
Talitsky, Perm, Russia	2,000*	1,700	850	709	36.9%	Pre-full construction

\*Potential further expansion to 2,600 t/a beyond 2023.

Source: Acron, Integer



Construction at EuroChem's Usolskiy project.

the Belopashinsky plot of the Verkhnekamskoe deposit, a 65 km<sup>2</sup> area immediately adjacent to the 123 km<sup>2</sup> Palashersky plot where the Usolskiy mine is sited. This additional plot increases accessible reserves at Verkhnekamskoe to about 2.3 billion tonnes, sufficient for a mine life of 60 years at MOP production of 3.7 million t/a, according to EuroChem.

**Acron aims for 2021 start-up**

Nine years ago, Acron set up the Verkhnekamsk Potash Company (VPC) to develop a mine at the Verkhnekamsk potassium-magnesium salt deposit in Perm Krai. Acron holds a 51% controlling share in VPC, the remainder being divided between a number of other investors. VPC subsequently won a license to develop the Talitsky area of the deposit in 2008, with preparatory construction work at the site finally commencing in 2012.

VPC's Talitsky mine has an ore mining design capacity of 7.45 million t/a and production capacity of two million t/a MOP (Table 3). Built-in extra capacity will allow VPC to boost plant MOP output by a further

0.6 million t/a, if required. Production at Talitsky is scheduled to commence in 2021 and then reach full design capacity by 2023. Approximately a quarter of the output will be consumed in-house for downstream NPK production and the rest will be marketed externally. Any falls in the rouble should be advantageous as more than half of the \$1.5-1.7 billion capex for the Talitsky project is rouble-pegged.

One advantage for Acron and VPC, in terms of capital outlay, is that the potash layer at Talitsky is relatively shallow and mining shafts will only have to be sunk to 350-400 metres to access the Verkhnekamsk ore. Approval of the mine design by Russian federal authorities in August, and the granting of a construction permit, now clears the way for Acron to move to full-scale construction.

**Large-scale greenfield project for Belarus**

Belaruskali was the world's third largest potash producer in 2014, its 12.7 million t/a capacity accounting for a 14.5% slice of the world total. Over the last six

years, Belaruskali has commissioned two new mines, Krasnoslobodsky mine in May 2009 and Berezovsky mine in June 2012, to expand capacity at its Soligorsk mining and processing complex and replace two pre-existing mines, Soligorsk 1 and Soligorsk 2, as their reserves become depleted. Potash ore from Berezovsky and Krasnoslobodsky mines is refined at the existing processing plants of Soligorsk 1 and Soligorsk 2 sites, respectively, enabling Belaruskali to keep the capital costs of production low.

Looking ahead, Belaruskali commenced work on its new, 1.5 million t/a MOP capacity Petrikov mining and processing project in 2013, having won a competitive tender to develop the Petrikov ore deposits of the Gomel region in 2011. The deposit occurs at a depth of 516-1,386 metres with ore reserves estimated at 236 million tonnes.

The Petrikov project is highly significant as it is one of just four large-scale greenfield potash projects due to be commissioned globally over the next four years, according to IFA<sup>1</sup>. Petrikov should begin producing towards the end of 2019 and increase Belaruskali's total MOP capacity to 14.7 million tonnes when it achieves full capacity. This total includes the extra 0.5 million t/a of capacity expected from debottlenecking projects across Belaruskali's operations over the next five years. Production at Petrikov could eventually expand to three million t/a later in the 2020s.

Also in Belarus, plans by the Slavkali project to produce two million t/a of MOP from the country's Starobin potash deposits are also firmly back on the agenda. The start of construction at the new mine was marked by a ceremony held in September. The part Chinese-funded project should start producing MOP around 2020 and is likely to ramp up to 1.1 million t/a of capacity by 2022. China will be the main market for the bulk of its sales.

Although the two companies are said to enjoy close links, the private sector Slavkali project will operate independently from state-owned giant Belaruskali. Slavkali will, however, trade its MOP through the

CONTENTS

What's in issue 469

COVER FEATURE 1

Citrus fertilisation

COVER FEATURE 2

Pakistan's fertilizer industry

COVER FEATURE 3

Phosphorus recovery finally breaks through

FERTILIZER INTERNATIONAL  
**ISSUE 469**  
NOVEMBER-DECEMBER 2015

**BCInsight**

Southbank House, Black Prince Road  
London SE1 7SJ, England  
Tel: +44 (0)20 7793 2567  
Fax: +44 (0)20 7793 2577  
Web: www.bcinsight.com  
www.bcinsightsearch.com

## EuroChem keeps to its game plan



EuroChem's mining division head and management board member, **Clark Bailey**, updates Fertilizer International on the group's major potash investments in Russia in an exclusive interview. Bailey confirms that progress at both Usolskiy and VolgaKaliy is "pretty much following our game plan right now".

### Usolskiy

EuroChem awarded a major construction contract for the beneficiation mill at Usolskiy in mid-2015, as Bailey explains.

"We settled on a Turkish company called Renaissance who'd done some work on big mills – one in Turkmenistan – and we're very happy as they've mobilised very quickly. Their proposed schedule matches up with our original plan to be finished with the mill so we can do cold commissioning at the end of 2017.

"We're going to do the first two trains and cold commissioning about September 2017, then going into hot commissioning in December 2017 right behind it. We'll have our ready to 'brine-up' as soon as the processing plant says they're ready to go.

"Usolskiy's going pretty well. We've spent over \$960 million to date and, percentage wise, completion is just under 40% [for both phases]. The mines aren't being touched right now as the shafts are already sunk and we are converting to permanent headframes."

### VolgaKaliy

Construction of VolgaKaliy is also almost midway through. But, unlike Usolskiy, its beneficiation mill is being built in-house by EuroChem's own company, NRSS.

"VolgaKaliy is in a similar situation, at 46% complete and about 52% spent [phases 1 & 2]. We have some advance payments on some of the big stuff at VolgaKaliy – that causes the mismatch there – although we always keep track and have bank guarantees for those advances," comments Bailey.

Summing up, he says: "Everything is advancing well. We've actually started the

basic engineering for the next phases at both mines, which is adding another 2.3 million tonnes at VolgaKaliy and another 1.4 million tonnes at Usolskiy. That work has started."

### Importance of the domestic market and downstream demand

Bailey is confident that the Russian domestic market will grow and accept more MOP by the time production ramps up towards 2020.

"Our sales and marketing people say that Russia has a huge upside. It is a big bread basket, but it's not being used as a bread basket yet. Much of the fertilizers are still going to India, China, Brazil. [But] sooner or later there's going to be a market here.

"Our first tonnes are going to go to ourselves, for our NPK blends in places like Antwerp and Nevinnomysk. [As a group] we already consume about half a million tonnes of KCl and will probably ramp-up to twice that amount by the time we've started up – which takes all of the first year's production. That takes us into 2019 and by then we will be spreading more regionally and internationally as both markets will also be expanding."

### Exports and a possible link up with Uralkali

Although not definitely ruling out some level of cooperation, Bailey questions whether a link-up with Uralkali on export sales makes sense.

"I don't think Uralkali and Belaruskali will come back together [as] Belaruskali now has a sales group – they don't need

Uralkali. I don't think we need Uralkali either, but does it make sense for us to work together? – I don't know.

"We haven't been marketing KCl ourselves but our team has the contacts. So that's not a hurdle for ourselves to worry about – we have a good sales team and an extensive global sales network."

### Plans to produce SOP

EuroChem has been looking at three to four options for producing SOP and is currently pursuing all of these.

"We're very interested in the SOP market as we think it's a very good complement to our KCl business. It's a small market but it could be larger. It's restricted because there's not that much SOP out there and it does get a better price tag – as it should since it is more difficult and costly to produce," confirms Bailey.

He adds: "Fruits, some vegetables, tobacco, every wine area, they all prefer SOP. So we're looking at all the options of how to move some of our K from MOP to SOP. There are a lot of people with an appetite for 2-3 times what the world is producing and they just can't get it."

### Risks and opportunities

Other producers are starting to acknowledge that EuroChem is going to realise its ambitions on potash, says Bailey: "The competitors have finally realised we're real – five years ago we weren't on anybody's radar."

He continues: "It's very capital intensive and it takes a huge amount of time, 7- to 9 or more years. Not a lot of people have that staying power but the shareholders decided [EuroChem was] going to be a complete [NPK] nutrient supplier in the market place, and had the patience and tenacity.

"The biggest worry everyone has is that the big producers, PotashCorp, Mosaic, Uralkali, Belaruskali, don't kill [the market] by overbuilding themselves trying to push others out. If a 60 million tonne market increases 2-4% a year that's another [potash] plant every year. That can't happen and isn't happening – so ultimately there's a bigger market than there is a supply."

Bailey concludes by saying: "Disciplined companies will not kill their market. A new company like us, we're coming in very slowly. We're not going to produce 4.6 million tonnes in the first year – it's impossible – we'll have a very slow ramp up." ■

Belarusian Potash Company (BPC), the body which handles all of Belaruskali's export volumes currently.

### Central Asia emerges

In Uzbekistan, Uzkimyosanoat completed an expansion project at its existing Dehkanabad potash plant last year. The site produced around 170,000 tonnes of MOP in January-August this year but is expected to ramp-up to full 600,000 t/a capacity by 2018. Uzbekistan has potash ore reserves of 200 billion tonnes with an average grade of 36.8% (KCl content). The same deposit extends over Uzbekistan's border, providing neighbouring Turkmenistan with another 400 million tonnes of ore reserves.

The Turkmenhimiya Garlyk potash mine in the Lebap region of Turkmenistan also started production over the summer. The 1.4 million tonne MOP mine and processing plant is expected to be fully commissioned early in 2017. With maximum domestic demand estimated at 700,000 tonnes, at least half of the mine's output is likely to be exported. India is a key target

market and the country's Prime Minister, Narendra Modi, discussed future fertilizer supply during a visit to Turkmenistan in June. The project is being implemented by Belarusian firm Belgorkhimprom under an agreement with the Turkmen government dating from 2010. A future link-up with BPC over export handling is thought possible, due to the close level of cooperation between the two countries.

### Fierce competition, low costs

Large capacity additions and a growing field of new entrants is likely to ratchet up competition, comments Lisa Smith, potash research manager at analysts Integer Research.

"I can only see competition on potash exports intensifying out of the FSU," says Smith. "Prior to August 2013 there was one channel exporting product from both Uralkali and Belaruskali, but these two producers have since gone it alone and soon will be joined by new entrants."

She adds: "Notwithstanding a possible tie-up with Uralkali on export sales, which has been mooted, EuroChem plans to add

over eight million tonnes of new potash capacity and this will of course not all go downstream. Belaruskali is still increasing its capacity and Slavkali is set to build next door, although likely to export through BPC. The 1.4 million t/a Turkmen project is also set to do the same. Acron's Russian project is also still in the offing."

The competitiveness of Russian producers continues to improve. Already low production costs have fallen further due to the rouble's recent decline.

"Russian production costs are the lowest in the world, with few companies able to produce at below \$100 per tonne – In fact, Uralkali's costs are significantly lower than this, averaging about \$56/t in recent years," comments Smith. "However, they fell to just \$47/t in 2014, due to depreciation of the rouble and higher production compared to 2013, and to \$33/t in the first half of this year." ■

### References

1. Prud'homme, M., 2015. Fertilizers and Raw Materials Global Supply 2015-2019. 83rd IFA Annual Conference, Istanbul, 25-27 May 2015

WE CONVEY QUALITY



SCHADE Stockyard Equipment for the Fertilizer Industry

**SCHADE**  
AUMUND GROUP

SCHADE Lagertechnik GmbH • Bruchstraße 1 • 45883 Gelsenkirchen • Germany  
sales@schade-lagertechnik.com • www.schade-lagertechnik.com

## CONTENTS

What's in issue 469

## COVER FEATURE 1

Citrus fertilisation

## COVER FEATURE 2

Pakistan's fertilizer industry

## COVER FEATURE 3

Phosphorus recovery finally breaks through

FERTILIZER INTERNATIONAL  
**ISSUE 469**  
NOVEMBER-DECEMBER 2015

**BCInsight**

Southbank House, Black Prince Road  
London SE1 7SJ, England

Tel: +44 (0)20 7793 2567

Fax: +44 (0)20 7793 2577

Web: www.bcinsight.com  
www.bcinsightsearch.com

## Advertisers' index

Advertiser	Page	Contact	Fax / Email
Aumund Holding BV	53	Ms Vera Lambrix	31 77 32 00 728
Buckmann International	Centre	Mr Keet J Lee	kjlee@buckmann.com
European Machine Trading	15	Mr Gustaaf Zeeman	31 224 591 454
Hebel Monband Water Soluble Fertilizer Co., Ltd	IFC	Ms Tracy Gao	tracygao@jtainy.com
Integer Research	19	www.integer-research.com	
Koch Agronomic Services	33/41	kascustomerservices@kochind.com Kochagronomic.com	1 866 863 5550
Köppern GmbH & Co. KG	39	Mr Stefan Bremer	s.bremer@koeppern.de
Ludman Industries	17	Mr James Lenahan	jlenahan@ludman.net
Neelam Aqua & Speciality Chem (P) Ltd	OBC	Mr Mithlesh Kumar Mathur	91 141-2460081
Prayon Technologies s.a.	42	Mr Marc Collin	mcollin@prayon.be
Stamicarbon	5	Mrs Mieke Beaujean	31 46 476 3792
The Sulphur Institute: Sulphur World Symposium 2016	IBC	www.sulphurinstitute.org/events	
Wolf Trax Inc	9	www.wolftrax.com	

Next issue: January/February 2016

Distribution at:

**AFA Annual Fertilizer Forum, Cairo, Egypt**

- **Fertilizers and viticulture** Healthy vine growth and high grape yields require the timely application of suitable fertilizers. We look at the vital contribution nutrients can make to successful commercial grape growing and winemaking.
- **The year ahead** What will 2016 have in store for the fertilizer sector? We weigh up the latest supply and demand forecasts and gauge industry opinion on prospects for the coming year.
- **Iran re-emerges** The lifting of sanctions will provide Iran with access to previously blocked export markets and could herald a revival of investment in its fertilizer industry. We assess the impact sanctions removal will have on Iranian production capabilities and the global trade in nitrogen and sulphur.
- **Clean and green nitrogen technologies** Carbon emissions from nitrogen production are edging ever closer to theoretical limits. We outline the technological options for further emissions reduction, including carbon capture and storage (CCS), renewable energy and biomass gasification.
- **Phosphates market review** Analysts have suggested that growing Indian demand, stalling Chinese production and the dollar's strength, as well as the rouble's weakness, will all impact on the phosphates market. We review recent changes in the supply, consumption and trade in phosphate products.
- **K+S strengthens its position** We profile K+S as it seeks to strengthen its competitive position by cutting costs and building a balanced market presence in Europe, South America and Asia. The company plans to expand into new sales regions and sell more high margin products in future.

Closing date for advertisement space booking is 11 January 2016

For further information and to book advertisement space contact:

Tina Firman, Publishing Director: [tina.firman@bcinsight.com](mailto:tina.firman@bcinsight.com)

Tel: +44 (0)20 7793 2567 Fax: +44 (0)20 7793 2577

Editor: SIMON INGLETHORPE  
[simon.inglethorpe@bcinsight.com](mailto:simon.inglethorpe@bcinsight.com)

Contributor:  
OLIVER HATFIELD  
[publications@integer-research.com](mailto:publications@integer-research.com)

Editorial Advisory Board:  
JOHN SINDEN, J S Associates  
PAUL SMITH, Consultant  
DR. NORMAN CHIEN, IFDC

Publishing Director: TINA FIRMAN  
[tina.firman@bcinsight.com](mailto:tina.firman@bcinsight.com)

Subscription rates:  
GBP 300; USD 550; EUR 450

Subscription claims:  
Claims for non receipt of issue must be made within 3 months of the issue publication date.

Subscriptions Manager / enquiries:  
MARIETTA BESCHORNER  
Tel +44 (0)20 7793 2569  
Fax +44 (0)20 7793 2577  
[marietta.beschorner@bcinsight.com](mailto:marietta.beschorner@bcinsight.com)  
Cheques payable to BCInsight Ltd

Advertising enquiries:  
TINA FIRMAN  
[tina.firman@bcinsight.com](mailto:tina.firman@bcinsight.com)  
Tel: +44 (0)20 7793 2567

Agents:  
Japan: (also subscription enquiries)  
KOICHI OGAWA  
O.T.O. Research Corporation  
Takeuchi Building  
1-34-12 Takadanobaba  
Shinjuku-Ku, Tokyo 169, Japan  
Tel: +81 3 3208 7821  
Fax: +81 3 3200 2889

Previous articles from *Fertilizer International* and *PK Insight* from 1997 to the present are available digitally in PDF format. To make a purchase, or for a list of available articles, please see:  
[www.bcinsight.com](http://www.bcinsight.com)

Copyright:  
Issued six times per year, or bi-monthly. All rights reserved. No part of this publication may be reproduced, stored in a retrieval system or transmitted in any form or by any means – electronic, mechanical, photocopying, recording or otherwise – without the prior written permission of the Copyright owner.  
ISSN: 0015-0304

Design and production:  
JOHN CREEK, DANI HART



Printed in England by:  
Buxton Press Ltd  
Palace Road, Buxton, Derbyshire,  
SK17 6AE

© 2015 – BCInsight Ltd

**BCInsight**

Published by: BCInsight Ltd  
Southbank House, Black Prince Road  
London SE1 7SJ, England  
Tel: +44 (0)20 7793 2567  
Fax: +44 (0)20 7793 2577  
Web: [www.bcinsight.com](http://www.bcinsight.com)  
[www.bcinsightsearch.com](http://www.bcinsightsearch.com)



THE SULPHUR INSTITUTE'S  
**SULPHUR WORLD  
SYMPOSIUM 2016**  
VANCOUVER, CANADA

**Register early  
and save!**

## The Sulphur Institute's Sulphur World Symposium 2016

April 11-13, 2016 | Vancouver, Canada

Now in its 10th year, the symposium brings together sulphur industry leaders for three days of education and networking events!

Tour one of Kinder Morgan's Canadian terminals! Exhibition booths, sponsorships and cultural tour opportunities are also available!

Visit the website for more information:

[www.SulphurInstitute.org/Symposium16](http://www.SulphurInstitute.org/Symposium16)

Enter "F1PSWS" to save US\$50 on your registration!

### Presentations include:

#### Global Phosphate Supply and Demand

Jeff Holzman, PotashCorp

#### Mosaic Sulphur Melter

Herman Wittje, The Mosaic Company  
Mark Gilbreath, Devco USA LLC

#### Global Sulphur / Sulphuric Acid Outlook

Meena Chauhan, Integer Research Ltd.

#### Global Economic Outlook

Prakash Loungani, International Monetary Fund

LEARN



NETWORK



SHOWCASE



CONTENTS

What's in issue 469

COVER FEATURE 1

Citrus fertilisation

COVER FEATURE 2

Pakistan's fertilizer industry

COVER FEATURE 3

Phosphorus recovery finally breaks through

FERTILIZER INTERNATIONAL  
**ISSUE 469**  
NOVEMBER-DECEMBER 2015

**BCInsight**

Southbank House, Black Prince Road  
London SE1 7SJ, England  
Tel: +44 (0)20 7793 2567  
Fax: +44 (0)20 7793 2577  
Web: [www.bcinsight.com](http://www.bcinsight.com)  
[www.bcinsightsearch.com](http://www.bcinsightsearch.com)

TSI THE SULPHUR INSTITUTE

+1 202 331 9660 TSISulphur

Events@SulphurInstitute.org

Sponsored by:

KINDER MORGAN

SAVAGE

Official Publication:

SULPHUR

Published by BCInsight

MARTIN SULFUR

Oxbow

sultran LTD.

Since 1980

# Increase Your PROFITS at no extra cost

**Fertilizer Quality Improvement Chemicals**  
ISO 9001 Certified, Worldwide Acceptance



ANTICAKING AGENT



COLOURING AGENT



HARDENING AGENT



ANTIFOAM FOR PHOSPHORIC ACID



MICRONUTRIENT/TRACE ELEMENT FIXER



DUST SUPPRESSOR



SLOW RELEASE OF N<sub>2</sub>



FLOCCULANT



DIATOMACEOUS EARTH / REACTIVE SILICA



FROTH FLOTATION AGENT



NEEM OIL



NEEM CAKE

Suitable for SSP, TSP, MAP, CAN, ANP, NPK, DAP, AN, AS, UREA & Other Fertilizers

Working all over the world to improve the quality of fertilizers

Tailor made products & Technical Services to suit Individual Factory's need.



## NEELAM AQUA & SPECIALITY CHEM (P) Ltd.

701, North Avenue, Road No. 9A, V.K.I. Area, Sikar Road, Jaipur-302013 (INDIA)

Ph. : +91-141-2333718 • Fax : +91-141-2333418 • Mobile : +91-9829069545

Email : mkmathur@neelamaqua.com, support@neelamaqua.com, www.neelamaqua.com

### Don't forget the next issue of Fertilizer International January/February 2016

CONTENTS

What's in issue 469

COVER FEATURE 1

Citrus fertilisation

COVER FEATURE 2

Pakistan's fertilizer industry

COVER FEATURE 3

Phosphorus recovery finally breaks through

FERTILIZER INTERNATIONAL  
**ISSUE 469**  
NOVEMBER-DECEMBER 2015

## BCInsight

Southbank House, Black Prince Road  
London SE1 7SJ, England

Tel: +44 (0)20 7793 2567

Fax: +44 (0)20 7793 2577

Web: www.bcinsight.com  
www.bcinsightsearch.com