

1
2
3
4
5
6
7
8
9
10
11
12
13
14
15
16
17
18
19
20
21
22
23
24
25
26
27
28
29
30
31
32
33

Welcome to our interactive version of **Sulphur** Issue 396

Please use either the buttons on the left or top right of the page to navigate your way around this interactive PDF

IMPORTANT INFORMATION:

Copyright – Issued six times per year, or bi-monthly. All rights reserved. No part of this publication may be reproduced, stored in a retrieval system or transmitted in any form or by any means – electronic, mechanical, photocopying, recording or otherwise – without the prior written permission of the Copyright owner.

Number 396

September | October 2021

SULPHUR

www.sulphurmagazine.com

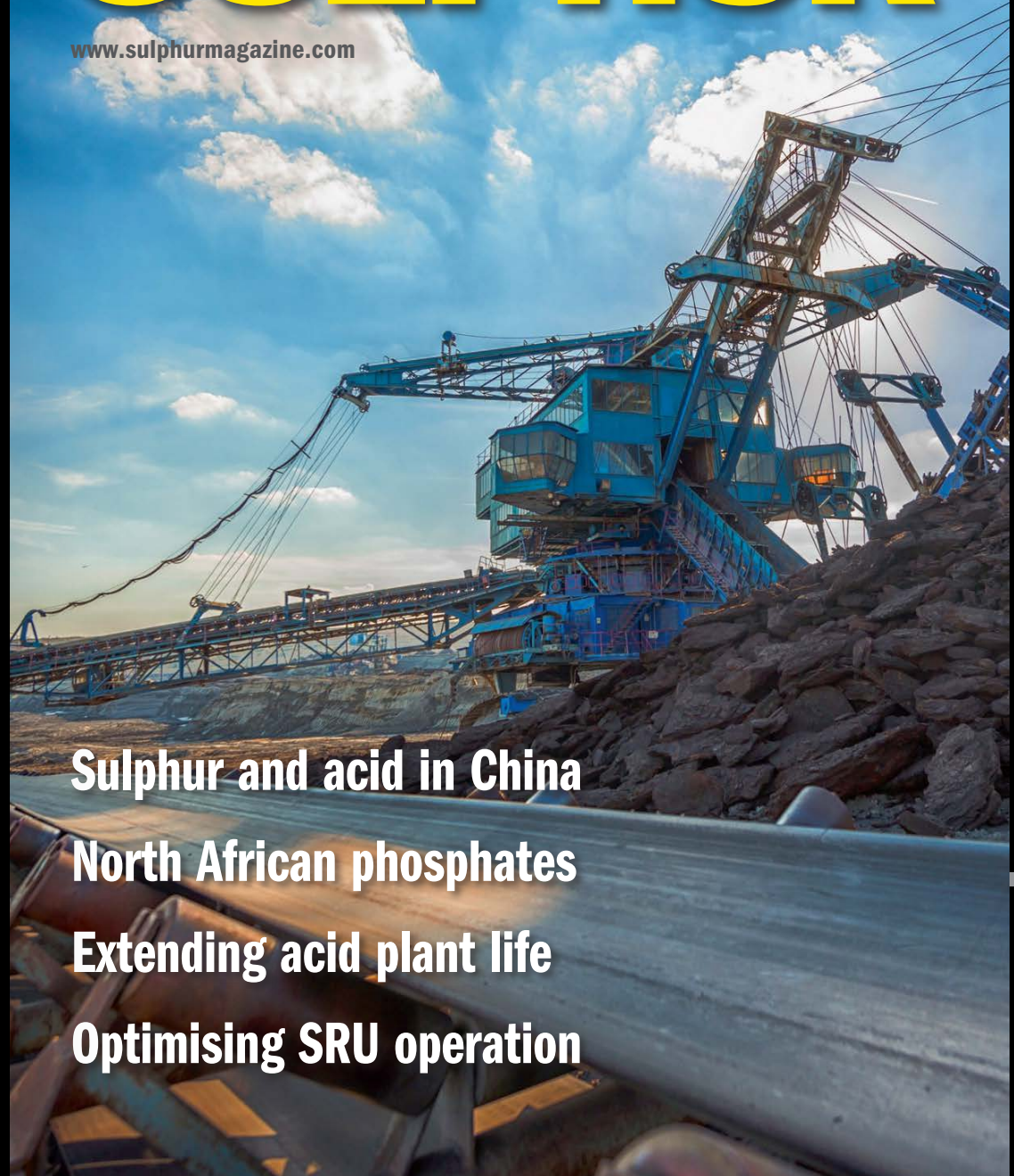

Sulphur and acid in China

North African phosphates

Extending acid plant life

Optimising SRU operation

CONTENTS

What's in issue 396

COVER FEATURE 1

Sulphur and acid in China

COVER FEATURE 2

North African phosphates

COVER FEATURE 3

Extending acid plant life

COVER FEATURE 4

Optimising SRU operation

SULPHUR
ISSUE 396
SEPTEMBER-OCTOBER 2021

BCInsight

Southbank House, Black Prince Road
London SE1 7SJ, England
Tel: +44 (0)20 7793 2567
Fax: +44 (0)20 7793 2577
Web: www.bcinsight.com
www.bcinsightsearch.com

We are everything sulphur and much more

Comprimo and Chemetics – delivering sulphur and sulphuric acid solutions for a more sustainable world.

Through everything we do, we provide maximum long-term profits for our customers while meeting the most stringent environmental requirements. Helping our customers to be better neighbours is always good business for them and us.



Decrease
OPEX



Reduce
emissions



Energy
efficiency

Learn more with one of our experts
email: sulphursolutions@worley.com

Comprimo[®]

worley.com/comprimo

CHEMETICS[®]

worley.com/chemetics



Cover: SvedOliver/Shutterstock.com



15

Sulphur supply chains

Principles for managing sulphur supply.



17

Extending acid plant life

A phased approach to keeping plants operational.

Read this issue online at:
www.sulphurmagazine.com

Published by:

BCInsight

SULPHUR

www.sulphurmagazine.com

NUMBER 396

SEPTEMBER | OCTOBER 2021

CONTENTS

10 China's sulphur and sulphuric acid industries

China is the world's largest importer of sulphur, mainly to feed domestic phosphate production. Sour gas in Sichuan and new refinery production, coupled with rationalisation in the phosphate sector are all leading to reduced imports, while new smelters are increasing sulphuric acid production and reducing the need for pyrite-based and sulphur burning acid production.

12 New North African phosphate plants

As well as Morocco, Egypt, Algeria and Tunisia all have major phosphate industries, and all of these countries have plans to expand their capability to extract and process phosphates, though Algeria and Tunisia remain hampered by political instability.

15 Sulphur supply chains: still mission critical in 2021

John M. Bryant, President and CEO of The Sulphur Institute, looks at how the sulphur supply chain has reacted to the extraordinary circumstances of the pandemic over the past 18 months, and the key principles of a successful sulphur supply chain.

16 Sulphur dust control

Dealing with sulphur dust is an operational challenge for sulphur forming plants and sulphur storage and handling facilities.

17 Extending the life of acid plants

Chemetics describes a variety of ways to extend the life of sulphuric acid plants. Debottlenecking, emissions reduction and/or energy recovery projects require a systematic, phased approach to maximise the potential of economic and operational benefits to the owner.

20 Drying out acid condensation

Corrosion is one of the most critical aspects regarding sulphuric acid plant lifespan. One important cause of corrosion in sulphuric acid plants is acid condensation from the process gas due to inadequate drying. Clark Solutions discusses this problem and how it can be avoided with proper tower and internals design.

22 The untapped potential of your sulphuric acid plant

DuPont Clean Technologies examines simple, tried, and true tactics, as well as new products and designs that can be incorporated into existing plants to address operating efficiency and emissions and to help prolong the life of sulphuric acid plants.

25 Digital tools to optimise the operation of your sulphur recovery unit

Comprimo has recently launched two new solutions to make the most of existing data and to improve customer's operations and customer knowhow: Comprimo Insight – an intelligent sulphur plant dashboard and Comprimo Immerse – a dynamic sulphur plant simulator.

29 Ammonium salt formation conditions based on measured vapour pressures

ASRL has studied ammonium salt formation and deposition downstream in the Claus plant. In this study, existing knowledge on thermal stability of ammonium salts and new measurements have been used to identify the gaseous components required for deposition, through reversible vapour pressure expressions.

REGULARS

- 3 Editorial Oil assets and 'net zero'
- 4 Price Trends
- 5 Market Outlook

- 6 Sulphur Industry News
- 7 Sulphuric Acid News
- 9 People/Calendar

CONTENTS

What's in issue 396

COVER FEATURE 1

Sulphur and acid in China

COVER FEATURE 2

North African phosphates

COVER FEATURE 3

Extending acid plant life

COVER FEATURE 4

Optimising SRU operation

SULPHUR
ISSUE 396
SEPTEMBER-OCTOBER 2021

BCInsight

Southbank House, Black Prince Road
London SE1 7SJ, England
Tel: +44 (0)20 7793 2567
Fax: +44 (0)20 7793 2577
Web: www.bcinsight.com
www.bcinsightsearch.com

Oil assets and 'net zero'



Mining giant BHP's decision this August to dispose of its oil and gas assets to Woodside Petroleum (see Industry News, page 11) in a deal estimated at \$29 billion is certainly eye-catching. But it is also part of a larger pattern of divestment of fossil fuel assets by oil and gas companies who have dominated the industry for decades. It follows divestment by investors, institutional and otherwise, as efforts to tackle climate change consistently point towards a future where we will be using gas, and especially oil, far less – indeed, where many are talking about achieving 'net zero' carbon emissions by the middle of the century or shortly thereafter.

Fossil fuel companies are by and large valued on their reserves, and if those reserves will not be exploited, then those assets become 'stranded', and the valuation must fall. The net worth of companies like ExxonMobil, Shell and BP are currently only around half that of their peak value a few years ago, and last year, Exxon was dropped from the Dow Index. ExxonMobil, Chevron, BP, Shell, Total and Eni have between them sold \$28 billion in assets since 2018, and are targeting further disposals of more than \$30 billion. Industry-wide, Wood Mackenzie puts the value of oil and gas assets for sale at \$140 billion. In April this year, seven European countries, including France, Germany, and the United Kingdom, announced that they would halt public funding for certain fossil fuel projects abroad, and Norway's sovereign wealth fund – itself largely garnered from the country's oil and gas royalties – last year said cashed out of positions in major mining and energy companies. Ireland said in 2018 it would divest totally from fossil fuels.

Under those circumstances, BHP's decision to get out of that business and focus upon mining potash for fertilizer instead might look prudent, although paradoxically, its share price actually fell after the announcement. But of course, there are two sides to every deal, and one group's disposal is another's acquisition. Woodside said that it sees the BHP acquisition as increasing economies of scale and options for their LNG assets. Other companies have also been looking for bargains. Ineos Energy has also been deliberately buying unwanted fossil fuel assets; in March picking up Hess Corporation's oil and gas assets in Denmark for \$150 million, in spite of the Danish government stating that it intends to end all oil production by 2050.

And all of this disguises the fact that oil and gas production, and with it sulphur output, has steadily

moved from the control of western 'majors' over the preceding decades towards national oil companies (NOCs). Publicly listed energy majors now account for only 12% of the world's oil and gas reserves, 15% of production and 10% of estimated carbon emissions from industry operations, according to the International Energy Authority. The assets remain, but they are increasingly in the hands of NOCs, many of whom have not made any commitment to reduce emissions, or at least which have far less ambitious targets to do so than publicly traded companies. It is a shell game. Some argue that the focus on supply is putting the cart before the horse – selling an oil field does not reduce oil-related emissions if demand for oil globally remains unchanged. In order to meet climate goals, we will need to reduce oil demand.

Even so, the lack of investment money available for oil and gas projects is already becoming problematic in places such as Africa, where governments complain of 'climate imperialism' as money to fund e.g. LNG projects which would bring much needed development cash starts to become more difficult. It is easier, they argue, for western nations, where only an average of 2% of GDP comes from natural resources, to move out of fossil fuels, than African countries where the figure averages 25%. Innovation and technical know-how in the sector has also traditionally come from the majors, such as with shale gas production, which has changed the industry, while expertise with sour gas production gained in Europe and North America has been an invaluable component of more recent sour gas exploitation in the Middle East, Central Asia and China.

Investor activism and fossil fuel divestment is changing the way that the oil and gas majors operate, but to have any meaningful impact upon emissions and climate, a more globally-based, joined-up strategy is needed, and that can only come from governments. ■

Richard Hands, Editor

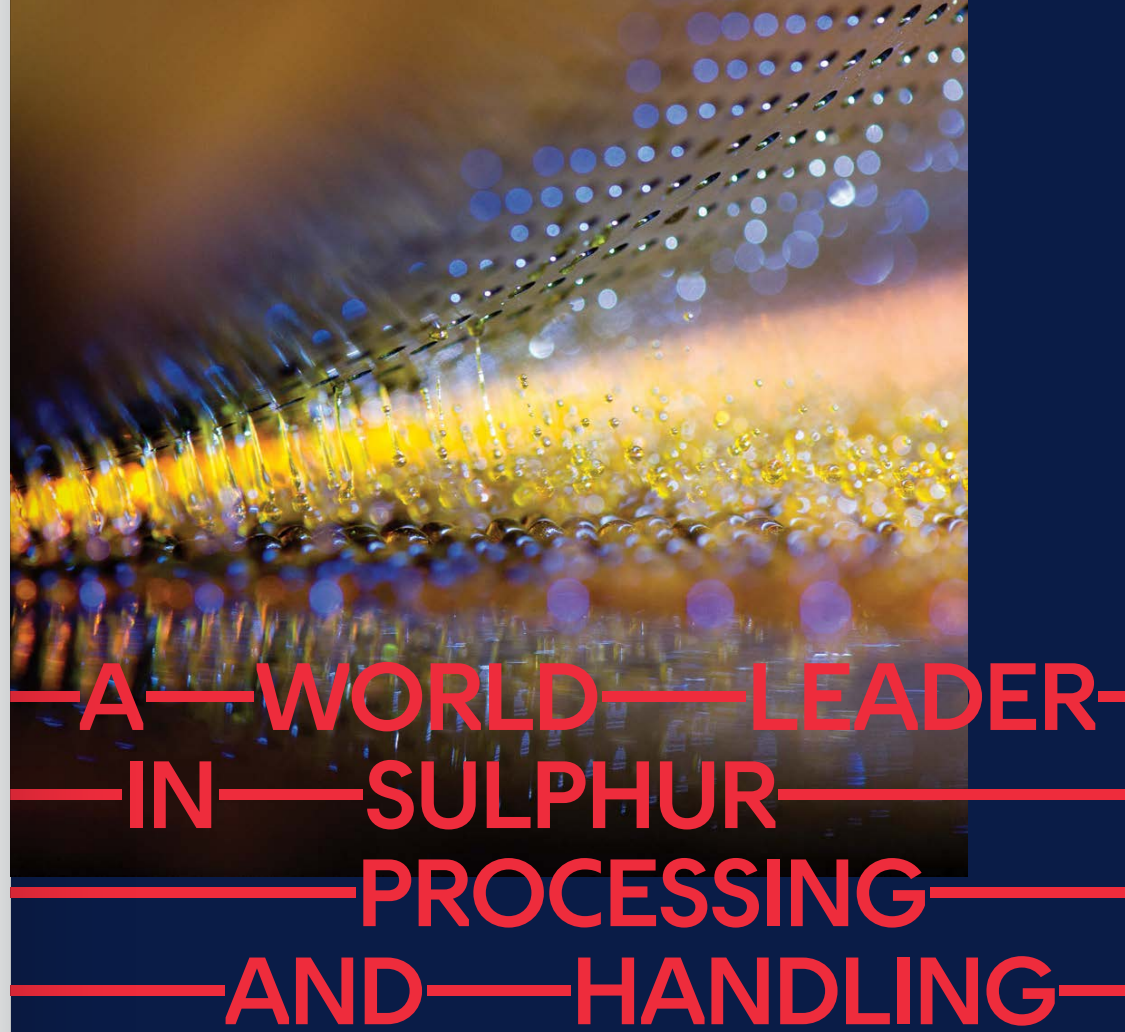

End-to-end systems from receipt of molten sulphur to loading of solid material – single source supply by IPCO.

- Premium Rotoform pastillation.
- Duplex steel belts specifically alloyed to resist corrosion.
- High capacity drum granulation.
- Downstream storage – silo and open/closed stockpiles.
- Custom-built reclaimers for any location.
- Truck, rail and ship loading and bagging systems.
- Large scale block pouring.

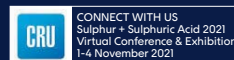

CONTENTS

What's in issue 396

COVER FEATURE 1

Sulphur and acid in China

COVER FEATURE 2

North African phosphates

COVER FEATURE 3

Extending acid plant life

COVER FEATURE 4

Optimising SRU operation

SULPHUR
ISSUE 396
SEPTEMBER-OCTOBER 2021

BCInsight

Southbank House, Black Prince Road
London SE1 7SJ, England
Tel: +44 (0)20 7793 2567
Fax: +44 (0)20 7793 2577
Web: www.bcinsight.com
www.bcinsightsearch.com



MARKET INSIGHT

Meena Chauhan, Head of Sulphur and Sulphuric Acid Research, Argus Media, assesses price trends and the market outlook for sulphur.

SULPHUR

Following third quarter contract settlements, liquidity in the global sulphur market has been limited, with prices in the spot market stabilising. The impact of the global pandemic appears to have waned in recent months as most regions are progressing with vaccine rollouts. Escalating case rates in India earlier in the year had been a cause for concern, but this has diminished with regular business resuming. Demand for DAP for the Indian market is expected to be a supportive factor for the coming months with remaining tonnes required for the karif season. The country has yet to secure around 3 million tonnes of DAP required to fill demand for the fertilizer year to March 2022. Firm DAP prices have deterred purchases, with sulphur imports expected to produce phosphoric acid to help meet demand. The price premium for sulphuric acid remains unworkable for the majority of processed phosphates producers in the country. Indian sulphuric acid prices have firmed by 260% since the start of the year to end August at \$168/t c.fr at the time of writing. In comparison, sulphur prices were at \$213/t c.fr at end August, an increase of 86% over the same period.

Over in China, buying activity has been slow, with the domestic fertilizer season resuming in the fourth quarter. Molten sulphur prices firmed through July/August at the low end, closing the gap with the solid prices. Demand from the domestic market is expected to remain healthy through the remainder of the year. Export demand for DAP/MAP is also supporting the sulphur

outlook, with strong demand from South Asia. Port inventories of sulphur at the major ports fell to below 2 million tonnes to 1.64 million t in mid-August, leading to an uptick in domestic prices. The drop in inventories and higher local prices may lead to an uplift in import prices, but with rising domestic capacity and supply, low inventories may become a more regular occurrence. Across 2021 and 2022 Argus forecasts over 2 million tonnes of additional capacity will be brought online. While several projects are expected to ramp up in the short term, there is some uncertainty emerging in the Chinese refining sector. The government has cut refiners' export quotas for the second half of the year. Just 7.5 million t of oil products will be warranted for export, a drop of 75% from the last announcement in December 2020. State and independent refiners have been impacted, leading to uncertainty around how quickly new supply will grow.

Sulphur supply out of the Middle East has been improving as operating rates continue to tick up on the back of rising fuel demand, leading to softening in pricing. Muntajat/ Qatar and KPC/Kuwait dropped prices for August to \$166-166/t f.o.b. from the mid-\$170s/t f.o.b. in July. Meanwhile in the UAE Adnoc rolled over its July price for August at \$175/t f.o.b., for shipments to the Indian market. This led to some uncertainty in the market on price direction. Average prices in August 2021 for spot were \$175/t f.o.b. in the region, up \$76/t on prices at the start of the year. But the benchmark has dropped by around \$12/t on average since the peak

in the second quarter. The firmer domestic Chinese market was also reflected in the bid levels under the Qatari sales tender for 35,000 t for September loading, with an award believed to have been made at just above \$180/t f.o.b. Expectations are for prices to remain stable in the short term, but there are mixed views on the outlook. Renewed interest from the Chinese market could push up pricing, but increased availability of supply may put some downward pressure on achievable prices.

OPEC+ has provided clarity on extra supply expected in the market following a period of tightness. An additional 400,000 bbl/d per month will be reintroduced through to April 2022 and a further 432,000 bbl/d through to September 2022. This supports the view for softer sulphur prices in 2022, with a price correction expected after firming this year.

On the projects side in the Middle East, formal start up of Kuwait's KNPC Clean Fuels Project (CFP) is still awaited following the commissioning of various units at the project earlier in the year. Sulphur capacity in the country will increase to above 2.0 million t/a once the refineries reach capacity.

In Indonesia, new nickel high-pressure acid leaching (HPAL) projects continue to support sulphur imports from the Middle East. HPAL Lygend is the first nickel project using this technology in the country with sulphur consumption estimated at over 300,000 t/a at capacity in the medium term. Other nickel projects are in development are forecast to further ramp up demand for sulphur in the country, supporting trade and pricing. One of the questions in the market has been how and if the development of several smelters with associated sulphuric acid supply would impact sulphur imports in the outlook but we do not expect the sulphur burner projects to be impacted.

SULPHURIC ACID

Global sulphuric acid prices have yet to reach a ceiling in August, with major benchmarks gaining ground over the past quarter. The contrast with sulphur has been stark – during a period where prices eased for several weeks in July-August. This is a reflection of the continued tightness in the smelter acid market balance, with numerous outages – both planned and unplanned – leading to disruption to supply. Argus estimates over 2 million t/a of acid losses in 2021 from turnarounds. The market bulls outweigh the bears in the view for the remainder of the year. The year ahead is more opaque, with the potential for a downward correction – led by an expected downturn in sulphur and processed phosphates prices. But the tightness in smelter acid is not expected to ease significantly early in 2022, pointing to the potential for further disconnect between sulphur and sulphuric acid market pricing.

Average monthly acid prices for NW European export volumes have firmed by over 400% since the start of the year, compounded by heightened demand from the domestic market, including the UK and strong demand from major markets in external regions. The average price for the month in mid-August was assessed at \$172/t f.o.b. for spot. As Europe accelerates its energy transition plans to a low-carbon economy, demand for battery metals is expected to rise, and this has drawn investment to develop assets in the continent. In Finland, ramp up at Terrafame's new battery chemicals plant started in June 2021 and

will increase the end user's sulphuric acid requirement. Consumption is also expected to rise in the UK and Germany in the outlook, with the water treatment and other industrial end uses driving the market. This will lead to an increase in the import requirement in the UK following the closure of the Inovyn sulphuric acid plant earlier this year. For Germany, we would expect to see exports dropping as domestic demand grows.

The outlook for Latin American acid consumption in the copper sector is in question with recent political developments. In Peru, Pedro Castillo won a 6 June run-off election and has veered left with his first cabinet. On paper, the Peru Libre party espouses nationalization of extractive industries. Increased sulphuric acid consumption is expected from the ramp up of the Mina Justa mine and, further in the forecast, the long-delayed Tia Maria copper project.

In the US, there are several copper projects in development in Arizona. Excelsior Mining's Gunnison project continues to progress. Merchant acid is currently being procured for the project but a sulphur burner is planned in the long term. Freeport McMoRan's Lone Star project has been exceeding the initial design capacity following start up in 2020. EPC activities have been advancing at Taseko Mines' Florence project, which was 60% complete in the second quarter. Initial deposits were being prepared for major processing equipment for the SX-EW plant in July. A key permit is expected by the end of the third quarter which will be followed by a public comment period. Meanwhile, acid demand for the lithium sector in Nevada has the potential to rise

substantially in the long term outlook. While projects are at early stages, at least one is likely to progress to a construction phase in the short term. Acid demand would be met by sulphur burners, expected to be constructed at each of the projects in development and would impact sulphur trade.

Average acid prices at SE US were assessed at \$225/t c.fr in August, an increase of around \$152/t on the start of the year, or a 208% increase. The benchmark firmed on the back of fundamentals driving global markets, with domestic supply constrained on the back of maintenance turnarounds and outages while demand has stayed strong.

PVS Chemical Solutions announced it will construct a new ultra-pure sulphuric acid plant in addition to its existing plants in Buffalo, New York and Houston, Texas, to meet increased demand for high-purity acid from the computer chip industry. Preliminary engineering has begun and the expectation is for production to commence in 2023.

Members of the United Steelworkers (USW) at Vale's Sudbury, Canada, nickel operations approved a new five-year collective bargaining agreement at the start of August, ending a two month strike. This will lead to a return of sulphuric acid production to regular levels. The strike squeezed the domestic acid balance, in an already tight market, contributing to a firmer footing in prices. While the resolution of the labour dispute is positive for acid supply, strong demand is expected to keep the market tight and prices are expected to remain elevated in the short term. ■

Price Indications

Table 1: Recent sulphur prices, major markets

Cash equivalent	March	April	May	June	July
Sulphur, bulk (\$/t)					
Adnoc monthly contract	157	157	189	184	175
China c.fr spot	223	230	233	249	256
Liquid sulphur (\$/t)					
Tampa f.o.b. contract	96	192	192	192	195
NW Europe c.fr	190	228	228	228	228
Sulphuric acid (\$/t)					
US Gulf spot	135	160	160	160	190

Source: various

Fig. 1: Global sulphuric acid demand for phos acid (year-on-year growth)

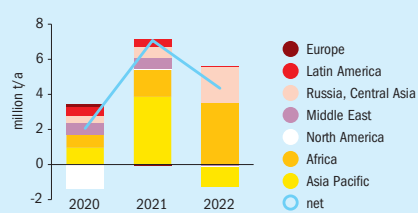

Source: Argus Sulphuric Acid Analytics

Fig. 2: Short term sulphur price forecast

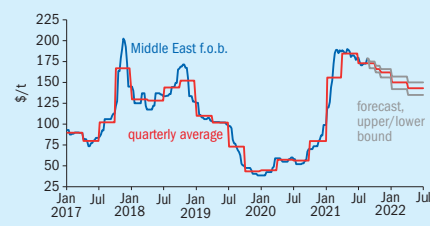

Source: Argus Sulphur Outlook

Market Outlook

Historical price trends \$/tonne

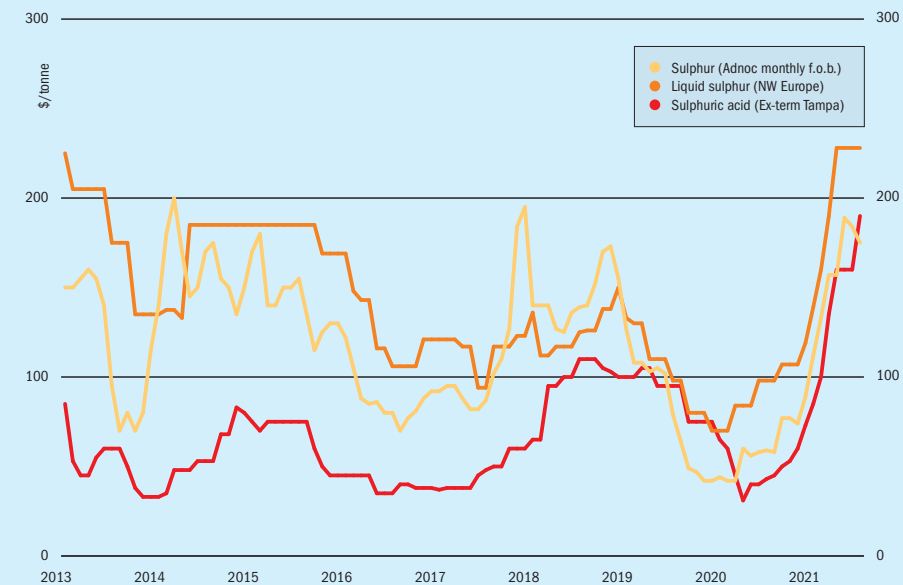

Source: BCInsight

SULPHUR

- The processed phosphates market view is supporting sulphur demand. The average DAP price for Morocco f.o.b. is forecast to rise significantly on 2020 levels. As the leading end use for sulphur consumption and trade, this has implications for pricing. The expected downward correction in DAP in 2022 will likely lead to a parallel decline in sulphur, at a time when supply is expected to improve in the oil and gas sector, adding further pressure for prices to ease.
- Large scale capacity additions have been delayed in the Middle East but remain a bearish factor for the short to mid term view. Kuwait and Qatar have projects with combined capacity exceeding 3 million t/a. Elsewhere, Saudi Arabia is also expected to ramp up sulphur supply from its gas and new refinery projects.
- US export duties on Moroccan phosphates products have not impacted OCP/Morocco and the producer has shifted any lost sales to Latin American markets where netbacks have been

high, limiting any production losses and keeping sulphur demand firm.

- **Outlook:** Prices are expected in the fourth quarter on the back of improving supply following the OPEC+ announcement as well as increased fuel oil demand as the impact of the global pandemic starts to wane. Freight rates appeared to steady in mid-August, but nonetheless remained elevated.

SULPHURIC ACID

- Copper prices eased in August on the back of mixed inflation signals and a stronger US dollar. Nickel prices picked up pace in June and July, largely supported by Chinese battery and electric vehicle demand. EV sales hit new highs in July and will continue to drive demand across copper and nickel. These investments in metals projects support the view for sulphuric acid consumption. Nickel and copper-based acid demand combined is forecast to rise by over 3 million t/a in 2021 on 2020 levels.
- Global sulphuric acid demand is forecast to grow by over 15 million t/a

in 2021, after a steep drop last year owing to the global pandemic. This is supportive for acid trade and pricing.

- Phase 1 start-up of the Udokan copper project is expected in the second half of 2022. Construction at the mine has been continuing with work underway on the concentrator and leaching site. An official announcement is still pending on whether acid demand will be met captive capacity from a sulphur burner or procured in the market. Argus expects the more likely scenario would be a sulphur burner.
- **Outlook:** Global acid prices are expected to remain firm in the coming months, marketing a continuation of the disconnect with elemental sulphur market pricing. The tightness in the acid market has not abated with the 2021 balanced expected to remain in deficit. A downward correction may emerge next year, based on the assumption balance returns but there is a risk to this moving to deficit once again as turnarounds and outages emerge. Average NW European acid prices are forecast at \$127/t f.o.b. for the year.



Building on its latest acquisitions, Axens Group offers a broader range of solutions that enhances the profitability and environmental performance of its clients. www.axens.net

Axens
Powering integrated solutions

CONTENTS

What's in issue 396

COVER FEATURE 1

Sulphur and acid in China

COVER FEATURE 2

North African phosphates

COVER FEATURE 3

Extending acid plant life

COVER FEATURE 4

Optimising SRU operation

SULPHUR
ISSUE 396
SEPTEMBER-OCTOBER 2021

BCInsight

Southbank House, Black Prince Road
London SE1 7SJ, England
Tel: +44 (0)20 7793 2567
Fax: +44 (0)20 7793 2577
Web: www.bcinsight.com
www.bcinsightsearch.com

INDIA

India discussing green hydrogen mandate for refiners

India's power and renewable energy minister RK Singh has placed draft plans before the cabinet for the country's refining and fertilizer sectors to switch to renewable 'green' hydrogen feeds. Other energy intensive sectors such as steel and transport are likely to follow. The policy suggests that refiners must have 10% of their hydrogen consumption generated from renewable electricity by the end of financial year 2023-24, rising to 25% by 2030. The comparable figures for ammonia/urea production are 5% and 20%, respectively. India is pursuing some of the world's most ambitious renewable energy targets of 175 GW of renewable energy capacity by the end of 2022 and 450 GW by 2030.

State-owned refiner IOC says that it will build its first commercial green hydrogen plant at the 160,000 bbl/d Mathura refinery in north India, using electricity generated from wind energy in Rajasthan to electrolyse water. The company also says that for the 500,000 bbl/d of new refining capacity that it plans to add by 2024 at its existing Panipat, Barauni and Nagapattinam refineries, it will use clean energy to run operations instead of fossil fuels such as fuel oil, naphtha or natural gas.

Reliance Industries has also announced investments totalling \$10 billion over the next three years to build plants that will produce green hydrogen and other forms of clean energy. ■

New sulphur unloader for Paradeep

Bruks Siwertell has won a contract to deliver a second screw-type ship unloader to Paradeep Phosphates Ltd (PPL), operating at the port of Paradeep, in Odisha state. The new Siwertell 640 D-type ship unloader joins a similar unit which has been serving the company since 2006. Owned by the Adventz Group and Morocco's OCP, PPL is a major manufacturer of phosphate fertilizers and is Asia's second largest producer of diammonium phosphate (DAP).

"We are delighted that PPL has once again turned to our technology," said Pierre Öhrwall, Sales Manager, South Asia, Bruks Siwertell. "In 2005, the operator was looking for a new ship unloader. After a visit to Australia to appraise a Siwertell installation there, PPL was convinced that a continuous, screw-type Siwertell ship unloader was the answer to its needs as it gives faster turnaround time and is environmentally friendly."

Similar to its predecessor, the new rail-mounted ST 640-D unit has the capacity to discharge sulphur from vessels up to 60,000 dwt in size, at a rated capacity of 1,500 t/h. It will alternate handling this cargo with rock phosphate at a rate of 1,200 t/h and potassium chloride (MoP) at 1,050 t/h. Both units are also fitted with the Siwertell Sulphur Safety System (4S), which was first developed over 30 years ago to minimise the risk of explosions.

"The flammable and explosive nature of sulphur, which is not so much of a problem in open systems using grab cranes, becomes an issue for enclosed systems," Öhrwall explained. "But sulphur handling should be contained and dust-free as it is damaging to the environment. Uniquely, Siwertell technology is able to offer totally enclosed screw-type unloading with systems equipped with the 4S."

It allows enclosed sulphur handling with any risk to personnel, equipment, vessel and port reduced to the minimum possible levels."

The new unloader will be delivered to the port in component parts and assembled on site. It is scheduled for operation at the end of 2022.

CANADA

New sulphur enhanced urea plant

Northern Nutrients has begun construction of a new sulphur enhanced urea fertilizer manufacturing facility outside of Saskatoon, Saskatchewan, with completion due early in 2022. The facility will use Shell Thiagro technology, a patented process for the incorporation of micronised elemental sulphur into urea, resulting in a sulphur form that is available to plants across the growing season, as part of Northern Nutrients' long-term strategy to bring sustainable fertilizer technologies to western Canadian farmers.

Matt Owens of Emerge Ag Solutions and co-owner of Northern Nutrients said, "We first tried the sulphur product three years ago, and all our growers who have tried it have increased their acres and moved all of their sulphur requirements over to the Shell micronised sulphur urea product. They like the product (11-0-0-75) because it is readily available to the plant early and throughout the growing season, it mixes well in any dry blend, and it has a low salt index compared to other forms of sulphur."

CHINA

Hydrocracker completes test runs

Axens says that its new 45,000 bbl/d H-Oil-based hydrocracker has completed performance guarantees at the Sinopec Zhenhai Refinery and Chemicals Company,

demonstrating vacuum residue conversion in excess of 80%. The implementation of the technology was coupled with existing assets such as delayed coking and fluidized catalytic cracking (FCC) units to maximise refinery performance. The unit was also able to adjust its operation to follow market opportunities to produce low sulphur bunker fuel from unconverted residue product.

"Axens and ZRCC have a long standing relationship and we are very proud of the conclusion of the H-Oil unit implementation. We are particularly impressed by the way Sinopec ZRCC operation teams have adopted this ebullated bed VR conversion technology and explored many of its flexibilities to address today's market uncertainties" said Jacques Rault, Conversion and Clean Fuels Director at Axens.

SOUTH AFRICA

Natref faces sale or closure

Sasol and its joint venture partner Total say that they are considering selling or closing their 107,000 bbl/d Natref refinery at Sasolburg. The firms have concluded that making the refinery compliant with the country's pending Clean Fuel 2 regulations, equivalent to Euro-V (<10 ppm sulphur) would not be financially viable, because current margins do not justify the investment required. South Africa currently operates on much more forgiving Euro-II (<500 ppm) sulphur standards.

Sasol and Total are reportedly exploring options such as converting Natref into a storage and blending facility to supply Sasol's facility at Secunda, which Sasol intends to convert to green hydrogen use to produce sustainable aviation fuels by 2030. The other options would be a sale or closure of the facility. Sasol expects to make a decision on Natref in the next few months.

UNITED STATES

New sour gas and carbon capture facility

Piñon Midstream LLC has begun construction on its new greenfield Dark Horse sour gas treating and carbon capture facility, with associated pipeline infrastructure, in Lea County, New Mexico. The project includes a centralised amine treating facility, an 18,000' (5.4 km) deep acid gas sequestration well, and 30,000 horsepower of compression, and is expandable to treat up to 400 million cubic feet of sour gas per day. The Piñon plant is designed to gather and treat natural gas containing any concentration of H₂S and CO₂, with the ability to deliver treated sweet gas to multiple third-party gas processing plants.

The Dark Horse facility and its associated pipelines are the first purpose-built sour gas infrastructure solutions of their kind in the Delaware Basin. A second amine treating plant is scheduled to be installed and operational in the fourth quarter, increasing Piñon's total sour gas treating capacity to approximately 170 million cubic feet per day.

MALAYSIA

Contract awarded for sour gas, CCS development

Petronas has awarded the conceptual engineering design contract for its offshore Kasawari carbon capture and storage (CCS) project to Norwegian energy consultancy Xodus. Kasawari off the coast of Sarawak, is a strategic project underpinning Petronas' commitment to achieve net zero carbon emissions by 2050 while also supporting the future supply of feedstock

for the production of liquefied natural gas.

Phase 1 of the project will tap a large sour gas field in Block SK 316 with estimated recoverable reserves of 3.2 tcf. It is due to come onstream in 2023, producing up to 900 million scf/d once production reaches capacity, and will use Honeywell UOP acid gas removal technology, including MemGuard and Separex technologies. Gas at Kasawari contains around 150 ppm of hydrogen sulphide, as well as up to 20% CO₂.

The second phase will begin capture and processing of carbon dioxide from the sour gas field development, which will then be injected into a nearby depleted gas field. Petronas plans to commence the first injection of CO₂ by the end of 2025, eventually reducing CO₂ emissions by 3.7 million t/a.

UNITED ARAB EMIRATES

Revised FEED contract for Hail/Ghasha

The Abu Dhabi National Oil Company (ADNOC) has initiated the bidding process for a revised front-end engineering and design (FEED) contract to optimise its huge \$15 billion Hail and Ghasha offshore sour gas developments. Pre-qualified bidders are understood to include Fluor, KBR, Technip and Wood Group. ADNOC is looking to 1.5 bcf per day of sour gas production from the project at capacity. EPC bidding began in 2019, with technical bids for the EPC packages submitted by November. However, further progress on the project was put on hold by the Covid pandemic and resultant fall in oil and gas prices. In September 2020 ADNOC reportedly began trying to reduce the scope of work on the project to reduce capital expenditure, and revised EPC bids were submitted in February this year. However,

the company is said to be considering "major changes" to key aspects of the project.

AUSTRALIA

BHP to exit oil and gas

BHP Group has announced a major strategic change of direction, exiting the fossil fuel business and moving instead towards what it describes as "future facing" commodities such as potash and nickel mining. It says that it will sell its oil and gas operations to Woodside Petroleum Ltd in exchange for shares that it will distribute to its own investors. The company has also approved \$5.7 billion of spending to build a massive new potash mine at Jansen in Canada, expected to start production in 2027, and has said that it will unify its dual-listed structure and shift to a single primary listing in Australia.

"Potash provides BHP with increased leverage to key global mega-trends, including rising population, changing diets, decarbonisation and improving environmental stewardship," the company said.

TURKEY

New sulphur recovery unit

Turkish construction group Tekfen Insaat and partner HMB Hallesche Mitteldeutsche Bau AG have been awarded the EPC contract for the construction of a new sulphur recovery unit at the Kirikkale refinery by operator Tupras. Tupras' upgrade plans for its four refineries include new sulphur units at its three main refineries, Izmit, Izmir and Kirikkale. Tekfen said that the project would take 36 months to complete, at a cost of \$54 million. ■



Watch free fertilizer market presentations

Argus deliver concise and insightful webinars analysing the nitrogen, phosphate, potash, sulphur and sulphuric acid markets. The webinars are offered on-demand and live – and are completely free to watch.

Watch the free webinars here:
www.argusmedia.com/webinars



SPAIN

INEOS completes sale of its Sulphur Chemicals business

INEOS Enterprises has announced the completion of the sale of its Sulphur Chemicals business to International Chemical Investors Group, for an undisclosed sum. INEOS Sulphur Chemicals business is Spain's largest dedicated manufacturer of sulphuric acid and oleum, serving clients in both agriculture and chemical intermediates via its 400,000 t/a plant in Bilbao. The business will become part of WeylChem's advanced intermediates and reagents portfolio, which includes an existing sulphuric acid and oleum plant located in Lamotte, northern France. WeylChem is wholly owned by the International Chemical Investors Group (ICIG).

"I am very pleased to have completed the sale of the INEOS Sulphur Chemicals business, which now becomes part of a

strategic business unit within International Chemical Investors Group," said Ashley Reed CEO INEOS Enterprises. "The business is an attractive addition to WeylChem's advanced intermediates and reagents portfolio that will help secure future development and growth, to meet customer needs in Europe."

Dr Uwe Brunk CEO WeylChem Group of Companies states "This acquisition underlines our commitment to bolstering our position as a strategic partner in advanced intermediates and reagents. INEOS Sulphur Chemicals and our French operations at WeylChem Lamotte complement each other perfectly. This combined business will be an agile, customer-focused player with superior services and supply certainty provided to demanding customers across Europe." ■

INDONESIA

Metso Outotec to license copper smelter, acid plant

Metso Outotec says that it has signed a major engineering and technology contract as well as licence agreements for the delivery of a copper smelter complex for PT Freeport Indonesia at Manyar near Gresik, East Java. Earlier in July a \$2.7 billion engineering, procurement and construction contract was signed with Chiyoda's Indonesian subsidiary. Metso Outotec says that it will receive €360 million (\$424 million) for its work on the smelter, which is based on licensed flash smelting, flash converting and Lurec® technology. It includes the design and supply of key process equipment and process control systems for the main areas of the smelter complex, the copper electrolytic refinery, the gas cleaning and sulphuric acid plants, slag concentrator and effluent treatment plant. Metso Outotec had previously conducted a front end engineering design study for the smelter. The smelter will handle up to 2.0 million t/a of copper concentrate, mainly from Freeport's huge Grasberg mine, making it the largest copper processing site in the world, according to PT Freeport. Commissioning is due for 2024.

Freeport is pressing ahead with the smelter on its own after negotiations about a joint venture with Chinese steel and nickel company Tsingshan Holding broke down earlier in the year. Freeport Indonesia will finance the smelter project by debt which, according to the shareholders agreement, will be shared 51% by Indo-

nesian state-owned mining firm Inalum and 49% by Freeport-McMoRan.

Pekka Vauramo, president and CEO of Metso Outotec, said: "Our joint efforts with Freeport Indonesia and Chiyoda will set a new standard for the copper smelter industry in fulfilling the strictest international environmental standards and efficiency requirements. We are very happy to work together to implement this game changing copper smelter." ■

WORLD

Price hike for sulphuric acid catalysts

Haldor Topsoe has announced an increase of prices for its VK sulphuric acid catalysts by €0.25 per litre. The company says that the increase has been driven by a "substantial increase" in the price of vanadium, which is a key raw material for sulphuric acid catalyst manufacture. DuPont Clean Technologies has likewise announced a global price increase of \$0.30/litre for its MECS® sulphuric acid catalyst products. Both price rises were effective immediately from their announcement in early August.

GERMANY

Acid plant up and running

Fibre manufacturer Lenzing Group says that it has successfully completed and commissioned an air purification and sulphur recovery plant at its Lenzing facility. The company invested €40 million in this project since construction began in 2019. The facility takes H₂S-rich CS₂ exhaust gases from the viscose manufacturing process and converts it to SO₂ and then sulphuric acid. The company says that it will allow

carbon dioxide emissions from the site to be reduced by 40,000 t/a and will also make the group more self-sufficient in securing vital raw materials for processing, which will bolster the site's competitive standing in terms of sustainability.

"As a result of this investment, Lenzing has made further progress towards implementing its climate targets, while achieving much greater autonomy with regard to one of its core raw materials", says Christian Skillich, Member of the Managing Board at Lenzing Group.

INDIA

Foundation stone laid for new acid plant

The chief minister of Odisha state Naveen Patnaik laid the foundation stone of a new 2,000 t/d sulphuric acid plant for the Indian Farmers Fertilizer Cooperative (IFFCO) at the company's Paradip site, in a ceremony on July 24th. The project, which is budgeted to cost \$54 million, is scheduled for completion in 2023. IFFCO says that the new acid plant, the third at the site, will reduce its dependence on imports of acid, as well as providing energy from waste heat to reduce the burden on the power generation sector, contribute to climate change initiatives by reducing carbon emission and greenhouse gases, generate employment and contribute to overall economic development.

New phosphoric acid plant for GSFC?

According to local press reports, Gujarat State Fertilizers and Chemicals (GSFC) is planning to set up a new phosphoric acid plant. V.D. Nanavaty, the company's chief

financial officer (CFO) and executive director of finance, told CNBC-TV18 that "we are thinking of putting up a phosphoric acid plant with a capex of around 1,500-2,000 crore rupees (\$200-270 million)." The company reported good earnings for 2Q 2021, with its industrial products showing highest growth.

CANADA

Nickel drives strong results for Sherritt

Sherritt International has reported improved earnings for its 2Q and 1H 2021 results on the back of strong nickel and cobalt production, as well as the receipt of \$28 million in distributions from the Moa high pressure acid leach joint venture in Cuba. Speaking at an earnings conference, Leon Binedell, president and CEO of Sherritt International said that adjusted EBITDA for 2Q 2021 was C\$18 million, up 114% from last year due to strong production totals at the Moa Joint Venture and improved nickel and cobalt prices.

Mixed sulphides production at the Moa JV in Q2 2021 was 4,020 tonnes, down 7% from 4,323 tonnes produced in Q2

2020. The decline was primarily due to reduced availability of sulphur on account of shipment delays to Moa. Lower mixed sulphides production was offset by the availability of high feed inventory levels at the refinery in Fort Saskatchewan, Alberta. Mixed sulphides production levels returned to normal in the latter part of Q2 with completion of acid plant repairs and improved sulphur availability at Moa.

EGYPT

Evergrow to use stock offering to finance new fertilizer complex

Egyptian fertilizer company Evergrow says that it intends to offer up to 70% of its shares on the open market in an IPO in 2023, as part of a financial restructuring plan, according to vice chairman Ahmed Khalifa. The company had previously discussed 30% or 40% stock offers and a \$400 million loan facility from a consortium of local banks. The company will become a holding company with six subsidiaries.

Evergrow is currently constructing a fertilizer complex at Sadat City, 95 km

from Cairo, in three phases, which are due to be complete by 2022-23, at a total cost of \$1.5 billion. Planned production includes 110,000 t/a of dicalcium phosphate capacity for animal feed, 90,000 t/a of calcium chloride capacity, 100,000 t/a of single superphosphate capacity, as well as calcium nitrate and NPK fertilizer plants. The complex will also include a 40,000 t/a phosphoric acid plant and a 200,000 t/a sulphuric acid plant. The site is being developed in a joint venture with Belgium's EcoPhos.

NORWAY

Boliden to expand zinc smelter

Swedish mining company Boliden says that it plans to invest €700 million (\$827 million) in an expansion of its Odda zinc smelter in western Norway, increasing the facility's capacity by 75% to 350,000 t/a. New facilities to be added include a new roaster, a new sulphuric acid plant, expansion and modernisation of the leaching and purification plants, and expansion of the foundry and quay infrastructure.

STEULER Surface Protection | Linings

THE ACID PROOF BRICK
NOW AVAILABLE IN US-SIZES

Protection against extremes is what our bricks stand for more than 111 years – worldwide.
No breakage on pallets to be calculated - just order the amount you need for a direct, safe and binding delivery!
What other challenges can we solve for you? Please reach out to us and we will find the right lining system for any kind of specification.

Directly from our warehouse in Houston, Texas - Just call us - We deliver!

STEULER-KCH GmbH
Phone: (713) 405-3545 | theacidproofbrick@steuler.com www.theacidproofbrick.com

CONTENTS

What's in issue 396

COVER FEATURE 1

Sulphur and acid in China

COVER FEATURE 2

North African phosphates

COVER FEATURE 3

Extending acid plant life

COVER FEATURE 4

Optimising SRU operation

SULPHUR
ISSUE 396
SEPTEMBER-OCTOBER 2021

BCInsight

Southbank House, Black Prince Road
London SE1 7SJ, England
Tel: +44 (0)20 7793 2567
Fax: +44 (0)20 7793 2577
Web: www.bcinsight.com
www.bcinsightsearch.com



The Sierra de Salitre phosphate project.

Boliden says that the expansion will be powered using hydroelectricity, and that waste will be processed in “using unique, sustainable technology”. As well as zinc, the smelter will also extract lead, gold and silver. The expansion project due to be completed by 2024. Boliden currently produces 1.7 million t/a of sulphuric acid from its facilities at Rönnskär, Harjavälta, Kokkola and Odda, of which Odda represents current production of 127,000 t/a by acid from an annual zinc output of 200,000 t/a. The new expansion would thus lift acid production by just under 100,000 t/a to around 225,000 t/a at Odda.

BRAZIL

Eurochem to buy phosphate project

Russian fertilizer producer Eurochem has signed an agreement to purchase Yara's Serra do Salitre phosphates project in Brazil. The project, sited in the southeastern Minas Gerais state, comprises a 1.0 million t/a mixed phosphates plant, producing mono ammonium phosphate (MAP), nitrophosphate, single superphosphate (SSP) and triplesuperphosphate. It is due to come on-stream in 2023, reaching capacity during 2024. The project also includes 1.2 million t/a of phosphate rock mining capacity. The mine and associated beneficiation plant are already operating, and currently producing around 500-600,000 t/a of phosphate rock. The project will also include a sulphuric acid plant, a phosphoric acid plant and a 400,000 tonne storage facility for finished fertilizers.

Eurochem will purchase the project through a shares purchase with a cash

consideration of \$410 million. Yara says that it expects that the transaction will be completed in six months, subject to regulatory approval. Yara had in turn taken full ownership of the project, work on which began in 2014, via its purchase of the remaining 40% stake in Galvani Industria, Comercio e Servicos in October 2018.

SERBIA

Rio Tinto looking to lithium

With increasing demand for lithium for batteries, Anglo-Australian mining company Rio Tinto says that it has committed funding for a \$2.4 billion lithium and borate project at Jadar in Serbia. Borates are used in solar panels and wind turbines. Rio Tinto says that it hopes to start construction of the mine in 2022, assuming that all permits are granted, with saleable production commencing in 2026 and full capacity being reached by 2029. Targeted output is 58,000 t/a of lithium carbonate, 160,000 t/a of boric acid and 255,000 t/a of sodium sulphate. Rio Tinto says it would be the largest producer of lithium in Europe for at least 10 years, producing enough for 1 million electric vehicles. Extraction of lithium from jadarite ore would require approximately 1,000 t/d of sulphuric acid.

UNITED STATES

Florida looking to close Piney Point

Florida governor Ron DeSantis has announced that he is directing the Florida Department of Environmental Protection (FDEP) to put together plans to perma-

nently close the Piney Point site. FDEP is currently suing site owner HRK Holdings after 215 million gallons of contaminated water were released into Tampa Bay in March and April this year when a pond holding waste water began to leak – the water was pumped out of the pond at FDEP's direction to avoid the collapse of the retaining wall. However, FDEP alleges that HRK, itself currently in bankruptcy proceedings, failed to meet a February 2019 deadline to create a plan for removing hazardous materials from the site. Piney Point was a phosphate production site owned variously by Borden Chemical, Royster Phosphates and finally Mulberry Phosphates, which went bankrupt in 2001. The site passed to FDEP, but was bought by HRK in 2006 intending to lease parts of the property to other industrial users, while taking responsibility for long-term maintenance of the gypsum stacks and ponds. However, HRK has been in Chapter 11 bankruptcy protection since 2012.

CHILE

Strikes threatens copper output

Copper prices worldwide began rising after workers at the Escondida copper mine, the largest in the world, began strike action following the breakdown of mediation talks between BHP Group and the Suplant union on August 10th. The Industrial Union of Labour Integration and the Unified Union of Workers also began strike action at facilities owned by state mining company Codelco and JX Nippon Copper's Case-rones mine after the collapse of last-ditch talks over a collective labour contract. High copper prices have increased union demands for better pay and conditions.

BHP finally reached a deal with Suplant's Andina division on August 18th, but talks are still pending at a number of mines including includes Codelco's El Teniente, El Salvador and Ministro Hales mines, BHP's Cerro Colorado, Anglo American's El Soldado and KGHM's Sierra Gorda.

DENMARK

FLSmith to buy thyssenkrupp's mining business

FLSmith A/S and thyssenkrupp AG have reached an agreement whereby FLSmith will acquire thyssenkrupp's mining business. Completion of the transaction is

expected in the second half of 2022 subject to regulatory approval. FLSmith says that thyssenkrupp's range of solutions for mining systems, mineral processing, material handling and services are “highly complementary” to its own offering. The combined company will be able to offer a complete pit-to-plant range of technology, equipment and service expertise, as well as digital solutions, covering continuous mining, mineral processing, mining systems and material handling.

Thomas Schulz, Group CEO of FLSmith, said: “The thyssenkrupp mining business and FLSmith are a perfect match, and I am proud to announce this agreement to join forces. This is a truly transformational deal allowing us to accelerate our growth ambitions by creating one of the world's largest and strongest suppliers to the mining industry. This acquisition will offer a strong value proposition for our customers, and there is a significant opportunity in transforming thyssenkrupp's mining business towards FLSmith's business mix and model with more than 50% service business. I look forward to welcoming the talented staff of thyssenkrupp's Mining business to our organisation.”

Martina Merz, Group CEO of thyssenkrupp AG, said: “FLSmith is an excellent owner and a very good new home for our mining activities. Both companies have a strong cultural fit and are a good match: the business models are comparable; the technologies complement each other well. The result is a world-leading technology provider from pit to plant. This is also a great opportunity for our employees. The merged new company will be able to drive innovation and digitalisation even faster and will increasingly focus on sustainability and ways to reduce environmental footprint.”

JAPAN

Sumitomo to double high purity acid capacity

Sumitomo Chemical says that it has decided to expand its production capacity for high-purity chemicals for semiconductors at its Ehime site at Nihama. To accomplish this, it will install new production lines to double the capacity for high-purity sulphuric acid at the plant, as well as increasing capacity for high-purity ammonia water at the Dongwoo Fine-Chem Iksan plant in South Korea, by approximately 40%. The new sulphuric acid pro-

duction line is due to commence operation in the first half of fiscal 2024, according to Sumitomo.

Sumitomo Chemical began the production of sulphuric and nitric acid for semiconductors at its Chiba Works in Japan in 1978, and production of high-purity sulphuric acid at Ehime commenced in 1991. Today the company engages in this business in Japan, South Korea, and China. High-purity chemicals used in the semiconductor production process, mainly for precision cleaning, are manufactured by using ultra-high purification technology

to reduce impurities down to a parts-per-trillion level in order to prevent foreign materials such as metal and organic impurities from affecting both quality and yield of semiconductors.

The semiconductor device market has continued to grow, driven by demand for 5G smartphones and increased demand for personal computers and data centre-related equipment. Against this backdrop, demand for high-purity chemicals, which are essential to the semiconductor production process, is expected to continue to increase strongly. ■

Connect with us during Sulphur + Sulphuric Acid 2021

Save energy. Save fuel. Save money.

You know Vectorwall improves efficiency and production of your Sulfur Recover Unit (SRU) or Spent Acid Burner, but did you know it can help with your Tail Gas CleanUp Unit (TGCU) and your Thermal Oxidizer (TOX)?

With the mixing and temperature benefits, you can expect:

- substantial energy and fuel savings translating into real dollars
- turn your units into high efficiency reactors with a simple interlocking wall and no moving parts
- improve harmonics and alleviate vibration issues

Contact Tim Connors, Senior Market Manager-Energy & Chemicals at tconnors@blaschceramics.com or by phone at 518-436-1263 ext 105, to learn how a Vectorwall improves your TGCU or TOX processes.

Blasch Precision Ceramics | 580 Broadway | Albany, NY 12204
518-436-1263 | www.blaschceramics.com

CONTENTS

What's in issue 396

COVER FEATURE 1

Sulphur and acid in China

COVER FEATURE 2

North African phosphates

COVER FEATURE 3

Extending acid plant life

COVER FEATURE 4

Optimising SRU operation

SULPHUR
ISSUE 396
SEPTEMBER-OCTOBER 2021

BCInsight

Southbank House, Black Prince Road
London SE1 7SJ, England
Tel: +44 (0)20 7793 2567
Fax: +44 (0)20 7793 2577
Web: www.bcinsight.com
www.bcinsightsearch.com

People



Connor Dyck, new chairman of the board at TSI.

The Sulphur Institute (TSI) has announced that **Connor Dyck** of Koch Sulfur has assumed the responsibility of chairman of the TSI board. Dyck said, "It is an honour to be named TSI's Chair. I look forward to working with the Institute and its members to advocate on behalf of the sulphur and sulphuric acid industries."

John Bryant, TSI's President said, "We are excited about Connor being named TSI's Chair; his enthusiasm for the Institute will help execute our newly formed strategy and I am looking forward to working closely with him."

Haldor Topsoe says that its Chief Commercial Officer (CCO) **Amy Hebert** has left the company "by mutual agreement". Roeland Baan, Topsoe's CEO said in a brief statement: "Amy Hebert has been with Topsoe since 2018, and I would like to take this opportunity to thank Amy for her contribution and dedicated efforts in

furthering our commercial offerings. I wish her all the best in her future endeavours." The recruitment process for the next CCO of Topsoe has been initiated.

The European Chemical Industry Council (Cefic) says that **Lorraine Emsbach** has become the new assistant for the Sulphuric Acid group, which organises the European Sulphuric Acid Association meetings. Lorraine is a US national, with more than 20 years' experience in administrative functions and project management. Prior to joining Cefic, she worked as an EU Aide Project Advisor at the British Embassy in Brussels.

Shrieve Chemical Company LLC ("Shrieve"), a leading supplier of sulphur and sulphuric acid in the United States, as well as a marketer of other industrial chemicals and specialty lubricants, has announced the appointment of **George Fuller** as chief executive officer. Based at Shrieve's headquarters in The Woodlands, Texas, Fuller will be responsible for leading global activities during Shrieve's next phase of growth. Ted Threadgill, who will continue as president of Shrieve, said: "George brings a wealth of global chemical distribution experience and a proven track record, and I am excited to work with him. I am confident he will be an outstanding leader to guide the next chapter of Shrieve's growth to ensure we continue to provide exceptional service to our supplier partners and customers."

Fuller joins Shrieve with more than 30 years of chemical industry experience, including executive management roles with Univar, Hydrite Chemical, and Christensen Inc. "Shrieve has a long history of bringing an entrepreneurial mindset to the needs

of its customers and suppliers. It's an enormous privilege to continue the growth that Ted has led over the past five years, and I am honoured and excited to lead the team," said Fuller.

Australian oil and gas company Woodside says that it has named its acting CEO **Meg O'Neill** as the company's chief executive officer and managing director. O'Neill succeeds Peter Coleman, who retired from Woodside in June 2021. Woodside Chairman Richard Goyder said that O'Neill's appointment was the outcome of an extensive international recruitment process that included an exceptional field of internal and external candidates.

Goyder said: "The Board is delighted to confirm O'Neill as Woodside's sixth CEO and Managing Director. Meg's impeccable credentials and proven leadership capabilities, exemplified in recent months, set her apart as the Board's top candidate for the CEO position. The Board is looking forward to working with Meg to build on Woodside's great history and future opportunities. "Meg is an outstanding executive with 27 years' experience working in the global oil and gas industry, with a proven track record of delivery across the oil and gas value chain, making her the ideal person to lead Woodside as we significantly expand the business in a cost-efficient and sustainable way. Since joining Woodside in 2018, Meg has been instrumental in delivering operational efficiencies across our producing assets, leading the Scarborough and Sangomar developments and as Acting CEO, leading the business towards a targeted final investment decision for Scarborough this year." ■

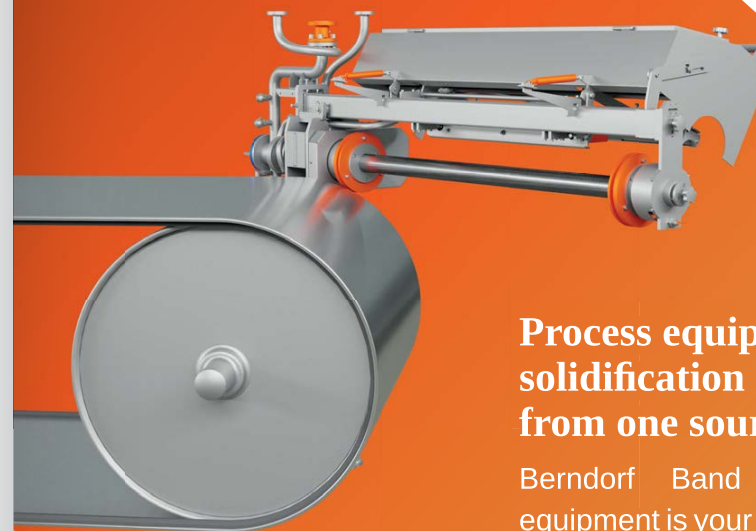

Process equipment - solidification & cooling from one source

Berndorf Band Group's process equipment is your experienced partner for the solidification and cooling of sulphur. Our feeding device *berndrop*® accompanied with our excellent steel belt cooler meet all the challenging demands of the industry.



High corrosion resistance



Pioneers in the development of pastillating units



Supplier of complete packages for the solidification of liquid sulfur into pastilles

Berndorf Band Engineering GmbH

T: +43 2672 800 0

E: engineering@berndorf.co.at

www.berndorfband-group.com

Steel Belts | Belt Systems | Worldwide Service

 **berndorf**
BAND GROUP

CONTENTS

What's in issue 396

COVER FEATURE 1

Sulphur and acid in China

COVER FEATURE 2

North African phosphates

COVER FEATURE 3

Extending acid plant life

COVER FEATURE 4

Optimising SRU operation

SULPHUR
ISSUE 396
SEPTEMBER-OCTOBER 2021

BCInsight

Southbank House, Black Prince Road
London SE1 7SJ, England
Tel: +44 (0)20 7793 2567
Fax: +44 (0)20 7793 2577
Web: www.bcinsight.com
www.bcinsightsearch.com

Calendar 2021

SEPTEMBER

14-16

"Virtual Vail 2021": Annual Sulphur Recovery Symposium – Virtual event
Contact: Mike Anderson, Brimstone STS
Phone: +1 909 597 3249
Email: mike.anderson@brimstone-sts.com

20-24

Sulphur Recovery Seminar, KANANASKIS, Alberta, Canada
Contact: Paula Zaharko, Sulphur Experts
Tel: +1 281 336 0848 Ext 101
Email: Paula.Zaharko@SulphurExperts.com

28-30 POSTPONED TO MAY 2022

8th Sulphur and Sulphuric Acid Conference CAPE TOWN, South Africa

! The following events may be subject to postponement or cancellation due to the global coronavirus pandemic. Please check the status of individual events with organisers.

Contact: South African Institute of Mining and Metallurgy. Tel: +27 (011) 834 1273
Web: www.saimm.co.za

OCTOBER

4-8

Amine Treating & Sour Water Stripping Seminar, NOORDWIJK, Netherlands
Contact: Paula Zaharko, Sulphur Experts
Tel: +1 281 336 0848 Ext 101
Email: Paula.Zaharko@SulphurExperts.com

11-15

Sulphur Recovery Seminar, NOORDWIJK, Netherlands
Contact: Paula Zaharko, Sulphur Experts
Tel: +1 281 336 0848 Ext 101
Email: Paula.Zaharko@SulphurExperts.com

NOVEMBER

1-3

Sulphur & Sulphuric Acid Conference 2021
Contact: CRU Events
Chancery House, 53-64 Chancery Lane, London WC2A 1QS, UK.
Tel: +44 (0)20 7903 2444
Fax: +44 (0)20 7903 2172
Email: conferences@crugroup.com

9-10

European Sulphuric Acid Association Autumn meeting – **Virtual event**
Contact: Francesca Ortolan, Cefic Sector Group Manager
Tel: +32 2 436 95 09
Email: for@cefic.be

China's sulphur and sulphuric acid industries



China is the world's largest importer of sulphur, mainly to feed domestic phosphate production. Sour gas in Sichuan and new refinery production, coupled with rationalisation in the phosphate sector are all leading to reduced imports, while new smelters are increasing sulphuric acid production and reducing the need for pyrite-based and sulphur burning acid production.

Above: Storage tanks at the Hengli Petrochemical refinery, Dalian, China.

As the foremost industrial nation in the world, China's various industries, from metal processing to fertilizer to refining and sour gas, have a major impact upon global demand for sulphur and sulphuric acid. China is the largest producer and consumer of sulphuric acid, over one third of the world's output, as well as the largest importer and consumer of sulphur – although its position as largest importer seems set to be claimed by Morocco this year.

China's sulphuric acid consumption has traditionally been dominated by its phosphate fertilizer industry. China has the world's second largest phosphate reserves after Morocco, and has long been a major consumer of phosphate fertilizer to feed its huge population. Around the turn of the century, China was actually one of the largest importers of phosphates, but from 2000 up to 2015 embarked upon a massive expansion of domestic mono- and di-ammonium phosphate (MAP/DAP) capacity, with processed phosphate capacity more than doubling from 2008-2015 (see Figure 1). Indeed, China overbuilt capacity to a considerable degree, and although much was

able to find its way onto export markets, much was not, as China faced stiff competition from lower cost capacity in North Africa and the Middle East.

The past five years have seen something of a shakeout in the Chinese phosphate industry, with higher cost, less efficient capacity closing. There have also been two major policy developments; the first an attempt to cap use of fertilizer and prevent over-application and its attendant issues of pollution of water courses, and to encourage more efficient use of fertilizer; and the second to cut back on air and water pollution by closing factories that breach new emissions targets or which were within 1km of the Yangtze River. This has led both to falling domestic consumption of phosphates and a reduction in capacity and production. Chinese DAP consumption peaked in 2013 at 5.6 million t/a P_2O_5 , but fell to 3.7 in 2019. MAP consumption reached 6.2 million t/a P_2O_5 in 2016, but fell to 5.7 million t/a in 2019. And over the period 2015-17, about 1.8 million t/a of DAP capacity and 2.5 million t/a of MAP capacity (both in terms of tonnes product) was idled, most of it from smaller scale producers.

The coronavirus pandemic posed a further challenge for the Chinese phosphate industry. Hubei province, where the outbreak began and was at its worst, is the centre of the Chinese phosphate industry, with 28% of the country's production capacity, and covid-related closures meant that Chinese DAP production was down by 12% in 1H 2020 compared to 2019, and MAP production was down 7%. Chinese DAP exports dropped 26% over the same period. At the same time, however, domestic demand held up relatively well, falling only 2.5% over 2020 compared to 2019. Looking forward, however, Chinese fertilizer consumption continues to be on a long-term declining trend as farmers move to more efficient use of nutrient and higher value compound fertilizers. While the rationalisation of MAP/DAP capacity of the past few years has largely passed, and there is new capacity being built, it is likely to be matched by closures elsewhere.

All of this has seen phosphates' share of sulphuric acid consumption fall, dropping 2.1% to 57% of acid consumption in 2019. At the same time, industrial acid consumption has been increasing, in spite

of overcapacity in industries like caprolactam. Titanium dioxide is a major acid consumer, representing 11.4 million t/a of acid demand in 2019, or 28% of industrial demand. Other major industrial consumers are hydrofluoric acid production, animal feed calcium, viscose fibre manufacture and so on. Industrial demand is likely to see the main gains in Chinese acid consumption over the next few years.

Overall Chinese sulphuric acid consumption was 95.2 million t/a in 2019 (100% acid basis), down 0.8% on 2018 and part of a declining trend since 2016 as phosphate capacity was rationalised. Although consumption is projected to rise over the next few years, it will likely only be by a modest amount.

Acid production

At the same time that acid consumption has plateaued, Chinese sulphuric acid capacity has been growing rapidly, mainly due to the rapid expansion of non-ferrous metal smelting. Acid capacity rose by 8.7 million t/a to 124 million t/a in 2019, mostly due to

smelter expansions. Smelter acid production capacity stood at 44 million t/a that year (36%), sulphur burning acid capacity 53 million t/a (43%) and there was still a considerable holdover of pyrite roasting acid capacity at 23.5 million t/a (19%).

Geographically, much of China's sulphuric acid output is concentrated in Hubei and Yunnan provinces, with significant production also in Guizhou, Sichuan, Shandong and Anhui. Yunnan, Hubei, Guizhou and Sichuan are major fertilizer producing regions and capacity there is dominated by sulphur burning plants, while Shandong is a coastal chemical producing region, and Anhui has a lot of smelter capacity.

Actual acid production figures are skewed slightly more favourably towards smelter acid production and against sulphur burning. Chinese acid production in 2019 was 97.4 million t/a, up 0.5%, with smelter acid representing 37.4 million t/a of this (38%), up 7% on 2018's figure. Rising smelter acid production displaced some sulphur burning output, which fell by 6% to 41.7 million t/a in 2019. Pyrite roasting still accounted for 18.2 million t/a. While pyrite

Fig. 1: Chinese phosphate production (million tonnes P_2O_5)

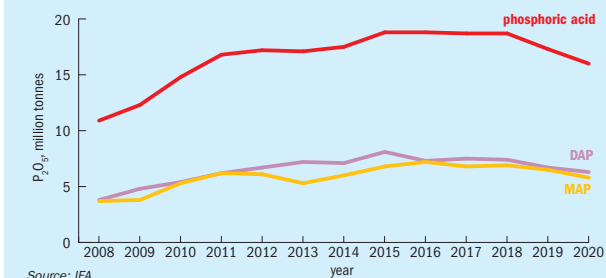

Source: IFA

Fig. 2: China's sulphuric acid production, million tonnes/year

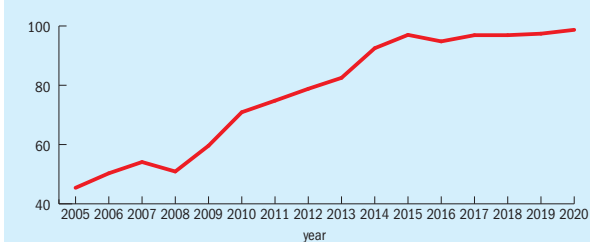

Source: National Bureau of Statistics of China

CONTENTS

What's in issue 396

COVER FEATURE 1

Sulphur and acid in China

COVER FEATURE 2

North African phosphates

COVER FEATURE 3

Extending acid plant life

COVER FEATURE 4

Optimising SRU operation

SULPHUR
ISSUE 396
SEPTEMBER-OCTOBER 2021

BCInsight

Southbank House, Black Prince Road
London SE1 7SJ, England

Tel: +44 (0)20 7793 2567

Fax: +44 (0)20 7793 2577

Web: www.bcinsight.com
www.bcinsightsearch.com

roasting remains in relative decline in the long term, credits from the iron component of iron pyrites, with the metal slag being sold into the steel industry, have kept it afloat through times of lower acid prices.

Acid production has plateaued along with demand, as Figure 2 shows, running just ahead of demand, with exports increasing. In 2019, China exported 2.2 million t/a of sulphuric acid, 70% up on the previous year. Imports were down to 530,000 tonnes, 90% down on 2018, contributing to a net increase in Chinese acid exports by 1.3 million t/a. Major destinations were Morocco, Chile and India, accounting for 80% of all exports between them. Last year saw similar total volumes shipped overseas, with smelter acid taking an increasing share of acid exports.

New smelters

The investment in smelter acid capacity has been based on rapidly increasing copper demand in China. China already represents half of all copper consumption, and its status as the main manufacturing centre for domestic appliances as well as a need for new electric power cabling is driving new demand. Chinese manufacturing has rebounded quickly after a dip caused by the pandemic in early 2020. According to the ICSG, world demand for refined copper was down 9% in 2020 because of the pandemic, but will grow by about 6% in 2021, with China driving much of the increase.

The past three decades have seen a steady increase in Chinese smelter acid capacity, with Asia's share of world copper smelter output jumping from 27% in 1990 to 65% in 2019 as smelter production in China expanded. Figure 3 shows just how much of the world's copper smelting capacity has come to be represented by Chinese production.

Last year the China Nonferrous Metals Industry Association estimated that over the period 2019 to 2023, total new Chinese sulphuric acid capacity will total 23.1 million t/a, of which 19.2 million t/a – more than 80% – will be from smelting, mainly in Hubei, Inner Mongolia, Guangxi, Gansu and Shandong provinces. However, there will also be some closures, and CNIA says that it expects smelter output to peak in the period – probably in 2022. The Chinese government is belatedly starting to put smelters under greater scrutiny and aiming to end the “blind expansion” that has characterised the past few years. Here, too, there are tightening

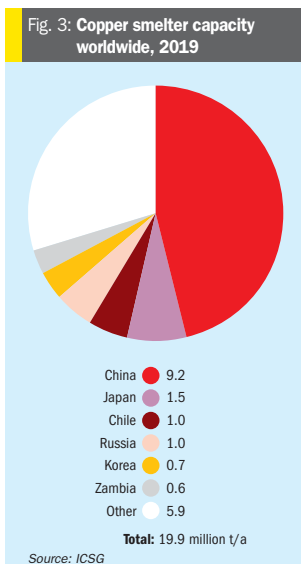

emissions targets. In April this year the CNIA set a provisional goal of bringing nonferrous metal carbon emissions to a peak by 2025 and cutting them by 40% by 2040.

While the involuntary nature of smelter acid production means that it tends to be produced provided that metal prices justify it – and global copper prices have increased by 80% over the past eighteen months – overcapacity in the Chinese smelting sector means that there have been some cutbacks and extended maintenance shutdowns which have kept acid volumes slightly lower, and while acid exports have increased, many smelters are not in a position to export acid abroad. However, this has still led to increased acid availability within China, which in turn has had a knock-on effect on sulphur burning and pyrite-based acid production.

Sulphur production

Chinese sulphur production has long been outpaced by sulphur demand for acid production. Over the first two decades of the 21st century, the rapid growth in Chinese sulphur-burning acid capacity to feed the equally large increase in processed phosphates capacity led to a rapid ramp-up in sulphur consumption, and a corresponding increase in imports of sulphur, peaking at

12.2 million t/a in 2016, at which time it represented over one third of all global traded sulphur.

However, domestic sulphur production has been rising. There was an initial spurt over the past decade from sour gas processing, mainly in the south-central Sichuan province, beginning with the large Puguang gas field in 2011, and then followed by Yuanba in 2014 and Chuandongbei in 2016. The developments have not proceeded as fast as Sinopec had anticipated, however, and the Chuandongbei field development has suffered from the exit of joint venture partner Chevron from Phases 2 and 3 of the project in 2020. While sulphur capacity from sour gas processing runs at over 3 million t/a, actual production has been around 2.2 million t/a, although new production is expected from the Zhongjiang gas field in western Sichuan, as well as Chuandongbei Phase 2, potentially adding another 700,000 t/a of sulphur production over the next few years.

There is much more sulphur coming from new refinery capacity in China. Chinese refining capacity rose from 16 million bbl/d to 17.5 million bbl/d in 2020, and is expected to reach 20 million bbl/d in 2025. One of the key developments has been the government's decision in 2015 to allow China's small, independent refining sector – the so-called ‘teapots’, which represent about one quarter of refinery capacity, and which were mostly based in the coastal Shandong province – to import crude oil. Teapots typically ran at low utilisation rates and were inefficient and often evaded tax. In return for being allowed to import crude, the government pushed teapots to upgrade, modernise and be more competitive with the state-owned giant operators like Sinopec and PetroChina. The move has boosted operating rates and allowed teapots to invest in new, integrated capacity, leading to an extra 1.4 million bbl/d of capacity among this sector alone.

Refinery sulphur output is therefore on a steadily rising trend, reaching about 4.6 million t/a last year, and projected to reach 6 million t/a by 2024. Taken with rising sour gas production, this is likely to lead to Chinese sulphur production of around 9.3 million t/a by that time. Chinese imports of sulphur have fallen steadily as domestic production increases and demand for sulphur burning acid plants plateaus, reaching 8.4 million t/a in 2020. Although the figure for 2021 may be slightly higher, the longer-term trend remains downwards. ■

Desmet Ballestra offers design and supply of plants and relevant field services for the production of sulphuric acid, oleum, SO₂ and SO₃.

- Permanent licensee of DuPont MECS® for major sulphuric acid/oleum units
- Proprietary technologies and know-how for small sulphuric acid/oleum and SO₂/SO₃ units
- Updated DuPont MECS® HRS™ system for enhanced heat recovery
- Tail gas cleaning systems and emissions control
- Wide range of production capacities and customized solutions according to specific customers' requirements
- Spare parts and technical assistance support worldwide

Over 25 units have been successfully delivered and installed worldwide.

desmet ballestra



Science
behind
Technology

Desmet Ballestra S.p.A. – Via Piero Portaluppi 17 – Milan – Italy – mail@ballestra.com

www.desmetballestra.com

CONTENTS

What's in issue 396

COVER FEATURE 1

Sulphur and acid in China

COVER FEATURE 2

North African phosphates

COVER FEATURE 3

Extending acid plant life

COVER FEATURE 4

Optimising SRU operation

SULPHUR
ISSUE 396
SEPTEMBER-OCTOBER 2021

BCInsight

Southbank House, Black Prince Road
London SE1 7SJ, England
Tel: +44 (0)20 7793 2567
Fax: +44 (0)20 7793 2577
Web: www.bcinsight.com
www.bcinsightsearch.com

New North African phosphate plants



As well as Morocco, Egypt, Algeria and Tunisia all have major phosphate industries, and all of these countries have plans to expand their capability to extract and process phosphates, though Algeria and Tunisia remain hampered by political instability.

Left: OCP's Beni Amir washing plant, Khouribga, Morocco.

North Africa is one of the world's largest phosphate producing regions, and contains nearly 85% of the world's phosphate reserves. Because of the lack of domestic sulphur recovery or smelter acid production, this means that the region's phosphate industry is a major consumer and importer of sulphur and sulphuric acid, and expansions in the region's phosphate industry continue to be a major driver of new sulphur consumption.

Table 1 shows Africa's current phosphate production. In 2019, Africa as a continent was responsible for 25% of the world's phosphate rock production, and 88% of that came from mines in North Africa – the only other major African phos-

phate mining countries are Senegal, Togo and South Africa. The table shows that Africa is also responsible for 53% of phosphate rock that is traded on international markets, with North Africa accounting for 87% of that total, and Morocco alone 60% of Africa's share. However, in terms of downstream processing Africa remains relatively undeveloped, representing only 18% of finished phosphate production, as measured by its share of phosphoric acid manufacture, with Morocco (and South Africa) representing the lion's share of this.

However, that share of finished phosphate production has been growing rapidly over the past few years, as Morocco in particular has tried to capture more of

the downstream value chain by developing its own domestic phosphate processing industries and phosphate fertilizer production, and its success in doing so has encouraged other major reserve holders like Tunisia, Algeria and Egypt to see if they can follow suit – albeit so far with more mixed success.

Morocco

Morocco remains the dominant nation in the world's phosphate industry. The country's phosphate business is almost entirely in the hands of state-owned Office Cherefien des Phosphates (OCP). OCP represents a major sector of the country's

economy, employing 23,000 people and accounting for 20% of Morocco's exports by value and about 4.3% of its GDP. Importantly, it also accounts for 31% of the international market for rock phosphate and 35% of that for phosphoric acid according to 2019 figures.

OCP mines phosphate rock at three main sites (see Figure 1): Khouribga in the north of Morocco, the more central Gantour region (Benguerir and Youssoufia) and Boucraa in the south. OCP divides its business geographically. The company's three main cash-generating units, known as the Northern Axis (Khouribga–Jorf Lasfar), the Central Axis (Benguerir and Youssoufia–Safi) and the Phosboucraa Axis (Boucraa–Laayoune), reflect the separate centres of mining and processing in Morocco and their associated downstream chemical assets.

In the Northern Axis, phosphate ore from mines at Khouribga is transported by slurry pipeline to the Jorf Lasfar complex where it is processed into phosphoric acid

and finished phosphate fertilizers, particularly DAP and MAP. Fertilizers and phosphate rock are then exported via OCP's Jorf Lasfar port. The complex is also the site of OCP's flagship Jorf Lasfar Phosphate Hub (JPH) project.

In the Central Axis, phosphate ore from mines at Youssoufia and Benguerir is transported by rail to Safi and processed into intermediates and end-products such as phosphoric acid, TSP and feed phosphates (DCP/MDCP). These are exported from OCP's Safi port. Finally, in the Phosboucraa Axis, phosphate rock from Boucraa is transported by conveyor for processing at Laayoune for export by sea.

In 2007, OCP began its \$20 billion expansion strategy, intended to run to 2025 (now extended to 2027), during which time it would double its phosphate rock production and triple its finished fertilizer production. So far, this expansion has seen rock mining capacity increase by 50% to 44 million t/a, the construction of a gravity driven slurry pipeline to take

rock from mines to Jorf Lasfar, and a huge expansion of phosphate processing and phosphate fertilizer manufacture at the Jorf Lasfar Hub. Four large integrated facilities have been built at Jorf Lasfar, each with a capacity of just over 1.0 million t/a of MAP and DAP, and each consuming 500,000 t/a of sulphur each to feed sulphuric acid and phosphoric acid capacity. Jorf Lasfar has grown to become the largest fertilizer facility in the world, with a capacity of 6 million t/a of phosphoric acid and 10.5 million t/a of fertilizers and with a production of 5.65 million t/a of phosphoric acid and 10.18 million t/a of fertilizers in 2020.

Other new developments include upgrading of the existing Euro Maroc Phosphate (EMAPHOS) lines 3 and 4 at Jorf Lasfar (originally part of a joint venture with Brazil's Bunge but brought back into full OCP ownership several years ago) by 10% each, as well as the addition of a new 500,000 t/a phosphoric acid plant, and the commissioning of a new 450,000 t/a phosphoric acid line at Laayoune, which

Fig. 1: Major phosphate producing facilities in North Africa



Table 1: North African phosphate production, 2019 (million tonnes*)

	Phosphate rock		Processed phosphate	Phosphoric acid
	Production	Exports	Production	Production
Algeria	1.35	1.27	-	-
Egypt	4.90	2.99	0.12	0.11
Morocco	35.28	9.50	8.95	12.44
Tunisia	4.06	-	0.29	1.36
North Africa total	44.69	13.76	9.36	13.91
Other Africa	6.09	2.09	0.69	1.61
Africa total	50.78	15.85	10.05	15.52
World total	207.95	29.79	70.72	87.82

Note: *tonnes product for phosphate rock, tonnes P₂O₅ for processed phosphates (MAP, DAP, TSP) and phosphoric acid.

Source: IFA

What's in issue 396

COVER FEATURE 1

Sulphur and acid in China

COVER FEATURE 2

North African phosphates

COVER FEATURE 3

Extending acid plant life

COVER FEATURE 4

Optimising SRU operation

SULPHUR
ISSUE 396
SEPTEMBER-OCTOBER 2021

BCInsight

Southbank House, Black Prince Road
London SE1 7SJ, England

Tel: +44 (0)20 7793 2567

Fax: +44 (0)20 7793 2577

Web: www.bcinsight.com
www.bcinsightsearch.com



PHOTO: OCP

Sulphuric acid plant at Jorf Lasfar.

will take OCP's phosphoric acid capacity to 8.4 million t/a at the start of 2022. From 2021 out to 2024 an extra 8.6 million t/a of new phosphate rock capacity is due to start up, mainly at Khourgiba.

The full OCP development plant has been extended to 2027, with more new Jorf Lasfar Hub developments staggered to try and prevent flooding the market.

Overseas ventures

As well as developments in Morocco, OCP has looked to develop partnerships globally, especially across Africa, in the hope of stimulating more demand for its phosphates. In some countries, including Nigeria, it has invested in blending units where products are customised to suit local soil and crop needs. The OCP Foundation has also assisted in drawing up a soil fertility map in certain African countries, to assist with this customisation.

A major deal was signed in November 2016 with Ethiopia to build one of the world's largest fertilizer facilities at Dire Dawa, with an initial capacity of 2.5 million t/a. The plant would have imported phosphoric acid from Morocco via a new terminal at Djibouti to produce NPKs, using locally produced ammonia and potash. However, social unrest and the covid pandemic have effectively halted developments there for the time being.

In 2018, OCP signed an agreement aimed at developing a fertilizer complex in Nigeria, which will use Nigerian gas and Moroccan phosphate to produce 750,000 t/a of ammonia and 1 million tons of phosphate fertilizers annually by 2025. Also in 2018, OCP signed a long term cooperation agreement with ADNOC in Abu Dhabi, including a sulphur supply agreement, with

the long term aim of developing two fertilizer production hubs, one in the UAE and one in Morocco.

There have also been technology development agreements with IBM, Prayon, DuPont, Worley, Fertinagro and China's Hubei Forbon Technology. Finally, OCP has signed a joint venture agreement with India's Kribhco to develop a 1.2 million t/a greenfield NPK fertilizer plant in Krishnapatnam, Andhra Pradesh at a cost of \$230 million, although progress on the project has been slow to date.

Headwinds

While OCP's domestic expansion has been remarkable, the group is facing some market challenges. Morocco's tenure of the Western Sahara, where the Boucraa mine is, has raised criticism internationally, and led to temporary seizures of ships carrying phosphate rock from Boucraa. The decision of the European Union to lower its limit for cadmium content of phosphate rock to 60mg Cd/kg P₂O₅ from 2022 is a potential headache, though OCP says that its products currently fully comply with all aspects of the new regulation and that it has been investing in developing cost-effective ways to address these changes while focusing on selective mining of layers with lower cadmium content.

Finally, the recent US decision to impose countervailing duties on phosphate fertilizer exports to the US might also mean that Moroccan rock, which accounts for 60% of US imports, might be diverted elsewhere. However, North America accounts for less than 10% of OCP's revenues, and its low production costs mean that it will probably be able to redirect volumes to other regions such as Brazil and India.

Algeria

Algeria has the world's third largest reserves of phosphates after Morocco and China, at 2.2 billion tonnes P₂O₅. Algeria's reserves are mainly the westward extension of Tunisia's Gafsa basin, with several prominent deposits running along the border with Tunisia. The Government-owned Enterprise Nationale de Fer et du Phosphate (Ferphos) manages Algeria's production of iron ore, phosphate rock, and other key minerals, with phosphate mining conducted by its subsidiary Société des Mines de Phosphates SpA (Somiphos). Somiphos' key site is the Djebel-Onk complex, where there are an estimated 2.8 billion tonnes of phosphate rock deposits at 25-28% P₂O₅. Two main mines send phosphate rock to a 2 million t/a capacity beneficiation plant and onwards for export at the port of Annaba. A small amount is consumed domestically, but almost all of Somiphos' production is exported. As Table 1 shows, there is currently no downstream phosphate production.

For several years, the government, with an eye to its neighbour to the west, has tried several times to develop major new projects to try and revitalise and expand Algeria's mining sector and develop downstream capacity in the same way that Morocco has. A new mining law in 2014 revised the legal standing of the industry with tax and customs duty exemptions for mining equipment and services. In 2016, Indonesian firm Indorama signed three deals worth a total of \$4.5 billion with state-owned Asmidal and Manal to develop the mine along with downstream processing facilities. The new mine, a joint venture between Indorama and Manal, would ultimately produce 6 million t/a of rock at capacity, multiplying Algeria's phosphate production fivefold. The associated fertilizer facility would include 3,000 t/d of diammonium phosphate production (Algeria already exports ammonia and so would have plenty to spare for domestic DAP production), 1,500 t/d of phosphoric acid production, and 4,500 t/d of sulphuric acid production in the first phase, with the potential for two similar complexes to follow later if the phosphate mine expanded to full capacity.

However, the plan came to nothing, and in 2018 Algeria moved on to China, with Sonatrach and Chinese companies Wengfu and CITIC signing a \$6 billion 51-49 joint venture contract to build an integrated phosphates project at Bled El Hadba, near Tebessa, increasing the rock output of the Bled El-Hadba mine from one million t/a to



Clean Technologies

Making everyday life better, safer, cleaner

For 100 years, we have partnered sulfuric acid producers with innovative technology and expert trouble-shooting technical support. And our tradition of designing advanced solutions to solve site-specific challenges continues – so we can together deliver cleaner air productively, efficiently and reliably.

Learn more on www.cleantechnologies.dupont.com

MECS®

Sulphuric acid & environmental technologies



Copyright © 2019 DuPont. The DuPont Oval Logo, DuPont™, is registered trademarks or trademarks of E.I. du Pont de Nemours and Company or its affiliates. All rights reserved.

CONTENTS

What's in issue 396

COVER FEATURE 1

Sulphur and acid in China

COVER FEATURE 2

North African phosphates

COVER FEATURE 3

Extending acid plant life

COVER FEATURE 4

Optimising SRU operation

SULPHUR
ISSUE 396
SEPTEMBER-OCTOBER 2021

BCInsight

Southbank House, Black Prince Road
London SE1 7SJ, England

Tel: +44 (0)20 7793 2567

Fax: +44 (0)20 7793 2577

Web: www.bcinsight.com

www.bcinsightsearch.com

10 million t/a, with downstream 1.2 million t/a of ammonia production and 4 million t/a of finished phosphates, including MAP and DAP, with completion scheduled for 2022. However, popular discontent that led to the ousting of president Bouteflika in 2020, coupled with infighting in the Algerian establishment, including the arrest of several prominent politicians and businessmen who were supporters of the project, led Wengfu and CITIC to pull out of the project this year. At the moment there are no international partners for Algeria's large downstream developments and domestic instability is keeping investors away.

Tunisia

Tunisia's reserves of phosphate rock are smaller than its neighbours to the west, but there had been more investment in their development than in Algeria, and by 2010 Tunisia was the world's fifth largest producer of phosphate rock, after China, the USA, Morocco and Russia, producing 8.1 million tonnes of rock. Two state owned companies operate Tunisia's phosphate sector; phosphate mining company Compagnie des Phosphates de Gafsa (CPG) and its downstream customer and processed phosphate producer Groupe Chimique Tunisien (GCT). CPG has about 8.4 million t/a of phosphate rock capacity at five mines around the Gafsa area. The rock is taken by rail to the port of Sfax where about 1 million t/a is exported, as well as to downstream production sites at Gabes, La Skhira, Sfax and M'dhilla, all of them operated by GCT, including triple super-phosphate production at Sfax and M'dhilla, and phosphoric acid (including merchant grade acid) at Gabes and Skhira, as well as downstream diammonium phosphate production at Gabes. In order to process the phosphates, Tunisia's sulphuric acid capacity is 1,100 t/d at Sfax, 1,500 t/d at M'dhilla, 8,400 t/d at Gabes and 3,500 t/d at Skhira, for a grand total of 14,500 t/d of acid or 4.8 million t/a, requiring 1.6 million t/a of sulphur at capacity.

Tunisia, however, like Algeria, has been plagued by domestic unrest following the 'Arab Spring' which began there with the ousting of president Zine El Abidine Ben Ali in 2011. Unemployment and wages were a major cause of the discontent, and the phosphate industry – the country's major foreign currency earner – became a target for protestors, with strikes and blockades affecting output. Tunisia's phosphate output

fell to 2.5 million tonnes in 2011, and has recovered only very slowly, topping 4 million t/a in 2019 for the first time, but dropping back to 3.1 million t/a in 2020. Tunisian politics remain in ferment, and in July this year, violent street protests saw president Saïed suspend parliament and dismiss his prime minister. Covid 19 and the country's chronic economic problems have made for a volatile situation. Just this month (August 2021), 12 politicians and businessmen, including managers of state phosphate companies, were banned from travelling abroad and the president says that corruption in the phosphate industry is his number one target.

Against this backdrop, plans for CPG to upgrade phosphate production as well as additional downstream processing at M'dhilla via an 800,000 t/a triple super-phosphate plant, including 200,000 t/a P₂O₅ of merchant grade phosphoric acid production, remain in disarray. CPG, which accounts for 10% of Tunisia's exports, had to be rescued from bankruptcy in 2019 after government work creation schemes dramatically expanded its wage bill while exports remained hit by industrial action.

Egypt

Egypt produced 4.9 million tonnes of phosphate rock in 2019, making it the seventh largest producer in the world after China, the USA, Morocco, Russia, Jordan and Saudi Arabia. It is also the world's third largest exporter of rock, after Morocco and Jordan. Egypt has some of the lowest production costs for its phosphate rock, and the government has decided to expand production and, like Morocco, capture more of it via downstream processing of phosphate rock.

Egypt's phosphate deposits occur in a wide belt across the centre of the country, stretching from the Red Sea inland through the Nile Valley and into the New Valley in the Western Desert. Egyptian phosphate is however generally lower grade (20-30% P₂O₅ is typical, although some deposits reach 34%). Mining is in the hands of several companies, but the two largest are the state owned Misr Phosphates and the military-owned El Nasr Company. Misr Phosphates operates the Abu Tartout mine in the New Valley area, opened in 1979, which has some of the most concentrated deposits (26-31% P₂O₅), and where annual production is around 2.1 million t/a from low cost (\$15-20/t f.o.b.), open cast operations. The other major mines are in the Nile Valley, around Sabaiya, also

surface mines, now operated by El Nasr. The National Co. for Mining & Quarries (El Wataneya) also has a mine at Aswan with a capacity to produce 600,000 t/a of rock which re-started production in 2016.

In terms of expansions, NCIC (El Nasr Company for Intermediate Chemicals, a subsidiary of El Nasr) is developing a major complex at Ain Sokhna on the Red Sea coast, which includes a 1.14 million t/a sulphuric acid plant, 450,000 t/a phosphoric acid plant, 360,000 t/a capacity DAP plant and a 250,000 t/a capacity TSP plant. Spain's Intecsa Industrial secured the €315 million (\$347 million) contract to build the sulphuric acid plant, DAP plant and TSP plant. The phosphate side of the project started up in 2019, although there is also ammonia and UAN capacity under development due for completion in 2022. In addition to this, WAPHCO (El Wady for Phosphate Industries and Fertilizers), part-owned by Misr Phosphate, is currently investing in downstream production at Abu Tartout as part of the El Wady project. The project consists of one 5,000 t/d sulphur-burning sulphuric acid plant and two phosphoric acid plants licenced by Prayon and US company K-TECHNOLOGIES, plus upgrades to ore handling, rail transportation and the port facilities at Safaga on the Red Sea. Start-up is scheduled for the second quarter of 2024.

The role of sulphur

Neither Algeria or Tunisia have any appreciable elemental sulphur production (there is a small zinc smelter in Algeria producing 70,000 t/a of sulphuric acid), and Egypt and Morocco each produce only a modest amount (typically less than 100,000 t/a), though Egypt is upgrading its domestic refinery capacity. The growth of domestic phosphate industries in North Africa thus inevitably requires large volumes of sulphur imports in order to feed sulphuric and phosphoric acid production. As a result, Morocco has become the world's largest sulphur importer, importing 5.8 million tonnes of sulphur in 2018. Tunisia and Egypt also import a few hundred thousand tonnes per year. Morocco also imports sulphuric acid; around 1.6 million t/a, but this depends upon relative prices of sulphur and acid on the open market – 2020 saw this rise to 1.7 million t/a. Over the next few years OCP will commission another 5 million t/a of sulphuric acid capacity, out to 2025, potentially adding another 1.7 million t/a of sulphur demand. ■

Tip the scales with the new VK38+ catalyst

Choosing catalysts is a percentage game. Here's a cheat code.

Choosing sulfuric acid catalysts is about balancing expenses and gains. The new VK38+ not only makes it easier to find the right balance.

Bringing enhanced performance, efficiency and a reduced climate footprint, it tips the scales to your favor.

www.topsoe.com

HALDOR TOPSOE 

CONTENTS

What's in issue 396

COVER FEATURE 1

Sulphur and acid in China

COVER FEATURE 2

North African phosphates

COVER FEATURE 3

Extending acid plant life

COVER FEATURE 4

Optimising SRU operation

SULPHUR
ISSUE 396
SEPTEMBER-OCTOBER 2021

BCInsight

Southbank House, Black Prince Road
London SE1 7SJ, England

Tel: +44 (0)20 7793 2567

Fax: +44 (0)20 7793 2577

Web: www.bcinsight.com
www.bcinsightsearch.com

Sulphur piles at the Galveston and (inset) Stockton terminals in the United States.



Sulphur supply chains: still mission critical in 2021

PHOTOS: TSI

John M. Bryant, President and CEO of The Sulphur Institute, looks at how the sulphur supply chain has reacted to the extraordinary circumstances of the pandemic over the past 18 months, and the key principles of a successful sulphur supply chain.



Steam feeds to liquid sulphur rail cars.

The last 18 months have stressed global supply chains on many products like no other period in recent history. The pandemic gets credit for sparking the difficulties, but other factors, including changes in the energy sector, will ensure that significant challenges for sulphur continue into the foreseeable future. In this article I will discuss those supply chains, their post-/mid-pandemic performance, and what companies can do to reduce supply chain risks going forward.

My comments on sulphur are based partly on personal experience with molten sulphur, but I observe that both formed sulphur and sulphuric acid share many parallel characteristics. A textbook definition of supply chain has the point of sulphur recovery as the start, with conclusion at the destination, often a sulphuric acid plant. In our supply chain scope are all transfer, transportation and terminaling assets. Not insignificantly, the software and management systems running the supply chain are also in play.

Sulphur's 'sharp edges' deserve early reference, even though they are familiar to many readers. Supply chain assets are usually product-dedicated and are often sufficiently utilised that spot or immediate access is not possible. Next, sulphur handling does carry environmental, health and safety risks and while those concerns

are manageable, specialised equipment and thorough training procedures are necessary. Finally, sulphur is also often considered to be 'double fatal', meaning that supply interruptions at either end, points of production or consumption, threaten operating rates on a very expensive asset. Supply chain failures can be damaging, to both large plant assets, and individuals!

In addition to the previously mentioned 'sharp edges' there are a plethora of significant risk factors threatening healthy sulphur supply chains. Nature delivers tropical storms, blizzards, and freezing temperatures. Accidents do periodically occur along key transportation routes, and labour-related constraints have been increasingly at the core of carrier performance problems. Plant operating rates can and do sometimes change, and a culture of 'best efforts' commercial agreements can hinder the ability of participants to quickly correct imbalances.

Sulphur's performance

Given this backdrop of high supply chain risk, how has sulphur fared during the huge challenges of 2020-21? My assessment is that sulphur has held up very well, particularly compared to other materials. Certainly the industry has had threats and supply interruptions, although

many of those issues were prompted by changes at origin or destination location points outside of the supply chain defined by transportation/terminals/transfers. Transportation delays did occur, but were typically expressed in days and percent impacted, and the challenges were less than for many comparable industries. Sulphur consumers did have to slow their usage rates, but most of their shortfalls were usually sparked by slowed recovered production. My positive assessment is a relative one, and not meant to sugar coat the headaches and losses experienced; I realise it is not comforting to hear for those that were impacted, but many sectors have fared far worse than sulphur.

So why have sulphur supply chains performed better than others? Two reasons occur to me, and both help make up the 'secret sauce' in sulphur supply chains. First, many active sulphur logistics desks operate with exceptionally smart 'people software' – staff that can sense issues early and manage change effectively. Coupled with that is a willingness to assist companies in need when trouble strikes, even if it involves ultimately helping an unaffiliated company. That cooperation is logical; the people recognise that their company supply chain will also someday need assistance.

Company supply chain footprints and strategic participation choices are typically driven by multiple factors, including degree of importance/fatal, performance history, and regional alternatives and resources. Strategic design tends to be stable, although changes are periodically observable. For example, since 2000 many companies have invested in forming assets to protect supply chains by adding optionality. Others have increased their direct participation to include trucking as they recognise community risks and wider 'rings of responsibility'. Our discussion today will focus firstly and primarily on supply chain assets in place.

When it comes to supply chain management systems, individual company factors often guide selections, and indeed many businesses leverage processes and tools already in place for other co-products or raw materials. In my experience, sulphur is deserving of special modifications, partly to address those sharp edges. Two other factors tend to drive sulphur supply chain excellence. First, sulphur companies need to have strong management principles in place. Second, it is highly beneficial to custom-adopt leading practices with rigour to fit the characteristics of your supply chain.

Key principles

The management principles and behaviours that underpin effective sulphur supply chains are:

- Linguistics! Language is usually reflective of broad philosophy and perceived value. Make sure sulphur has the status of either co-product or raw material, and banish the words waste/by-product.
- No commodity here! Never make the mistake of transacting sulphur or its services on the basis of a tender or auction. Yes, sulphur *is* a bulk commodity, but only on the basis of chemistry! Service and supply performance can make a world of difference to your business and must be carefully considered in your evaluation of price-to-value.
- Team! Even in the smallest businesses, there will be important roles, responsibilities and handoffs across multiple desks and staffers. Make sure sulphur is played as a team sport.
- Discipline and rigor required! Process rigor and flawless repetition must support daily sulphur management processes. Supply excellence begins with the successful execution of daily tasks while maintaining an eye on inventory levels relative to standards. Use inventory threshold levels and alerts.
- Change management is our business. Sulphur supply excellence comes from a system of Monitor – Communicate – Change Management – Repeat.
- Safety excellence and superior housekeeping often go hand in hand with high performing supply chains, both rooted in similar principles and practices.

Leading practices

These principles flow into leading practices which can be adopted to suit your supply chain footprint and requirements:

- Start with your annual program and plan. Include changes that address updated sulphur fundamentals, both regional, national, and global. Review at least quarterly and make appropriate changes to suit evolving marketplace fundamentals.
- Have a requirement-based discussion with sulphur customers, suppliers, and service providers. Use of a performance scorecard is often surprisingly illustrative and useful, and a great insurance policy to underwrite supply chain success.
- Develop and utilise sulphur inventory models. Add frequency and key attributes (forward months and locations) to suit your footprint complexity and risks. As scale and risks increase, focus your modelling farther up and down stream when practical.
- Sulphur logistics excellence always swings on strong communication habits, internal and external. Formalize your practices and make them routine, often a daily cadence.
- Know your options, and as supply chain risks mount – ensure you own more of them. This is not just about adding physical assets; options can be addressed commercially.
- Diversification is a textbook remedy for strengthening supply chains. In my book on sulphur, it must be evaluated in the context of practical performance. Alternatives that don't always work, don't work! A more sensible approach exists with adding absolute capacity, whether it be via an empty tank for extra offtake, or a full tank for bolstering buffer inventory.
- When supply chain risks mount, be prepared to get granular, personal, and physical. Every ton of sulphur offtake, delivery or services can and should have a performer name attached. ■

Conclusion

Sulphur supply chain health will surely be just as critical and challenging in the coming years. Some industries are investing in artificial intelligence and machine learning to help them with supply chain manage-

ment. From my desk, those tools are not particularly well suited to help with sulphur logistics. However, the good news is that there are other principles and leading practices that do fit sulphur very well and you can reduce your risks through adopting them to suit your sulphur activities. ■

What's in issue 396

COVER FEATURE 1

Sulphur and acid in China

COVER FEATURE 2

North African phosphates

COVER FEATURE 3

Extending acid plant life

COVER FEATURE 4

Optimising SRU operation

SULPHUR
ISSUE 396
SEPTEMBER-OCTOBER 2021

BCInsight

Southbank House, Black Prince Road
London SE1 7SJ, England

Tel: +44 (0)20 7793 2567

Fax: +44 (0)20 7793 2577

Web: www.bcinsight.com
www.bcinsightsearch.com

Sulphur dust control



PHOTO: 123RF
Loading sulphur at Beaumont, Texas.

Dealing with sulphur dust is an operational challenge for sulphur forming plants and sulphur storage and handling facilities.

The major threat involved in handling solid sulphur is dust. Dust can be created during the processing or transport of sulphur, or sometimes due to sulphur sublimation in melting pits or tanks. Dust can be thrown into the air by maintenance and cleaning activities, by the transportation itself, at belt transfers and stackers, by failures of transport belts such as guide chutes overfilling, belts slipping or side travels, causing spillage and falling of sulphur. If unmanaged, these conditions can create a sulphur dust explosion hazard.

Particle size is a key determinant of the explosibility of a dust. As the particle size of the dust decreases, the available surface area increases, making it easier for the dust to burn rapidly. A fine dust will also form suspensions in air more readily and remain suspended for longer than coarser particles. A shock wave from a primary explosion will also disturb any settled dust layers in the vicinity, forming a second dust cloud, which can then initiate a much larger and more devastating secondary explosion, possibly only fractions of a second after the primary.

In order to prevent dust fires and explosions there are two basic strategies; to avoid suspensions of dust in the air, and to exclude sources of ignition.

Dust minimisation

Over the years solid sulphur has moved to less friable and dusty forms, from slated or flaked sulphur to spherical or hemispherical forms. Even so, dust can be generated when solid particles rub against each other during transfer and handling operations. It is always good practice to reduce the number of transfer points and handling steps to a minimum, and try to minimise the use of front end loaders which can crush sulphur granules beneath their wheels.

To prevent dust accumulation during storage and handling of sulphur, enclosures should be constructed with a minimum number of horizontal surfaces where dust can accumulate, and access to any and all hidden areas. Good housekeeping is a must, with inspection of and cleaning of dust residues at regular intervals.

Dust suppression

While dust minimisation and good housekeeping is essential for keeping dust levels down, dust formation cannot be prevented completely. The next step then is to suppress dust. Water can be sprayed at transfer points and load-out station; the wetted particles agglomerate to each other and to larger particles, making them more difficult to be

picked up by air currents. Until the advent of dust suppressant chemicals, water was the sole means of controlling release of sulphur dust during transfer operations. However, water promotes the formation of acidity and wet sulphur corrosion. For this reason a maximum moisture content of 2% is specified in, e.g. Chinese sulphur specifications. Customers also tend to have maximum standards for water content of the sulphur, as higher water content increases the energy consumption during re-melting at sulphuric acid plants in order to evaporate the water. In general a moisture content of 1-2% is the recommended value.

The effectiveness of water for dust control is also limited by the hydrophobic nature of sulphur. This can be overcome by the use of special water-based chemical surfactants. When air is mixed with the surfactant/water mixture, foam is generated. Foam is a very effective means of dust control, made up of small bubbles 100-200 micrometers in size. When it comes into contact with dust particles the bubble breaks, coating the particle. When several come into contact they coalesce into a larger particle and can no longer become airborne as dust. Foam suppression systems create 0.5-1.0% moisture on the specified transfer point according to the transfer rate.

Sources of ignition

It is also important to remove potential sources of ignition. Solid sulphur is a poor conductor of electricity, and can easily develop a sufficient static charge to cause sparking. For this reason, every care must be taken to prevent static electricity accumulation in areas where solid sulphur is handled.

Smoking and the use of matches must be prohibited in all areas where sulphur dust is likely to be present. Naked flames or lights and the use of gas cutting or welding equipment should also be prohibited during the normal operation of the plant.

Dust layers or clouds of sulphur are also easily ignited by hot surfaces. To prevent excessive heat build-up, all equipment should be properly and securely installed to ensure the correct alignment of rotating shafts, belt tension etc. The surface temperature of plant or machinery should not be allowed to exceed $\frac{2}{3}$ of the ignition temperature of sulphur dust (i.e. 127°C). ■

ONLY
LEWIS®
LASTS

With over 127 years experience, Lewis® pumps and valves are engineered with genuine Lewmet® alloys, meaning they provide better corrosive resistance than anyone else. Our team is focused on one thing, and one thing only, creating the most durable products in the world. It's no surprise we're market leaders, there's just nothing as strong as Lewis® pumps and valves.

Learn more at onlylewis.weir

Copyright © 2018, 2020, Weir Slurry Group, Inc. All rights reserved. The trademarks mentioned in this document are trademarks and/or registered trademarks in the name of The Weir Group PLC and/or its subsidiaries.

WEIR

LEWIS®

Minerals
www.minerals.weir

Extending the life of sulphuric acid plants

Chemetics describes a variety of ways to extend the life of sulphuric acid plants. Debottlenecking, emissions reduction and/or energy recovery projects require a systematic, phased approach to maximise the potential of economic and operational benefits to the owner.

A systematic phased approach to debottlenecking

Sulphuric acid plant operators are faced with the increasing challenge of extending the service life of its existing equipment after initial start-up. As the plant ages, equipment wears out and requires routine maintenance or replacement. Quite often, there is a need to debottleneck the plant to meet future demands of acid production, metals production, etc. Environmental regulations continue to evolve which results in requirement to reduce emissions such as SO₂ and liquid effluent as well as increase energy recovery to reduce the plant's environmental footprint.

Usually, plant debottlenecking involves a combination of the following objectives:

- **Increase production capacity** by increasing gas flow to the sulphuric acid plant or by an increase in SO₂ concentration to the plant.
- **Reduce SO₂ and other emissions** by increasing conversion of SO₂ to SO₃ or tail gas treatment before the plant stack.
- **Reduce utility/energy consumption** by reducing plant pressure drop, cooling water consumption, and increasing heat recovery.
- **Improve operability and flexibility** by increasing turndown ratio, faster equipment ramp-up, etc.

In most situations, a combination of these requirements must be implemented within stringent timeline restrictions such as smelter turnaround schedules. Sometimes these objectives conflict with each another. For example, increasing SO₂ conversion might result in more catalyst volume being required which in turn will increase pressure drop (thus energy consumption) of the

Fig. 1: Step-wise approach to debottlenecking

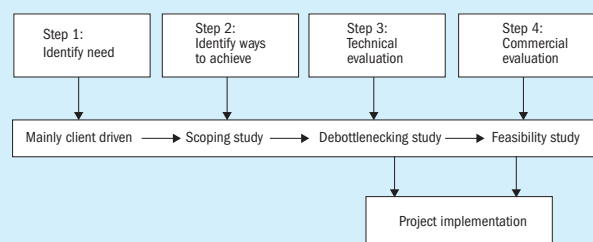

Source: Chemetics

plant. Therefore, it is critical for operators to debottleneck the plant using a holistic (plant wide) approach and thoroughly evaluate options based on technical and economic merits before implementation. Fig. 1 shows Chemetics' proven stepwise approach to plant debottlenecking.

The first step is for the plant operator to identify the need and objectives of the retrofit. This can be specific to the plant operation parameters (e.g. increase acid plant capacity by 100 t/d to match future acid consumption on site with a specific cost per tonne). It can also be driven by other opportunities, such as "Instead of replacing the existing converter with an in-kind design, what could be achieved with a reasonable investment in a new state-of-the-art converter design?".

In step 2, a scoping study should be performed to identify different technologies and methods to achieve the objectives identified in step 1. At this step, only high-level process evaluation is performed (e.g. increase catalyst loading in converter versus install a new tail gas scrubber) with economic evaluation limited to "order of magnitude" level

of detail. This enables the plant owner to select the solution(s) for a more detailed evaluation in the next step. This also eliminates the risk of spending time and money to evaluate options that have little or no merit and should not be evaluated further.

In step 3, a small number of options (usually two or three) will be studied based on actual equipment limits using simulations and actual plant operation data. At this level economic evaluation should be based on major equipment costs and factored installation costs. Economic evaluation should be more detailed (typically AAEC class 4/5 or +/- 40-50% range). At the end of this step engineering should be advanced with enough detail for the purpose of final commercial evaluation and/or basic engineering (step 4).

In step 4, the economic evaluation will usually be limited to a single configuration and incorporate elements of basic engineering where they are critical to the feasibility of the project. Specific equipment layouts and construction sequence should also be evaluated at this stage. Cost evaluation will be based on actual vendor quotations



Fig. 2: Radial flow gas exchangers.

with an accuracy of around +/- 10% to 20%. This final step usually will become the design input for project approval and implementation.

Due to limitations in budgets and time limits allowed in a shutdown to implement the plant modifications, many debottlenecking projects are implemented in phases. The phased approach (sometimes spread out in multi-year implementation) will result in higher construction costs but will reduce production losses. Sensitivity analysis to balance capital cost expenditures against revenue lost due to downtime will determine if a phased implementation is suitable.

The descriptions above provide a general overview on what objectives should be achieved for each step. It is important for the technology supplier to tailor the deliverables for each study phase to the owner's specific requirements for their capital and project approval process.

Equipment replacement

Replacing old, fouled equipment with modern, properly designed sulphuric acid equipment is a key strategy to extend the life of an existing plant. For instance, modern radial flow exchangers (Fig. 2) can be used to dramatically reduce plant pressure drop. This has the benefit of increasing plant capacity without additional blower power. More than 60% of Chemetics' designed radial tube pitch heat exchangers are used for plant debottlenecking.



Fig. 3: Fully fabricated SARAMET® alloy acid tower.



Fig. 4: Chemetics stainless steel converter with internal exchanger.

Similarly, installing new alloy (or brick lined) acid towers to replace old and worn-out, brick-lined vessels is also a common feature in retrofit projects where pre-erection of long lead items is not possible due to existing plant layout constraints. In this case a fully fabricated alloy acid tower (Fig. 3) can be dropped into the existing tower location with a relatively short turnaround time.

Replacing an existing post and grid converter with an all stainless, fully welded converter is another common strategy to unlock performance within an existing acid plant. Modern converters by Chemetics feature a fully welded design to eliminate hot gas bypassing, radial gas flow across catalyst beds for improved gas distribution,

CONTENTS

What's in issue 396

COVER FEATURE 1

Sulphur and acid in China

COVER FEATURE 2

North African phosphates

COVER FEATURE 3

Extending acid plant life

COVER FEATURE 4

Optimising SRU operation

SULPHUR
ISSUE 396
SEPTEMBER-OCTOBER 2021

BCInsight

Southbank House, Black Prince Road
London SE1 7SJ, England

Tel: +44 (0)20 7793 2567

Fax: +44 (0)20 7793 2577

Web: www.bcinsight.com
www.bcinsightsearch.com

Fig. 5: Typical recoverable energy profile for sulphuric acid plants

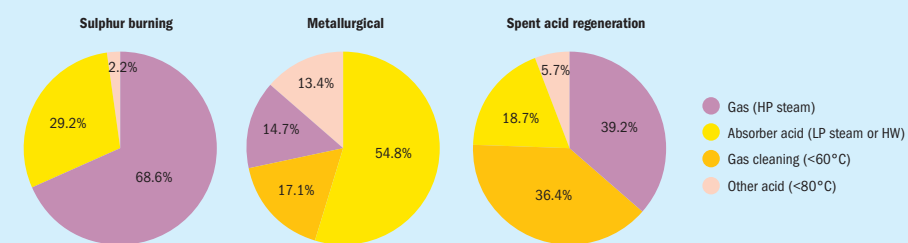

Source: Chemetics

Fig. 6: Closed loop heat recovery system to produce hot water

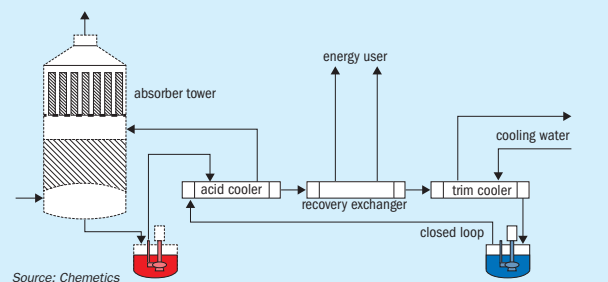

Source: Chemetics

Fig. 7: Chemetics ALPHA™ system

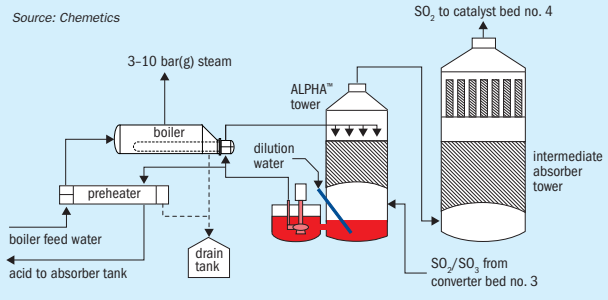

Heat recovery in sulphuric acid plants

The sulphuric acid process is highly exothermic and to maintain heat balance, excess heat will need to be removed. Heat recovery is putting this heat into any useful purpose. First and foremost, recovering heat from high temperature sources such

as the sulphur or regeneration furnace and converter to generate high pressure steam for power generation are widely practiced. However, other areas in the acid plant still have large amounts of lower grade heat and are typically disposed in cooling water. Converting this low-grade heat into lower pressure steam or hot water is

commonly done and should be considered for the plant site.

The amount of recoverable energy depends on the plant type (sulphur burning, metallurgical, spent acid regeneration). Fig. 5 shows typical recoverable energy profile for different types of acid plants. It should be noted that the heat recovered can be used inside the acid plant for items like boiler feedwater preheating or low-pressure steam addition. Or outside the acid plant battery limits, for phosphoric acid concentration, district heating, water desalination, and other local use such as raffinate heating in a hydromet complex.

It is important that the system is reliable as the value of heat recovered has much less value than the value of the acid produced. If the system is unreliable, the cost of lost production in acid will far exceed the value in energy recovered. If maximum reliability is required indirect (closed loop) heat generation is recommended (Fig. 6).

In the flow scheme in Fig. 6, the hot water produced can be used for boiler feed water preheating, a municipal heating system, or for an evaporation system such as a multiple effect distillation (MED) system for a desalination plant. One of the major benefits of such a system is that the closed loop circuit uses demin or desalinated water. This clean water will result in high reliability due to its low fouling tendency.

In the case of recovering low grade heat to produce medium pressure (4-10 bar(g)) steam, it is critical to consider the safety and reliability of such a system. The process conditions to produce MP steam requires the equipment to handle high temperature acid (190-210°C) which has a

Corrosion minimized by design



Sulzer vertical sulphuric acid pump for your industry application.

With our long experience in developing pumping solutions for industrial processes involving corrosive or abrasive media, we add value to our customers' operations through best-in-class products and services. Furthermore, we offer deep process understanding for demanding applications.

We have a proven track record and excellent references in energy efficient and corrosion resistant products for molten sulphur and sulphuric acid through all industries (e.g. oil & gas, fertilizers, metals and mining, chemical process industry). Advanced design and materials, a wide range of shaft seals and sealing systems, and the overall operating efficiency ensure a reliable and energy efficient process with minimized maintenance costs.

To learn what you can gain from our partnership, visit www.sulzer.com

Visit our booth at CRU Sulphur + Sulphuric Acid 2021 Virtual Conference & Exhibition in November 1-4.



CONTENTS

What's in issue 396

COVER FEATURE 1

Sulphur and acid in China

COVER FEATURE 2

North African phosphates

COVER FEATURE 3

Extending acid plant life

COVER FEATURE 4

Optimising SRU operation

SULPHUR ISSUE 396 SEPTEMBER-OCTOBER 2021

BCInsight

Southbank House, Black Prince Road London SE1 7SJ, England
Tel: +44 (0)20 7793 2567
Fax: +44 (0)20 7793 2577
Web: www.bcinsight.com
www.bcinsightsearch.com

very high corrosion potential. If the system is down, the cost of lost production will very quickly exceed the value of the additional low-pressure steam produced. Fig. 7 shows a schematic of Chemetics' ALPHA™ system which allows for the system to be shut down without forcing the acid plant to shut down, as well to ensure high reliability of acid production.

Emissions reduction

As environmental regulations become ever tighter for sulphuric acid plants, plant operators continue to look at new ways to reduce stack emissions such as SO₂ and NO_x. In addition, there is an increased emphasis in looking at reducing emissions during transient situations such as plant start-up and shutdown.

In general options for SO₂ emission reduction include the following options:

- improve the performance of the existing contact process by using higher efficiency catalyst, optimise catalyst loading and operating temperatures;
- convert old single contact single absorption (SCSA) plants to the double contact double absorption (DCDA) process;
- install a chemical tail gas scrubber;
- install a regenerative tail gas scrubber;
- application of a catalytic tail gas treatment process.

Improving catalyst formulations and adjusting catalyst temperatures can sometimes be achieved without changing the equipment. With the additional benefit of no additional effluent generation. However, the pressure drop will likely need to be increased which results in higher energy consumption and potential reduced acid production in the plant.

For a typical 3:1 DCDA sulphur burning acid plant, the SO₂ emissions limit is typically limited to ~100 ppmv. With an additional fifth bed (3:2 configuration) the SO₂ emissions can be reduced to ~50 ppmv range.

To further reduce SO₂ emissions additional tail gas treatment will be required after the contact plant. Chemical scrubbers such as caustic (NaOH), hydrogen peroxide (H₂O₂) and ammonia (NH₃) are widely used as the installed cost of such a system is relatively low, and they are able to reduce SO₂ emissions down to approximately 20 ppmv (Fig. 8). However, there are many downsides to such

systems, mainly dealing with storing and introducing additional chemicals on site, a visible plume (tail gas leaving scrubber will be saturated with water), additional energy consumption due to pressure drop in scrubber, and handling/treatment of effluent generated.

An alternative to traditional chemical

scrubbers, regenerative scrubbers recover SO₂ in the tail gas by first absorbing the SO₂ through the reversible reaction with an amine-based scrubber solvent (Fig. 9). Then the SO₂ gas is recovered by stripping the SO₂-rich solvent in a secondary column using steam. This concentrated SO₂ gas produced can then be recycled

back to the contact plant. Regenerative scrubbers have the advantage of opex not being impacted by inlet SO₂ concentration, and the ability to recover SO₂ gas for the acid plant. However, it is important to note that regenerative scrubbers require steam for solvent regeneration, as well as higher installed cost compared to chemical scrubbers.

Catalytic tail gas treatment can be used for SO₂ emissions control. The traditional process is to use packed beds of activated carbon to slowly oxidise SO₂ to SO₃. This process generates only weak acid which can be sent to the acid circuit as dilution water which turns SO₂ into acid product value. The major downside is that traditional activated carbon used in this process has a very high pressure drop and large volumes of activated carbon are required which results in very large scrubber sizes.

Chemetics is offering an improved process that combines the catalyst activity of the activated carbon with the low pressure drop of a honeycomb packing. This process is offered under the name Chemetics Blacktail™. This technology

involves a proprietary process which combine activated carbon particles to a lightweight matrix of hydrophobic material resulting in a very thin material that can be shaped into the low pressure drop honeycomb structure.

In the Blacktail™ process, tail gas from the contact plant enters the bottom of the tower where it is humidified with weak acid delivered through the sprays at the top of the Blacktail™ Reactor. The humid gas then enters the catalyst arranged in module layers which SO₂ is absorbed into the surface of the activated carbon, which is then oxidised from SO₂ to SO₃. The resulting SO₃ reacts with the moisture in the gas to produce ~15 wt-% H₂SO₄ solution which drains to the bottom of the reactor and is sent to the acid circuit in the acid plant. The treated gas is discharged at the top of the Blacktail™ reactor and is sent to the plant stack (Fig. 10).

The key advantage of this technology compared to both chemical and regenerative scrubbers is that it generates no effluent, nor does it require continuous chemical consumption. The only by-product it produces is weak sulphuric acid which

can be returned to the acid circuit for acid production. With very low pressure drop (up to 75% lower than equivalent chemical scrubber), the Blacktail™ can be applied in plants where the main blower has little or no spare capacity.

Summary

A systematic, phased approach to debottlenecking, emissions reduction and/or energy recovery projects maximise the potential of economic and operational benefits to the owner and eliminates the risk of spending time and money to evaluate options that have little or no merit and should not be evaluated in detail. Various techniques to accelerate tie-in schedule and minimising plant turnaround time including pre-fabrication and pre-erection of new equipment should be considered.

Replacing old and worn-out equipment with modern design sulphuric acid equipment will result in improved plant performance, increased reliability, longer plant up-time, and reduced on-going maintenance costs.

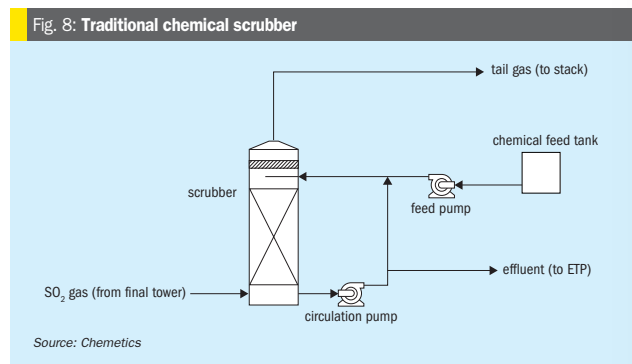

Fig. 8: Traditional chemical scrubber

Source: Chemetics

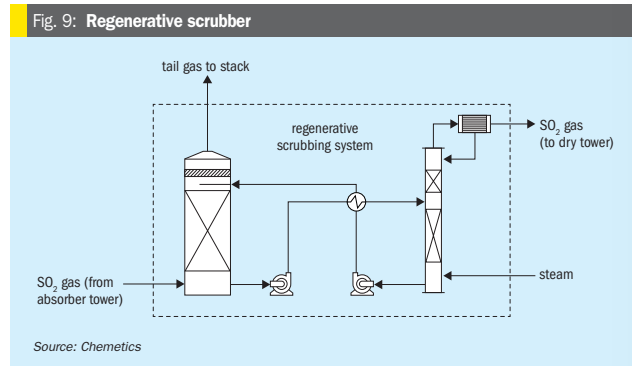

Fig. 9: Regenerative scrubber

Source: Chemetics

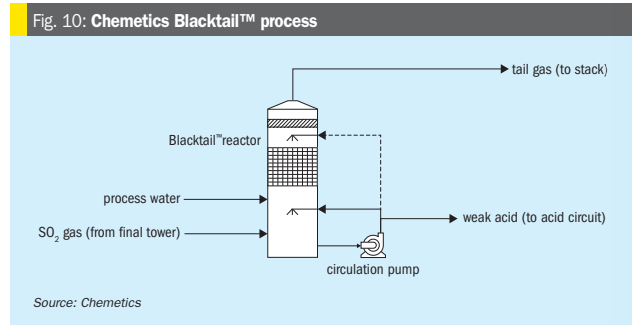

Fig. 10: Chemetics Blacktail™ process

Source: Chemetics

CONTENTS

What's in issue 396

COVER FEATURE 1

Sulphur and acid in China

COVER FEATURE 2

North African phosphates

COVER FEATURE 3

Extending acid plant life

COVER FEATURE 4

Optimising SRU operation

SULPHUR
ISSUE 396
SEPTEMBER-OCTOBER 2021

BCInsight

Southbank House, Black Prince Road
London SE1 7SJ, England
Tel: +44 (0)20 7793 2567
Fax: +44 (0)20 7793 2577
Web: www.bcinsight.com
www.bcinsightsearch.com

CHEMETICS®

Sulphuric Acid Coolers

Experience:

- Originally developed and patented by Chemetics
- Industry standard best-in-class design since 1968
- More than 2000 in service worldwide with frequent 30+ year service life
- CIRAMET® seawater coolers and SARAMET® silicon stainless steel options

Features and Benefits:

- Custom designed for optimal performance and reliability
- Designed and fabricated in our state-of-the-art Canadian facility
- ANOTROL® anodic protection, advanced proportional control with true continuous duty rated power supply.
- Now with MEMORY SEAL™ cathode gland for improved reliability

World-wide technical and inspection services to maintain safe operation and uptime in your plant.

Innovative solutions for your Sulphuric Acid Plant needs

Chemetics Inc. (headquarters)
Vancouver, British Columbia, Canada
Tel: +1.604.734.1200 Fax: +1.604.734.0340
email: chemetics.info@worley.com

Chemetics Inc. (fabrication facility)
Pickering, Ontario, Canada
Tel: +1.905.619.5200 Fax: +1.905.619.5345
email: chemetics.equipment@worley.com

worley.com/chemetics

Drying out acid condensation

Corrosion is one of the most critical aspects regarding sulphuric acid plant lifespan. One important cause of corrosion in sulphuric acid plants is acid condensation from the process gas due to inadequate drying. **E. Almeida, B. Ferraro, N. Clark, V. Machida and V. Sturm** of Clark Solutions discuss this problem and how it can be avoided with proper tower and internals design.

Adequate air/gas drying is critical for the long-term health of a contact sulphuric acid plant. A proper drying stage guarantees a significant increase in plant equipment lifespan as well as lower maintenance costs. Corrosion is one of the main maintenance and safety subjects in a wide variety of industrial processes, in sulphuric acid production it is, by far, the most important one.

An efficient humidity removal process minimises acid condensation on plant cold surfaces, a condition that is frequently found, mostly in heat exchangers such as gas-gas and economisers, but also in ducts and other surfaces. Drying tower acid carryover has also been a concern for damage in furnaces and to catalysts.

Proper selection and specification of drying tower internals is critical for adequate control of air/gas moisture content to minimise or eliminate condensation induced corrosion conditions.

Drying process

Drying sulphuric acid plant feed gas is key for minimising the risks of acid condensation on cold surfaces.

Humidity removal takes place in the drying tower. In a sulphur burning plant, operation of the drying tower can be either pressurised or under vacuum in respect to the blower position, whereas in regeneration and metallurgical plants the blower is positioned after the drying tower.

Humid gas/air enters the bottom of the tower and contacts concentrated sulphuric acid which absorbs humidity. The gas-liquid contact takes place on venturis or ceramic packed beds. Before leaving the tower the gas passes through a mist eliminator to

remove any entrained liquid, while acid is removed via a nozzle at the bottom of the tower. Thus, the drying process consists of two main stages: mass transfer and mist elimination.

Mass transfer stage

The mass transfer stage basically consists of irrigating sulphuric acid through a liquid distributor over the ceramic packed bed.

Due to its hygroscopic characteristic, when on close contact with air the acid removes its moisture. This process slightly dilutes the acid that exits at the tower bottom.

Ceramic packing is responsible for providing the contact surface for the gas and liquid phases. Increased packing specific surface area (m^2/m^3) results in more contact and, alongside higher packing heights, results in a higher total mass transfer area. A proper balance between the provided mass transfer and pressure drop is required for adequate drying without hindering plant capacity. Advanced

geometries may increase or maintain surface area with no pressure drop increase.

Another fundamental aspect is the void fraction. Lower values translate into higher pressure drops, resulting in higher energy consumption. Fig. 1 shows standard saddle packing on the left and a low pressure drop alternative on the right, which offers the same surface area but with higher void fraction and lower pressure drop.

At the top of the packing, the liquid distributor receives acid from the pump and distributes it in a homogeneous way over the tower cross sectional area, aiming for the promotion of sufficient wettability to guarantee maximum liquid film area flowing over the packing surface. Proper acid distribution not only guarantees effective mass transfer, but also allows for reduced packing height design, lowering capital and operating costs, while still maximising mass transfer and air/gas dryness.

Several types of liquid distributor are available, and selection depends on the specific set of conditions. The most

Fig. 1: A standard saddle packing (L), low pressure drop saddle packing (R)



Source: Clark Solutions



PHOTO: CLARK SOLUTIONS

Fig. 2: Trough liquid distributor with downcomers in CSX™

common liquid distributor types are: pipes and troughs with downcomers (Fig. 2).

At the bottom of the packing, the support is responsible for all packing, acid holdup and sometimes the liquid distributor, while minimally affecting gas flow to maintain proper gas distribution and low pressure drop. The most common packing support types are auto portable domes, ceramic bars, or metallic grids. Low pressure drop transition packing such as cross-partition rings are also used and provide homogeneous gas flow from the packing support.

Mist elimination stage

Contact between gas and liquid in the mass transfer stage promotes dryness at the expense of liquid sulphuric acid entrainment. The closer and more turbulent the contact between the liquid and

gas phases, the more mist entrainment is to be expected. This liquid mist needs to be collected before the gas outlet to avoid upstream corrosion and damage.

In contrast to an absorption tower, there is no chemical reaction in the drying tower, so generated mist particles are usually large, in the range of five microns and larger (an exception to this is in spent acid and metallurgical plants where the presence of smaller particles is frequent, especially when electrostatic mist precipitators are operated above design conditions or suffer performance upsets). Wire mesh mist eliminators, plain metal for conventional sulphur burner drying towers or polymer co-knitted metal for spent acid and metallurgical plants, provide sufficient mist elimination for drying towers.

In order to comply with ever more demanding requirements from acid plant

operators, modern wire mesh mist eliminators, such as Clark Solutions Maximesh®, are designed and built with multiple operating zones (Fig. 3). As a minimum:

- A heavy duty gas impingement zone situated at the bottom of the pad removes the bulk of the liquid and is built in such a way that it will resist mechanical stress.
- A high efficiency, fine mist polishing collection zone at the mesh pad upper section collects fine mist guaranteeing maximum performance.

The lower zones are usually built with a mesh geometry that will favour drainage and a wire tensile strength that will resist to mechanical stress.

Upper section collection layers use a finer wire and a geometry that increases collection efficiency. In special cases

Fig. 3: Maximesh mesh pad mist eliminator operating zones

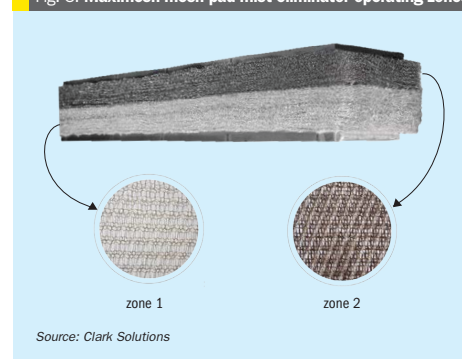

Source: Clark Solutions

Fig. 4: Dew point test device

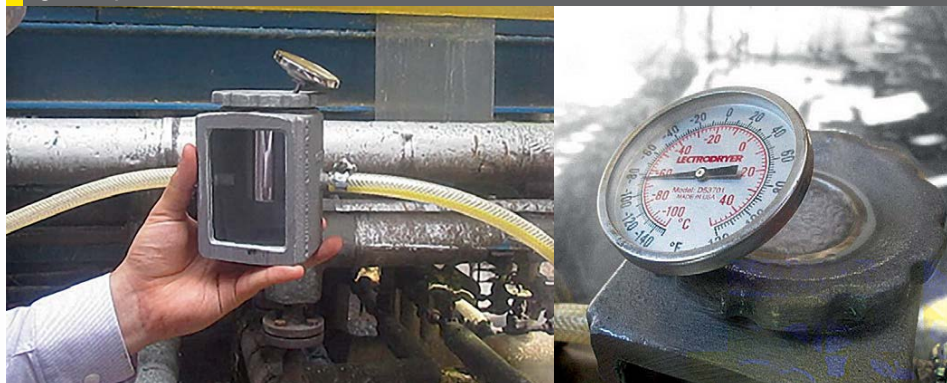
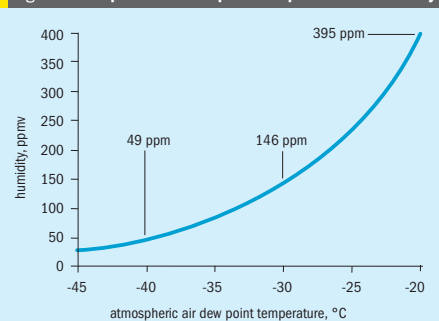
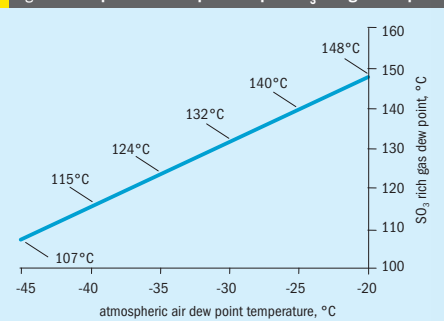

PHOTO: CLARK SOLUTIONS

Fig. 5: Atmospheric air dew point temperature vs humidity



Source: Clark Solutions

Fig. 6: Atmospheric air dew point temp vs SO₃ rich gas dew point

Source: Clark Solutions

where very high particle collection efficiency is required, polymeric materials with very high filament count and very small filament diameters can be specially knitted to the wire improving collection efficiency to levels as high as 100% for particles of two microns and above.

Materials such as chemical resistant fibreglass, PTFE or other polymers can be used to increase the mist collection efficiency in the small particle size range. This comes at the expense of some extra pressure drop, that can increase by 10-25 mm w.c. for plain metal pads to 50-75 mm w.c. for co-knitted pads.

The proper wire mesh configuration to be used in a plant is dependent upon many factors. Each configuration is used to address different plant characteristics.

Humidity effects on the sulphuric acid plant

Once the drying tower is in service, the humidity removal efficiency can be easily checked by a very simple dew point test downstream from the drying tower.

This test can be carried out using a device such as the Lectrodryer dew cup apparatus, illustrated in Fig. 4.

While feeding dry gas to the device, using the tower's positive pressure or with the support of a vacuum pump in negative pressure towers, dry ice and acetone are placed on the inner side of the device's polished cup, together with a thermometer. As the acetone and dry ice evaporate, heat is removed from the mixture and the temperature drops continuously. As it decreases, the polished cup outer surface cools. As it cools, one must observe

the sight glass and the cup outer surface. When the smallest trace of condensation is observed, the dew point temperature displayed on the thermometer is registered. This test is usually precise to within a 2-3°C range.

It is possible to calculate the gas residual water concentration with this temperature using the plot on Fig. 5.

A dew point of around -40°C is an indication of very good air dryness. Dew points above -30°C are cause for concern, particularly on those plants with low temperature economisers and other low tube wall temperature devices.

Downstream in the plant, due to the chemical reactions involved, SO₂ and SO₃ are present in the gas mixture. The SO₃ rich gas dew point temperature is considerably higher than the atmospheric air dew point temperature and the condensed liquid is sulphuric acid.

Fig. 6 shows that in an environment rich in SO₃ the higher humidity in the process gas (higher atmospheric air dew point temperature) results in higher temperatures from which the acid starts to condense.

Note that the plot does not consider SO₃ composition, since beyond a certain concentration value, the SO₃ does not significantly change the dew point temperature due to its excess. The condensation temperature can vary depending on fouling or the presence of particulates.

It is important to notice that condensation generally occurs on equipment surfaces, so the condensing temperatures displayed are wall temperatures, not the bulk gas temperatures. Wall temperatures are an average value between the cold and hot side temperatures. Depending

on the process fluids, the wall temperature will be closer to one of the sides. For instance, in an economiser, the cold side fluid is liquid water, which has a heat transfer coefficient considerably higher than the gas side, thus the tube wall temperatures will be close to that of water instead of that of the bulk gas.

Supposing, for instance, a plant with an insufficient drying stage, results in a dew point of -20°C. If there are any surfaces below 140°C, there will be sulphuric acid condensation, which will promote corrosion. These lower temperatures can be found in economisers, gas-gas heat exchangers or low-pressure boiler tube walls.

If a 200°C process gas is cooled by 120°C water in an economiser, it can be assumed that some regions of the gas-side tube wall will have a temperature of approximately 140°C, which is cold enough to promote condensation for the above-mentioned example.

Achieving an adequate drying stage

Good engineering practices can be followed to achieve both adequate humidity removal in the drying tower and sufficient mist elimination.

Mass transfer good practices

Mass transfer phenomena depend on the liquid to gas ratio, irrigation rate and density and packing height and geometry.

Regarding liquid to gas ratio, tower diameter is selected by achieving a proper gas velocity for the free cross-sectional area. The gas velocity must allow a reasonable pressure drop on the packing bed, while maintaining complete wettability of

Fig. 7: Packing height vs irrigation density

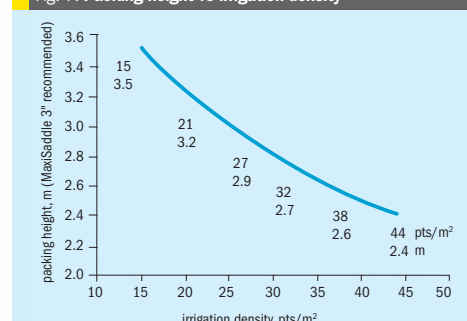

Source: Clark Solutions

the packing without entraining much liquid. Liquid flow rate is selected respecting a proper range for irrigation rate. Higher irrigation rates enhance the drying capacity until equilibrium is achieved but require more pumping and adequate distributor selection. On the other hand, operating with low irrigation rates could jeopardise the mass transfer and create dry packing sections promoting gas channelling.

Liquid irrigation density is a measure of how many pour points the liquid distributor offers over the packing bed top by unit of area. It is important for homogeneous distribution and to avoid gas channelling. In addition to the number of pour points, proper pour geometry is also of fundamental importance.

Different liquid distributors offer distinct maximum irrigation densities. For instance, for cast iron distributors, due to natural manufacturing constraints, the maximum irrigation density is typically 15 points per square metre of cross-sectional area. Clark Solutions' MaxiFlow® trough and downcomer liquid distributors are usually manufactured in CSX® high silicon stainless steel or other corrosion resistant alloy. The materials are more workable and weldable, allowing for construction geometries that improve distribution efficiency. MaxiFlow® distributors have a wide range of geometries that can achieve irrigation densities as high as 1,000 points per square metre of tower cross sectional area. MaxiFlow® trough and downcomer liquid distributors can achieve irrigation densities of several dozen pts/m². High irrigation densities promote better homogenisation of the liquid distribution demanding a lower packing height as

Adequate air/gas drying is critical for the long-term health of a contact sulphuric acid plant

illustrated by Fig. 7. All liquid distributors could be adequate if compatible packing height is offered, however low irrigation density demands a higher packing bed.

Mist elimination good practices

Apart from the mist eliminator design, adequate mist elimination depends on the liquid distributor type, liquid distributor free cross-sectional area, spray catcher availability and mist eliminator installation.

A good mist eliminator prevents liquid sulphuric acid from corroding equipment and materials downstream of the drying tower.

Poorly designed or old-style distributors (such as cast iron distributors) considerably reduce the passage of free gas around the distributor, creating a high velocity region at the packing top which increases mist generation that must be handled by the mesh pad mist eliminator. Proper distributor designs such as MaxiFlow trough with downcomers offer a large free cross-sectional area, minimising velocity in the distributor pouring area and minimising mist generation. This comparison is illustrated in Fig. 8.

Fig. 8: Mist concentration comparison

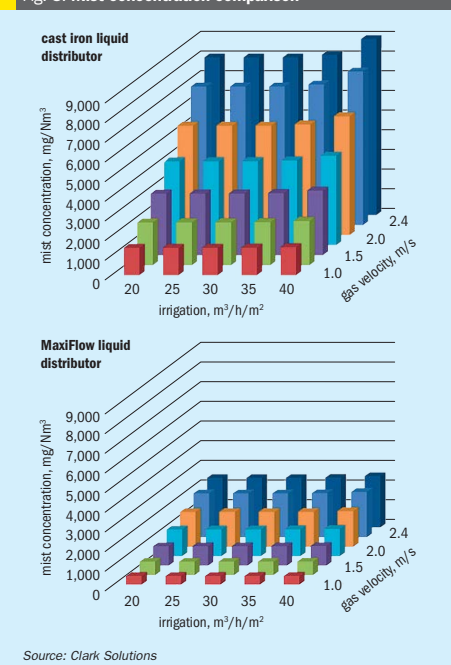

Source: Clark Solutions

A spray catcher section of at least 250 mm of height also minimises mist generation. Downcomer ends are buried into this section of 38 mm or 50 mm diameter saddles that prevent some of the mist from being entrained.

Finally, good mist eliminator installation is essential to prevent any possible gas channelling, avoiding liquid sulphuric acid carryover.

Conclusions

Adequate internals design and selection facilitates the achievement of dew point temperatures in the region of -40°C (sometimes up to -60°C), enough to minimise acid condensation on cold surfaces such as gas-gas heat exchangers, economisers, and others.

Clark Solutions uses optimisation studies for sulphuric acid tower internals, offering packing supports, random packings, special alloy liquid distributors and mist eliminators, designed to guarantee the best possible conditions to enhance plant lifespan.

www.sulphurmagazine.com

www.sulphurmagazine.com

Sulphur 396 | September-October 2021

Sulphur 396 | September-October 2021

CONTENTS

What's in issue 396

COVER FEATURE 1

Sulphur and acid in China

COVER FEATURE 2

North African phosphates

COVER FEATURE 3

Extending acid plant life

COVER FEATURE 4

Optimising SRU operation

SULPHUR
ISSUE 396
SEPTEMBER-OCTOBER 2021

BCInsight

Southbank House, Black Prince Road
London SE1 7SJ, England

Tel: +44 (0)20 7793 2567

Fax: +44 (0)20 7793 2577

Web: www.bcinsight.com
www.bcinsightsearch.com

The untapped potential of your sulphuric acid plant

Tightening regulations and growing global competition are increasing the pressure felt by sulphuric acid plant operators to reduce emissions and improve energy output. Conservation of energy is a continuous focus for operators, and environmental communities have grown more vocal in their desire for greater emissions oversight. In this article, DuPont Clean Technologies examines simple, tried, and true tactics, as well as new products and designs that can be incorporated into existing plants to address operating efficiency and emissions and to help to prolong the life of the plant.

Sulphuric acid plant operators have a number of options to extend the lifetime of assets while reducing emissions and improving energy efficiency. There are regular maintenance activities as well as equipment design improvements that can impact energy conservation and energy generation. Some of these improvements are overt while others may be more hidden, or even counterintuitive. Likewise, some of the suggestions listed should be looked at regularly by operations and maintenance teams, while others require long term planning and implementation at major turnarounds.

Energy efficiency not only means consuming less energy in operations to achieve the same output, but also finding ways to recover or even generate energy. Plants aiming for high energy efficiency should therefore approach energy improvements from multiple angles: conserving energy, improving the efficacy of equipment, in particular rotating machinery, capturing and re-using heat or steam, and transforming that heat into other forms of energy.

Beyond reducing the plant's environmental footprint, better energy management can therefore both lower operating expenditure and generate value from existing equipment and resources. The following list offers some ideas of how this can be achieved.

Steps to achieve energy and efficiency improvements

Conservation of energy

- Minimise steam losses through steam trap maintenance and steam leak repairs. Losing steam into the condensate line or leaking it into the atmosphere can be a large hidden loss of energy.
- Maintain duct integrity to avoid air ingress upstream of the compressor, as this can increase the volume of gas that the compressor must move, which in turn uses more energy.
- Keep sulphur feeds clean and maintain inlet air filters to avoid dust and deposits in the converter and boilers. Dust and salt deposits increase pressure drop.
- Maintain insulation integrity on all vessels, ducts, and piping to minimise heat loss to the atmosphere. Good insulation will also keep the plant hot during short outages and reduce heat-up time and fuel needed for heat up.
- Consider new heat exchanger designs for lower pressure drop and greater thermal efficiency.
- Consider retrofitting existing towers with lower pressure drop internals using new packing and a different mist eliminator element style or count.

- Consider new catalyst designs to reduce pressure drop.
- Review continuously operated air preheaters for maximum efficiency and lowest levels of NOx emissions. Watch for fouling or burner issues that can reduce efficiency.

Improving rotating equipment efficiency

- Consider changing fixed speed motors to variable frequency drives (VFD). This allows removal of flow or level control valves downstream, reducing pressure drop. Main compressors are good targets to review. With a VFD controlling output, inlet guide vanes or the inlet dampers can be eliminated, again reducing pressure drop. VFDs have become less expensive and should also be considered for larger pumps.
- Operate pumps at the optimal points on the pump curves. Update flow system pressure drop calculations to right-size pump impellers and eliminate unnecessary throttling.
- Consider high efficiency (85%) motors for larger installations.
- Consider soft starts on large motors to minimise voltage drop.
- Evaluate compressor and turbine drive to improve efficiency. As rotating equipment wears, efficiencies can decrease. This may require equipment supplier support to make sure the equipment operates at peak performance.

Generating/recovering more heat

- Increase deaerator pressure to allow for greater treated water preheat to transfer more of this heat to the high-pressure steam system.
- For plants with existing power islands, maximise power production from steam by maximising condenser vacuum, keeping the condenser tubes clean, and operating with a full contingency of tubes (minimise number of plugged tubes).
- Maximise the steam superheat and pressure to the turbine. Higher pressure and higher temperature provide more energy recovery. Focus on keeping the plant operating at design conditions and maintaining clean heat exchange equipment.
- Install low temperature economisers upstream of acid towers to capture more heat.
- Recover low level heat from the strong acid system for treated water preheat.
- Increase the sulphur dioxide (SO₂) gas strength to 12% for optimum steam production. Modernising the catalyst selection and placement is key to operating at higher gas strengths.
- For spent acid regeneration plants, maximise air preheat to SAR furnaces.
- For spent acid regeneration plants, consider oxygen enrichment to limit fuel gas usage.

emissions control has also had a large part to play, with governmental regulation and public opinion imposing every tighter restrictions on emission limits around the world. While global emissions standards are less than 100 ppm SO₂, local regulatory requirements in many areas are much lower at 20 ppm. Satisfying local communities and pressure groups has become a key element of sulphuric acid plants' right to operate. The conundrum has been how to cut emissions reliably, lastingly and in a way that does not impact but aid operations productivity.

The simplest way to reduce emissions is to optimise catalyst selection in terms of loading, and to choose the right type of catalyst for each catalyst bed, as shown in the two examples below:

Example 1

A metallurgical customer with a conventional double absorption plant with MECS[®] HRS[™] had a design feed gas composition of 14.0% SO₂ and 14.0% O₂. The converter contained conventional catalyst in bed nos. 2 and 3 with a 50% cap of caesium-promoted Cs-120 in pass no. 1 and Cs-110 ring catalyst in bed no. 4. The caesium-promoted catalyst in pass no. 1 was used to control the highly exothermic reaction in the first pass. Operating the inlet temperature to the first pass at 390°C, the outlet temperature could be controlled to 635°C. The overall result was a stack emission of less than 75 ppm SO₂.

Example 2

A sulphur burning customer needed to reduce stack emissions to 100 ppm, adjusted to an 8% O₂ basis. The plant was

SO₂ removal technologies for lower stack emissions

Improving energy efficiency is, however, only one aspect of reducing the ecological impact of sulphuric acid plants. For many years now,

Fig. 1: Typical range of application of different MECS[®] technologies based on the inlet gas concentration

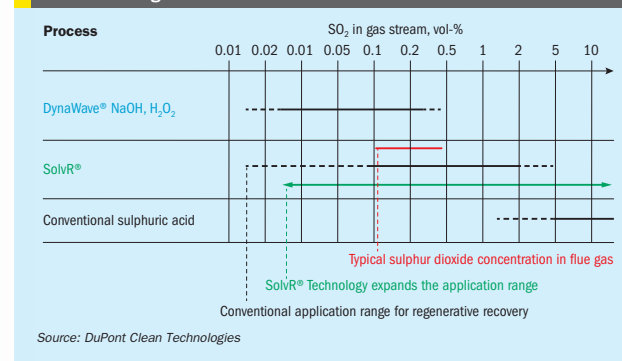

CONTENTS

What's in issue 396

COVER FEATURE 1

Sulphur and acid in China

COVER FEATURE 2

North African phosphates

COVER FEATURE 3

Extending acid plant life

COVER FEATURE 4

Optimising SRU operation

Ultra- low stack emissions

The two basic options to reach ultra-low stack emissions levels are:

- wet scrubbing with a base or hydrogen peroxide;
- regenerative scrubbing.

The economic viability of each approach depends on many variables. Two of the more important factors to consider are the gas flow rate and the concentration of sulphur dioxide in the inlet gas. Fig. 1 shows the typical application range of different MECS[®] technologies based on the inlet gas concentration. In the case of a low gas flow and/or a low SO₂ concentration, typically the most attractive approach is to use a wet scrubber with either sodium hydroxide or hydrogen peroxide since scrubbers represent lower capital costs than regenerative scrubbing. However, as the gas flow and/or SO₂ concentration increases, the raw material, handling, and disposal costs dominate, and the operating costs overwhelm the savings on capital. In this case, the use of a regenerative technology such as MECS[®] SolvR[®] becomes very economically attractive.

The economics of wet scrubbing

Caustic wet scrubbing, such as MECS® DynaWave® scrubbing, typically represents the lowest capital investment approach and can be applied when the gas flow and/or the concentration of sulphur dioxide in the inlet gas to be treated is relatively low. The sulphur dioxide is converted to sodium sulphite which is then oxidised with air to sodium sulphate. The sodium sulphate generated will then be sent to the wastewater treatment facility. As the flow and concentration of sulphur dioxide in the feed gas increases, the cost of raw materials and waste disposal costs increase quickly and the small savings in capital are overshadowed by the operating costs. For a flow of about 100,000 SCFM and an inlet concentration of 1,800 ppm SO₂ in the inlet gas, the savings in capital will be paid back in about 19 months. When the concentration of SO₂ is higher than 1.8 vol-% then the incremental capital can be paid back in only two months through the savings in operating costs.

Alternatively, hydrogen peroxide could be used to react the sulphur dioxide to form sulphuric acid. A slight excess of peroxide is used to ensure a complete

reaction and the excess is decomposed in another vessel. In this case, the sulphur dioxide is recovered as product which is not the case for caustic scrubbing. Unfortunately, the cost of hydrogen peroxide is higher than the value of the sulphuric acid produced, and as the concentration of SO₂ increases, the operating costs increase proportionately.

In a limited number of applications, the sulphur dioxide could be reacted with caustic to both reduce emissions and produce an aqueous solution of sodium bisulphite. This configuration would require a larger capital investment to produce a sufficiently high-concentrate solution of sodium bisulphite that could be sold commercially. Special attention needs to be paid to avoid generating larger concentrations of sodium sulphate that may render the product not saleable.

This process will require a tail gas scrubber to ensure that sodium bisulphite is produced. In addition, storage tanks for caustic and the product sodium bisulphite need to be installed. Furthermore, to market the co-product, clients need to be relatively close to avoid excessive shipping costs. As there is a limited market for this co-product, this approach is not commonly utilised.

Regenerative SO₂ scrubbing

The MECS® regenerative SO₂ technology, SolvR®, absorbs sulphur dioxide in the inlet gas at concentrations ranging from 300 ppm to 50 mol-%. It has low pressure drop that makes it amenable for installation in existing manufacturing facilities without requiring significant changes to existing equipment. The main input utility is steam that is used during the stripping step of the process.

MECS® SolvR® process description

The MECS® SolvR® absorber is a packed tower which removes the sulphur dioxide from the hydrated gas with lean solvent. The clean exhaust gas (containing less than 20 ppm SO₂) is sent to the stack. Emission levels can easily be controlled or adjusted by adding more lean solvent to the absorber and by adding steam during stripping (Fig. 2).

The rich solvent, which now contains sulphur dioxide, is sent to the lean-rich heat exchanger where most of the sensible heat is recovered by exchanging it with the hot lean solvent. The rich solvent having been taken to a temperature of about 200°F (94°C) is then fed it to the stripping column. The absorbing solvent essentially

Fig. 2: MECS® SolvR® system

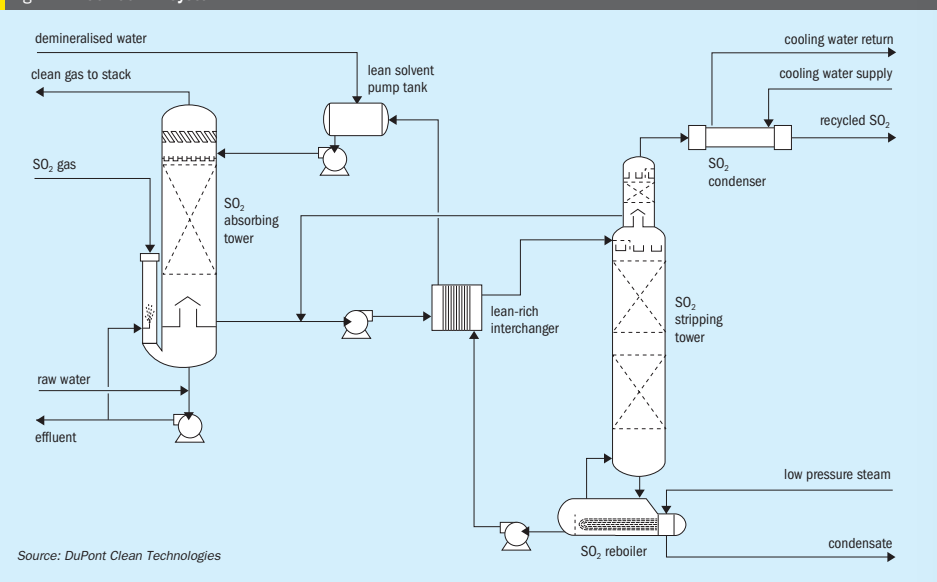

Source: DuPont Clean Technologies



Industrial Ceramics Limited
Established 1946

Industrial Ceramics LTD (ICL) has been specializing in the manufacture of tubesheet protection systems (ferrules) and other speciality shapes for over 55 years.

ICL designs are used in plants all over the world, protecting WHBs from high temperature corrosion and degradation in SRUs, Methane Reformers, Sulphuric Acid plants and other Petrochemical applications.

Technical Support includes:

- CFD modelling (to used to determine optimal design and temperature profile across the tubesheet lining)
- RCA support - We can bring our wealth of experience to your RCA team if you are having tubesheet lining reliability issues.

ICLs key market strengths are:

- Superior material properties (excellent high temperature strength and thermal shock resistance)
- Reliability
- Design
- Installation
- Technical Support

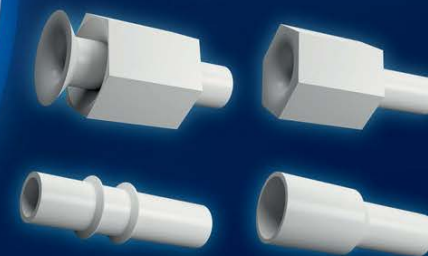

EXperience
pertise
ceptional Support

Milton, ON, Canada
+1 (905) 878-2848

www.industrialceramics.com
salesdesk@industrialceramics.com

Emergency: +1 (905) 699-9373 (6 AM - 8 PM EST) +90 (531) 858-8033 (8 PM - 6 AM EST)

CONTENTS

What's in issue 396

COVER FEATURE 1

Sulphur and acid in China

COVER FEATURE 2

North African phosphates

COVER FEATURE 3

Extending acid plant life

COVER FEATURE 4

Optimising SRU operation

SULPHUR
ISSUE 396
SEPTEMBER-OCTOBER 2021

BCInsight

Southbank House, Black Prince Road
London SE1 7SJ, England
Tel: +44 (0)20 7793 2567
Fax: +44 (0)20 7793 2577
Web: www.bcinsight.com
www.bcinsightsearch.com

has no vapour pressure. Consequently, above the feed tray there is only water and sulphur dioxide. The overhead gas containing about 95 mol-% sulphur dioxide and 5 vol-% water is then sent to the drying tower and eventually converted to sulphuric acid.

Since most gases contain oxygen in the feed gas (11.5 mol-% in this system), some of the sulphur dioxide reacts, forming SO₃, which in this system is in the form of sodium sulphate. About 0.5% of the sulphur dioxide is oxidised and the sulphate formed is removed by the anion exchanger.

The MECS[®] SolvR[®] system offers several advantages when compared to other regenerative scrubbing systems including:

- a solvent with several unique properties, i.e., environmentally friendly, minimal make-up requirements and low cost;
- a steam stripping arrangement that utilises novel techniques developed to optimise energy efficiency;
- an effluent volume that is minimal and consists primarily of sodium sulphates (no acids) which are easily managed from an environmental perspective and often can be discharged directly to the plant sewer.

Comparison of SO₂ abatement technologies

Table 1 illustrates different options for modifying an existing single absorption plant or when considering a new plant. These options are double absorption, scrubbing, and regenerative technology. Traditional wet scrubbing generates a large amount of effluent that needs to be treated and disposed of. The disposal costs as

well as the raw material costs increase with the rising flow rate of SO₂ in the gas stream. Regenerative technology has low effluent and low operating costs; however, the capital cost is higher than for traditional wet scrubbing technologies.

Green energy - recovering more heat

Plant owners, neighbouring communities, and environmental groups all like the green energy that is co-produced in the manufacture of sulphuric acid. The MECS[®] HRS[™] heat recovery technology for sulphuric acid plants allows them to produce carbon-free energy and has close to 40 years of accumulated operation, with over 100 units installed worldwide. As demand across the globe grows for investment in green, carbonless energy, the MECS[®] HRS[™] technology continues to improve and expand. Refer to Table 2 for a summary of the MECS[®] HRS[™] steam generation technologies.

In the sulphuric acid process, energy is released through combustion and exothermic chemical reactions, and is recovered as high-pressure steam. Low level energy, like the heat from SO₃ hydration, is normally not economical to recover and is therefore rejected to the cooling tower. With MECS[®] HRS[™] technology, sulphuric acid plants can significantly increase their thermal efficiency by upgrading and recovering this low-level energy as medium pressure steam (up to 150 psig (10 barg)). Steam generation typically ranges from 0.4 to 0.6 tons of steam per ton of acid produced, depending on the SO₂ concentration and water balance considerations. This steam can then be used to produce electricity in

the order of 3 MW per 1,000 t/d acid.

In the MECS[®] HRS[™] technology, heat is removed in the HRS[™] boiler, and water and steam are added in the process to control the acid concentration. Energy contained in the product acid may be recovered by heating water in the HRS[™] heater and pre-heater. This heating results in additional steam generation as well as reduced cooling water use in the plant.

MECS[®] SteaMax[™] HRS[™] exports more medium pressure steam than a typical MECS[®] HRS[™]. It raises the ratio of dilution steam to dilution water and increases generation of medium-pressure steam. Low-pressure steam is added to the system for acid dilution. The energy in this low-pressure steam is then recovered as medium pressure steam in the HRS[™] boiler. This upgraded steam has more value and gives plants greater flexibility in steam use and customisation to site-specific energy requirements and local conditions.

The MECS[®] MAX3[™] technology is the next stage in sulphuric acid plant energy upgrades, allowing for up to 20% more high-pressure steam to be exported from the sulphuric acid plant. By employing a heat exchange networking system, MAX3[™] technology shifts the MECS[®] HRS[™] energy that would normally be used to generate medium-pressure steam in the HRS[™] boiler to a high-pressure steam system that allows for greater production of high value, high-pressure steam.

MECS[®] MAX3[™] technology can also integrate with the SolvR[®] technology, resulting in an ultra-low emission, high efficiency sulphuric acid plant design, especially useful for grass roots installations. Utilising MECS[®] MAX3[™] and SolvR[®] technologies

will allow acid plants to produce high-quality acid at nameplate capacity or above while maintaining ultra-low greenhouse gas emissions. Additionally, the resulting low effluent rates will minimise water losses. This plant arrangement maximises carbonless, green energy production that can either be turned into power for sale or used internally.

But energy efficiency and air emission reduction are only two on a long list of objectives for sulphuric acid plant operators. In a high acid environment, the longevity and reliability of equipment are also important considerations and cost factors. MECS[®] HRS[™] and MAX3[™] are designed with durability and low maintenance in mind. An example is a sixteen-year-old plant with MECS[®] HRS[™] technology, operating in China that has an on-stream time greater than 98%. Overall, downtime including turnaround time at this plant accounts for less than 2.5 % of the cost of equipment replacement.

The selection of the right equipment with demonstrated reliability and correct maintenance are key to a long plant life. State-of-the-art equipment such as

Table 2: Example of different MECS[®] HRS[™] steam generation technologies

	kg/h IP	t/t IP	kg/h HP	t/t HP
MECS [®] HRS [®] with no steam injection	47,000	0.47	130,000	1.3
Conventional steam injection	52,800	0.53	130,000	1.3
SteaMax [™] HRS [®]	63,800	0.64	130,000	1.3
MECS [®] MAX3 [™]	35,000	0.35	157,550	1.6

IP – medium pressure steam; HP – high pressure steam.
The example assumes that low-pressure steam is available at battery limits for steam injection.
The SteaMax[™] HRS[™] assumes 100% steam injection. The plant life is 30 years.
Source: DuPont Clean Technologies

Brink[®] AutoDrain[™] mist eliminators and new catalyst can reduce maintenance and extend plant life. Adding new bolt-on-systems can increase maintenance needs but will bring other benefits as discussed above.

Conclusion

Reducing emissions, improving energy efficiency while unlocking value from existing assets and prolonging the life of a sulphuric acid plant are no simple matter. There is no single solution that will address all these

challenges. They rather need to be viewed holistically so that any changes made to existing assets are aligned with each other to achieve maximum benefit. As outlined, it is possible to design or upgrade sulphuric acid plants to achieve a balance of energy efficiency, emissions reduction and plant longevity through technology solutions such as MECS[®] MAX3[™] and regenerative SolvR[®] that are not only economically viable but maximise carbonless energy generation at the same time as achieving ultra-low carbon emissions. ■

YOUR EXPERTS FOR BURNERS AND COMBUSTORS



COMBUSTION SOLUTIONS



Combustion systems and equipment for

- ACID/TAIL GAS
- LIQUID SULFUR
- SPENT ACID
- CHEMICAL/PETROCHEMICAL RESIDUES
- OXISPRAY & OXIJET
- Solutions for boosting your acid process
- SRU BURNER

CS Combustion Solutions GmbH
Lemböckgasse 49/Objekt 2/D/1.0G
1230 Vienna, Austria
T +43 1 907 44 16
sales@comb-sol.com
www.comb-sol.com

Table 1: Comparison of SO₂ abatement technologies

	Double absorption	Caustic scrubbing	Peroxide scrubbing	NaHSO ₃ scrubbing	SolvR [®] regen
Equipment	<ul style="list-style-type: none"> • HIP • CIP • Converter • FAT • Pump tank • Cooler • Booster fan 	<ul style="list-style-type: none"> • Absorber • Oxidising air blower • Oxidation vessel 	<ul style="list-style-type: none"> • Absorber • H₂O₂ tank • Excess H₂O destruction vessel 	<ul style="list-style-type: none"> • Tail gas scrubber • NaHSO₃ storage tank 	<ul style="list-style-type: none"> • Absorber • Stripper • Interchanger • Reboiler • Solvent regeneration
Effluent	None	20 wt-% Na ₂ SO ₄	40% H ₂ SO ₄	40 wt-% NaHSO ₃	Na ₂ SO ₄
Raw materials	None	NaOH @ \$450/ton	H ₂ O ₂ @ \$900/ton	NaOH @ \$450/ton	Solvent + NaOH LP steam
ΔP	80 in WC	6-8 in WC	6-4 in WC	8-10 in WC	6-2 in WC
Attainable emissions	100 ppm	5 ppm	100 ppm	100 ppm	10 ppm
Reactions	SO ₂ + ½ O ₂ → SO ₃	SO ₂ + ½ O ₂ → SO ₃	SO ₂ + ½ O ₂ → SO ₃	SO ₂ + NaOH → NaHSO ₃	R + SO ₂ ⇌ R SO ₂ complex

Source: DuPont Clean Technologies

CONTENTS

What's in issue 396

COVER FEATURE 1

Sulphur and acid in China

COVER FEATURE 2

North African phosphates

COVER FEATURE 3

Extending acid plant life

COVER FEATURE 4

Optimising SRU operation

SULPHUR
ISSUE 396
SEPTEMBER-OCTOBER 2021

BCInsight

Southbank House, Black Prince Road
London SE1 7SJ, England

Tel: +44 (0)20 7793 2567

Fax: +44 (0)20 7793 2577

Web: www.bcinsight.com
www.bcinsightsearch.com

Digital tools to optimise the operation of your sulphur recovery unit

Comprimo has recently launched two new solutions to make the most of existing data and to improve customer's operations and customer knowhow: Comprimo Insight – an intelligent sulphur plant dashboard, and Comprimo Immerse – a dynamic sulphur plant simulator. In this article, Comprimo goes into the details of how Comprimo Insight and Comprimo Immerse are being implemented for its customers.

J.-W. Hennipman, E. Ticheler, Comprimo Netherlands and M. van Son, Comprimo Canada.

For over five decades, Comprimo has licensed gas-treating and sulphur recovery units (SRUs) for the oil and gas industry. Many of these licensees have chosen to engage with Comprimo in a so-called continuous services contract to stay in touch with Comprimo's process experts and get advice in case of problems in the unit or on how to optimise their facilities with respect to emissions, catalyst lifetime and energy consumption. Also, in case of troubleshooting this provides a direct contact from the plant operations people to the assigned Comprimo technology experts. Traditionally, the communication related to the continuous services of the licensed units was done by sending screenshots with distributed control system (DCS) data, large data files in Excel and organising site visits for the Comprimo experts to interact with operations. During the site visits, sometimes a short training for operations was organised to highlight specific operational situations that had caused issues.

The sulphur recovery unit is not a profit-making unit in a refinery or gas plant, and is only required to obtain a license to operate from the local authorities with respect to sulphur emissions. Therefore, costly data transfer and 24/7 licensor support like there is for hydrocracker and fluid catalytic cracking units is typically not implemented. However, with the digital revolution, Comprimo recognised the potential for upgrading the current set of services to customers at an

affordable price level. A quest for implementation of new digital services was described previously⁴.

Comprimo has developed two tools that allow customers to understand their units better and provide the opportunity to improve the overall performance of the units. Using the first tool called Comprimo Insight, the historic data from the customer's plant is periodically compressed as one-minute average values and shared with Comprimo via a secured methodology. The data is then automatically validated and processed and made available to the Comprimo technology expert for the interpretation of long- and short-term possible operational improvements. Key performance indicators are calculated automatically and trended as well as e.g., expected remaining catalyst life, energy optimisation, plugging, etc. This can be done without requiring customer data collection, communication, or site presence. Also, in case of troubleshooting, near real-time data will be available immediately and reasons for upsets can be identified. Remote assistance for start-up and optimisation of the units can also be organised on very short notice.

In addition to providing the ability to use the Insight tool, Comprimo also developed a training tool, called Comprimo Immerse, which mimics the operation of the SRU in a virtual environment. This tool can be fully customised to a customer's DCS representation, thereby providing the ability to train operators and engineers on a digital replica of their SRU. The Comprimo Immerse

tool can be used to reduce onboarding time of new operators and train operators to manage start-ups, shutdowns and upset situations in real time without impacting actual operations and related emissions.

Comprimo Insight

One of Comprimo's customers was sending over a large Excel file with hourly average plant data from the whole past year and requested a detailed report about the performance of the units and optimisation recommendations. Processing all the data was done manually in Excel, preparing all the key performance indicators (KPIs), catalyst activity trends, virtual analysers, comparison with simulations, etc. The trends were copied to a Word report and the technology expert provided observations and recommendations for each trend. For a total of five plants, this was about four weeks of full-time work.

Comprimo recognised that for immediate assistance requests, this work method was not effective in providing correct and quick feed-back to the customer. After a few years of using this work method via Excel datafiles, cloud computing got the attention of the refinery world and Comprimo's customer was interested to share its data in an automated way, not only for the sulphur recovery unit, but also for its other licensed units. Also at that time, Comprimo started efforts to develop a Proof of Concept (PoC) for data-sharing. Initially, the data was

sent via a daily email that used Windows Scheduler and Excel-VBA to collect the data from the historian automatically. This method worked but was not very robust as it required a stable PC that was always on. And from a cyber security point of view, it's not very elegant as there is no clear control of what data is sent over. The only positive, but also security wise weak point, is that it could be set-up by the customer unit engineer and Comprimo's technology expert without heavy IT involvement.

Coincidentally, the customer in question started a project to collect all plant data from several sites in the cloud. Additionally, a PoC for data sharing via the cloud was set-up. Special licenses for the historian database were required to be able to transfer the data to the cloud, in this case Azure. Near real-time data, with a few minutes time delay, was available to Comprimo in read-only tables. Initially the data was processed on a single PC from one of the technology experts, but eventually Worley IT assigned an Azure subscription for Comprimo. Via this Azure subscription the data is processed in the Worley cloud environment and via the data-share utility, the customer has read-access to the results only. The schematic representation of the data flow and processing is shown in Fig. 1.

By sharing only the historian data and results from calculations and simulations, the intellectual property (IP) of the correla-

Fig. 1: Schematic representation of the data transfer model from customer to Worley and back

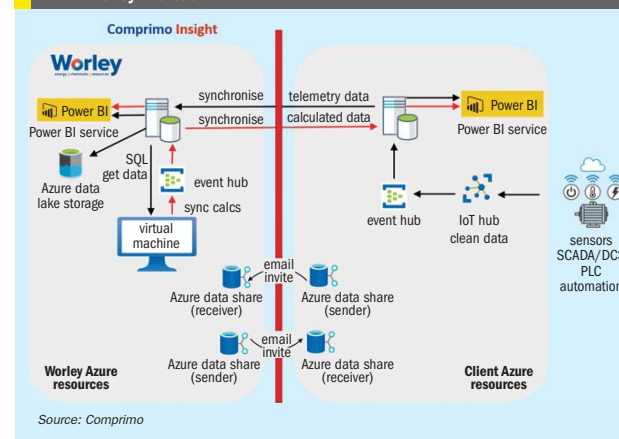

tions and in-house design and simulation software can be kept with the licensor. The visualisation model, which includes the dashboard and trending of the data is done with Power BI. And since the visualisation model processes only data points, it can be shared with the customer, with the advantage that the customer engineer and the technology specialist use the same interface, which enhances communication. Although Power BI is not a common tool

for customer engineers yet, it is used and known in most organisations. But in principle any visualisation tool can be used. It is even possible to feed back the results into the historian database and use the regular historian visualisation tools known to the customer engineers.

A snapshot of what the visualisation looks like is provided in Fig. 2, although this will be customised for each customer depending on the requirements.

Fig. 2: Example of part of the visualisation developed for a customer

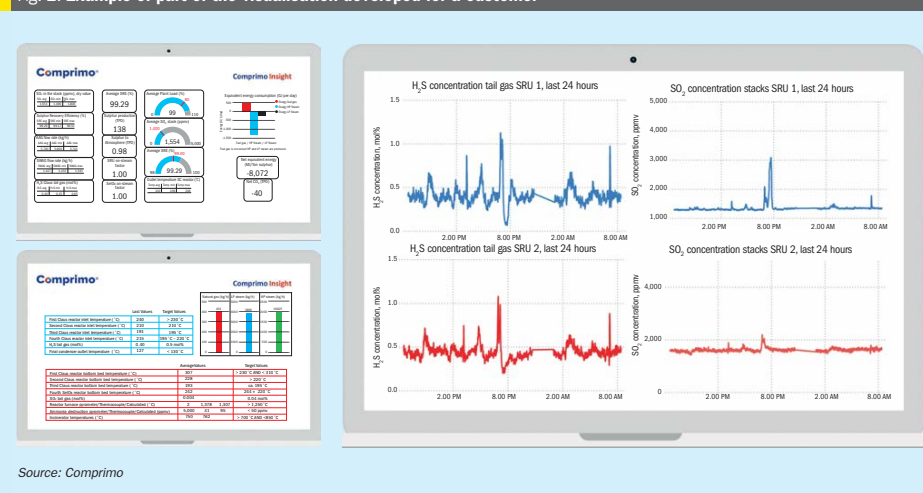

Source: Comprimo

Fig. 3: Combustion chamber temperature measured by the pyrometer, thermocouple and calculated via simulations

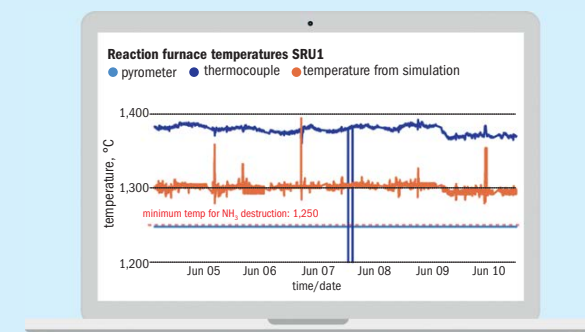

Source: Comprimo



Fig.4: Result of overheating of the main combustion chamber.

The visualisation is divided in a dashboard function, which gives the customer engineer a quick overview of the status of the unit. It also includes a trending part with all the KPIs and parameters that need to be followed over time to monitor the health of the unit. The customer engineer can use the dashboard to interact with operations in case there is a setpoint or parameter not within the normal operating window. Maybe there is a good reason that there is a deviation from the operating window, but the tool provides a way of monitoring and registering deviations. If the site has more SRUs, it is possible to compare operation parameters as shown in Fig. 2 for the H₂S concentration in the tail gas and the SO₂ concentration in the stack. This particular SRU line-up is a three stage Claus reactor followed by a SUPERCLAUS® reactor. As

an example, in Fig. 2 there is indication of an upstream upset, because around 6 pm there is an H₂S spike in both units at the same time. However, one of the SRUs has more difficulty to recover from the upset than the other one as is shown in the difference of height in the SO₂ spike in the stack. This may have been caused due to tuning of the H₂S feedback control loop. In both cases, the SO₂ emissions were higher than allowed and local environmental regulations can be very strict when limits are exceeded.

Other features that have been developed are virtual analysers. Based on the plant data, some of the instrument readings, e.g., temperature in the combustion chamber or the H₂S measured by the tail gas analyser, can be checked using specific algorithms or simulations. An example

for trending the pyrometer and thermocouple readings next to the temperature obtained from simulation is provided in Fig. 3. The temperature obtained from simulation provides an independent method to verify the thermocouple and pyrometer, provided the flow measurements to the SRU are sufficiently accurate.

There have been incidents where incorrect temperature indications, especially during natural gas firing, have led to overheating of and damage to the combustion chamber as shown in Fig. 4. Alternatively, the temperature could be too low, leading to lack of BTEX or ammonia destruction, and catalyst deactivation or plugging of the unit respectively.

Other examples that have proven added value are:

- Trending a slowly increasing waste heat boiler outlet temperature, correlated to the simulated temperature. An increasing temperature is an indication of fouling and the temperature at the outlet must stay below 340°C to prevent excessive corrosion and early failures. By trending this correlation, a turnaround can be scheduled with more accuracy.
- Catalyst life-time trending allows for planning catalyst replacement, only when the predicted performance is below required before reaching the next planned turnaround.
- More and more parameters can be correlated when analysing the data as well as improving the visualisation to highlight certain trends that provide insight into the health of the unit.

Some of the learnings from the first practical applications of Comprimo Insight are as follows:

- Each customer is unique in many aspects – the software they use, the work processes, the organisation, IT demands, and also the type of sulphur recovery processes. This requires tools such as Comprimo Insight, which offer a high degree of flexibility. The standard methodology for data handling in the Worley cloud has been standardised, however the interface with the customer with respect to data sharing and data visualisation will need to be flexible due to the different infrastructures set up by their IT.
- The customer unit engineer counterpart typically has little experience with data-

INCREASE YOUR PROFITS WITH INTELLIGENT SOLUTIONS



Your challenge might be finding a dry bulk handling solution that ensures the profitable, sustainable growth of your business.

Our expertise can provide just that. A totally enclosed Bruks Siwertell solution that ensures operations are efficient, reliable, and free from dust and spillage.

bruks-siwertell.com

in

A PART OF BRUKS SIWERTELL GROUP

BRUKS Siwertell
BULK HANDLING & WOOD PROCESSING

CONTENTS

What's in issue 396

COVER FEATURE 1

Sulphur and acid in China

COVER FEATURE 2

North African phosphates

COVER FEATURE 3

Extending acid plant life

COVER FEATURE 4

Optimising SRU operation

SULPHUR
ISSUE 396
SEPTEMBER-OCTOBER 2021

BCInsight

Southbank House, Black Prince Road
London SE1 7SJ, England

Tel: +44 (0)20 7793 2567

Fax: +44 (0)20 7793 2577

Web: www.bcinsight.com
www.bcinsightsearch.com

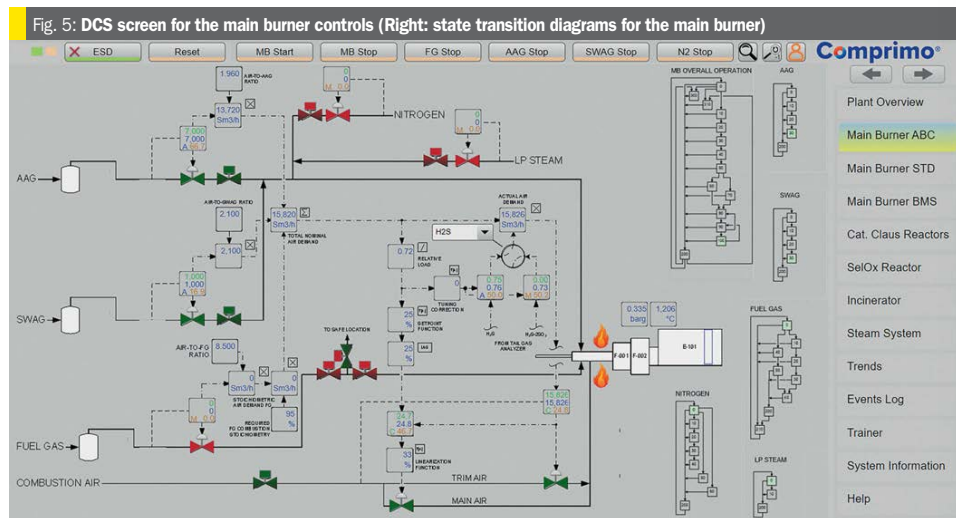

IMAGE: COMPRIMO

Quality Service



Sulphuric Acid – ChemTrans is your reliable Partner for supply, distribution and logistics.

CHEMTRANS 

ChemTrans Trading AG | Zugerstrasse 20 | P.O. Box 44 | CH-6314 Unterägeri
Phone +41 41 754 60 10 | chemtrans@chemtrans.ch | www.chemtrans.ch

sharing, cloud computing and difficulty in engaging the customer's IT. It has been Comprimo's experience that the biggest hurdle to overcome is support from the customer's information technology experts. This is more evident in small sized refining companies.

- The technology specialist must have a basic knowledge of cloud computing and have access to skilled IT people to set up and maintain the cloud systems. One of the main concerns that is brought from the customer is the cyber security of transferring data via the cloud. When one considers that credit card data is also processed in the cloud if purchasing goods in a webstore, this means that the cloud environment can be made very secure when using the right infrastructure, protocols, policies, and monitoring services.
- It is important to agree on who the owner of the data is and to formalise it in a contract. Preferably both parties are owners and free to use the data as needed within their own company.
- The data-sharing possibilities and cloud computing are evolving rapidly, and new features and services are developed all the time.
- It requires minimum effort to maintain the interface when using the right experts and tools for cloud computing and visualisations. There is a first-time investment required to discover and set

up the systems and infrastructure. With the large volumes of cloud computing employed around the world, the costs are relatively low and make it possible to develop monitoring services at very affordable fees.

- With Comprimo Insight, the customer's unit engineer and Comprimo's technology specialist have a better connection to discuss optimisation targets, upsets, or special operating scenarios. It is also a perfect interface to educate the customer's staff on the specifics of the licensed process.

Moving forward, Comprimo is looking at the further improvement of the data processing, which is currently done with Excel on a virtual machine in the Azure cloud. This solution will be upgraded soon using the latest technology, e.g., Azure Functions. Also, the visualisation needs focus to improve performance and especially using techniques that can load the data faster. Besides the mentioned outstanding improvements, it is important to realise that a certain minimum continuous effort will be needed to develop, improve, and use latest technologies to maintain the systems. Additionally, each customer has different requirements on how the data is delivered and over time the customer engineer may want to modify the visualisation to fit its needs better.

The dataset may be large enough to train the models for machine learning once data

has been flowing continuously for some years. It is expected that machine learning can have added value in preventing trips when data from upstream units, e.g., ARUs and SWSs, is available and when selecting the optimum setpoints for the reactor temperatures to meet e.g., SO₂ emission requirements at minimum steam consumption. When maintenance inspection results are included in the dataset, even predictive maintenance is on the horizon.

In summary, with Comprimo Insight it is now possible to share data in a secured environment and monitor and optimise licensed SRUs. Further improvement of the data processing and visualisation methodologies is ongoing. And it is expected that in the near future the harvested datasets can be used for further analysis and optimisation strategies, using the latest machine learning technologies.

Comprimo Immerse

Comprimo provides operator training for their licensed sulphur recovery units to customer operations and unit engineers. The theory of the sulphur recovery process and all specific features of the unit installed at the customer's facility are explained in detail. This includes attention to the details of equipment items and what is required during operation and a full explanation of the controls and safeguarding of the unit.

CONTENTS

What's in issue 396

COVER FEATURE 1

Sulphur and acid in China

COVER FEATURE 2

North African phosphates

COVER FEATURE 3

Extending acid plant life

COVER FEATURE 4

Optimising SRU operation

SULPHUR
ISSUE 396
SEPTEMBER-OCTOBER 2021

BCInsight

Southbank House, Black Prince Road
London SE1 7SJ, England
Tel: +44 (0)20 7793 2567
Fax: +44 (0)20 7793 2577
Web: www.bcinsight.com
www.bcinsightsearch.com

Fig. 6: Air control in MANUAL with change in AAG flow*

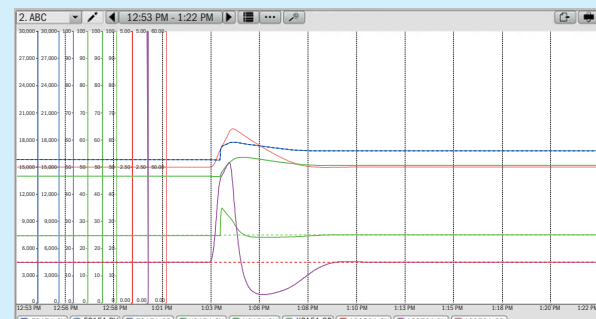

*blue: total air, green: main air opening, red: H₂S SP, pink: H₂S PV, light red: H₂S OP

Source: Comprimo

Fig. 7: Thermal oxidiser control response due to switching to SUPERCLAUS® operation*

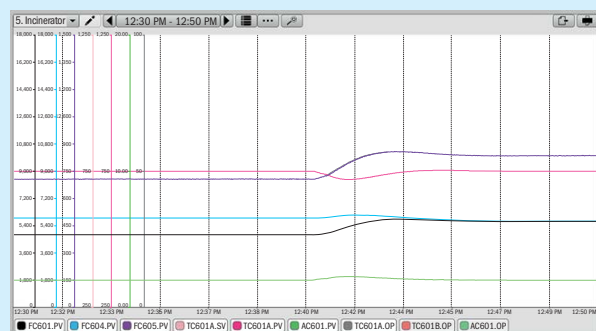

*black: primary air, blue:staged air, purple: FG, pink: temperature, green: O₂ content flue gas

Source: Comprimo

From experience, Comprimo realised that traditional classroom training did not cover all the dynamics of the process, especially the more complex loops like the burner controls which were quite difficult to get across so that they were fully understood by the audience. As a result, Comprimo developed an operator training simulator tool called Comprimo Immerse that allows a more dynamic approach to operator training.

Comprimo Immerse provides a simulation tool for an SRU (could be in a SUPERCLAUS® configuration or other tail gas technology) in which the key process controls are implemented (advanced burner

control, selective oxidation control, incinerator burner control), as well as the various safeguarding items (as per cause and effect diagram) and the start-up sequences with the required permissives.

The interface uses a representation of the DCS screens, with the various controllers showing setpoint (SP), process value (PV) and output (OP). It also shows in which mode the controller is operating (MANUAL/AUTO/CASCADE). This will give a clear overview and good representation of an SRU and of how the unit is controlled.

At first, Comprimo Immerse will be used to explain the controls in more detail

including the dynamics of the system, in which parameters are changing due to a variation in for example the feed gas flow. It is also possible to introduce a change in feed gas composition to monitor the behaviour and response of the system in case it is in fully AUTO-CASCADE control but also what the impact is in case a controller is not in the correct mode. Each step in the control can be explained and followed repeatedly, without any consequences to an actual operating unit. The worst scenario that can happen is the activation of the safeguarding system, which will stop the simulated burner (low low air flow to the burner activating closure of air supply and acid gas supply to the burner).

The tool is also used to explain the safeguarding of the unit by simulating specific scenarios such as low acid gas flow, low air flow or high H₂S content to the selective oxidation stage. As per the cause and effect diagram, each scenario has its consequences depending on the actual operating mode of the unit (e.g. the difference when the burner is operating on “acid gas only” versus “co-firing” mode). When an initiator is activated, the required actions are taken by the system and the specific on/off valves are closed (like in a real unit).

When a good understanding of the controls and safeguarding is achieved, the next step is to explain the different sequences applied nowadays within the Comprimo SRU designs. For example, the ignition sequence of the thermal oxidiser burner is fully automated from purging of the burner up to the admission of fuel gas into the burner and successful ignition. The system check for the required permissives is part of the tool, so that a full understanding of the sequences and permissives is achieved as well.

Included in the tool is the ability to create trends of the various parameters. This means that the behaviour can be monitored as a function of time as well (as is done with a real unit to monitor the operation and analyse the behaviour of the system).

This gives operations detailed insight of the behaviour of the system and adds to the understanding of how the unit can be operated and controlled.

Comprimo Immerse can be integrated as part of the customised training where the theoretical training material is combined with the dynamic simulation tool for further explanation.

During the training, it is possible to schedule time to allow operations to bring in scenarios that they have come across

which can then be simulated to see different responses and reactions on how it could potentially be handled better in the future.

All of this can be done in a safe environment disconnected from the real unit with freedom to play with the system.

The Comprimo Immerse tool can also be made available to the customer after the operator training, so that operations can continue working within the simulated environment. This will help to improve their understanding of the system and gain further confidence in the actual controls.

An example of how the Comprimo Immerse tool could be used to monitor the response of the control system is provided below. Fig. 6 shows the graphs of the trends taken during an upset situation of the plant.

The main burner was operating on AAG and SWAG with the tail gas H₂S concentration at a stable level. The SUPERCLAUS® stage was also in operation. By mistake, the total air controller was switched to MANUAL. As long as the unit was operating with a stable feed flow and composition, this would have no further consequences.

At around 13:02, the AAG flow to the main burner was increased from 7,000

Sm³/h to 7,500 Sm³/h. As the air supply was in MANUAL and thus did not follow the change in feed gas flow, the H₂S content in the tail gas showed a very rapid increase after about two minutes. Within one minute, the H₂S content exceeded already 2 vol%. In the meantime, the operator was notified that something was not normal. He noticed the air control in MANUAL and switched it back to CASCADE. This gave a shot of air to the burner. With the increase in H₂S, the analyser controller started to increase its output as more air was required by the system. When the H₂S started to drop, the controller started to reduce its output again.

The thermal oxidiser was operating with all controls in the correct mode (AUTO-CASCADE) at a temperature of 750°C. After achieving stable operation on the main burner as well as on the thermal oxidiser, the SUPERCLAUS® stage was taken into operation. As a consequence, the amount of combustibles in the tail gas to the thermal oxidiser were reduced. This resulted in a requirement to increase the fuel gas flow to the thermal oxidiser to maintain the required temperature. With the increase of fuel gas flow, the air flow to the burner was increased automatically as well.

Conclusion and future outlook

Comprimo Insight and Comprimo Immerse add a comprehensive service to sulphur recovery operations. A combination of the two tools can be used to improve the understanding of the unit as well as provide the opportunity to work with the licensor to optimise the performance of the unit. Comprimo Insight provides real-time ability to address operating issues with the licensor and clear and accurate monitoring of the unit. Comprimo Immerse provides the ability to improve the training methods available to the operators currently, as well as the option to expose them to non-routine operating scenarios in a safe environment. By using the Comprimo Immerse simulation tool, new operators can be trained more effectively, and experienced operators can get refresher training by using an interactive tool that can mimic operationally experienced situations.

Reference

1. Hydrocarbon Engineering, “The quest for a digital revolution”, February 2020.

ACID MIST WET ELECTROSTATIC PRECIPITATORS



Remove submicron PM, acid mist and heavy metals from:

- Roasters
- Smelters, Furnaces
- Incinerators
- Boilers
- Tail gas FGD Scrubbers



SCAN HERE with your Smart Phone for more info from Beltran



Beltran Acid Mist WESP, the proven design worldwide for:

- Ultralow emission for submicron particulate and acid mist
- Modular design- minimized field assembly, flexible configuration
- Available in corrosion-resistant alloys or FRP construction



Beltran Technologies, Inc.
1133 East 35th Street, Brooklyn, NY 11210
718.338.3311 • Fax: 718.253.9028
info@beltrantechnologies.com
www.beltrantechnologies.com

50 YEARS EXPERIENCE. MORE THAN 1000 INSTALLATIONS WORLDWIDE.
WE INVITE YOU TO JOIN US AS WE ENGINEER THE FUTURE IN EMISSION CONTROL TECHNOLOGY!

CONTENTS

What's in issue 396

COVER FEATURE 1

Sulphur and acid in China

COVER FEATURE 2

North African phosphates

COVER FEATURE 3

Extending acid plant life

COVER FEATURE 4

Optimising SRU operation

SULPHUR
ISSUE 396
SEPTEMBER-OCTOBER 2021

BCInsight

Southbank House, Black Prince Road
London SE1 7SJ, England
Tel: +44 (0)20 7793 2567
Fax: +44 (0)20 7793 2577
Web: www.bcinsight.com
www.bcinsightsearch.com

Ammonium salt formation conditions based on measured vapour pressures

ASRL has conducted studies on ammonia destruction in the sulphur recovery unit (SRU) for over a decade¹⁻⁵. Other studies at ASRL have investigated mechanisms for ammonium salt formation and deposition downstream in the Claus plant, as well as the potential sources of ammonia (NH₃) in a gas plant⁷. A less understood subject is addressing how much residual NH₃ is tolerable or at what temperature will residual NH₃ cause ammonium salt deposition. In this study, existing knowledge on thermal stability of ammonium salts and new measurements have been used to identify the gaseous components required for deposition, through reversible vapour pressure expressions.

M. Madekufamba, K.L. Lesage, N. I. Dowling and R.A. Marriott, Alberta Sulphur Research Ltd (ASRL).

Ammonium sulphate ((NH₄)₂SO₄) is very stable and requires only small amounts of SO₃ to lead to deposition, even with small amounts of NH₃. A potential source of SO₃ is a malfunctioning acid gas reheater or a natural gas reheater (excess O₂ or poor mixing) leading to "lead chamber cycle" chemistry involving NO₂⁶. Other gaseous species could lead to the formation of ammonium salts, albeit at cooler temperatures than anticipated. With this knowledge, this work sought to determine the levels of ammonia necessary for the formation of various ammonium salts and further study the gaseous species in equilibrium with some common salts.

As expected, measured vapour pressure data showed that ammonium sulphate vapour pressure was very low, suggesting that the salt can easily be formed below 250°C and is quite stable. Again, the stability of ammonium sulphate means that very low concentrations of ammonia can lead to direct precipitation if any SO₃ is present. Ammonium sulphite

on the other hand was found to be very unstable over 70°C, which suggests that it will not form in Claus conditions. Ammonium thiosulphate (NH₄)₂S₂O₃ was found to be the most likely species to be formed in the absence of SO₃ and below 150°C based on the measured vapour pressures. Note that subsequent formation of ammonium sulphate proceeds through the reaction between the H₂O and thiosulphate, thus discovery of ammonium thiosulphate or ammonium sulphate in or downstream of an SRU can be evidence for initial thiosulphate deposition from SO₂, H₂O and NH₃. Here the thiosulphate requires cold temperatures for initiation (83 to 98°C).

Ammonium salt deposition in Claus plants

In a refinery, ammonia will come from the hydrotreaters and is often sent with H₂S (sour water stripper gas) to the front end of the thermal reactor in a Claus plant. Claus plants designed for ammonia destruction convert the majority of the ammonia to

N₂. Incomplete ammonia destruction is thought to lead to deposition of ammonium salts downstream of the thermal reactor in the SRU; however, how much residual NH₃ is required to cause issues is often not clear. Furthermore, it's not just NH₃ that leads to a salt issue. Some SRUs seem to operate successfully with 150 ppmv of NH₃ while others do not.

As expected, the colder surfaces are where salts will deposit, thus evidence of deposition has been typically seen on the demister pads in the last condenser and in lines leading to the thermal oxidiser (Fig. 1). In a gas plant, sources of ammonia are not well understood, and suggestions have included the amine degradation in gas sweetening units or amine carry over to the Claus plant. ASRL has done some work to show that rates of ammonia formation in amine units are too low to account for ammonium salts found in some gas plants⁷.

Ammonium salt formation in Claus plants is difficult to predict given the fact that ammonia levels ranging from 40 to

Fig. 1: Ammonium salts and S₈ deposited on a demister pad

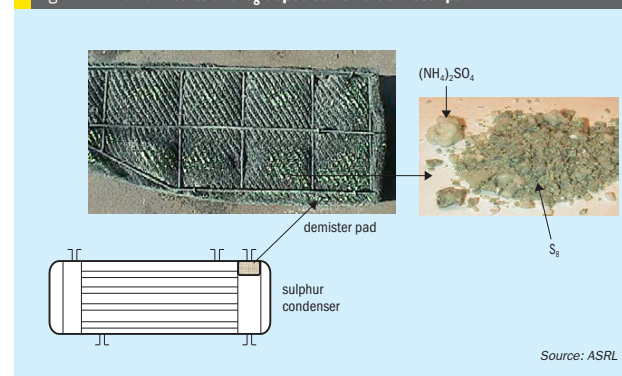

more than 150 ppm have been detected in some gas plants (both DEA and MDEA systems) with no deposition issues; however, some plants experience ammonium salt deposition. The question then remains how much ammonia causes issues with salt deposition and what is the mechanism of formation of these salts (what other species are required). Even more important is the question of whether one can rely on accurate salt vapour pressure to predict the possibility of ammonium salt deposition in a Claus environment.

In order to examine the potential deposition of ammonium sulphate, it is also important to consider the sulphuric acid dew point in a Claus plant^{8,9}. Sulphuric acid can be the precursor acid for the formation of ammonium sulphate. The vapour pressure indicates that ~1 ppm SO₃ would cause acid liquid to form at 130°C. Note that SO₃ is not stable under the thermal reactor temperatures, in particular under reducing conditions in the Claus reactor⁶. Sulphuric acid vapour pressure is greater than the vapour pressure of the ammonium sulphate salt; therefore, sulphuric acid is not considered a condensable product in

the presence of ammonia although it could be an intermediate material.

Existing literature data on the thermal stability of ammonium oxy-sulphur compounds at atmospheric pressure (Table 1) shows that ammonium sulphate is the most stable salt below 250°C¹⁰⁻¹². It also suggests that this would be the most stable salt to be deposited downstream of the thermal reactor in a sulphur plant. The mechanism for the formation of the ammonium sulphate and what levels of ammonia would be sufficient to cause deposition are poorly defined, because of the scarcity of the counter ion.

Ammonium salt deposition through a mechanism involving both the sulphate and thiosulphate species as part of the H₂S/SO₂ chemistry in the Claus process in both the gas phase and catalytic converters was identified by Clark and others (2006). The same study also demonstrated that SO₃ formation is not a prerequisite for ammonium salt deposition at the cooler temperatures. Note that several projects at ASRL have demonstrated the formation of ammonium thiosulphate as the most prevalent species below 230°C

Table 1: Decomposition temperatures for ammonium salts¹⁰⁻¹³

Compound		Decomposition temperature (1 atm)
(NH ₄) ₂ SO ₄	sulphate	235-280 °C
NH ₄ HSO ₄	bi-sulphate	< 235-280 °C
(NH ₄) ₂ S ₂ O ₃	thiosulphate	150 °C
(NH ₄) ₂ SO ₃	sulphite	60-70 °C
NH ₄ HSO ₃	bi-sulphite	< 150 °C (subl. in N ₂ at 150 °C)
NH ₄ NH ₂ CO ₂	carbamate	40 °C

(without SO₃ in the system). This is not to say that ammonium sulphate would not deposit directly if SO₃ were available after the waste heat boiler, so we need to pay attention to both mechanisms.

The equilibrium decomposition of ammonium sulphate was investigated by Kiyoura and Urano (1970), using differential thermal analysis (DTA), thermogravimetric analysis (TGA), chemical analysis and X-ray diffraction technique, from 140°C to 240°C¹³. Several possible intermediate species were identified and several steps proposed for the decomposition. The two-step decomposition is given in Reaction 1 with the overall equilibrium expression given by Equation 2.

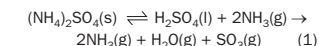

$$K_p = (P_{NH_3})^2 P_{H_2O} P_{SO_3} \quad (2)$$

Ammonium sulphite decomposition equilibrium was investigated by Scargill (1971), utilising chemical analysis and IR spectroscopy to identify chemical species while the dissociation equilibrium was derived from the transpiration method. Reaction 3 shows the reversible decomposition for the anhydrous salt. The equilibria shown by Scargill (1971), was based on experimental measurements from 0 to 23°C¹⁴

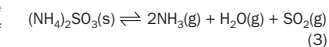

$$K_p = (P_{NH_3})^2 P_{H_2O} P_{SO_2} \quad (4)$$

The ammonium thiosulphate decomposition reaction can be expressed as a two-step process shown as Reactions 5 and 6. This work seeks to verify the equilibrium species that exist in detectable quantities for this system based on mass spectrometric analysis and quantification of condensed sulphur left behind by CS₂ solubility.

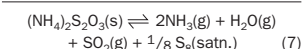
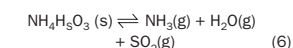
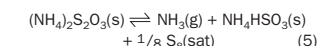

$$K_p = (P_{NH_3})^2 P_{H_2O} P_{SO_2} \quad (8)$$

With previous knowledge about the thermal stability of the various ammonium salts, this work was designed to determine the lower limits (temperature and concentrations) over which the salts can deposit and

the gaseous species involved in the equilibria. The experimental approach taken was to measure vapour pressure data that can be used to estimate deposition conditions. The use of cold trapping techniques to measure vapour pressure have been used in literature and it was also employed in this work. Its accuracy relies on the efficiency of the trapping media and how well the deposited salt can be recovered and analysed. It is limited by the fact that a few components can be analysed. Results obtained from the trapping technique for ammonium sulphate were not very accurate compared to available literature data. GC and MS techniques gave more accurate results which are presented in this work.

Ammonium sulphate vapour pressure and deposition

Literature data gives a wide decomposition temperature range for ammonium sulphate between 235-280°C (Table 1). Accurate values of the equilibrium constants for the reversible decomposition of the salt would be useful to calculate vapour pressure at any given set of temperature and pressure. In ASRL's work, decomposition of ammonium sulphate (Reaction 1) was measured at T = 200°C to 250°C using direct injection GC-TCD.

The experimental data together with literature data¹³ were used to fit an expression for the equilibrium constant (K_c), Equation 9 (T is in Kelvin):

$$K_c = \frac{(P_{NH_3})^2 P_{H_2O} P_{SO_2}}{(RT)^5} = e^{-a/b} \quad (9)$$

Fig. 2 is a graphical representation of the ammonium sulphate equilibrium as a function of temperature which shows that the data obtained in this work is in good agreement with existing literature data. The results presented in Fig. 2 illustrate that the ammonium sulphate equilibrium constant is very small. Based on the sulphuric acid dew point calculations, it would mean that under normal operating conditions, very low levels of ammonia and SO₂ would lead to ammonium sulphate deposition in all three converters before the condensation of sulphuric acid. For an example calculation, according to this low vapour pressure, 150 ppm NH₃ and 0.40 atm H₂O at T = 130°C would lead to formation of solid ammonium sulphate with just 3x10⁻¹⁹ atm SO₂. In another example, 150 ppm NH₃, 1 ppb SO₃ and 40% H₂O shows

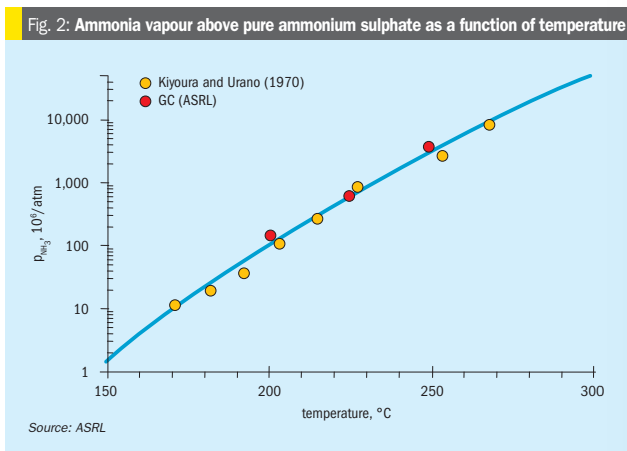

a solid formation temperature (saturation) at T = 191.4 °C.

This suggests that deposition will be an issue with low levels of ammonia if SO₃ is added to the SRU. Again, this can come about through direct fired reheaters which are operating with enough O₂ to generate SO₃ or with poor mixing (lead chamber chemistry). Note that this implies that the ammonium sulphate formation does not have to involve the condensation of sulphuric acid or SO₄²⁻, although the acid may be an intermediate species. This is particularly true if any sulphurous acid is condensed, where disproportionation can lead to small amounts of sulphate.

Ammonium sulphite vapour pressure

Decomposition of ammonium sulphite was measured using GC-TCD. Ammonium sulphite was not stable above 70°C. Tests were conducted on the hydrated salt (NH₄)₂SO₃·H₂O, for which the decomposition was assumed to follow Reaction 10.

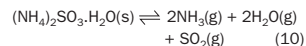

The corresponding equilibrium equation determined from ASRL results and literature data (Scargill, 1971)¹⁴ is:

$$K_c = \frac{(P_{NH_3})^2 (P_{H_2O})^2 P_{SO_2}}{(RT)^5} = e^{-a/b} \quad (11)$$

Results obtained in this work agree with literature data within experimental uncertainty¹⁴. This is consistent with the low decomposition temperature and ambient

pressure reported in literature. The equilibrium constant for ammonium sulphite shows that low levels of ammonia could deposit ammonium sulphite below 60°C; however, this is below the sulphurous acid and/or water dew point in the system. Thus, ammonium sulphite is not likely to be a depositable species in the SRU.

Ammonium thiosulphate vapour pressure

The decomposition of ammonium thiosulphate was followed using mass spectrometry from 60°C to 120°C while analysing all gaseous components. The species analysed included SO₃, H₂S, SO₂, NH₃ and H₂O and S₈. Fig. 3a shows MS results plotted as raw detector counts, with increasing levels of H₂O, NH₃ and SO₂ from 70°C to 120°C. The small deviation from the theoretical SO₂:H₂O ratio of 1:1 is because of the use of raw mass counts on the graph. The average ratio of SO₂:NH₃ from measured gas concentration above 80°C was 2.05 ± 0.02. In order to show what is happening below 70°C, Fig. 3a has been replotted as Fig. 3b with a logarithmic axis to focus on the low intensity peaks. A low signal-to-noise ratio below 200 minutes (T < 90°C) was observed. Also evident from Fig. 3b is evidence of low levels of H₂S, which increase up to 120°C. There was no measurable level of SO₃ in the system. There was visual evidence of S₈ build up (seen as a yellow colour) on the ammonium thiosulphate bed. Formation of significant levels of SO₂, NH₃ and H₂O and S₈ supports the applicability of Reaction 7 as the reversible decomposition or formation

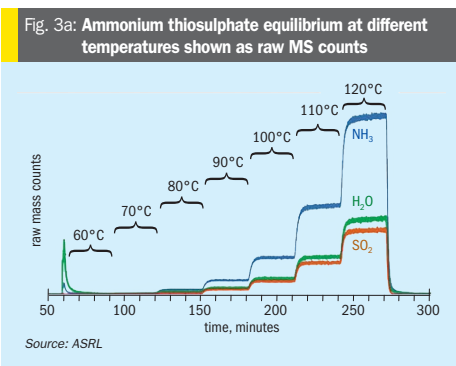

reaction for ammonium thiosulphate. The corresponding calibrated equilibrium expression for reversible decomposition of ammonium thiosulphate is given by Equation 12.

$$K_c = \frac{(P_{NH_3})^2 P_{H_2O} P_{SO_2}}{(RT)^4} = e^{-a/b} \quad (12)$$

Only experimental data above 90°C (two independent sets of data) were used to calibrate Equation 12. The results together with calibrated equation are graphically presented in Fig. 4. The thiosulphate equilibria shown in Fig. 4 were highly reproducible as shown by both the duplicate set of results for ammonia vapour pressure as well as the results derived from the SO₂ measurements.

By considering the presented vapour pressure data, ammonium thiosulphate is

the most likely salt to be formed in cold sections of the SRU when SO₃ is not present. Before exploring some deposition conditions, ASRL wanted to verify that other species in the SRU would not influence this equilibrium. Additional experiments were conducted to explore the equilibrium shift on addition of different species to the thiosulphate system. Low levels of H₂O, H₂S, SO₂ and NH₃ were added to the system as individual gas mixtures balanced with nitrogen. The H₂O, SO₂ and NH₃ additions shifted the equilibrium in line with Le Chatelier's principle of disturbing a dynamic equilibrium. Both H₂O, SO₂ lowered NH₃ partial pressure and NH₃ addition lowered SO₂ partial pressure. Addition of H₂S proceeded to generate more sulphur from the Claus reaction with SO₂. Fig. 5 shows the decreased SO₂

signal on addition of H₂S to the system, as well as an increase in the H₂O level consistent with the Claus reaction.

Separate experiments conducted at 120°C while flowing N₂ over the solid, were conducted to verify the thiosulphate decomposition reaction through the S8 mass balance. The mass of sulphur collected at the end of test was within 97% of that obtained from the measured moles of SO₂. This supports the ratio for 1 SO₂ : 1/8 S₈ in Reaction 7.

Note that ammonium thiosulphate reacts with H₂O to form the more stable sulphate salt:

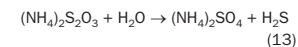

In other furnace studies carried out at ASRL, with partial destruction of NH₃ and intentional trapping at T > 80°C, significant amounts of ammonium thiosulphate salts have been found. After some time, these salts can show up as a mixture of the thiosulphate and sulphate salt. Thus, finding ammonium sulphate in a SRU could be due to either ammonium thiosulphate deposition, followed by sulphate formation, or direct ammonium sulphate formation in the presence of SO₃. Note that a transient event, leading to a finite amount of either salt, could lead to an unexpected trapping of liquid water and/or higher insulating behaviour for internal surfaces.

Thus far, equilibria expressions 9, 11 and 12 have been presented for calculating solid formation temperatures or maximum concentrations for ammonium sulphate, sulphite and thiosulphate. Where most simulations rely on Gibbs Energy Minimisation (GEM) routines for complex equilibria in the SRU, ASRL

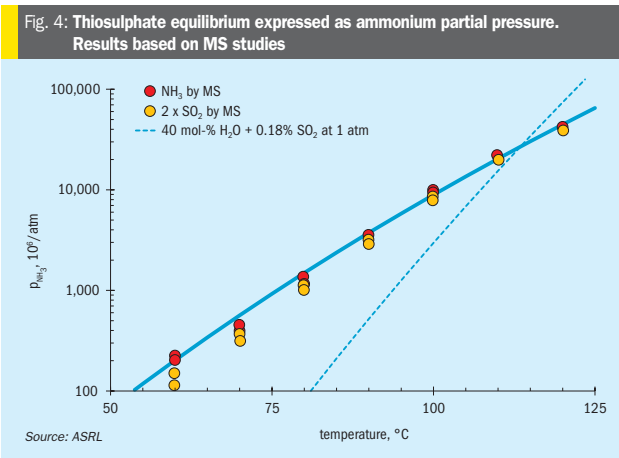

CONTENTS

What's in issue 396

COVER FEATURE 1

Sulphur and acid in China

COVER FEATURE 2

North African phosphates

COVER FEATURE 3

Extending acid plant life

COVER FEATURE 4

Optimising SRU operation

SULPHUR
ISSUE 396
SEPTEMBER-OCTOBER 2021

BCInsight

Southbank House, Black Prince Road
London SE1 7SJ, England
Tel: +44 (0)20 7793 2567
Fax: +44 (0)20 7793 2577
Web: www.bcinsight.com
www.bcinsightsearch.com

integrated Equations 9 and 12 into the gas phase GEM simulations which also incorporate gaseous sulphuric acid. This allows to solidification to be explored under various Claus conditions.

ASRL explored several configurations using a 90/10 acid gas + sour water stripper gas [1:1] and 150 ppm of undestroyed NH_3 . For a standard three-stage Claus at a 2:1 ratio, ASRL calculated a solid ammonium thiosulphate salt formation temperature at 84°C. This formation temperature increased to 89°C with 100% oxygen enrichment. All of these temperatures are below the surface temperatures within a well designed and well operating sulphur plant. The one exception could be the final flow line to the thermal oxidiser, where salt deposition has been noted in the past. Note that an 8:1 ratio dropped the solid formation temperature by 20°C.

It is possible that under an upset condition, the SRU may see 2% SO_2 . In this case, the formation temperature with 150 ppm NH_3 would be 90°C. Finally, if under upset condition, the total SRU pressure increases to 2 atm, then the salt formation temperature would be 98°C. All of these scenarios require quite low temperatures.

Finally, ASRL explored how much NH_3 could be tolerated at 2% SO_2 and 40% H_2O and reasonable operating cold temperature of 130°C. In this case 10% (100,000 ppm) NH_3 would be required for deposition. In other words, if there is no SO_3 , eliminating cold spots should mitigate ammonium salt deposition. Based on these exploratory numbers, one can expect that the majority of salt deposition issues are caused by SO_3 forming ammonium sulphate due to malfunctioning fired reheaters; however, deposition in very cold spots can still be initiated with just SO_2 and H_2O at 84 to 98°C.

Conclusions

Where ammonia is not completely destroyed in the front-end thermal reactor of a Claus plant, residual NH_3 can lead to ammonium salt deposition under the right conditions. In order to gain a better understanding of appropriate deposition conditions, vapour pressure compositions have been measured for pure ammonium sulphate $[(\text{NH}_4)_2\text{SO}_4]$, sulphite $[(\text{NH}_4)_2\text{SO}_3]$ and thiosulphate $[(\text{NH}_4)_2\text{S}_2\text{O}_3]$. From these measurements, vapour pressure expressions have been presented for exploratory calculations and incorporation into ASRL's GEM simulation

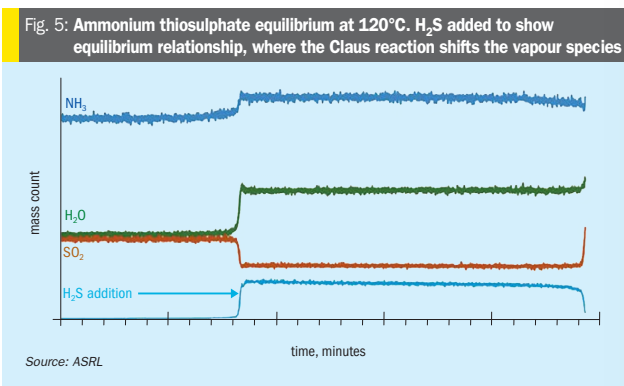

routines. ASRL's study has found that virtually any SO_3 in combination with any amount of NH_3 will thermodynamically result in direct formation of ammonium sulphate salt. If SO_3 is not present, then ammonium sulphate can form by first solidifying ammonium thiosulphate on surfaces at 84 to 98°C, given 150 ppm NH_3 and various quantities of SO_2 . Ignoring deposition kinetics, ammonium thiosulphate at these temperatures would also coprecipitate with sulphur. Thus, either significantly cold surfaces or the introduction of SO_3 can result in ammonium salt formation. At 130°C, ASRL experiments suggest that SO_3 would be needed to form ammonium salt in the SRU.

Well designed and robust front end thermal reactors, acid gas reheaters and fuel gas reheaters should avoid the production of SO_3 through lead chamber chemistry. If faced with ammonium salt deposition, elimination of cold spots should coincide with the elimination of any source of SO_3 . Future work could be aimed at investigating the fate of SO_3 after passing through the Claus converters, where it is not known if all SO_3 would survive these beds.

References

- Marriott, R.A., Li, D., Prinsloo, R., Dowling, N.I. and Clark P.D.: "Understanding ammonia destruction in the Claus furnace", Sulphur 2017, Atlanta, USA (2017).
- Clark, P.D., Dowling, N.I., Huang, M.: "Mechanisms of ammonia destruction in the Claus front-end furnace, ASRL Quarterly Bulletin, Vol XXXIV, No. 4, pp. 1-50 (1998).
- Clark, P.D., Dowling, N.I., Huang, M.: "Further comments on the destruction of ammonia in the Claus reaction furnace, ASRL Quarterly Bulletin, Vol XXXVI, No. 1, pp. 48-93 (1999).
- Clark, P.D., Dowling, N.I., Huang, M., Marriott, R.A.: "the chemistry of ammonia decomposition in the Claus furnace, ASRL Quarterly Bulletin, Vol LII, No. 2, pp. 41-55 (2015).
- Clark, P.D., Dowling, N.I., Huang, M.: "Preliminary kinetic analysis of NH_3 destruction in Claus furnace: Reaction orders, rate constants, activation energies and frequency factors of relevant reactions", ASRL Quarterly Bulletin, Vol LI, No. 3, pp. 47-74 (2014).
- Clark, P.D., Dowling, N.I., Huang, M., Bernard F. and Lesage K.L.: "Deposition of ammonium salts in Claus systems: theoretical and practical considerations", ASRL Quarterly Bulletin 136 Vol. XLII No.4, January - March 2006, pp.1-34. Brimstone Sulfur Recovery Symposium, Vail, Colorado, USA (2006).
- Madekufamba M., Mercer D., Chou N. and Marriott, R.A.: "Investigating ammonia formation from amine degradation under sour conditions at regenerator-reboiler conditions", LRGCC, Norman, OK (2020).
- Verhoff, F.H. and Banchemo, J.T.: "Predicting dew points of gases", Chemical Engineering progress 78 (8): 71 - 72 (1974).
- Pierce R.R.: "Estimating acid dewpoints in stack gases", Chemical Engineering 84 (8): 125 - 128 (1977).
- Handbook of Chemistry and Physics, 80th Ed., CRC Press, Inc., Boca Raton, Florida, USA (1999-2000).
- The Merck Index, 12th Ed., Merck and Co. Inc., Whitehouse Station, NJ, USA (1996).
- Aldrich Handbook of Fine Chemicals and Laboratory Equipment, Sigma Aldrich Fine Chemicals, Canada (2000-2001).
- Kiyoura, R. and Urano, K.: "Mechanism, kinetics, and equilibrium of thermal decomposition of ammonium sulfate", Ind. Eng. Chem. Process Des. Develop., Vol. 9, No. 4, 489-494 (1970).
- Scargill, D.: "dissociation constant of anhydrous ammonium sulphite and ammonium pyrosulphite prepared by gas-phase reactions", J. Chem. Soc. (A): Inorg. Phys. Theor., 2461-2466 (1971).



MOLTEN SULPHUR FILTER

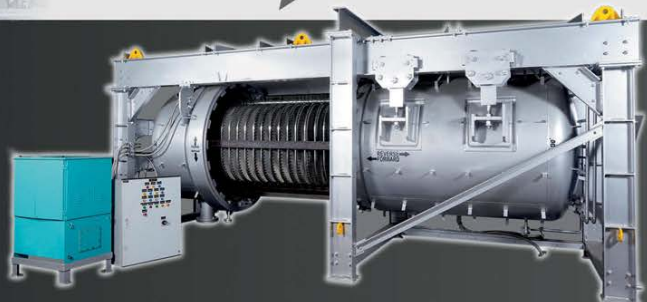

Advantages

- Quick opening and closing by hydraulic
- Full jacketed design of vessel
- 5 layer bolted leaf design can handle high pressure
- Large leaf spacing allows higher thickness of cake build up and permits easy cleaning
- Overhead frame design can be offered
- Scraper plates are provided to remove the residual molten sulphur from the inside of vessel
- More than 50 installations

Sharpex have supplied several filters for molten sulphur filtration in sulphuric acid & sulphonation plants. Sharpex offers horizontal pressure leaf filter for molten sulphur filtration in Shell retraction design and Bundle retraction design.

Both the versions are operated (for opening and closing of filter) hydraulically for easy of operation.

FILTRATION AREA
from 5 m² to 200 m²

FOR EFFECTIVE SULPHUR FILTRATION

CARTRIDGE FILTERS FOR SULPHUR POLISHING

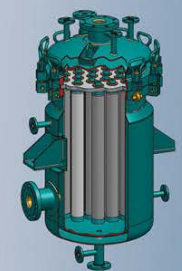

Cartridge type polishing filters are installed after main molten sulphur filters to remove traces of fine suspended particles ash and filter aids escaped from main filter, which may choke the downstream equipments in the plant. The removal of these fine solids will help in running the downstream equipments smooth without interruptions. This will result in reducing the downtime of the plant to great extent.

SHARPLEX FILTERS (INDIA) PVT. LTD.
R-664, T.T.C. Industrial Area, Thane-Belapur Road, Rabale, MIDC, Navi Mumbai - 400701, India; Tel : +91-91-3692 1232/39, +91-22-27696339/6322/6325. E-mail : sales@sharpfilters.com
Website : www.sharplex.com



- CONTENTS
- What's in issue 396
- COVER FEATURE 1
- Sulphur and acid in China
- COVER FEATURE 2
- North African phosphates
- COVER FEATURE 3
- Extending acid plant life
- COVER FEATURE 4
- Optimising SRU operation

SULPHUR
ISSUE 396
SEPTEMBER-OCTOBER 2021

BCInsight

Southbank House, Black Prince Road
London SE1 7SJ, England
Tel: +44 (0)20 7793 2567
Fax: +44 (0)20 7793 2577
Web: www.bcinsight.com
www.bcinsightsearch.com

Advertisers' index

Editor: RICHARD HANDS
richard.hands@bcinsight.com

Technical Editor: LISA CONNOCK
lisa.connock@bcinsight.com

Contributor: MEENA CHAUHAN
meena.chauhan@argusmedia.com

Publishing Director: TINA FIRMAN
tina.firman@bcinsight.com

Subscription rates:
GBP 440; USD 880; EUR 680

Subscription claims:
Claims for non receipt of issues must be made within 3 months of the issue publication date.

Sales/Marketing/Subscriptions:
MARLENE VAZ
Tel: +44 (0)20 7793 2569
Fax: +44 (0)20 7793 2577
marlene.vaz@bcinsight.com
Cheques payable to BCInsight Ltd

Advertising enquiries:
TINA FIRMAN
tina.firman@bcinsight.com
Tel: +44 (0)20 7793 2567

Previous articles from *Sulphur* from 1995 to the present are available digitally in PDF format. To make a purchase, or for a list of available articles, please see: www.bcinsight.com

Copyright:
Issued six times per year, or bi-monthly. All rights reserved. No part of this publication may be reproduced, stored in a retrieval system or transmitted in any form or by any means – electronic, mechanical, photocopying, recording or otherwise – without the prior written permission of the Copyright owner.

ISSN: 0039-4890

Design and production:
JOHN CREEK, DANI HART



Printed in England by:
Buxton Press Ltd
Palace Road, Buxton, Derbyshire,
SK17 6AE

© 2021 – BCInsight Ltd

BCInsight

Published by: BCInsight Ltd
China Works, Unit 102,
100 Black Prince Road,
London SE1 7SJ, UK
Tel: +44 (0)20 7793 2567
Fax: +44 (0)20 7793 2577
Web: www.bcinsight.com
www.bcinsightsearch.com

Advertiser	Page	Website
Argus Media	11	argusmedia.com
AXENS	9	axens.net
Beltran Technologies	55	beltrantechnologies.com
Berndorf Band Group	17	berndorfband-group.com
Blasch Precision Ceramics	15	blaschceramics.com
Bruks-Siwertell	51	bruks-siwertell.com
Chemtrans Trading	37	chemtrans.ch
CS Combustion Solutions GmbH	47	comb-sol.com
Desmet Ballestra SpA	21	desmetballestra.com
Dupont Clean Technologies	25	cleantechnologies.dupont.com
Haldor Topsoe	27	topsoe.com
HUGO PETERSEN GmbH	OBC	hugo-petersen.de
Industrial Ceramics	45	industrialceramics.com
IPCO Germany GmbH	5	IPCO.com
Sharpflex Filters	61	sharpflex.com
STEULER-KCH GmbH	13	linings.steuler.de
Sulphur + Sulphuric Acid 2021 Conference	IBC	crugroup.com
Sulzer Pumps	35	sulzer.com
Weir Minerals	31	global.weir/brands
Worley Chemetics	IFC /37	worley.com/chemetics

Next issue: November/December 2021

- Small scale desulphurisation processes
- Processing sour water stripping gas
- Trends in demand for sulphur fertilizers
- Sulphuric acid markets
- Review of the year

Closing date for advertisement space booking is 29 October 2021
For further information and to book advertisement space contact:
Tina Firman, Publishing Director: tina.firman@bcinsight.com
Tel: +44 (0)20 7793 2567 Fax: +44 (0)20 7793 2577

37th

CRU

Oil | Gas | Fertilizers | Metallurgy | Industrial Sulphur + Sulphuric Acid 2021 Virtual Conference & Exhibition

1-4 November 2021

STAY CONNECTED AND INFORMED - FROM YOUR PLANT, OFFICE OR HOME

CRU's **Sulphur + Sulphuric Acid** will run as a fully virtual event in 2021 – connecting you with an even wider audience of sulphur and acid industry professionals from around the globe.

Drawing on the success of the 2020 virtual event you can expect expanded content streams, enhanced networking opportunities and much more – all from the convenience of your plant, office or home.

The dual-stream technical agenda, covering technical updates on the production and processing of sulphur and sulphuric acid, will feature industry-leading presentations covering new innovations in process, technology, materials and equipment developments, as well as practical case studies highlighting operational experience and improvement.

600+
industry
professionals

250
operators

40+
exhibitors

44
countries
represented

30 HOURS
of presentations and
Q&A sessions -
live and on-demand

SPONSORS:



OFFICIAL PUBLICATIONS:



For more information or to book your place please visit:
www.sulphurconference.com

CONTENTS

What's in issue 396

COVER FEATURE 1

Sulphur and acid
in China

COVER FEATURE 2

North African
phosphates

COVER FEATURE 3

Extending acid
plant life

COVER FEATURE 4

Optimising SRU
operation

SULPHUR
ISSUE 396
SEPTEMBER-OCTOBER 2021

BCInsight

Southbank House, Black Prince Road
London SE1 7SJ, England
Tel: +44 (0)20 7793 2567
Fax: +44 (0)20 7793 2577
Web: www.bcinsight.com
www.bcinsightsearch.com

1
2
3
4
5
6
7
8
9
10
11
12
13
14
15
16
17
18
19
20
21
22
23
24
25
26
27
28
29
30
31
32
33

ADVANCING TOGETHER

HUGO PETERSEN
Your partner when it comes to sulphuric acid.



Don't forget the next
issue of **Sulphur**
November/December 2021



CONTENTS

What's in issue 396

COVER FEATURE 1

Sulphur and acid
in China

COVER FEATURE 2

North African
phosphates

COVER FEATURE 3

Extending acid
plant life

COVER FEATURE 4

Optimising SRU
operation

SULPHUR
ISSUE 396
SEPTEMBER-OCTOBER 2021

BCInsight

Southbank House, Black Prince Road
London SE1 7SJ, England
Tel: +44 (0)20 7793 2567
Fax: +44 (0)20 7793 2577
Web: www.bcinsight.com
www.bcinsightsearch.com



HUGO PETERSEN GmbH Tel. +49 (611) 962-7820
Rheingastrasse 190-196 Fax +49 (611) 962-9099
65203 Wiesbaden contact@hugo-petersen.de

WWW.HUGO-PETERSEN.DE

A subsidiary of
C·A·C
Chemicalanlagenbau Chemnitz GmbH