

1
2
3
4
5
6
7
8
9
10
11
12
13
14
15
16
17
18
19
20
21
22
23
24
25
26
27

Welcome to our interactive version of **Sulphur** Issue 394

Please use either the buttons on the left or top right of the page to navigate your way around this interactive PDF

IMPORTANT INFORMATION:

Copyright – Issued six times per year, or bi-monthly. All rights reserved. No part of this publication may be reproduced, stored in a retrieval system or transmitted in any form or by any means – electronic, mechanical, photocopying, recording or otherwise – without the prior written permission of the Copyright owner.

Number 394

May | June 2021

SULPHUR

www.sulphurmagazine.com



Sulphur market update

India's acid demand

SRU revamping

Wet gas cleaning

CONTENTS

What's in issue 394

COVER FEATURE 1

Sulphur market update

COVER FEATURE 2

India's acid demand

COVER FEATURE 3

SRU revamping

COVER FEATURE 4

Wet gas cleaning

SULPHUR
ISSUE 394
MAY-JUNE 2021

BCInsight

Southbank House, Black Prince Road
London SE1 7SJ, England
Tel: +44 (0)20 7793 2567
Fax: +44 (0)20 7793 2577
Web: www.bcinsight.com
www.bcinsightsearch.com



Decrease OPEX



Reduce emissions



Optimize capacity



Improve uptime



Energy efficiency

We are everything sulphur and much more

Comprimo and Chemetics – delivering sulphur and sulphuric acid solutions for a more sustainable world.

Through everything we do, we provide maximum long-term profits for our customers while meeting the most stringent environmental requirements. Helping our customers to be better neighbours is always good business for them and us.

Learn more with one of our experts
email: sulphursolutions@worley.com

Comprimo®

worley.com/comprimo

CHEMETICS

worley.com/chemetics



Cover: Wet gas cleaning plant, Mazidagi complex, Turkey. Metso Outotec.



10 Sulphur markets

Covid and project delays add to unpredictability.



16 Acid cooling

A novel technology provides a new approach to the cooling of strong sulphuric acid.

Read this issue online at:
www.sulphurmagazine.com

Published by:
BCInsight

SULPHUR

www.sulphurmagazine.com

NUMBER 394

MAY | JUNE 2021

CONTENTS

10 Sulphur markets remain unpredictable

While the covid pandemic has kept refinery run rates down in 2020, new refinery sulphur capacity will nevertheless form the bulk of new additions to sulphur production over the next few years. But delays to projects on both the supply and demand sides could tip a fairly balanced market in either direction.

12 Sulphur in India

India's growing economy and population are leading to increased demand for sulphur and sulphuric acid.

13 Sulphur recovery project listing

Sulphur's annual survey of recent current and future sulphur recovery unit construction projects.

14 The future of smelting in East Asia

Smelters in Japan and Korea have long been stalwarts of East Asian sulphuric acid production and export, but China's domestic capacity continues to rise rapidly.

16 A safer and efficient way to cool strong sulphuric acid

N. Clark, B. Avancini and V. Sturm of Clark Solutions discuss a novel technology, SAFEHX®, providing a new approach to the cooling of strong sulphuric acid. Prototype results are shown and indicate a safe and stable cost-effective technology. SAFEHX® can be extended to every heat exchanger system where corrosion, mixture risks, fouling, process liquid loss (or contamination) and temperature control are key concerns.

18 The key to acid quality and acid plant longevity

With declining ore grade feed to a metallurgical smelting process comes an increase in impurity load in the gas cleaning/acid process chain. K. Hasselwander, L. Skilling and C. Bartlett of Metso Outotec discuss a range of process solutions and how to maintain high productivity while keeping costs in check.

21 SRU revamping for emissions compliance and capacity increase

RATE discusses options for compliance with new regulations on emissions regarding IMO 2020 compliance and report on the results and evaluation of three case studies. Worley Comprimo reports on the revamp of a sulphur complex built in the late 1980s at a refinery in East Asia with the aim to increase the capacity, improve the availability and reliability and make the unit environmental compliant.

REGULARS

- 3 Editorial A difference of opinion.
- 4 Price Trends
- 5 Market Outlook
- 6 Sulphur Industry News
- 7 Sulphuric Acid News
- 9 People/Calendar

CONTENTS

What's in issue 394

COVER FEATURE 1

Sulphur market update

COVER FEATURE 2

India's acid demand

COVER FEATURE 3

SRU revamping

COVER FEATURE 4

Wet gas cleaning

SULPHUR
ISSUE 394

MAY-JUNE 2021

BCInsight

Southbank House, Black Prince Road
London SE1 7SJ, England

Tel: +44 (0)20 7793 2567

Fax: +44 (0)20 7793 2577

Web: www.bcinsight.com
www.bcinsightsearch.com

A difference of opinion

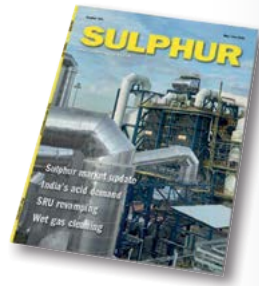

There is an old adage that if you put two economists in a room, you will get three different opinions. As the world enters its second year of dealing with the coronavirus pandemic, that certainly still seems to be the case among those grappling with predicting an increasingly uncertain world.

In early April, the International Monetary Fund (IMF) released its biannual World Economic Outlook (WEO), which revised its previous figures upwards by 0.5% in predicting that the global economy would grow by a record 6% in 2021, after an average fall of 3.3% in 2020 (though others put the fall closer to 4.5%). Yet just last week I saw a headline that told me: 'Why India's coronavirus crisis will derail the world economy'. The surge of cases and deaths in India appears to follow official complacency following a relatively successful handling of the first wave in 2020, and has taken the world by surprise and shock. The speed and scale of the return of the virus is a salutary warning that things can change very quickly if governments do not keep on top of cases.

There is also a noticeable bifurcation that has evolved globally between the way developed economies and emerging markets have weathered the storm. Last year, globally interconnected developed world countries were hit hardest by the virus, with average output falling 4.7% compared to 2.2% for emerging markets, but now the bifurcation appears to be moving the other way. We appear to be moving into a world of vaccine haves and have nots, while tourism money that used to boost economies like Thailand may take a long time to return. The US and China are expected to do well this year, with growth of 6.4% and 8% respectively, and to a lesser extent Western Europe at 4.4%, with emerging markets growth (ex-China) put at 4-6%, depending upon who you believe, but the US is now struggling with vaccine hesitancy that may make achieving herd immunity difficult. Meanwhile, every week of bad news from India revises figures downwards, and the downside risks for global trade are based around already developing trends of protectionism that might only be accelerated by vaccine nationalism. Longer term, the IMF predicts that while developed economies may reach 2024 only 1% down on pre-pandemic predictions, for developing economies that figure may be 4-8% down, as they take longer to deal with the impact of the pandemic and are unable to afford the job furlough schemes and stimulus packages

that richer countries can. Oil market demand, itself driven by growth in emerging markets, may also take longer to return than had been initially anticipated. For developed economies, levels of unemployment and debt may still be a drag on economies for some years.

For the primary processing industries that dominate the sulphur and sulphuric acid markets, the headline figure is that global foreign direct investment (FDI) was down 42% in 2020, and global trade fell by nearly 10%, while FDI predictions for 2021 could see another 5-10% contraction. The effects of this may take a couple of years to make themselves felt, as inventories take some of the strain in the interim, but are sure to cause further disruptions and dislocations further down the line. Some markets are already feeling the pinch. Phosphate demand continues to be strong while some sulphur generating projects continue to be delayed. In Europe, lack of refinery sulphur availability due to continued lockdowns and reductions in commuting has impacted upon sulphuric acid availability, helping to increase acid prices globally even though copper markets are booming to such an extent that Chinese refiners cannot source enough concentrate. The copper concentrate shortage should ease as new mines expand this year and next, but of course covid could still throw a spanner in that prediction. Meanwhile, India has been a major buyer of acid for phosphate production, but as the pandemic worsens there, calls are growing for a national lockdown similar to the one it undertook in April 2020, which saw phosphate operations badly disrupted for a couple of months.

If the copper market is anything to go by, the IMF may be right about 2021. Metal traders sometimes refer to it as 'Dr Copper', as the metal seems to have a PhD in economics, being a reliable leading indicator of economic health and anticipated consumer demand. Let's hope so. ■

Richard Hands, Editor



End-to-end systems from receipt of molten sulphur to loading of solid material – single source supply by IPCO.

- Premium Rotoform pastillation.
- Duplex steel belts specifically alloyed to resist corrosion.
- High capacity drum granulation.
- Downstream storage – silo and open/closed stockpiles.
- Custom-built reclaimers for any location.
- Truck, rail and ship loading and bagging systems.
- Large scale block pouring.



CONTENTS

What's in issue 394

COVER FEATURE 1

Sulphur market update

COVER FEATURE 2

India's acid demand

COVER FEATURE 3

SRU revamping

COVER FEATURE 4

Wet gas cleaning

SULPHUR
ISSUE 394
MAY-JUNE 2021

BCInsight

Southbank House, Black Prince Road
London SE1 7SJ, England
Tel: +44 (0)20 7793 2567
Fax: +44 (0)20 7793 2577
Web: www.bcinsight.com
www.bcinsightsearch.com



MARKET INSIGHT

Meena Chauhan, Head of Sulphur and Sulphuric Acid Research, Argus Media, assesses price trends and the market outlook for sulphur.

SULPHUR

The global sulphur market was focused on second quarter contract negotiations in April, with the final stages progressing by the middle of the month. As expected, confirmed agreements firmed by almost three figures on last quarter as settlements reflect the first-quarter rally in spot prices. But the recent plateauing and slight softening in global spot prices throughout March has raised tensions between the buy and sell sides, as parties struggle to reach agreement on where prices should settle.

The Tampa molten contract was agreed in early April and set the precedent for second quarter contracts, settling at \$192/t c.f.r. – a rise of \$96/t on the previous quarter. Spot availability out of the US Gulf has been tight in recent months but there were hints of improvement as refinery run rates have been improving. Spot pricing was assessed by Argus at \$193-199/t f.o.b. in mid-April although few sales have tested the price recently. The vaccine rollout in the US has been largely successful and traveller numbers were more than 10 times higher than in the first lockdowns a year earlier in April. Rising fuel demand is positive for refining margins and expectations are to see the some easing in market tightness for sulphur as a result through the second quarter onwards.

On the demand side in the US, processed phosphates sector-based consumption remains healthy following duties imposed on Moroccan and Russian imports. Nola DAP prices softened to just under \$540/t f.o.b. in mid-April from a high of \$562/t f.o.b. at the start of April.

The supply situation in Western Europe remains one of the tightest globally. The pandemic has held refinery run rates at minimal levels and further closures have removed further sulphur supply. Preliminary deals for second quarter molten contracts for Benelux were penned at \$190/t c.f.r. and others heard potentially settling above \$200/t c.f.r. The supply situation has become so stretched that one European buyer took delivery of a molten cargo from the Middle East – the first time this is understood to have occurred. Molten product from Tampa, US is also making its way to European customers.

Brazil is expected to take most product for the second quarter from the FSU, and some product had already been secured at \$213-214/t c.f.r. Middle East suppliers were looking to settle in the mid-\$180s/t f.o.b., above the price range targeted by Brazilian buyers when freight is considered.

Contracts for north African delivery were expected to settle in the range of \$187-225/t c.f.r. with Moroccan processed phosphates producer OCP securing larger cargoes at the low end and Tunisian oftakers settling at the high end.

As contracts finalise, volatility has decreased in the spot market and prices continue to soften slightly across most regions. Demand from China has now softened as the domestic phosphates season is almost at an end. This has left India as the main c.f.r. market supporting f.o.b. prices in the Middle East. Easing freight rates and the arrival of cheaper Turkmen product from the Black Sea have also helped soften major c.f.r. benchmarks, but the sustainability of these cargoes

has come into question as barge availability remains scarce, slowing transit times.

As spot liquidity wanes, India has been supporting Middle Eastern prices. The Indian processed phosphates market is preparing for the upcoming kharif season and is securing DAP for application. The fundamentals are supportive of strong sulphur demand – high phosphoric acid and sulphuric acid import prices remain unworkable for most phosphate producers, and DAP imports remain priced above India's DAP maximum retail price, meaning importers will suffer losses on every cargo of DAP purchased.

To add to the expected high sulphur demand, DAP inventories are low, meaning high domestic production rates are expected in order to replenish levels over the second quarter. This means that even if demand from China remains subdued, global prices are expected to remain well into three figures next quarter as demand holds strong and supply remains tight.

There is little change on the supply side, but there are signs of the tightness potentially easing through the second quarter and going into the latter part of the year. After following a very cautious approach in the first quarter of 2021, OPEC+ agreed to increase crude quotas to full levels in line with the agreement reached in July 2020. Saudi Arabia will also ease its voluntary 1 million bbl/d cut. Meanwhile in the US, refiners continue to steadily increase utilisation rates as travel restrictions are lifted.

But the story is not the same in Europe and the Mediterranean, where countries continue to impose lockdowns and refineries struggle to maintain positive operating margins. A split is now evolving between countries successfully rolling out the vaccines and those which are making slow progress. Hopes of a global recovery in international travel this year increasingly seem optimistic, and 'normal' run rates are unlikely to return

in most regions by the end of the year, supportive of ongoing tight supply.

SULPHURIC ACID

Tightness in the global sulphuric acid market has supported prices across most major benchmarks over the past month. NW European export prices reached triple digits on the high end at the start of April, ranging \$90-100/t f.o.b. through to mid-April. This compares with a range of \$30-35/t f.o.b. at the start of 2021.

Ineos announced the proposed closure of its sulphur chemicals plant in March at Runcom and its withdrawal from the UK sulphur chemicals market. According to the company, this decision followed a detailed management review of the business. Back in October 2020 a power supply outage at the site led to the plant being taken offline. The subsequent restart showed a number of components were damaged and the plant was taken back offline. Estimates to safely repair and restart were pegged at a further 18-24 months, leading the company to effect a permanent closure of the plant. This is a blow for the UK sulphuric acid market which has already faced a period of tightness in recent months. Market participants were looking to make new trade connections and we expect to see acid imports to the UK remain healthy as a result. The closure also points to heightened prices for the local sulphuric acid market and adds pressure to an already tight NW European market.

The rollout of the Covid-19 vaccine across Europe is being closely watched, with some countries seeing a faster programme

than others. Sulphuric acid demand has been improving in the region despite second waves of the virus and localised lockdowns emerging through the first quarter. Looking ahead, Argus expects to see the tight balance to remain with little downside to pricing in the coming months. Some downward pressure is likely to lead to a price correction or stabilise the upturn as associated markets are starting to see softening. Sulphur and processed phosphates appear to have reached a peak and this may provide a ceiling to the acid market price run.

On the trade front, acid imports to Morocco dropped 16% in January month-on-month and 92% year on year. This was in part because of the tight supply situation in the global spot market. There have been difficulties sourcing supply from traditional trade routes and prices have spiked since the start of the year.

The latest Chinese trade data highlights the different sulphuric acid export routes as the tight supply situation has taken hold. Around 25,000t of Chinese supply went to countries outside regular trade patterns in February 2021. China regularly exports sulphuric acid from either the Jinchuan smelter or sulphur-based acid from Two Lions in Zhangjiagang. Regular contracts are held with Morocco, Chile, India, Australia, Indonesia, Namibia, the Philippines, Malaysia and Vietnam. South Korea, Japan, Taiwan and the Philippines import acid into the country. But in the first two months of the year, as the supply situation has grown increasingly tight, Chinese smelters have been approached

by a diverse range of markets. A shipment to Saudi Arabia and small volumes to Singapore reflected the market sentiment. Ma'aden, Saudi Arabia was also reported to be seeking two acid cargoes in the market for July and August delivery.

Export prices for spot out of China were assessed by Argus at \$85-95/t f.o.b. in mid-April. This compares with levels around \$20/t f.o.b. at the start of 2020. Meanwhile Japan/South Korea export prices have ranged from \$70-77/t f.o.b. in April.

Prices for nickel, copper and zinc have plateaued since undergoing a steep recovery over the past year, as macroeconomic momentum and the global demand recovery slow down. Prices have been broadly flat since the beginning of March – albeit with some volatility within narrow ranges – with the LME three month contracts standing at \$16,257/t for nickel, \$9,002.50/t for copper and \$2,811.50/t for zinc in mid-April. Some market participants see potential for prices to rise further in the long term, with longer positions being taken by speculative traders and corporate funds on the LME and several macroeconomic indicators such as purchasing managers' indexes picking up in March. But others are wary that the global macroeconomic recovery is reaching its limits for the time being and indicate that any significant near-term rise in base metals prices would probably depend on the 2021 demand outlook increasing. The firmer footing in base metals has been a driver supporting the sulphuric acid market at mining operations, keeping demand healthy. ■

Price Indications

Table 1: Recent sulphur prices, major markets

Cash equivalent	November	December	January	February	March
Sulphur, bulk (\$/t)					
Adnoc monthly contract	74	89	112	163	189
China c.f.r. spot	115	115	141	175	223
Liquid sulphur (\$/t)					
Tampa f.o.b. contract	69	69	96	96	96
NW Europe c.f.r.	107	119	139	160	190
Sulphuric acid (\$/t)					
US Gulf spot	60	73	83	100	135

Source: various

Fig. 1: Monthly average sulphur and sulphuric acid prices

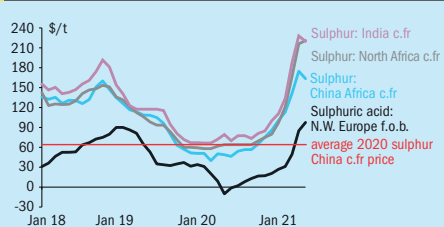

Source: Argus Media

Fig. 2: Forecast global sulphur demand changes

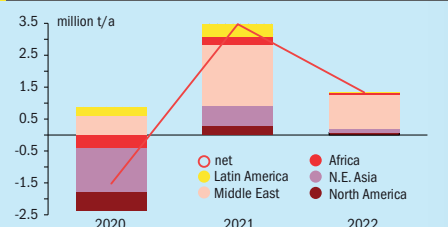

Source: Argus Sulphur Analytics

CONTENTS

What's in issue 394

COVER FEATURE 1

Sulphur market update

COVER FEATURE 2

India's acid demand

COVER FEATURE 3

SRU revamping

COVER FEATURE 4

Wet gas cleaning

SULPHUR
ISSUE 394
MAY-JUNE 2021

BCInsight

Southbank House, Black Prince Road
London SE1 7SJ, England

Tel: +44 (0)20 7793 2567

Fax: +44 (0)20 7793 2577

Web: www.bcinsight.com
www.bcinsightsearch.com

Market Outlook

Historical price trends \$/tonne

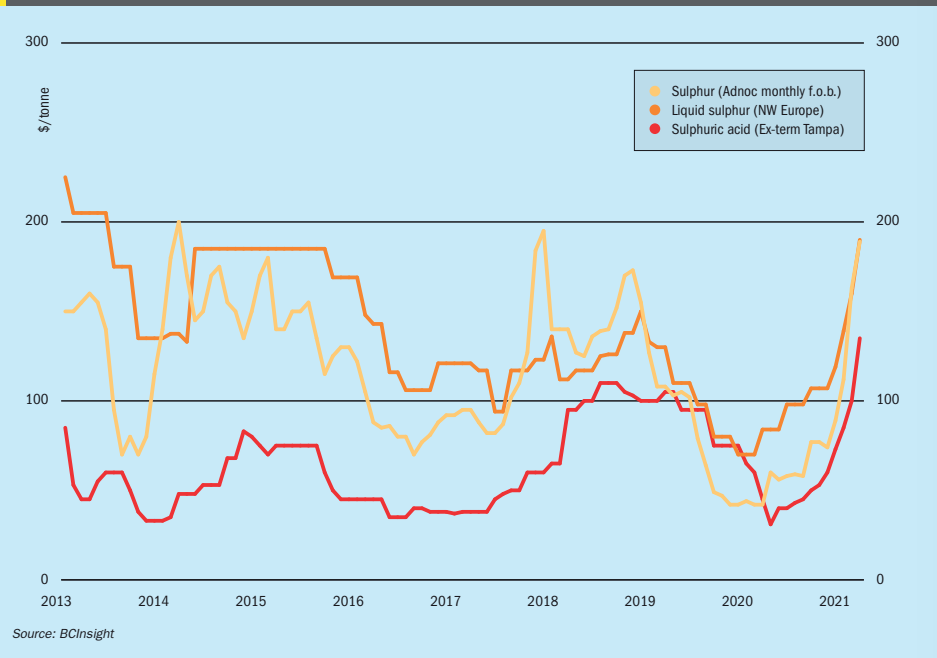

SULPHUR

- Major projects to consider in the short term outlook are Barzan in Qatar and the Clean Fuels Project in Kuwait. Combined these would add over 3 million t/a of sulphur capacity.
- China's import requirement for 2021 and in the outlook remain a major market focus following the drop in 2020 down to 8.5 million tonnes compared with 11.7 million tonnes in 2019. The rise of domestic sulphur production from oil refining remains a risk for imports, with a 10% in domestic production forecast this year. This is likely to put a ceiling on any potential recovery on import demand.
- Demand for sulphur from nickel leaching operations is expected to rise in the outlook as the demand for battery materials for the electric vehicle sector continues to rise. Projects in Indonesia are expected to ramp up demand in the coming months and this will lead to an increase in sulphur trade to the country.
- The Ambatovy nickel site in Madagascar started up at the end of March following

a year in care and maintenance, raising sulphur consumption and imports in the year ahead.

- Outlook:** Sulphur prices are expected to soften slightly as price volatility eases as second quarter contract settlements are concluded. The reintroduction of regional supply where refining operating rates improve will provide support for a price correction. This is expected to be gradual rather than a steep decline, owing to pockets of tightness, uncertainty around Covid-19 and healthy demand from the processed phosphates sector and metals and industrial markets.

SULPHURIC ACID

- The tightness in the NW European market is a major market bull with the question mark over how the UK market will manage supply in the aftermath of the Runcom plant closure.
- Positive signs from the copper sector support the outlook for acid consumption in the Americas. Projects in Arizona, US are progressing and are increasing acid requirements in the domestic mar-

ket. There is scope for further demand with a range of lithium projects in the country also advancing. While these are currently assessed as speculative there appears to be significant support to come from the US administration with increased focus on reducing emissions and policies around electric vehicles.

- Outlook:** Acid prices are at a premium to elemental sulphur prices with the decoupling of the two price ranges continuing so far in 2021. There appears to be little downside potential for acid prices in the short term with smelters holding low inventories in many regions, constrained copper concentrates supply in China and healthy demand from most sectors. Smelter based production is expected to improve this year following disruption in 2020 from the global pandemic but delayed turnarounds either into this year or the next paint a picture of tight supply in the coming months. There appears to be little reprieve expected but the downward pressure from key markets such as processed phosphates may provide a ceiling to any further price gains.



Clean Technologies



Making everyday life better, safer, cleaner

For 100 years, we have partnered sulfuric acid producers with innovative technology and expert trouble-shooting technical support. And our tradition of designing advanced solutions to solve site-specific challenges continues – so we can together deliver cleaner air productively, efficiently and reliably.

Learn more on www.cleantechnologies.dupont.com

MECS®

Sulphuric acid & environmental technologies



CONTENTS

What's in issue 394

COVER FEATURE 1

Sulphur market update

COVER FEATURE 2

India's acid demand

COVER FEATURE 3

SRU revamping

COVER FEATURE 4

Wet gas cleaning

SULPHUR
ISSUE 394
MAY-JUNE 2021

BCInsight

Southbank House, Black Prince Road
London SE1 7SJ, England
Tel: +44 (0)20 7793 2567
Fax: +44 (0)20 7793 2577
Web: www.bcinsight.com
www.bcinsightsearch.com

NIGERIA

Tecnimont to refurbish Port Harcourt refinery

Tecnimont has been awarded a \$1.5 billion contract by Nigeria's Federal Executive Council to carry out rehabilitation works at the Port Harcourt refinery in Rivers State, run by the state-owned Nigerian National Petroleum Company (NNPC). The contract covers engineering, procurement and construction (EPC) activities for a full rehabilitation of the Port Harcourt refinery complex, aimed at restoring the complex to a minimum of 90% of its 210,000 bbl/d nameplate capacity. Tecnimont says that the project will be delivered in phases from 24 and 32 months

and the final stage will be completed in 44 months from the award date.

Pierroberto Folgiero, Maire Tecnimont Group CEO, commented: "With this great result we confirm the soundness of our business strategy on geography diversification, as one of its key elements is to grow and assist our clients in their revamping initiatives, leveraging on our technological know-how to ensure more efficient and environmentally better performing processes and products."

SAUDI ARABIA

Aramco reports 44% fall in profits

Saudi Arabia's state-owned oil giant Aramco reported in March that its profits fell almost by half in 2020 to \$49 billion, a drop of 44%. Much of the fall was caused by low oil prices due to the pandemic. Aramco says that in spite of the fall of net income, it will maintain its promise of paying quarterly dividends of \$18.75 billion; \$75 billion a year, due to commitments the company made to shareholders in the run-up to its initial public offering. However, as the Saudi government still owns 98% of the company, the actual net payout to non-government shareholders will actually be only \$1.5 billion/year.

Saudi Aramco's profit was \$88.2 billion in 2019 and \$111.1 billion in 2018. It remains one of the world's most valuable companies.

"In one of the most challenging years in recent history, Aramco demonstrated its unique value proposition through its considerable financial and operational agility," President and CEO Amin H. Nasser said in a statement. "As a result, our financial position remained robust."

The company produced the equivalent of 9.2 million bbl/d per day of crude oil in 2020. Capital expenditure was down in 2020 to \$27 billion compared to \$32.8 billion the year before. Aramco expects to spend \$35 billion this year, some \$5-10 billion lower than previous estimates.

UNITED ARAB EMIRATES

Nuclear plant begins commercial operations

The Unit 1 reactor at the new Barakah nuclear power plant in Abu Dhabi has begun full commercial operations, Crown Prince Mohammed bin Zayed al-Nahyan

has announced. The reactor was completed last year and began producing electricity in August, after which a comprehensive series of tests and safety checks has been made. Unit 1 will generate 1,400MW of electricity, and will be followed by three more of a similar size. Unit 2 has completed fuel loading and is due to start up later this year. With a new 3.6 GW coal-fired power station coming on-stream in Dubai later this year, and 6 GW of new solar projects under construction by 2025, the UAE is aiming to diversify up to 50% of its power requirements away from natural gas in a few years, as part of plans to achieve net zero carbon emissions by 2050 in the energy-hungry desert kingdom, where the heat and humidity produces year-round demand for energy to run air conditioning.

The impact is likely to be felt on UAE gas demand, running at 76 billion cubic metres per year in 2019, with 20.6 of that coming from imported gas from Qatar and as LNG, balancing 7.7 bcm of LNG exports from Abu Dhabi. The UAE uses natural gas for 97% of its electricity needs, and this has driven its major expansion in sour gas drilling and processing. However, if gas demand for electricity is halved by 2025, not only will this eliminate the need for imports, it also puts the need for some new sour gas expansions in doubt.

UNITED STATES

US gasoline demand still down on 2019 levels

Year-on-year gasoline sales in the United States have moved into positive territory for the first time as the pandemic passes its first anniversary of major demand declines resulting from covid-induced stay at home orders. However, demand still trails pre-pandemic levels by a considerable margin, according to the latest data from IHS Markit. Sales in March 2021 were 10% higher than

the same period for 2020, but 16% below pre-pandemic levels. March 2020 saw volumes trail 2019 levels by 23%, as US gasoline sales plummeted to levels not seen since the Nixon Administration.

GERMANY

Partnership to develop electrically heated steam crackers

BASF, SABIC and Linde have signed a joint agreement to develop and demonstrate solutions for electrically heated steam cracker furnaces. The partners have jointly worked on concepts to use renewable electricity instead of the fossil fuel natural gas typically used for the heating process, to contribute to the reduction of CO₂ emissions within the chemical industry. The project aims to reduce CO₂ emissions by powering the process with electricity from renewable sources, potentially reducing emissions by as much as 90%. The parties are evaluating construction of a multi-megawatt demonstration plant at BASF's Ludwigshafen site, targeted for start-up as early as 2023, subject to a positive funding decision.

"This technology leap will be a milestone on the path to a low-emission chemical industry. We have not only developed the world's first electrical heating concepts for steam crackers, but also want to demonstrate the reliability of key components for use in this type of high-temperature reactors. To be able to drive a timely scale-up and industrial implementation of this technology, investment support and competitive renewable energy prices will be important prerequisites," said Dr Martin Bruderer, Chairman of BASF. The project is part of BASF's Carbon Management R&D program with which it aims to significantly further reduce its CO₂ emissions beyond 2030.

Yousef Al-Benyany, Vice-Chairman and CEO of SABIC said: "Our industry thrives on

innovation and collaboration which enable us to come up with and deliver important contributions to urgent global challenges like resource efficiency and CO₂ reduction. This agreement brings together the deep technical knowledge and implementation focus that can help transition energy-intensive processes within our industry to be low carbon emitting processes. This flagship sustainability initiative forms part of SABIC's long-term vision and climate change strategy to transform our business through the concept of circular carbon economy."

CHINA

New alkylation units pass performance tests

DuPont Clean Technologies says it has achieved successful performance tests for the new STRATCO[®] sulphuric acid catalysed alkylation units at the Zhenhai Refining and Chemical Company (ZRCC) refinery in Ningbo, Zhejiang, and the Yangzi (YPC) refinery in Nianjing, Jiangsu. The ZRCC and YPC alkylation units both process MTBE raffinate feeds and are designed to produce 7,700 bbl/d and 7,500 bbl/d (300,000 t/a) of alkylate, respectively, and will enable Sinopec to generate low-sulphur, high-octane, low-Rvp alkylate with zero olefins that meets the criteria of the China VI standard.

"This endeavour of designing and building seven alkylation units over the last several years has created strong relationships with each of the refineries. We are grateful for this opportunity to provide Sinopec with our reliable technology that enables them to produce high quality alkylate, improving the quality of the refinery gasoline pool," said Kevin Bockwinkel, global business manager, STRATCO[®] Alkylation Technology.

CANADA

Criticism over sour gas flaring at gas plant

Canadian Natural Resources Ltd (CNRL) subsidiary Sukunka Natural Resources Inc (SNRI) has faced criticism for flaring sour gas from the plant near Chetwynd, British Columbia. The plant was shut down after a strike by union Unifor for better pay and conditions at the plant began on March 9th. As a result, the company says it was obliged and permitted to flare remaining sour gas in the pipes. However, local residents complained about smells resulting from the flaring, and Unifor says that the flaring was due to "poor planning" by plant managers at the site. The

union and company remain at loggerheads over a proposed move from a 'safe idle' state to temporary decommissioning, which SNRI insists would need to be performed as a safety measure in June if the dispute continues, and which would involve removing chemicals from the site. Unifor has dismissed this as an attempt to put pressure on its members.

INDIA

BHEL wins order for sulphur recovery unit from IOCL

Bharat Heavy Electricals Ltd has been awarded an order for a new 525 t/d sulphur recovery unit (SRU) from the Indian Oil Company Ltd (IOCL) for IOCL's Paradip refinery in Odisha state. BHEL says that it won the \$53 million contract "against stiff international competitive bidding". BHEL's scope in the contract includes project management, residual process design, detailed engineering, procurement, manufacturing, supply, testing, erection, construction, commissioning and performance guarantee tests. The project is scheduled for completion in 25 months. BHEL says that this is part of the company's diversification strategy into non-coal based business areas. The company offers solutions for transportation, transmission, renewables, energy storage systems and e-mobility, water management, defence & aerospace, captive power generation and mechanical and electrical industrial products.

UNITED KINGDOM

Petrofac reaches agreement for credit facility extension

Petrofac has extended \$700 million of its banking facilities, which it says came "with the unanimous support of lenders." The extensions include a \$610 million extension of its existing revolving credit facility to 2 June 2022, with the option extend for a further six months; and a \$90 million extension of its bilateral term facility with the Abu Dhabi Commercial Bank to 1 April 2022. Previously, both facilities were due to be repaid or prepaid by 2 June 2021. Petrofac expects to report a net debt of \$116 million as of 31 December 2020.

The company has faced financial difficulties since it was banned from new contracts in Abu Dhabi due to an ongoing corruption investigation; approximately 10% of Petrofac's contract revenue came from the UAE in 2019 and the nation was its third largest market at that time, after Oman

(25%) and Kuwait (15%). A former Petrofac executive pleaded guilty to offering and making or planning to make a total of \$30 million in payment to influence the award of an engineering, procurement, and construction (EPC) contract in 2013 for the Upper Zakum UZ750 Field Development Project, in addition to a variation to that contract in 2014, and a FEED contract in 2014 for the Bab Integrated Facilities Project.

The former executive had already pleaded guilty to 11 bribery charges brought forth by Britain's Serious Fraud Office (SFO) relating to projects in Iraq and Saudi Arabia in February 2019. Those charges concerned contracts in Iraq worth more than \$730 million and contracts in Saudi Arabia worth more than \$3.5 billion.

IRAQ

Axens to supply technologies for refinery upgrading project

Axens will license technology to upgrade the Shuaiba refinery near Basra. The refinery's gasoline and diesel fuel production capacity will be increased in order to reduce the country's gap in supply and demand for petroleum products. The upgrade project involves installation of new refining units adjacent to the existing refinery facility to increase processing capacity at the site from 210,000 bbl/d to 280,000 bbl/d. Axens will deliver technologies required for the new units including a diesel hydrotreatment unit; a vacuum gas oil (VGO) hydrotreating unit; a VGO fluid catalytic cracker (FCC) unit; and an oligomerisation unit. Axens will also be responsible for providing proprietary equipment, trainings and technical services.

Axens process licensing conversion & clean fuels business line director Jacques Rault said: "The Basrah refinery is expanding its operations by increasing its gasoline and diesel production while improving the fuels quality. This will help to solve one of the main challenges to lower national petroleum products imports revitalising the Iraqi refining sector damaged by war and deterioration."

JGC is serving as the overall EPC contractor for the \$3.8 billion upgrading project at the state-run South Refineries Co site, including a 55,000 bbl/d FCC unit, a 31,000 bbl/d naphtha hydrotreater unit and a new 17,000 b/d Continuous Catalytic Reforming unit, which will be the first of its kind in Iraq and will allow the country to produce 100 RON gasoline. The project is scheduled to be completed in 2025. ■

CONTENTS

What's in issue 394

COVER FEATURE 1

Sulphur market update

COVER FEATURE 2

India's acid demand

COVER FEATURE 3

SRU revamping

COVER FEATURE 4

Wet gas cleaning

SULPHUR
ISSUE 394
MAY-JUNE 2021

BCInsight

Southbank House, Black Prince Road
London SE1 7SJ, England

Tel: +44 (0)20 7793 2567

Fax: +44 (0)20 7793 2577

Web: www.bcinsight.com
www.bcinsightsearch.com

UNITED KINGDOM

Inovyn to close sulphuric acid plant at Runcorn

Ineos subsidiary Inovyn has announced the permanent closure of its 'sulphur chemicals' (mainly sulphuric acid) plant at its Runcorn site, and its withdrawal from the UK sulphur chemicals market. The company said in a statement that the decision follows a management review of the business in the light of recent events. Specifically, in October 2020, an unexpected interruption to the third-party power supply to the Runcorn site resulted in the plant being taken offline, and during restart, it was identified that a number of critical plant components had suffered significant damage. As a result, to ensure the safety and integrity of the plant it was taken back offline. Since then, in spite of significant

effort and investment to rectify these issues, Inovyn says that it has become clear that it will not be possible to safely restart the plant for at least a further 18-24 months, and the company has decided to close the plant permanently.

The move has sent shockwaves through the UK sulphuric acid market. The plant produced 300,000 t/a of sulphuric acid at capacity, and was the main domestic source of acid for downstream industries in the UK, including water treatment, chemicals and fertilizer production. The UK also imports around 330,000 t/a of acid, mainly from Germany, Finland and Norway, but its ability to almost double this in a short period is very much open to question. ■

BOTSWANA

Metso Outotec to supply technology to copper-silver project

Metso Outotec has signed a euro 17 million contract to deliver all of the main process technologies for Sandfire Resources' flagship Motheo copper-silver concentrator in Botswana. The 3.2 million t/a greenfield plant will be built in the Kalahari copper belt in Botswana, with the potential to expand to 5.2 million t/a in the future. Metso Outotec will deliver all key minerals processing equipment including gyratory and pebble crushers, apron feeders, semi-autogenous (SAG) mill and flotation cells, fine grinding mill, high rate thickeners, and a pressure filter. Additionally, spare parts and supervisory services will be supplied to support commissioning and plant ramp up. Delivery will take place during 2021 and 2022, and the plant is expected to start production in late 2022 or early 2023.

"We are pleased to continue our strategic partnership with Sandfire Resources. We have worked with Sandfire in the past and are very grateful to be selected again for their flagship Motheo project. Our proven proprietary and sustainable technologies will support Sandfire with achieving their international growth and diversification strategy," said Kai Rönnerberg, Vice President, Minerals Sales, Asia Pacific at Metso Outotec.

FINLAND

Metso Outotec completes reorganisation of Metals business

Metso Outotec has completed the reorganisation of its Metals business as part of the turnaround program announced in

Q4/2020. As a result of negotiations with employees and other stakeholders, approximately 100 jobs will be reduced globally, including 15 in Finland. Most of the global reductions are through redundancies and the rest through other arrangements, such as retirements, non-renewal of fixed-term contracts, and voluntary resignations. In addition, over 50 employees who were in the scope of the Metals reorganization will continue in Metso Outotec in other parts of the company.

"The reorganisation of the Metals business aims for annual savings of €15 million", said Jari Älgars, President, Metals business area at Metso Outotec. "During the negotiations, we carefully evaluated all opportunities with the target to find the best possible options to meet the needs of our customers and employees. The now completed reorganisation empowers the Metals business lines for efficient use of resources and faster decision-making."

UNITED STATES

ITC supports duties on phosphate imports

The United States International Trade Commission (ITC) ruled in March that subsidies associated with the import of phosphate fertilizers from Morocco and Russia are injuring the United States industry, and announced that the US Department of Commerce "will issue countervailing duty orders on imports of phosphate fertilizers from Morocco and Russia."

Last August, the ITC announced that it would continue its investigation and said that it had "determined that there is a reasonable indication" that the United States' industry was being harmed by the tariffs. In its accompanying publication, the

ITC noted that The Mosaic Company filed petitions on June 26, 2020 alleging that it had been injured because of the subsidies given to imports of phosphate fertilizers.

Mosaic said in a press release that this decision will help make the American fertilizer industry more competitive. "Mosaic employees are proud to support American farmers by producing high quality, reliable fertilizer," said Mosaic President and CEO Joc O'Rourke. "Today's decision upholds our belief that fair trade is a cornerstone of a healthy U.S. economy, and that American farmers will benefit from having a more competitive American fertilizer industry."

Mosaic reported that the Department of Commerce will levy duties of 20% for OCP, a Moroccan producer. Russian producers will have duties of 17% except for PhosAgro which will be 9% and EuroChem at 47%. These increased duties will remain for at least five years.

Leak from phosphate waste water pond

Florida Governor Ron DeSantis declared a state of emergency in early April after a waste water leak from the Piney Point phosphate mine flooded roads and threatened to pollute local watercourses. The long-abandoned mine operated from 1966 to 2001, but phosphogypsum waste from phosphate processing still sits in large piles at the site; around 5 tonnes of phosphogypsum for every tonne of phosphoric acid produced, up to 1 billion tonnes of phosphogypsum across the state as a whole. The wrinkle in Florida is that the phosphogypsum is mildly radioactive due to the presence of uranium in the phosphate ore.

Around 215 million gallons of acidic waste water were pumped into Tampa

Bay, and while around 223 million gallons remain in the pond at Piney Point, repair crews were able to stop the leak. Two additional stacks with wastewater containment ponds remain at Piney Point, and fears have been expressed that an unaddressed breach could lead to a sudden rush of water from these ponds.

Meanwhile, Mineral Development LLC has broken ground on a \$70 million secondary phosphate recovery facility in Polk County, Florida. The plant is designed to produce 1.2 million t/a of high-quality phosphate rock in a range of qualities from 29% to 34% P₂O₅, extracting phosphate from mine tailings and reusing water from existing ponds. The process helps restore the land to its original state with native vegetation and natural surface water flow while providing high-grade phosphate essential to feed the world's growing population, according to the company. MDL's facility is the first independent phosphate beneficiation plant built in the US in over 30 years.

GERMANY

'Next generation' electrostatic precipitators

Dürr Megtec has launched what it describes the "next generation" of wet electrostatic precipitators (WESP) to efficiently clean industrial gases of fine particulate matter, acid mists and aerosols to meet global environmental regulations and protect downstream equipment. A strong focus was placed on the system's high-intensity, offline automatic cleaning features, which reduce maintenance efforts, eliminate carryover of entrained matter during washing and provide better operational performance during cleaning. System components are also now easily accessible for maintenance inspections, the company says. In order to enhance the performance of its WESP, Dürr Megtec aimed at achieving a more efficient contaminant capture. This was achieved through increased operating voltage that requires less collecting surface area. Additionally, the gas distribution system was completely reimagined to optimise flow through the system, and various tube shapes and electrodes were tested to improve overall performance. Standardised modules are used in the new design, reducing engineering time and streamlining fabrication. The systems are assembled from different standard modules and adapted to customer-specific requirements. Modules with tube bundles

are pre-assembled in Dürr's production facility for shipment to the customer. All electrodes are pre-loaded and pre-aligned, for reduced installation times. The company says that its WESPs can remove up to 98% of particulate in a single stage, depending on the characteristics of the gas stream. Increased removal efficiency is possible with alternative configurations.

RUSSIA

Nornickel to close Monchegorsk

Russian metal producer Norilsk Nickel has announced that it will close its nickel smelter in the city of Monchegorsk in Russia's Kola Peninsula near the borders with Norway and Finland as part of the company's programme to move towards greener production. Closing the smelter will reduce sulphur dioxide emissions in Monchegorsk to less than 30,000 t/a in 2021, and taken together with the December 2020 shutdown of the smelter at Nikel, it will reduce the company's emissions in the Kola Peninsula by 85% in 2021 compared to the figure for 2015. Next year, emissions will be limited to 22,000 t/a of sulphur dioxide, of which 8-9,000 (depending on the season) will be from the power plant, which also heats homes in Monchegorsk. Nornickel plans to upgrade the plant and build a modern copper refining facility in the town with double the annual capacity – up to 150,000 t/a – and higher environmental standards.

"The old, ineffective plant will be closed and a new one meeting the highest environmental standards will be built in its place," said Norilsk Nickel's Vice President for Strategy Sergey Dubovitsky. "These standards mean that almost all gases will be captured. The project also provides for utilisation of these gases and the production of sulphuric acid."



Nornickel's Monchegorsk site.

Nornickel plans to build a new copper line on the Kola Peninsula by 2025, and before that copper output will be moved to its polar division, where facilities have already been upgraded. It is also aiming to increase production at its nickel refinery in Finland due to surging demand for battery raw materials in the European market. Mainly powered by renewable energy, the Harjavalta plant uses sulphuric acid leaching for nickel semi-products to enable hydrometallurgical production of 65,000 t/a of high purity nickel using ore from Russia. Nornickel plans to increase production at the NN Harjavalta plant to 75,000 t/a in 2023 in the first phase. The production will be further increased to exceed 100,000 t/a by early 2026 in the second phase.

TURKEY

Škoda to provide steam turbine for acid plant

Czech manufacturer Doosan Škoda will supply a 15 MW steam turbine, generator and associated equipment for the Etimaden EMET sulphuric acid plant being built in Kütahya Province. The company's engineers will also supervise assembly of the unit at the construction site. The plant will be in continuous operation for 330 days a year and the steam turbine will generate electricity from residual heat for both the plant's own operation and the surrounding area.

"The EMET sulphuric acid production facility will make a significant contribution to Turkey's boron treatment and boron products process which have a wide range of usage areas including but not limited to agriculture, cleaning, metallurgy, health and textile," said Yaman Coşkun, representative of Turkish EPC contractor Ekon. "Alongside the production of sulphuric acid, the plant will also supply electricity to the EMET Boron."



The Murrin Murrin HPAL facility.

Doosan Škoda Power is on a tighter deadline than usual, having 12 months from the date of signing the contract to supply the turbine unit to the construction site. Foundation bolts and other built-in components are scheduled to be delivered by February 2022, said project manager Lucie Franková.

ZAMBIA

New acid plant for copper processing

Kumbele Mining Ltd, owned by a consortium of Chinese investors, has set aside \$150 million to develop a small scale copper processing plant in Chingola. According to the environmental impact assessment (EIA) report submitted to the Zambia Environmental Management Agency, the copper reclamation project is expected to have a lifespan of 30 years. The plan is to process tailings from the Nchanga open pit mine, the second largest in the world, using a hydrometallurgical process. The company statement says that: "Kumbele Mining Limited intends to develop and operate a copper mine as well as construct and operate a copper processing plant, a sulphuric acid plant and tailing storage facility within the exploration area in Chingola."

CHINA

Smelters taking enforced downtime

Tight supply in the copper market is squeezing copper smelters, especially Chinese ones, leading many to take maintenance downtime, according to Reuters. A lack of concentrates supply has caused smelter treatment charges to tumble and reducing the smelter sector's profitability. China's top smelters failed to agree a minimum floor price for second-quarter purchases, and Goldman Sachs estimates that 700,000 t/a of annual capacity will be affected in April, two million tonnes in May and a further 900,000 t/a in June.

plants with a combined capacity of 1,000 t/d of oxygen, according to the company.

INDONESIA

Finance deal for HPAL plant

Singapore bank DBS Group says that it has co-led a group of lenders in a \$625 million financing deal for a nickel and cobalt project in Indonesia. The project by PT Halmahera Persada Lygend is expected to be the first plant in Indonesia to use high-pressure acid leach (HPAL) technology to produce nickel and cobalt chemicals used in making batteries for electric vehicles. DBS, Southeast Asia's biggest bank, said it has joined BNP Paribas BNP.PA to lead a consortium with seven other banks to launch a \$600 million term loan facility and a \$25 million working capital facility in a seven-year deal for the HPAL project. The other lenders were Indonesia's Bank Mandiri BMRI.JK, Bank Negara Indonesia BBNI.JK, OCBC NISP NISP.JK, Bank Central Asia BBKA.JK, Malaysia's Maybank MBBM.KL, Singapore's Oversea-Chinese Banking Corp Ltd OCBC.SI and United Overseas Bank Ltd UOBH.SI.

Based in Indonesia's Obi island, the HPAL project is a joint-venture between China's Lygend Mining and Indonesia's Harita Group.

"PT HPAL is committed to controlling the use of energy sources in every step of our production processes in pursuit of good environmental governance through implementation of low emission technology," a PT HPAL spokesman said.

This could result in a loss of processed metal of up to 250,000 tonnes, and a corresponding dip in acid supply. Worldwide, copper smelting activity has slipped to its lowest in at least five years in March.

DEMOCRATIC REPUBLIC OF CONGO

Glencore reports acid spill

Glencore has confirmed that a tank containing sulphuric acid ruptured in March at its Kamoto Copper Company (KCC) mine in Katanga Province. The company said that a "limited release" of acid had occurred during maintenance at KCC. "At approximately 7pm on 16 March, KCC experienced a limited release of acid from Tank Farm 1 during maintenance work. There was no explosion," Glencore said in a statement. "Follow-up with the community was conducted to advise of the event and our community officers have not registered any complaints nor concerns from their engagement with the surrounding communities."

INDIA

New smelter for India

India's Adani Enterprises says that it plans to build its first copper cathode facility via a new subsidiary three years after the country's biggest copper smelter – Vedanta's Tuticorin – was ordered to close.

In its submission to the Indian environmental regulator, Adani subsidiary Kutch Copper Ltd (KCL) said that the new copper complex will consist of 900,000 t/a of primary copper smelting capacity and 100,000 t/a of copper scrap smelting capacity.

The Tuticorin smelter remains idle after its closure by the Tamil Nadu Pollution Control Board (TNPCB). The company has recently suggested that the smelter's oxygen plants could be utilised to meet India's ongoing demand for medical oxygen as the Covid pandemic enters a new phase in the country. The Sterilite Copper plant has two oxygen

AUSTRALIA

Acid plant failure cuts production at Murrin Murrin

Glencore says that it has temporarily reduced production at the Murrin Murrin nickel-cobalt operation in Western Australia following a malfunction at an acid plant at the site. The plant, 880km east of Perth in the north-eastern Goldfields region, processes and refines nickel and cobalt to produce LME grade metal briquettes on site. Glencore said that a component failure occurred at one of the two acid plant fans at the site. Details were not disclosed regarding how long repair work may take.

Glencore's Murrin Murrin site comprises a high-pressure acid leaching (HPAL) plant and a refinery, a 90MW power station, and a 4,400 t/d acid plant. In 2020, the mine accounted for about 31% of the company's nickel production.

Safe Heat Exchanger
SAFEHX

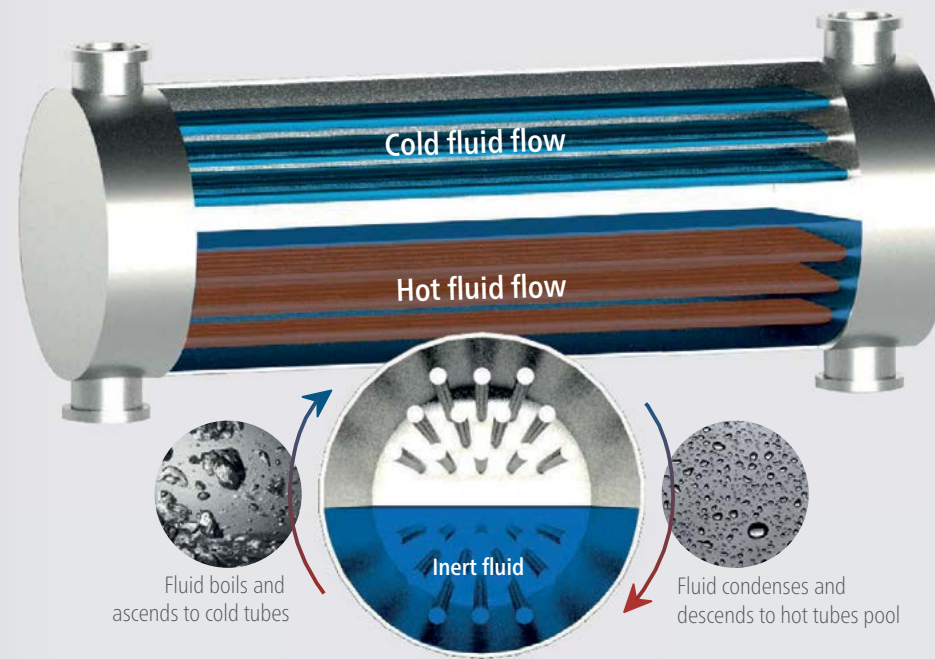

Learn more: clarksolutions.com

Phase change heat exchanger

SAFEHX is a new, innovative concept in heat exchange. A buffered heat exchanger that besides high heat transfer rates provides stable and precisely controlled tubewall and bulk fluid temperatures as well as intrinsic safety against fluid cross-contamination or loss due to corrosion or process pitfalls.

Clark Solutions

clarksolutions.com | Follow us:



CONTENTS

What's in issue 394

COVER FEATURE 1

Sulphur market update

COVER FEATURE 2

India's acid demand

COVER FEATURE 3

SRU revamping

COVER FEATURE 4

Wet gas cleaning

SULPHUR
ISSUE 394
MAY-JUNE 2021

BCInsight

Southbank House, Black Prince Road
London SE1 7SJ, England
Tel: +44 (0)20 7793 2567
Fax: +44 (0)20 7793 2577
Web: www.bcinsight.com
www.bcinsightsearch.com

People

Calgary-based Pieridae Energy Ltd says that it has hired a new Chief Operating Officer as from April 5th. **Darcy Reding** is a professional engineer with 30 years of experience in small and medium-sized private and public upstream oil and gas companies, 20 years of that in leadership roles. Reding spent the last decade at NAL Resources as VP of Operations and VP Operations & Geoscience. Prior to NAL, Reding held technical and leadership roles with Norcen Energy, Northrock Resources, Samson Exploration and Enterra Energy Trust.

"We are extremely pleased that Darcy has agreed to join our organisation," said Pieridae CEO Alfred Sorensen. "It is critical we have someone with senior-level experience running complex sour gas assets. Darcy brings us that skill set and is well positioned to take full advantage of the opportunities Pieridae's assets offer. We also needed someone with a proven record of building a resource base and economically bringing on new reserves that will be critical to filling our gas plants and delivering long-term success. Darcy has previously managed a billion-dollar multi-year program to successfully grow production volumes."

Chuck Magro is to step down as CEO of Nutrien Ltd, the world's largest fertilizer maker, in order to pursue new opportunities. The company has named **Mayo Schmidt** its new chief executive officer. Magro will be "available to" the company until May 16th to facilitate a smooth transition, according to a Nutrien statement.

"I look forward to leading the continued execution of Nutrien's strategy and driving

industry-leading performance across all our lines of business," Schmidt said in a statement. "Over the coming weeks, I will be connecting with our employees, valued customers and shareholders to continue building our positive momentum and our focus on advancing sustainable solutions to feed a growing planet."

Schmidt was named chair of Nutrien's board of directors in May 2019 and will remain on the board. He previously served as president and CEO of Viterra and Hydro One Ltd. **Russ Girling**, the former president and CEO of TC Energy, was named the new chair of Nutrien's board of directors.

"Mayo is a remarkable leader who is committed to our values of safety and integrity, our purpose and our strategy focused on sustainably feeding the world," Girling said. "Under his leadership, along with our deep and experienced executive leadership team and our 27,000 dedicated employees, the board is confident the company is well positioned to continue to grow and create enduring shareholder value."

Nutrien was created in 2018 after the merger of Agrium and PotashCorp. Magro, who was the CEO of Agrium at the time of the merger, was named Nutrien's CEO.

"I am very proud of the strong foundation we have built at Nutrien over the last several years," Magro said, who also resigned from Nutrien's board of directors. "I am grateful for the dedication of our employees, and the important partnerships we have forged with our customers and stakeholders. I have enjoyed every moment of my time at Nutrien, and I wish the com-

pany and its people continued success."

The company also announced it is reducing the size of its board of directors from 12 to 11 with Magro's resignation from the board.

Fertilizer Canada has appointed **Karen Proud** as President and Chief Executive Officer. Proud assumes leadership from Garth Whyte, who has served as President since 2015. Whyte announced his retirement in the summer of 2020. Prior to joining Fertilizer Canada, Proud was the COO of Food Health and Consumer Products of Canada.

"Fertilizer Canada has a well-earned reputation in both programming and advocacy initiatives," said Proud. "Having worked for a number of manufacturing and retail sectors I am excited to take on this new role aimed at advancing the safe, secure, and sustainable production and use of fertilizer in Canada and around the world."

"Karen's experience in association management and regulatory negotiation will ensure a continued focus on our industry's priorities, including achieving federal recognition for 4R Nutrient Stewardship as the national standard for nutrient management and the industry's codes of practice as the standard in product safety, as outlined in our Strategic Plan 2025," said Brian Markand, Chair, Board of Directors, Fertilizer Canada. "As a proven leader and relationship-builder, in combination with her extensive background and knowledge of government decision making, Karen will further develop and build upon Fertilizer Canada's foundation of achieving fair, competitive and science-based policies." ■

Desmet Ballestra offers design and supply of plants and relevant field services for the production of sulphuric acid, oleum, SO₂ and SO₃.

- Permanent licensee of DuPont MECS® for major sulphuric acid/oleum units
- Proprietary technologies and know-how for small sulphuric acid/oleum and SO₂/SO₃ units
- Updated DuPont MECS® HRS™ system for enhanced heat recovery
- Tail gas cleaning systems and emissions control
- Wide range of production capacities and customized solutions according to specific customers' requirements
- Spare parts and technical assistance support worldwide

Over 25 units have been successfully delivered and installed worldwide.

desmet ballestra



Science
behind
Technology

Calendar 2021

MAY

3-7

Brimstone SRU Maintenance and Reliability – **Online training course**
Contact: Mike Anderson, Brimstone STS
Phone: +1 909 597 3249
Email: mike.anderson@brimstone-sts.com

10-14

Amine Treating Training – **Online training course**
Contact: Paula Zaharko, Sulphur Experts
Tel: +1 281 336 0848 Ext 101
Email: Paula.Zaharko@SulphurExperts.com

17-21

Sulphur Recovery Training – **Online training course**

! The following events may be subject to postponement or cancellation due to the global coronavirus pandemic. Please check the status of individual events with organisers.

Contact: Paula Zaharko, Sulphur Experts
Tel: +1 281 336 0848 Ext 101
Email: Paula.Zaharko@SulphurExperts.com

19

The Sulphur Institute Sulphur World Symposium 2021 – **Virtual event**
Contact: Sarah Amirie, The Sulphur Institute
Tel: +1 202 331 9660
Email: samirie@sulphurinstitute.org

JUNE

2

European Sulphuric Acid Association General Assembly – **Virtual event**
Contact: Francesca Ortolan, Cefic
Tel: +32 2 436 95 09
Email: for@cefic.be

11-12

45th Annual International Phosphate Fertilizer and Sulphuric Acid Technology Conference, CLEARWATER, Florida, USA
Contact: Miguel Bravo, AIChE Central Florida Section
Email: vicechair@aiche-cf.org
Web: aiche-cf.org/Clearwater_Conference

SEPTEMBER

12-15

2021 Australasia Sulphuric Acid Workshop, BRISBANE, Australia
Contact: Kathy Hayward, Sulphuric Acid Today
Email: kathy@h2so4today.com
Web: www.acidworkshop.com

CONTENTS

What's in issue 394

COVER FEATURE 1

Sulphur market update

COVER FEATURE 2

India's acid demand

COVER FEATURE 3

SRU revamping

COVER FEATURE 4

Wet gas cleaning

SULPHUR
ISSUE 394
MAY-JUNE 2021

BCInsight

Southbank House, Black Prince Road
London SE1 7SJ, England
Tel: +44 (0)20 7793 2567
Fax: +44 (0)20 7793 2577
Web: www.bcinsight.com
www.bcinsightsearch.com



The Savage Midwest Sulphur Forming Facility, Chicago.

PHOTO: MATRIX POM ENGINEERING

Sulphur markets remain unpredictable

While the covid pandemic has kept refinery run rates down in 2020, new refinery sulphur capacity will nevertheless form the bulk of new additions to sulphur production over the next few years. But delays to projects on both the supply and demand sides could tip a fairly balanced market in either direction.

The sulphur market has faced a rollercoaster over the past two years, mostly due to the disruptions caused by the coronavirus outbreak. Middle East f.o.b. prices dropped from around \$170/t in January 2019 to below \$50/t in January 2020, before beginning a climb in the second half of last year that has now seen them rise back towards \$200/t. World production of elemental sulphur dropped by nearly 1% to around 65 million tonnes in 2020, with most of the fall coming from refinery slowdowns in Europe and North America, balanced by new refinery start-ups in the Middle East and Asia.

Elemental sulphur production continues to come almost exclusively from recovered sulphur from refineries and sour gas plants, with mined sulphur less than 1% of production, and the impact of covid upon the refining industry has been consider-

able. Demand, particularly from phosphate fertilizer production, has largely held up as governments prioritise agriculture, but industrial demand took a knock and has only slowly recovered.

Supply - refineries

In general the trend for sulphur supply from refineries has been a steady increase for several decades, as regulations on the permitted sulphur content of fuels tighten to reduce emissions of sulphur dioxide, especially from vehicles, to reduce the impact on public health. While most countries have now moved to a 50ppm or lower sulphur content in fuels (15ppm or less in most of the developed world) standard, and so the extra amount of sulphur being produced to reach higher standards is relatively modest, refinery sulphur production saw another

boost due to the International Maritime Organisation's move from a global 3.5% cap on sulphur in bunker fuels to 0.5%, and 0.1% in emissions control areas.

At the same time, vehicle use continues to rise, especially in Asia. Global car sales rose from just over 60 million units in 2009 to over 90 million per year in 2018, although demand fell by 3 million units/year in 2019, especially in China, due to environmental concerns about diesel cars and an anticipated regulatory response, and the growth of ride-hailing and car-sharing schemes. The covid pandemic saw new vehicle sales slump around the world to just 73 million units.

The longer term impact of the pandemic remains hard to judge. The coronavirus has forced rapid changes in our behaviour, from increased home working to enforcing drastic cuts in business and leisure air travel. Initially these were thought to be likely to be temporary dislocations for a few months, with a return to 'normality' in 2021. However, it is becoming increasingly clear that in spite of the largest global vaccination programme in history currently being under way, and showing clear dividends in countries like Chile, Israel and the United Kingdom at time of writing, the global situation remains highly precarious, with countries such as India and Brazil suffering terrible secondary peaks. The emergence of new more transmissible variants of the virus, and the possibility that some of these may out-evolve the current roll-out of vaccines, mean that we are likely to face global restrictions on our movement for at least another year, and possibly indefinitely. At the same time, more and more governments are focusing on the potential for a sustainable recovery as a way to accelerate momentum towards a low-carbon future.

In this scenario, the prospects for oil demand are for lower consumption to continue. Increases in global oil consumption had already been slowing noticeably before covid, and in 2019 consumption rose by only 0.8%. About 40% of demand is accounted for by road vehicle fuel consumption, and this already faced lower demand due to the increasing fuel efficiency of vehicles, and a steady move towards electric power trains which has been accelerated by the pandemic. Many countries now plan to ban new fossil-fuel based cars from sale by 2030. Ageing global populations (who drive less), the saturation of vehicle ownership in formerly industrialising economies, and the

increasing use of ride sharing apps and other shared mobility services are all converging to counter the increased number of vehicles on the roads. The International Energy Agency's most recent (March 2021) forecast puts global oil demand at 104 million bbl/d by 2026, up 3.5 million bbl/d on 2019, but 2.5 million bbl/d below previous projections, and it includes a 'sustainable development scenario' that would instead see demand fall by 3 million bbl/d to 2026 compared to 2019's peak.

Meanwhile, a wave of refinery capacity rationalisation is underway around the world. Global shutdowns of 3.6 million bbl/d have already been announced, but a total of at least 6 million bbl/d would be required to allow utilisation rates to return to above 80%.

The impact has been to accelerate longer term changes that were already clear in the market, pushing new refinery production towards Asia and the Middle East, where all new refinery capacity that comes on-stream by 2026 will be located. Asian crude oil imports are projected to surge to nearly 27 million bbl/d by 2026, requiring record levels of both Middle Eastern crude oil exports and Atlantic Basin production to fill the gap. The centre of gravity for refined products trade is also set to shift to Asia, resulting in the region's oil import dependence rising to 82% by 2026.

This will also therefore impact upon sulphur production. The new Kuwaiti refineries at Mina al Ahmadi, Mina Abdullah and Al Zour, will between them add 1.8 million t/a of new sulphur production capacity, and all are likely to be up and running this year. Saudi Arabia's Jazan refinery adds another 700,000 t/a, as does RAPID in Malaysia and new refineries in China a further 1.5 million t/a of sulphur.

Elsewhere, US refinery throughputs have dropped slightly due to lower refinery operating rates, removing about 400,000 t/a of sulphur from the market in 2020, but this is expected to rebound over the next few years. European refinery output likewise dropped by about 450,000 t/a in 2020 and is expected to rebound a little this year, but as much of the continent enters a second wave of covid infections, it may be 2022 before any significant increase is seen.

In Canada, processing of heavy oil sands crude has been impacted both by low oil prices and the saturation of export routes to the US as well as the covid crisis, and output dropped by about 300,000 bbl/d in 2020. Nevertheless, in spite of

increasing questions over the environmental cost of oil sands production, the Canadian government continues to forecast steady growth in oil sands production and processing out to 2050.

Supply - sour gas

The other main source of sulphur is from processing of sour gas. Use of natural gas has been on a rising trend for many years, rising 35% during the previous decade from 2.94 trillion cubic metres in 2009 to 3.93 tcm in 2019. Last year saw a decline in natural gas consumption as well, by about 4%, and while this is expected to rebound this year, the rate of increase in gas demand is slowing, from around 5% per year during the 2010s to around 1.5% per year for the 2020s. Gas is still in demand for power production, as it is seen as cleaner than coal in terms of carbon emissions and gas-fired power stations are cheaper and easier to set up. The rapid growth of a global LNG market has made access to natural gas cargoes available to anyone who can build a receiving terminal, and a much more liquid gas market has eased it away from being tied to oil indexed pricing. Nevertheless, as more renewable and nuclear power is installed, so the 'dash for gas' that characterised the previous three decades is slowing. Demand growth has been strong in North America as cheap shale gas displaces coal-fired power generation capacity, and also in the industrialising countries of Asia. It has also seen a surge in the Middle East, where rapidly rising populations and demand for electricity in fast-growing cities like Dubai and Abu Dhabi have pushed growth in power generation. Conversely, Europe has seen gas consumption fall because of falling domestic production and the higher cost of importing from Russia and the international LNG market.

One issue for the gas market is that supply from new conventional gas fields is becoming harder to source, and there has consequently been considerable growth in 'unconventional' gas - from shales, coalbed methane, or 'tight gas', as well as biogas and other sources. Lack of availability of sweet gas in some regions, especially the Middle East, but also including China and Central Asia, has led to an increasing focus on sour gas resources to meet demand. This in turn continues to generate large new volumes of sulphur.

The major centres of sour gas production used to be Europe and Canada, where it was pioneered, but production is in long

Fig. 1: Elemental sulphur production in 2020

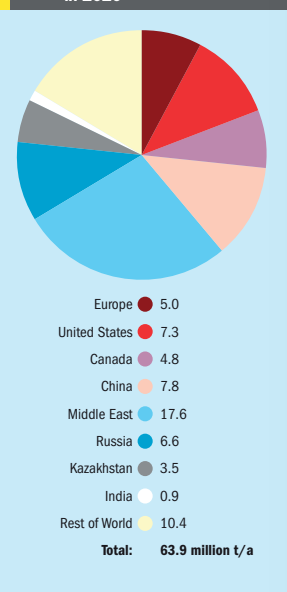

CONTENTS

What's in issue 394

COVER FEATURE 1

Sulphur market update

COVER FEATURE 2

India's acid demand

COVER FEATURE 3

SRU revamping

COVER FEATURE 4

Wet gas cleaning

SULPHUR
ISSUE 394
MAY-JUNE 2021

BCInsight

Southbank House, Black Prince Road
London SE1 7SJ, England

Tel: +44 (0)20 7793 2567

Fax: +44 (0)20 7793 2577

Web: www.bcinsight.com
www.bcinsightsearch.com



PHOTO: KPC

Sulphur storage at Mina al-Ahmedi, Kuwait.

term decline in both regions. The Lacq field in France is no longer in production and sulphur output from Grossenknetten in Germany has halved over the past decade to 450,000 t/a and is likely to steadily fall further. Likewise sulphur output from Alberta and British Columbia could fall another 300,000 t/a out to 2025.

Chinese production has plateaued at about 2.6 million t/a of sulphur from three gas plants, at Chuangdongbei, Puguang and Yuanba. However, the start up of additional capacity at Chuangdongbei is expected over the next few years, perhaps increasing output by 600,000 t/a overall. Central Asia has seen the start-up of the South Yolotan/Galkynshour sour gas plant in Turkmenistan, and the re-start of the huge Kashagan sour associated gas project, as well as additional production at Tengiz and the Kadym project in Uzbekistan. However, most new sulphur from sour gas is coming from the Middle East, where Saudi Arabia added 1.3 million t/a of sulphur production capacity via the Fadhili gas plant last year. Qatar's long-delayed Barzan LNG project will generate an additional 800,000 t/a sulphur once it is commissioned, now scheduled for this year, and Abu Dhabi is expanding the already huge Shah sour gas project to add a potential 1.7 million t/a of sulphur from around 2023. But Abu Dhabi has recently started up a large nuclear power station and Dubai is completing a coal-fired station. Coupled with major expansions in solar power production, the UAE's needs for additional sour gas may be more modest than previously expected and several large new sour gas projects further down the pipeline are now in doubt.

www.sulphurmagazine.com

Demand – sulphuric acid

Most sulphur – around 90% – is consumed as sulphuric acid. Sulphuric acid is the most widely used industrial chemical, but burning elemental sulphur is not the only source of sulphuric acid – around 8% comes from roasting of iron pyrites, mainly in China, and another 30% from capture of sulphur dioxide emissions at metallurgical smelters. The smelter acid segment is involuntary production and tends to be relatively independent of sulphur prices, but instead determined by the markets for base metals, especially copper. There is however some interchangeability between sulphuric acid and sulphur for some producers, like OCP in Morocco, who can to a limited extent turn from buying sulphur on the international market to importing sulphuric acid directly instead. This complicates the market for elemental sulphur slightly, as it must to an extent compete with pyrites and smelter acid production, especially in countries like China. As smelter acid, as a waste product, can often be relatively inexpensive, it can often be preferred where there is a source of supply locally. But the difficulties of storing and transporting large volumes of acid have conversely also meant that some consumers have installed sulphur burning capacity in order to gain greater control over feedstock supply.

Phosphates

About 60% of sulphur (in all forms) demand is provided by phosphate fertilizer production, usually to treat phosphate

rock to make phosphoric acid, which is then converted into ammonium phosphate or triple superphosphate, but some is used directly to make single superphosphate (SSP). According to Nutrien, global phosphoric acid production stood at 47.1 million t/a P_2O_5 in 2019, about 85% of which was used for fertilizer production. Phosphate fertilizer demand became the mainstay of sulphur demand because of rising global populations and more intensive agriculture in many parts of the world during the second half of the 20th century, especially in Asia and Latin America. From 1950 to 1990 phosphate demand grew fivefold. But while phosphate fertilizer remains under-applied in Africa, many global markets for phosphates are mature now, and issues caused by over-application of phosphate and its leaching into water courses has led to a focus on reducing its use in Europe and more recently China. Overall phosphoric acid demand growth has progressively slowed, and is projected to rise at only 1.1-1.4% per year over the next five years.

However, one bonus for the sulphur industry is that the fertilizer industry has proved to be resilient to covid-related shutdowns in terms of demand. Indeed, 2020 actually saw a bumper demand year for phosphates, even coming on the back of 2019, which had been a rebound from the demand dip of 2018. Brazil and the United States saw increases in phosphate fertilizer demand last year, and India also saw major stock drawdowns in response to surging demand for DAP, and imports having to make up for disruption to production caused by covid earlier in the year.

In terms of new production and hence demand for sulphur, there is another 3.4 million t/a P_2O_5 of new phosphoric acid capacity projected to start up out to 2025, including 1.2 million t/a at OCP via both new capacity and debottlenecking of existing plants, as well as new capacity in India, Kazakhstan, Indonesia, the Philippines, Tunisia, and the El Wady for Phosphate Industries and Fertilizers (WAPHCO) plant in Egypt. This will be balanced by around 500,000 t/a of further projected closures in China. Nevertheless, with demand projected to rise by 3.3 million t/a P_2O_5 over the same period, all of this capacity will be needed as well as likely higher utilisation rates at existing plants. This equates to approximately an extra 3.3 million t/a of additional sulphur or sulphuric acid equivalent demand, mainly in North Africa,

and South and Southeast Asia. Saudi Arabia has also recently indicated it will be expanding phosphate capacity via its third Ma'aden development.

Industrial uses

Sulphuric acid has a wide range of industrial uses, from the sulphate process to produce titanium dioxide (which has come to dominate Chinese production) to caprolactam for fibre manufacture, as an alkylation agent in refineries, or the production of other acids like hydrofluoric acid. Because of the wide variety of these uses, industrial acid use is often correlated with general industrial production, which has been one reason for demand growth in China.

The largest single slice of demand comes from extraction of metals from ores, primarily copper, but also nickel, uranium, rare earths and gold. Copper leaching operations are concentrated in Chile, Peru, the USA and southern Africa's copper belt, while Kazakhstan uses large volumes of acid for uranium extraction. But the fastest growing area has been in the nickel industry, where sulphuric acid is used in the high pressure acid leach (HPAL) process to reclaim nickel from abundant but low grade laterite ores in tropical regions. Although the process is notoriously tricky technically, the wave of capacity that came on-stream during the 2010s in Madagascar, New Caledonia, New Guinea, the Philippines and Australia raised acid demand for nickel leaching by 6 million t/a to around 8 million t/a by 2015. High costs and changes in the nickel market precluded new plant developments for several years, but now

a new wave of capacity is under development to feed the growing demand for nickel sulphate for the electric vehicle industry, with Chinese companies backing several new projects in Indonesia, and a number of other projects under development in Australia. PT Halmahera Persada Lygend's 37,000 t/a nickel HPAL plant on Obi Island, Indonesia is due to start up this year after covid related construction delays, while the start-up for PT QMB New Energy Materials 50,000 t/a plant at Morowali has now been pushed back into 2022. Huayou Cobalt also has a plant under development at Morowali, while BASF and Eramet have confirmed they are moving ahead with a joint venture HPAL project at Weda Bay. Vale and Sumitomo are looking at a 40,000 t/a project on Sulawesi from about 2025.

HPAL plants often take a few years to reach capacity, but if all the plants were developed on time and suffered no hitches (albeit an unlikely proposition) the new projects represent up to 5 million t/a of extra acid demand, and hence potentially 1.7 million t/a of sulphur demand by 2026. However, a more likely/conservative estimate would probably be about half of that.

Supply/demand balance

At the moment, new supply from refining and sour gas, taken together, adds about 8 million t/a of new sulphur production capacity out to 2025-6, provided that there are no further project delays, most of it in the Middle East and China, though delays in commissioning and ramp-ups in production may mean that actual volumes of sulphur produced only run at around $\frac{2}{3}$ of

this amount. Additions to refinery sulphur production are projected to be larger than sour gas projects, a turnaround from the past decade. Over the same period, new demand may only reach 5 million t/a, most of it from the phosphate industry. The market is, and continues to be in surplus, at least on paper, but the balance is a fine one, and delays to projects either on the supply or demand side could alter this in any given year.

On a regional basis, the Middle East continues to be the largest exporting region, as new refineries and sour gas projects push additional output much higher than projected demand increases from Saudi Arabia's phosphate processing. North America may run a slight surplus while European supply is looking increasingly tight due to sour gas and refinery closures and run downs.

China has long been the largest national importer of sulphur, but new refineries and sour gas projects may add 2 million t/a of sulphur production over the next five years at the same time that rationalisation continues in the phosphate industry. There is also the question of additional acid production from new smelter capacity which may displace sulphur demand among phosphate producers. However, this may be offset by further closures in China's pyrite-roasting acid sector.

By far the largest variable going forward remains the progress of the coronavirus pandemic, which has the potential to continue to disrupt fuel demand for road vehicles and aircraft (and hence refinery production), and which is still raging at time of writing in Brazil and India, major centres of phosphate demand. ■

CONTENTS

What's in issue 394

COVER FEATURE 1

Sulphur market update

COVER FEATURE 2

India's acid demand

COVER FEATURE 3

SRU revamping

COVER FEATURE 4

Wet gas cleaning

SULPHUR
ISSUE 394
MAY-JUNE 2021



Watch free fertilizer market presentations

Argus deliver concise and insightful webinars analysing the nitrogen, phosphate, potash, sulphur and sulphuric acid markets. The webinars are offered on-demand and live – and are completely free to watch.

Watch the free webinars here:
www.argusmedia.com/webinars



Sulphur 394 | May-June 2021

www.sulphurmagazine.com

BCInsight

Southbank House, Black Prince Road
London SE1 7SJ, England
Tel: +44 (0)20 7793 2567
Fax: +44 (0)20 7793 2577
Web: www.bcinsight.com
www.bcinsightsearch.com

Sulphur in India



PHOTO: BRUKS SWERTELL AB

India's growing economy and population are leading to increased demand for sulphur and sulphuric acid.

Although 2020 saw a contraction in GDP by 10% due to the impact of the coronavirus pandemic, the country had been one of the fastest growing of the world's top 10 economies, with growth of 8.3% in 2016, although this had slowed to 4.1% in 2019. Its population is growing, and it is due to become the most populous country in the world by 2027 according to UN figures, with total population reaching 1.64 billion by 2050. The country thus continues to require more food, leading to rising sulphur/sulphuric acid consumption for the phosphate industry on the one hand, although increasing vehicle use and growth in domestic refining is also leading to some additional sulphur production.

Refining

India is a major importer of crude oil. India's oil demand is expected to rise to 8.7 million barrels per day in 2040 from about 5 million bbl/d in 2019, according to the International Energy Agency (IEA), while its refining capacity will reach 6.4 million bbl/d by 2030 and 7.7 million bbl/d by 2040, from its present 5 million bbl/d. The government has authorised several brownfield projects which are expected to add 1 million bbl/d of additional capacity at existing refineries by 2025, and there are also two major new greenfield refineries under development to add a further 1.2 million bbl/d of capacity.

At the same time, Indian fuel standards continue to tighten, moving to a national

Bharat/Euro-VI standard of 10 ppm maximum sulphur content in April 2020 (some cities, such as heavily polluted Delhi, have already moved to a Euro-VI standard). This is likely to lead to a slow increase in sulphur production over the next two decades. Overall sulphur production stands at just over 1.5 million t/a, but this is slightly complicated by the fact that refineries on the east coast tend to export sulphur to Asia, whereas west coast phosphate producers tend to import sulphur from the Middle East. This means that India is both an exporter and importer of elemental sulphur. The figures in Table 1 show net sulphur production and imports to produce an apparent consumption figure. Demand for sulphur fell 40% to 0.7 million t/a in 2020 due to the impact of the pandemic, which led to a lockdown which closed a number of phosphate fertilizer plants. However, since September demand has begun to pick up again.

Sulphuric acid

India has 71 sulphuric acid plants, although many of them are extremely small and associated with small scale chemical production. India's sulphuric acid production is split between sulphur burning acid plants which run on the domestically generated and imported sulphur, and several metallurgical acid plants associated with base metal smelting; copper, zinc and lead. On the metallurgical acid side, Hindustan Zinc Ltd (HZL) is the largest producer, with production from its lead smelter at Chanderyya, and zinc smelters at Debari and Dariba. Hindustan Copper operates two more acid plants at Khetri and Ghatsila, and Hindalco has three sulphuric acid plants at its Dahej copper smelter at Birla. The Sterlite copper smelter at Tuticorin used to add another large scale acid plant to this, but has been closed down since March 2018 because of alleged environmental breaches.

On the sulphur-burning acid side, most of the plants are associated with downstream phosphate fertilizer production. The Indian Farmers Fertilizer Cooperative (IFFCO) at Paradeep in Orissa is the largest. Other major producers include Paradeep Phosphates Ltd (PPL), Gujarat State Fertilizers & Chemicals Ltd (GSFC), Fertilizers and Chemicals Travancore (FACT) and Coromandel Fertilizers. There is also acid capacity at Mangalore Chemicals and Fertilizers (MCFL) and Khaitan Chemicals and Fertilizers. Outside of fertilizer production, there

Table 1: Indian sulphur and sulphuric acid statistics, million t/a

Year	Sulphur net production	Sulphur imports	Sulphur apparent consumption
2017-18	0.83	1.21	2.04
2018-19	0.89	1.35	2.24
2019-20	0.88	1.24	2.12
Year	Acid production	Acid imports	Acid apparent consumption
2017-18	5.35	1.41	6.76
2018-19	5.72	1.66	7.38
2019-20	5.08	1.98	7.06

Source: Centre for Green Technology and Management

Table 2: Sulphur containing fertilizers, percentage nutrient content by weight

Product	N	S	P ₂ O ₅	K ₂ O
Ammonium sulphate	21	24	-	-
Single superphosphate	-	11	14.5	-
Potassium sulphate	-	17	-	50
Ammonium phosphate sulphate	16	13	20	-
Ammonium phosphate sulphate	20	13	20	-
Elemental sulphur	-	85-98	-	-
Zinc sulphate	-	15	-	-
Ammonium phosphate (S fortified)	13	15	33	-
Magnesium sulphate	-	12	-	-

Source: Fertilizer Association of India

Fig. 1: Domestic Indian production of sulphur-containing fertilizers

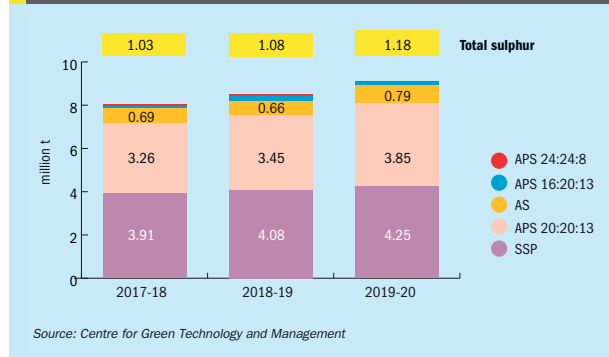

Source: Centre for Green Technology and Management

are some smaller sulphuric acid plants associated with the chemical industry.

Most Indian acid producers import sulphur from the Arabian Gulf region. The major exporters of sulphur into India are Abu Dhabi, Qatar, Oman, Japan, Singapore, Saudi Arabia, Kuwait and Bahrain. Some also import sulphuric acid directly; major acid importers include Coromandel, IFFCO, Greenstar, PPL, FACT and MCFL.

Demand for sulphuric acid in India is projected to increase significantly due to greater production and consumption of phosphate fertilizers in the country, but also increased manufacture of other speciality chemicals such as hydrofluoric acid, titanium dioxide and other pigments and dyes, rayon, as well as lead-acid battery manufacture, use in the pulp and paper industry for chlorine dioxide generation, and several other chemical processes and wastewater treatment and pH control. India's growing population and requirements for food

crops, and base metals for infrastructure investment are expected to increase consumption. Average annual growth to 2025 is projected to average 3.35% year on year.

Fertilizers

India's sulphur consumption is dominated by its use of fertilizers, especially phosphate fertilizers. Table 2 shows the sulphur-containing fertilizers commonly used in India, and most of those are phosphate-based. India is the world's second largest consumer of fertilizers after China; in the 2019-20 application season it used 29.0 million tonnes of nutrient (nitrogen, phosphorus and potassium combined). At the same time, while it is the world's third largest producer of fertilizers, mainly urea and phosphates, it only made 18.5 million tonnes of nutrient (NPK basis) in 2019-20, and had to import 9.9 million tonnes to make up the shortfall, making

it the world's largest importer of fertilizer on a nutrient basis. Consumption has been steadily increasing. Overall domestic production of fertilizers rose 11% in 2019-20 compared to the previous year. The increase was especially marked for DAP, production of which rose 16.7%.

DAP and NP/NPK are the preferred sources of phosphate for Indian farmers. Combined demand for these two product types (19.7 million t/a in 2019/20) equates to around one third of total fertilizer consumption. Currently, India's domestic industry operates 19 diammonium phosphate (DAP) and NP/NPK plants as well as two plants that produce ammonium sulphate (AS) as an industrial by-product. However, almost 50% of DAP and 7-8% of NP/NPK requirements needed to be imported in 2019/20. India also produces large volumes of single superphosphate (SSP) (4.2 million tonnes in 2019/20) for domestic consumption.

Figure 1 shows domestic production of sulphur-containing fertilizers in India over the past three years. As can be seen, while the total volume of sulphur used/incorporated is relatively low, at just over 1 million t/a, this figure continues to rise as India moves towards more balanced application of nutrients, and is likely to continue to do so in future. Prime Minister Modi's government has sought to boost India's self reliance in terms of industrial production. On the urea front that has led to the development of several new plants which could eliminate India's imports of urea – previously the largest import volume in the world – in just a few years. There have been similar moves on the phosphate side, where India also remains a large net importer. New capacity under construction or development includes 400,000 t/a of DAP and other nitrophosphate fertilizers at PPL Paradip, 850,000 t/a of DAP and NP/NPK fertilizers for Green Star Fertilizers at Tuticorin, and 400,000 t/a of DAP at PPL, Odisha. There is also 130,000 t/a of ammonium sulphate capacity due for completion in 2022 at GSFC Vadodara. All of this is likely to boost Indian demand for sulphur and sulphuric acid over the next few years.

Acknowledgements

Sulphur would like to acknowledge the assistance of Dr Sukumaran Nair of Cybene Consultants Ltd and the Centre for Green Technology and Management, Cochin, India, for his kind help in the preparation of this article.

www.sulphurmagazine.com

CONTENTS

What's in issue 394

COVER FEATURE 1

Sulphur market update

COVER FEATURE 2

India's acid demand

COVER FEATURE 3

SRU revamping

COVER FEATURE 4

Wet gas cleaning

SULPHUR
ISSUE 394
MAY-JUNE 2021

BCInsight

Southbank House, Black Prince Road
London SE1 7SJ, England

Tel: +44 (0)20 7793 2567

Fax: +44 (0)20 7793 2577

Web: www.bcinsight.com
www.bcinsightsearch.com

Sulphur recovery projects 2021

Sulphur's annual survey of recent, current and future sulphur recovery unit construction projects maps the developing shape of brimstone production from fuel and gas processing plants worldwide.

Operating company	Operating site	Process type	Total new capacity	Licensor(s)	Lead contractor	Project type	Planned startup date
ALGERIA							
Sonatrach	Hassi Messaoud	Claus, TGT, amine, SWS	14 t/d	n.a.	Wood Group	New	2024
AZERBAIJAN							
SOCAR	Baku HAOR	Claus, TGT, amine H ₂ S/CO ₂ removal	2 x 30 t/d	Tecnimont, UOP Wood Group	Wood Group KT-Kinetics Tech.	New	2021
BAHRAIN							
Bapco	Sitra Refinery	Claus, NH ₃ , amine, SWS, AGRU	3 x 250 t/d	Comprimo	n.a.	New	2022
BRAZIL							
Petrobras	Belo Horizonte	SuperClaus	2 x 62 t/d	Comprimo	n.a.	Revamp	2020
Petrobras	Mariim	AGRU	n.a.	n.a.	n.a.	New	2023
CANADA							
Pembina-Veresen	Hythe	SuperClaus	2 x 310 t/d	Comprimo	n.a.	New	2021
Pembina-Veresen	Two Lakes	SuperClaus	2 x 62 t/d	Comprimo	n.a.	Revamp	2020
PetroCanada	Fort Hills Upgrader	Claus, NH ₃ , amine	2 x 700 t/d	Comprimo	n.a.	New	On hold
IOL	Nanticoke Refinery	EuroClaus	127 t/d	Comprimo	n.a.	Revamp	2022
Encana	Pipestone Gas Plant	Sulfinol M	n.a.	Comprimo	n.a.	New	2021
Veresen Midstream	Hythe Gas Plant	Claus, SuperClaus, degas	265 t/d	Comprimo	n.a.	Revamp	2021
CHINA							
ExxonMobil	Huizhou	SuperClaus, caustic	2 x 81 t/d	Comprimo	n.a.	New	2023
COLOMBIA							
EcoPetrol	Barrancabermeja	Claus, NH ₃ , amine	2 x 130 t/d	Comprimo	n.a.	New	On hold
EcoPetrol	Barrancabermeja	Claus	90 t/d	Siirtec Nigi	n.a.	Revamp	2020
CROATIA							
INA	Rijeka	Claus	95 t/d	Comprimo	n.a.	New	2020
CZECH REPUBLIC							
Unipetrol	Litvinov	Degas	220 t/d	Comprimo	n.a.	Revamp	2021
EGYPT							
ASORC	Asyut	Claus, HCR, TGT	2 x 130 t/d	Siirtec Nigi	TechnipFMC Petrotet	New	2022
Eni	Zohr	Claus, acid gas enrich, TGT, degas	4 x 12 t/d	KT-Kinetics Tech.	Petrobrel	New	2021
FRANCE							
Total	Donges	SWS	n.a.	Wood Group	Wood Group	New	2021
GREECE							
Hellenic Petroleum	Thessaloniki	Claus, TGT, degas	40 t/d	Siirtec Nigi	n.a.	New	2020

KEY
 AGRU = Acid gas removal unit
 BTX = BTX destruction
 Fuel = Fuel gas supplemental burning
 H₂ = Hydrogenation
 O₂ = Oxygen enrichment
 NH₃ = Ammonia destruction
 SRU = Sulphur recovery unit
 SWS = Sour water strip
 TGT = Tail gas treatment unit
 n.a. = Information not available

Operating company	Operating site	Process type	Total new capacity	Licensor(s)	Lead contractor	Project type	Planned startup date
INDIA							
HPCL	Vishakhapatnam	Claus, SCOT	2 x 450 t/d	Comprimo	Petrofac	New	2022
IOCL	Panipat	Claus, LT-SCOT	465 t/d	Comprimo	n.a.	New	2022
IOCL	Panipat	Claus, TGT	225 t/d	Axens	n.a.	New	2020
IOCL	Mathura	Claus, TGT	2 X 425 t/d	Axens	n.a.	New	2020
IOCL	Bongaigon	Claus, TGT	20 t/d	Axens	n.a.	New	2020
INDONESIA							
Pertamina	Balongan	Claus, NH ₃ , H ₂ , amine TGT	1,100 t/d	Wood Group	n.a.	New	n.a.
Pertamina Rosneft	Tuban	Claus, LT-SCOT amine, SWS	2 x 1,040 t/d	Comprimo	n.a.	New	2022
IRAN							
Ilam Petchem	Ilam	Claus	27 t/d	Axens	EIED	New	2020
IRAQ							
Turkish Pet Int	Mansuriyah	Claus, amine	230 t/d	Comprimo	n.a.	New	2021
ISRAEL							
PAZ Ashdod Refinery	Ashdod	Degas	44 t/d	Comprimo	n.a.	New	2022
ITALY							
Eni	Melitah	Claus, TGT	n.a.	Siirtec Nigi	n.a.	Revamp	2021
JAPAN							
JXTG	Mizushima	SuperClaus	2 x 175 t/d	Comprimo	n.a.	Revamp	2020
JXTG	Kawasaki	SuperClaus	2 x 146 t/d	Comprimo	n.a.	Revamp	2020
JORDAN							
JPRC	Zarqa	Claus, SCOT	2 x 250 t/d	Comprimo	n.a.	New	2021
KUWAIT							
KNPC	Al Zour Refinery	Claus	1,500 t/d	Wood Group	Comprimo	New	2020
KNPC	Mina al Ahmadi	Claus, amine, TGT	2 x 400 t/d	Comprimo	n.a.	New	2020
MALAYSIA							
MRC	Melaka	SuperClaus	220 t/d	Comprimo	n.a.	New	2021
Sarawak Shell	Sarawak	SuperClaus	166 t/d	Comprimo	n.a.	New	2022
MEXICO							
PEMEX	Cadareyta	SmartSulf, NH ₃	132 t/d	Comprimo	n.a.	New	On hold
PEMEX	Dos Bocas Refinery	EuroClaus, degas	2 x 640 t/d	Comprimo	n.a.	New	2022
NETHERLANDS							
Total/Lukoil	Zeeland	SWS	n.a.	Wood Group	Wood Group	Revamp	2020
BP Raffinaderij	Rotterdam	Claus, LT-SCOT, SWS	2 x 100 t/d	Comprimo	n.a.	New	2022
Shell Raffinaderij	Rotterdam	AGRU, SWS	n.a.	Comprimo	Worley	New	2023
OMAN							
OOC	Duqm Refinery	Claus, H ₂ , SWS, amine	3 x 355 t/d	Comprimo	Tecnicas Reunidas	New	2022
PERU							
Repsol	La Pampilla	2 x Claus, NH ₃ , O ₂ , H ₂ , amine, TGT	37 t/d	Wood Group	n.a.	New	n.a.
POLAND							
PKN Orlen	Plock	Claus, BSR	393 t/d	Comprimo	n.a.	New	2022

KEY
 AGRU = Acid gas removal unit
 BTX = BTX destruction
 Fuel = Fuel gas supplemental burning
 H₂ = Hydrogenation
 O₂ = Oxygen enrichment
 NH₃ = Ammonia destruction
 SRU = Sulphur recovery unit
 SWS = Sour water strip
 TGT = Tail gas treatment unit
 n.a. = Information not available

CONTENTS

What's in issue 394

COVER FEATURE 1

Sulphur market update

COVER FEATURE 2

India's acid demand

COVER FEATURE 3

SRU revamping

COVER FEATURE 4

Wet gas cleaning

SULPHUR
ISSUE 394
 MAY-JUNE 2021

BCInsight

Southbank House, Black Prince Road
 London SE1 7SJ, England
 Tel: +44 (0)20 7793 2567
 Fax: +44 (0)20 7793 2577
 Web: www.bcinsight.com
 www.bcinsightsearch.com

Operating company	Operating site	Process type	Total new capacity	Licensor(s)	Lead contractor	Project type	Planned startup date
RUSSIA							
Bashneft	Ufa	Amine, SWS	n.a.	Wood Group	n.a.	New	2023
Lukoil	Kstovo	Claus	240 t/d	KT-Kinetics Tech.	KT-Kinetics Tech.	New	2021
Slavneft	Yanos Refinery	Claus, TGT	2 x 133 t/d	Siirtec Nigi	n.a.	New	2021
Rosneft	Saratov	EuroClaus	283 t/d	Comprimo	UOP	New	2020
Taneco	Nizhnekamsk	Claus, TGT	3 x 410 t/d	Comprimo	n.a.	Revamp	2020
Gazpromneft	Moscow	Claus	n.a.	KT-Kinetics Tech.	Saipem	New	2020
SAUDI ARABIA							
PetroRabigh	Rabigh	EuroClaus	3 x 292 t/d	Comprimo	KT-Kinetics Tech.	New	2020
Saudi Aramco	Tanajib Gas Plant	Claus, O ₂ enrich, amine	3 x 1,000 t/d	Comprimo	Tecnicas Reunidas	New	2021
Saudi Aramco	Fajurah Gas Plant	Claus, O ₂ enrich, amine	3 x 350 t/d	Comprimo	Samsung	New	2021
Saudi Aramco	Fadhili Gas Plant	n.a.	6 x 667 t/d	Wood Group	Petrofac	New	2020
Saudi Aramco	Khursaniyah Gas Plant	O ₂ enrichment	5 x 1037 t/d	Comprimo	n.a.	Revamp	2021
SAMREF	Yanbu Al Sinayah	Claus, Flexsorb	2 x 480 t/d	Comprimo	n.a.	New	2022
SERBIA							
NIS	Pancevo Refinery	Claus, NH ₃ , amine	170 t/d	Comprimo	n.a.	Revamp	2020
SINGAPORE							
SRC	Jurong Island	Claus, O ₂ enrich, NH ₃	145 t/d	Comprimo	n.a.	Revamp	On Hold
ExxonMobil	Pulau Ayer	SuperClaus	400 t/d	Comprimo	n.a.	New	2020
Linde Gases	Jurong Island	Claus, amine	undisclosed	Comprimo	n.a.	New	2022
SOUTH AFRICA							
Chevron	Cape Town	Claus, SCOT	2 x 45 t/d	Comprimo	Fluor	Revamp	2020
THAILAND							
Thai Oil	Sriracha Refinery	Claus, NH ₃ , Flexsorb	2 x 837 t/d	Comprimo	Wood Group	New	2021
TURKEY							
Tupras	Izmir	Degas	240 t/d	Comprimo	n.a.	New	2020
Tupras	Izmit	EuroClaus	240 t/d	Comprimo	n.a.	New	2020
Tupras	Kirikale	EuroClaus	135 t/d	Comprimo	n.a.	New	2020
TURKMENISTAN							
Turkmenbashi Oil	Turkmenbashi City	SuperClaus	25 t/d	Comprimo	Hyundai	New	Delayed
UGANDA							
AGRC	Kaabale	Claus, HCR	7 t/d	Siirtec Nigi	n.a.	New	2023
UNITED ARAB EMIRATES							
ADNOC	Shah	Claus, Flexsorb	4 x 3,368	Comprimo	n.a.	Revamp	n.a.
ADNOC	Shah	n.a.	4 x 1,250 t/d	Fluor	Wood Group	New	2023
Takreer	Ruwais	n.a.	n.a.	n.a.	Wilson Engineering	Revamp	2021
UNITED STATES VIRGIN ISLANDS							
Limetree Bay Terminals	St. Croix	Degas	2 x 200 t/d	Comprimo	n.a.	Revamp	2020
UZBEKISTAN							
Mubarek	Mubarek Gas Plant	Claus, amine	1,000 t/d	Comprimo	n.a.	New	2020
VIETNAM							
ExxonMobil	Ca Voi Xanh	Claus, TGT, caustic	87 t/d	Comprimo	n.a.	New	2023

KEY
 AGRU = Acid gas removal unit
 BTX = BTX destruction
 Fuel = Fuel gas supplemental burning
 H₂ = Hydrogenation
 O₂ = Oxygen enrichment
 NH₃ = Ammonia destruction
 SRU = Sulphur recovery unit
 SWS = Sour water strip
 TGT = Tail gas treatment unit
 n.a. = Information not available



PHOTO: SIPA/US/ALAMY

Smelter acid in East Asia

Metal processing in Northeast Asia is the major source of sulphuric acid exports from the region, and the ramp up of Chinese copper smelter capacity is leading to increased acid availability.

Above: Melting copper scrap at the Tongling Nonferrous Metals copper smelter in Tongling, China.

The major centres of sulphuric acid exports are Europe and northeast Asia. Korea and Japan in particular are the two largest individual exporters of sulphuric acid in the world, mainly from involuntary production in copper and other base metal smelting operations. But China's rapid industrialisation has also seen it rapidly increase its smelter acid production and turn it into a net exporter of acid in the past few years.

Japan

Copper produces most – about two thirds – of Japan's sulphuric acid output. There are seven major copper smelters in Japan, at Tamano, Sagane, Naoshima, Hitachi, Onohama, Kosaka

Fig. 1: Copper smelter capacity worldwide, 2019

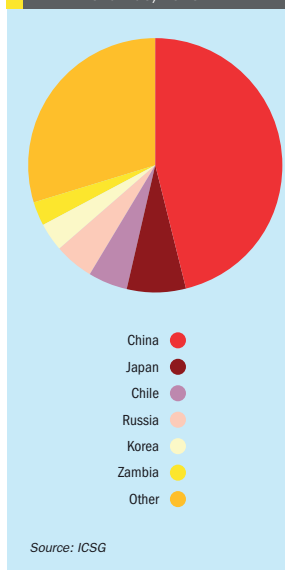



PHOTO: SMM

Sumitomo Metal Mining's Toyo smelter, Japan.

and the Sumitomo Toyo copper smelter. The largest is the Pan Pacific Copper smelter at Saganoseki, with an output of 1.5 million t/a, although Sumitomo Toyo also has capacity of just short of 1.5 million t/a. Other large smelters include Tamano, which has capacity to produce 890,000 t/a of sulphuric acid, and Onahama in Fukushima, with 600,000 t/a of acid capacity. There are also several smaller zinc and lead smelters, including Toho Zinc at Onohama with another 150,000 t/a of output, and the Sumitomo/Dowa Akita zinc smelter can produce 300,000 t/a of acid.

Japanese production of sulphuric acid in 2019 was 6.23 million t/a, down from 6.54 million t/a the previous year and down further from a peak in 2010 of 6.9 million t/a. Nevertheless, Japanese exports of acid are generally fairly stable between 2.5 and 3.0 million t/a of acid.

Japan's acid output remains tied to the fortunes of the copper market. However, Japanese refined copper production actually rose by 7% during 2020 in spite of the covid pandemic, boosting acid output slightly accordingly. Predictions for 2021 are for a slight decline in copper output, perhaps of the order of 2%. Sumitomo Metal Mining says that its output from April 2021-March 2022 will be down 6% from 450,000 t/a for the previous financial year because of planned maintenance in October. Mitsubishi Materials (MMC) expects its copper output to fall by 8% – production at the 300,000 t/a Onahama copper has been restricted since January because of an oxygen plant issue. The Naoshima smelter is also expected to reduce output because of maintenance. However, zinc and lead output will rise slightly; Mitsui Mining & Smelting is planning to increase zinc and lead output following a major

maintenance shutdown at the Hachihone smelter in 2020.

South Korea

As with Japan, production is concentrated in a few large smelters, though with zinc more of a feature than copper. Korea Zinc's smelter at Onsan produces 1.0 million t/a of sulphuric acid, while the LS Nikko copper smelter at the same site produces 1.36 million t/a of acid. Youngpoong has 550,000 t/a of output from its zinc roaster at Seokpo, and Namhae Chemical company also has 890,000 t/a of sulphur burning acid capacity at Yeosu. Although overall production is smaller than Japan, demand is also, and South Korea has a surplus of about 2.8 million t/a of sulphuric acid production.

Korea likewise increased copper output during 2020, although zinc output fell over the year. Zinc production is also expected to be down slightly in 2021 as the Yoongpoong zinc smelter at Seokpo is facing a two month shutdown mandated by the authorities for breaches of the Water Environment Conservation Act. Situated in a national park, the Seokpo smelter is alleged to have discharged waste from the smelting process into the local river, which is used for drinking water by millions of people. The smelter has also faced previous trouble for falsifying air quality data.

Japan and South Korea between them represent about one third of all sulphuric acid exports. Chile is the largest destination for northeast Asian acid, to feed copper leaching there, along with other regional markets in east and southeast Asia such as India, Thailand, Malaysia and Indonesia. Sumitomo also transfers about 500,000 t/a of acid from Japan to its nickel leaching plant at Coral Bay in the Philippines.

China

Chinese sulphuric acid output has been growing rapidly, mainly due to the rapid expansion of non-ferrous metal smelting. Asia's share of world copper smelter output jumped from 27% in 1990 to 65% in 2019 as smelter production in China expanded. Figure 1 shows just how much of the world's copper smelting capacity has come to be represented by Chinese production. According to the China Sulphuric Acid Industry Association, China's total sulphuric acid capacity was 124 million t/a in 2019, up 2.1% from the previous year. Sulphur burning acid capacity represented 53 million t/a of this, down 1.1%, while smelter acid capacity was 44 million t/a, up 6.2% on the previous year. The remaining 23 million t/a was represented by pyrite roasting.

With an average operating rate of 79%, total Chinese acid production in 2019 was 97.4 million t/a, up 0.5%, with smelter acid representing 37.4 million t/a of this, up 7% on 2018's figure. Rising smelter acid production displaced some sulphur burning output, which fell by 6% to 41.7 million t/a in 2019, and has also led to shutdowns among pyrite roasters in the country. Smelter acid operating rates averaged 85% for the year.

Overall acid consumption in China was 95.7 million t/a, down 0.8% on 2018, as output from phosphate fertilizer plants fell due to environmental-related closures. However, industrial acid consumption, used in industries such as titanium dioxide, hydrofluoric acid, caprolactam, citric acid, iron and steel, and textiles, represented 41.0 million t/a of overall consumption (43%) and rose 2.1% year on year. Titanium dioxide is a major consumer, and required 11.4 million t/a of acid in 2019.

In 2019, China exported 2.2 million t/a of sulphuric acid, 70% up on the previous year. Imports were down to 530,000 tonnes, 90% down on 2018, contributing to a net increase in Chinese acid exports by 1.3 million t/a. Major destinations were Morocco, Chile and India, accounting for 80% of all exports between them. The wave of Chinese acid in 2019-20 helped push down global prices.

New smelter production

China continues to bring new smelter acid production online. In 2019 a total of 8.7 million t/a of new sulphuric acid capacity came on-stream in China, most of it smelter-based,

and the China Nonferrous Metals Industry Association says that over the period 2019 to 2023 new acid capacity will total 23.1 million t/a, of which 19.2 million t/a – more than 80% – will be from smelting, mainly in Hubei, Inner Mongolia, Guangxi, Gansu and Shandong provinces. However, CNIA expects smelter output to peak in the period.

The investment in smelter acid capacity is based on rapidly increasing copper demand in China. China already represents half of all copper consumption, and its status as the main manufacturing centre for domestic appliances as well as a need for new electric power cabling is driving new demand. Chinese manufacturing has rebounded quickly after a dip caused by the pandemic in early 2020. According to the ICSG, world demand for refined copper was down 9% in 2020 because of the pandemic, but will grow by about 6% in 2021, with China driving much of the increase.

Even so, this rapid increase in smelter capacity has begun to have negative effects for the industry as a whole. Copper mine output has been falling globally for a couple of years, with new mine start-ups delayed by the pandemic, and covid-related shutdowns affecting output from Peru and Chile in 2Q 2020. Indonesia has clamped down on exports of copper concentrate to try and encourage its own domestic processing industry, and in China a souring relationship with Australia has led to a de facto ban on copper concentrate imports from there since December 2020. Coupled with issues in supply from Chile, copper concentrate has come to be in increasingly short supply in China, which in turn has driven down smelter treatment charges (TCs) – the amount that smelters charge suppliers of concentrate for processing it into refined copper. Indeed, these fell to as low as \$29/t in March 2021; a 10 year low, squeezing smelter margins considerably. Benchmark TCs for 2021 had been set at \$59.50/tonne, already the lowest since 2011. Chinese smelters failed to collectively agree a minimum TC level for 2Q 2021, a sign of how competitive the market for copper concentrate has become.

With smelter margins badly squeezed, some relief has come from rising sulphuric acid prices, for both copper and zinc smelters. Acid prices increased substantially in March across China, with some producers achieving prices of \$70/t for March against \$45/t a month previously. Others however were seeing offtake prices as low as \$30/t. With smelter output running at high levels, there is a lot of sulphuric acid being generated and stocks are running high.

The result is that many Chinese copper smelters have brought forward maintenance plans or reduced raw material use. Goldman Sachs estimates that 700,000 t/a of capacity will be affected in April, 2.0 million t/a in May and a further 900,000 t/a in June. This would represent cumulatively a loss of around 200-250,000 tonnes of refined copper, and each tonne of copper represents 3 tonnes of sulphuric acid generated from off-gases.

Nor is this confined to China. Global copper smelting activity slipped to its lowest in at least five years in March, according to LME broker Marex Spectron in spite of copper prices reaching a 10 year high of \$9,600/t in February.

'Urban mining'

With mined output tight, there has been a turn towards recycling of copper scrap in China. Recycled copper makes up around 30% of the copper market, and is usually remelted by refiners, although obviously without releasing the SO₂ that copper concentrate does, and hence without increasing acid production.

China had become the world's largest importer of scrap copper, running at 300,000 tonnes per month by 2017. But this had been

falling, dropping to 1.49 million t/a in 2019. Attempts by government to end China's status as a dumping ground for the world's waste had led to tightening restrictions on the purity of imported metallic waste, and in 2020 the amount of waste copper imported fell again, to 0.94 million t/a, as the country aimed for a blanket ban on solid waste imports. But now the lack of availability of concentrate has led the government to delay and relax these restrictions and copper scrap imports leapt by 60% in the first months of 2021.

One issue has been availability of scrap copper – copper scrap availability is very much driven by price. Globally, copper secondary refined production (from scrap copper) declined by 5.5% in 2020 due to a shortage of scrap metal in many regions, according to the International Copper Study Group (ICSG), with decreased scrap generation, collection, processing, and transport resulting from the global lockdown. However, higher prices incentivise the collection and processing of end-of-life scrap, and the run up of copper prices in late 2020 and early 2021 is likely to mean more becoming available.

Elsewhere, Japan has also been increasingly turning to 'urban mining' – recycling raw materials from scrap metals, for environmental reasons, with the upcoming Tokyo Olympics driving one initiative, to recycle consumer electronics to produce the copper to make the bronze for medals. Margins tend to be lower due to the cost of sorting and retrieval of the metals, much of which must be done by hand, but companies such as Sumitomo are building facilities for recycling of lithium ion batteries into copper, cobalt and nickel, and the move to electric vehicles will increase the pressure to recycle automotive batteries. ■



An ITT Brand

Pumps specialist for the sulphur industry

Rheinhütte Pumpen supplies chemically resistant centrifugal pumps to handle molten sulphur and sulphuric acid. Optimal customer and engineering solutions are provided in a large selection of more than 30 metal and plastic materials combined with special shaft seals.



ITT RHEINHÜTTE Pumpen GmbH
 Rheingaustraße 96-98 | D-65203 Wiesbaden | www.rheinhuette.de

CONTENTS

What's in issue 394

COVER FEATURE 1

Sulphur market update

COVER FEATURE 2

India's acid demand

COVER FEATURE 3

SRU revamping

COVER FEATURE 4

Wet gas cleaning

SULPHUR
ISSUE 394
 MAY-JUNE 2021

BCInsight

Southbank House, Black Prince Road
London SE1 7SJ, England

Tel: +44 (0)20 7793 2567

Fax: +44 (0)20 7793 2577

Web: www.bcinsight.com
www.bcinsightsearch.com

A safer and efficient way to cool strong sulphuric acid

N. Clark, B. Avancini and V. Sturm of

Clark Solutions discuss a novel technology, SAFEHX®, providing a new approach to the cooling of strong sulphuric acid. Prototype results are shown and indicate a safe and stable cost-effective technology. SAFEHX® can be extended to every heat exchanger system where corrosion, mixture risks, fouling, process liquid loss (or contamination) and temperature control are key concerns.

Fig. 1: Basic SAFEHX® operating scheme

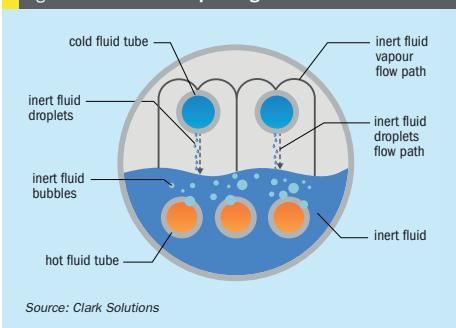

Strong acid cooling and energy recovery is fundamental for sulphuric acid plants. Although strong acid cooling coupled with energy recovery is still not a widespread practice, since the 1980s interest in it has been growing. Some proven technologies have been employed, but associated added risks limited the acceptance and proliferation of these technologies. Recently, Clark Solutions developed a new technology to remove these added risks and a 150 t/d acid plant already operates with a SAFEHR® heat recovery system – a patented inert trim cooler technology that can substitute conventional heat exchangers systems, reducing corrosion and hydrogen incident risks with the benefit of energy recovery. Another SAFEHR® system was supplied to a 3,200 t/d plant under construction.

With focus on innovation, Clark Solutions' interest in enhancing process capacity and efficiency using cost-effective approaches motivated a further development, SAFEHX®. This novel technology is discussed in this article and uses the SAFEHR® trim cooler approach while shifting from sensible to latent heat and merging both heat exchangers into a single

device. Along its development, SAFEHX® showed a set of advantages besides the intended increase in cost-effectiveness. An innate temperature control and extreme fouling resistance are characteristics that also enable the use of this technology in other industries besides sulphuric acid. This temperature control is the consequence of a pressure dominant system, since shell buffer fluid operates in a boiling-condensing regime, hence cold fluid will never heat above a set buffer temperature.

While SAFEHR® shows versatility in safe use ramifications (BFW heating, steam production, service water heating, conventional cooling, among others), SAFEHX® shows a compact and precise approach for safe heat transfer systems.

The SAFEHX® approach

SAFEHX® is the concept of cooling hot acid, or other fluids, in a single three-fluid heat exchanger with a mutually inert fluid acting as a buffer fluid inside the shell. This design has a shell, and two or more sets of tube bundles. Bottom, submerged tubes provide heat to boil the buffer fluid, in opposition to

the upper, emerged tubes, that retrieve heat and condense back this buffer fluid.

Buffer fluid flow inside the shell is generated by this boiling-condensing regime. Its fundamental purpose is to increase safety and reliability in heat transfer using a compact device enabled by latent heat, minimising damage due to mixing cold and hot fluid, and eliminating hydrogen generation and accumulation in the event of leak-associated corrosion.

Additional benefits were also identified and will be discussed later in this article. Fig. 1 shows a basic SAFEHX® scheme.

The SAFEHX® system comprises a single heat exchanger using a properly selected inert fluid as a buffer. In sulphuric acid plant applications, hot acid is cooled in the bottom tubes by boiling the inert fluid, the vapours flow upwards and are condensed by heating boiler feed water (BFW) and/or another fluid.

Flow direction is not a concern for either set of tube bundles, reducing connection and piping interferences. The equipment does not require shell baffles, facilitating manufacturing and maintenance and reducing costs.

Fig. 2: Conventional acid cooling (rejecting heat to cooling water)

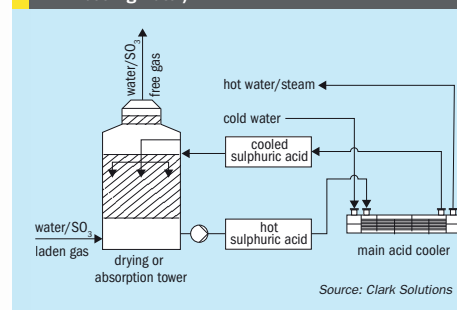

SAFEHX® can be used on a conventional acid cooling system or attached to a heat recovery tower as a safety and reliability improvement.

Fig. 3 shows how SAFEHX® would be integrated with the absorption tower and a prompt conclusion is that almost no change is required to install the equipment.

Inert fluid

In the early 2000s Clark Solutions carried out development, extensive testing and evaluation of direct cooling of sulphuric acid by mixing with inert fluids. During this research a few families of fluids were found to have adequate properties:

- Stability: fluid can withstand processing temperature and pressures.
- Inertness: fluid must be inert to both hot and cold fluids, in this case, acid and water.
- Flammability: fluid had to be non-flammable.
- Toxicity: totally non-toxic.
- Corrosivity: fluid cannot be corrosive to steel and other alloys.
- Safe to handle: minimal or no handling or storage special requirements.
- Density: fluid density better to be in-between water and acid densities.
- Heat transfer: good heat transfer properties.

The direct contact approach failed; the amount of fluid required was substantially high, fluid final temperature would be much lower than the acid temperatures, impeding any heat recovery, and the potential loss of fluid due to acid carryover on the acid stream could be costly.

While direct cooling did not prove to be commercially attractive, using the inert

Fig. 3: SAFEHX® acid cooling (heat transferred to cooling water, BFW or others)

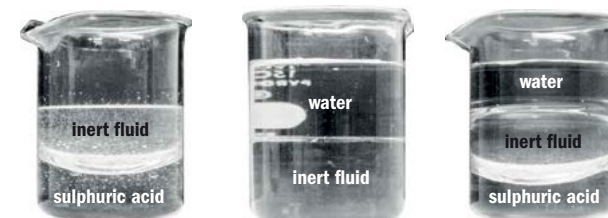
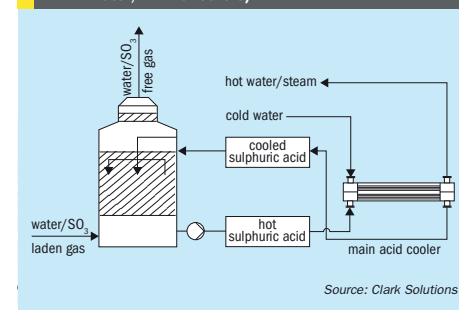

Fig. 4: Immiscibility and inert aspect.

fluid provided an excellent approach for a trim cooling system and hence enabled SAFEHR® development.

For SAFEHX®, a similar set of characteristics was important, but different vapour pressures would be required to use the latent heat approach. But for different vapour pressures, the system would only require operating with different controlled pressures. This highlighted the potential benefit of high temperature control.

Different processes may use different buffer fluids which better interact with process-specific hot and cold fluids.

Safety and hydrogen incidents

On a conventional acid cooling system in a plant that does not recover energy, the flow through the acid coolers is undertaken in a condition that acid pressure is always higher than the cooling water pressure. Typically, in the event of a failure, acid will leak into the water side allowing identification by measuring water pH downstream of the coolers and avoiding dilute acid formation inside plant equipment. But leaks will heavily damage heat transfer equipment, contaminate water cooling system, and require a plant shutdown that may last from days

to weeks, depending on the leak extent and response time.

On a heat recovery system, acid is always at a lower pressure than boiling water, which is pressurised up to 10 bar, depending on steam quality requirements. The large pressure difference between acid and water is a stronger driving force than the pressure difference in a conventional system. Therefore, a leak either initiated by corrosion, bad material and workmanship quality or even a stress issue will occur at substantially higher flow rates than that in a conventional system. Consequently, acid dilution and heat release rates will become higher, ultimately leading to critical failures.

Additionally, this leak region receives hot acid at 180+°C mixed with hot water to produce a dilute acid at even higher temperatures. Local conditions are tremendously aggressive.

Studies of dilution induced corrosion progression developed by Clark Solutions show that corrosion rates of a 1 mm hole in an acid-water system at ambient temperature and pressure can be as high as 150 mm per year, with the hole diameter growing as much as 0.1% per hour in these mild conditions.



Fig. 5: 316L plate (Left: in acid/inert fluid system. Right: in acid/water system – a hole was used to mix fluids representing a mild leak.)

Using an inert fluid greatly reduces corrosion rates, even if a leak occurs. Table 1 shows results measured from these corrosion tests.

When in a heat recovery system, a water leak into the acid will dilute the strong acid in the system. The corrosion effects will occur inside acid plant equipment and hydrogen will accumulate in high spots. Several hydrogen explosions have been reported by the industry in the recent past.

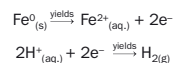

Several actions and measures have been taken to minimise the risk of a disastrous failure in a heat recovery system due to leaks of hot, high-pressure water into acid.



Fig. 6: SAFEHX physical experimental bench.

Table 1: Sulphuric acid corrosion progression on leaking hole		
Fluid Pair	Conditions	Results
Water 98% sulphuric acid	12 hours duration Start at ambient temperature 316L stainless steel apparatus	Corrosion rate: 145 mm/year Mass lost: 0.1% per hour
CS270 inert fluid 98% sulphuric acid	72 hours duration Start at ambient temperature 316L stainless steel apparatus	Corrosion rate: nil Mass lost: nil

Source: Clark Solutions

From modern, sophisticated, and redundant concentration, corrosion and temperature digital monitoring and control to segregated heat recovery towers have been employed to reduce emergency shutdown probability. Advances in instrumentation have also substantially reduced risks with monitoring and safety measures. However, none of these safety schemes eliminate the root cause of the failure: acid-water contact. SAFEHR®, and now SAFEHX®, will never allow acid and water to mix.

Prototype

To ensure that Clark Solutions' products are always functional and can be used on an industrial scale, a clear and direct methodology is followed. For this new product, a rigorous numerical study was carried out

to size the prototype, using heat and mass transfer models.

Using the obtained results from this numerical study, Clark Solutions' engineering team carried out a mechanical project, an experimental bench setup and an automation system aiming for a validation through quantitative results.

The experiment bench is presented in the Fig. 6. In its concept there were: two pumps, two volumetric flow meters, five thermistors and three pressure transmitters. All the bench control and data acquisition were held by the PLC and a supervisor system. The supervisor system was operated through a computer in which bench control was undertaken.

With the basic flow diagram of the bench in Fig. 7, we see that it has two closed-loop water cycles. One is called the cold-water

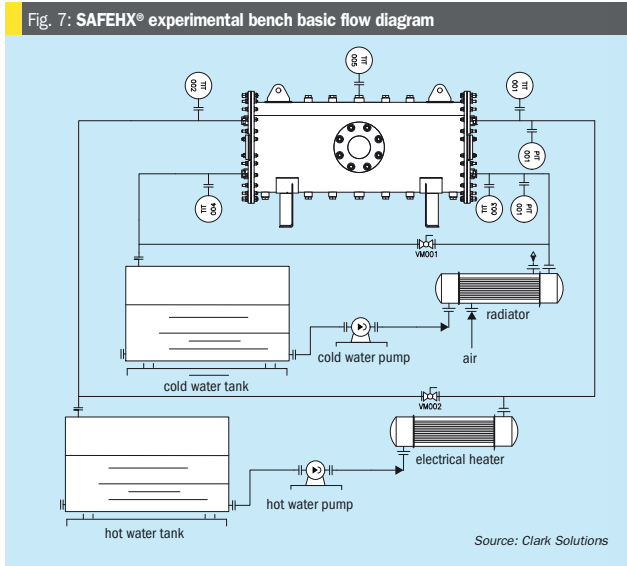

Fig. 7: SAFEHX experimental bench basic flow diagram



Fig. 8: SAFEHX working behaviour.

loop. This loop has a tank, a pump, a flow control valve, one pressure transducer, two temperature transducers and one air radiator, to decrease water temperature. The other is the hot-water loop. This loop also has a tank, a pump, a flow control valve, one pressure transducer, two temperature transducers, but it has a heat resistance instead of the air radiator, to increase water temperature.

Experimental results

After several experimental bench tests to ensure that the instrumentation and system were working as expected it was possible to execute some prototype runs to verify the heat transfer capacity. As first evidence of the heat transfer phenomena, there is the visual of both boiling and condensation processes inside the heat exchanger shell. The boiling is verified by the froth which hides the submerged tubes, and the condensation is verified by the uniform dripping from the emerged tubes. Fig. 8 shows a very disturbed liquid surface caused by vapour bubbles and an intense flow of droplets dripping from the emerged tubes.

It is also worth mentioning the inert fluid buffer effect. As the temperature control system of the hot loop generates oscillations in the hot fluid temperature, it is possible to

verify in Fig. 9 that no oscillatory behaviour is presented in the cold loop temperatures. This shows the high capacity of damping eventual temperature changes of a hot loop circuit and maintaining the heat transfer stable for the cold loop circuit. This is an important feature for processes that need to maintain heat exchanger performance with the safety of not crossing a minimum or maximum temperature.

As can be seen in Fig. 9, the buffer liquid maintains a constant temperature controlled by the SAFEHX shell pressure setting point, which dominates the buffer liquid temperature. Even with oscillations on the hot fluid inlet, the cold fluid temperatures are stable. The system proved to be not only a safe means for heat transfer, but also an excellent system to control temperature.

An overview of the heat transfer can be seen in Fig. 10, which further illustrates the dampening effect caused by the buffer fluid-controlled temperature.

The system was tested with varying heater output to change the hot fluid inlet temperature over time. The excess heat was subsequently transferred to the buffer fluid with some heat lost to the surroundings (not a perfectly adiabatic shell as observed from the gap between lines). This transferred heat from the hot liquid to the SAFEHX system can be seen in the red lines of Fig. 10. But the erratic buffer liquid energy intake from

the hot loop did not necessarily cause cold fluid to behave as erratically, this may seem contradictory at first, but this occurs due to internal energy variations of the buffer liquid which dampen system temperature variations. Blue lines have plateaus which are caused by changes in cold liquid flowrate and not differences in cold fluid temperatures.

Fouling resistance

Shell interiors and tube fins are typically difficult to maintain and clean, a problem that would never occur for the SAFEHX heat exchanger.

Several heat transfer applications have fouling as a major concern for design and operation, as a consequence of either temperature-induced precipitation or feed particle content. As the buffer liquid does not have fouling characteristics and the shell is a closed-circuit, no material may precipitate or enter to cause fouling in the shell side.

SAFEHX can also make use of finned tubes, giving a significant increase in area in a place where no fouling can occur, the shell side. Fouling can only occur inside pipes, and cleaning inside pipes is an easy and fast solution for the SAFEHX even for high fouling systems.

Notwithstanding, this fouling inside pipes is also mitigated for operations where denaturation and precipitation concerns for the cold fluid are present, since the system shows an innate high precision temperature control for both buffer and cold fluid as shown above, reducing precipitation due to process oscillations.

Product loss and contamination

With a closed buffer fluid on shell side, any leaks of process fluid will not be carried away. In conventional heat exchanger systems, a leak will cause the fluid with more pressure to leak into the current with lower

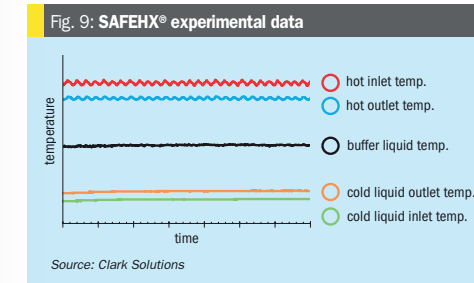

Fig. 9: SAFEHX experimental data

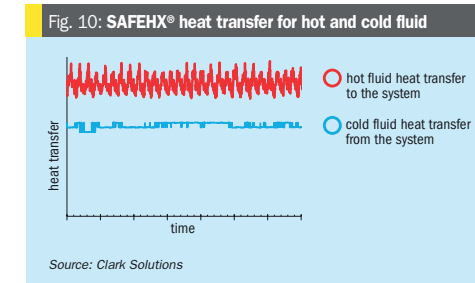

Fig. 10: SAFEHX heat transfer for hot and cold fluid

CONTENTS

What's in issue 394

COVER FEATURE 1

Sulphur market update

COVER FEATURE 2

India's acid demand

COVER FEATURE 3

SRU revamping

COVER FEATURE 4

Wet gas cleaning

SULPHUR
ISSUE 394
MAY-JUNE 2021

BCInsight

Southbank House, Black Prince Road
London SE1 7SJ, England
Tel: +44 (0)20 7793 2567
Fax: +44 (0)20 7793 2577
Web: www.bcinsight.com
www.bcinsightsearch.com

Fig. 11: 304L stainless steel isocorrosion lines

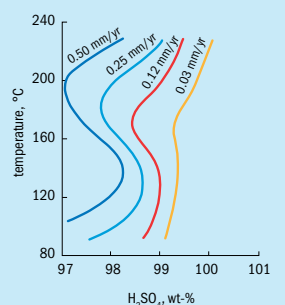

Source: Clark Solutions

Fig. 12: 310S stainless steel isocorrosion lines

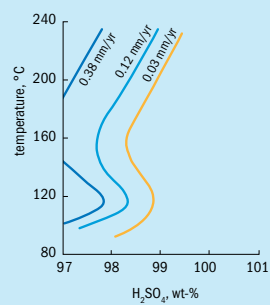

Source: Clark Solutions

Table 2: SAFEHX® preliminary tests results

Fluid Pair	Conditions	Results
Cold side heat transfer coefficient	3 hours duration Inert fluid condensation to warm cold water	500 to 1,000 W/(m ² -K)
Hot side heat transfer coefficient	3 hours duration Inert fluid evaporation to cool hot water	500 to 1,000 W/(m ² -K)
Overall heat transfer coefficient	3 hours duration Continuous evaporation and condensation of buffer fluid	250 to 500 W/(m ² -K)

Source: Clark Solutions

pressure. Within wide systems, retrieving specialty fluids may not be possible.

SAFEHX® can detect variations on the shell side to inform if any leak occurs, as unlikely as leaks may be considering inert fluid properties. In these events, the closed buffer circuit can then be carefully drained to retrieve any process fluids introduced inside the shell.

Risks of contamination are even lower, as this would require that a leak occur in both submerged and emerged tubes and would also require an existing pressure gradient from one to the other tube. Contaminating cold fluid with hot fluid, and vice-versa, is nearly impossible.

Materials of construction

Materials of construction for SAFEHX® pipes depends on the hot and cold fluids within the tubes, but a carbon steel shell can always be employed as the buffer fluid is inert. The SAFEHX® approach, due to its operational conditions, enables the shell

to be constructed of common carbon steel alloys as the shell is only in contact with the inert fluid.

Despite using a carbon steel shell, the piping must be compatible with the process fluids. To be able to supply this technology for a wide variety of process, Clark Solutions can manufacture the SAFEHX® piping with almost any material.

Strong acid at normal absorption temperatures can be handled with a myriad of materials that proved efficient for such conditions. High silicon austenitic stainless steels like CSX™ and similar (CSX™ is the trademark for Clark Solutions high silicon stainless steel), 310 Stainless Steel, Alloy 20, and others have all proven resistant to different ranges of acid conditions.

Water tubes can be carbon steel or, where needed, stainless steel.

While proper material selection is very important to minimise failure risks, corrosion is a matter of time and operational control, and leaks eventually happen. In

the case of a leakage event, sensors can identify any liquid entering the shell side to properly drain in a timely manner, if necessary. Even when corrosive liquids enter the shell side, the absence of oxygen inside will hinder oxidation and corrosion. It is possible to perceive that safety was a major issue when developing SAFEHX®. SAFEHX® systems can be constructed in the materials suitable to any operating conditions.

SAFEHX® performance

After processing sensors measurements, it was possible to verify that the heat exchanger, operating with a 1,000-1,200 litres/hour volumetric flowrate in the hot-water loop, was capable of transferring about 4 kW. The temperature and heat transfer results are shown in Figs 9 and 10. The cold-water loop flowrate of 1,000-1,200 litres/hour retrieved roughly 3 kW of heat from the exchanger. The difference between those two heat rates came from the shell convection heat loss, due to the absence of insulation. The visible oscillations for the hot loop were caused by the on-off control of the hot water loop temperature. The overall heat transfer coefficients estimated from the prototype measured parameters were close to the numerical models and are shown in Table 2. Further prototype improvements and different sets of operation conditions were already issued and, just by installing shell insulation, an increase of at least 15% is expected on the overall heat transfer coefficient. As a starting point of the technology, there is already a prototype with heat transfer performance for liquids compatible with commercial products and with all the safety and process control improvements already mentioned.

Conclusion

SAFEHX® is a new, breakthrough approach, that adds a substantial safety feature to existing or new sulphuric acid plants. The prototype achieved its original objective of safe heat transfer in a compact device as originally intended. But it also benefits heat transfer operations with high fouling rates, operations where cold liquid temperature control is important, and cases where process liquid loss is costly. All of this can be achieved with cost-effective equipment. The prototype is in an advanced stage and a commercial version of the product should be available in 2021.

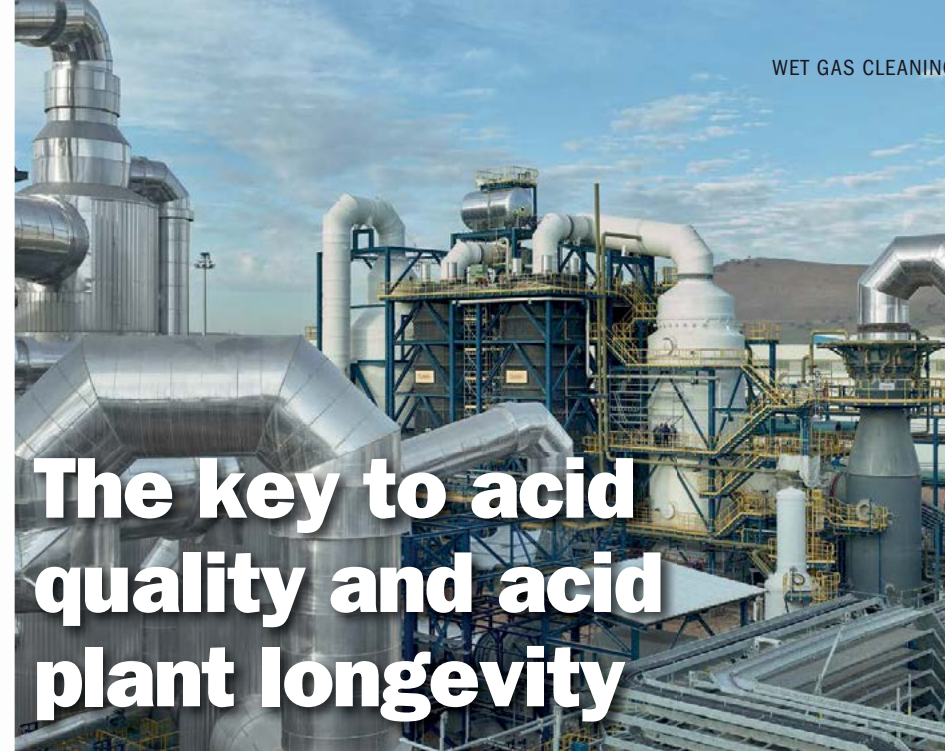

The key to acid quality and acid plant longevity

With declining ore grade feed to a metallurgical smelting process comes an increase in impurity load in the gas cleaning/acid process chain. **K. Hasselwander, L. Skilling and C. Bartlett** of Metso Outotec discuss a range of process solutions and how to maintain high productivity while keeping costs in check.

In order to enable the continuous production of sulphuric acid, the gas must be thoroughly cleaned. All inorganic matter, which could contaminate the acid or have an impact on plant operation by decreasing the plant availability, must be removed from the gas.

A wet gas cleaning system design must take into account the dynamic conditions of the operation of the upstream installations. Gas treatment systems for metallurgical furnaces releasing SO₂ containing gases usually consist of a gas cooling and hot gas dedusting system followed by a wet gas cleaning system. This article will concentrate on the wet gas cleaning train.

Gas cleaning can often be overlooked, with no second thought or concern on its operation or condition. However, it is integral to overall plant efficiency, and it is a big mistake to think otherwise. To ensure that your plant is in the best condition

for the future, you need to keep your gas cleaning facility in peak condition. Though different alternatives may seem feasible in the short term, a plant needs reliable and productive equipment to maintain operation in the long run. Metso Outotec has the capability to deliver high quality, tailored solutions and ensure flawless plant operation.

“When making statements on increasing impurity loads, it is important to keep in mind the underlying causes for the change,” says Leif Skilling – Director, Gas Cleaning Product Group at Metso Outotec. “These will no doubt have immense future implications for our industry and it’s time we start seriously considering them.”

Table 1 illustrates the degradation in ore quality that has taken place since the 1900s.

Decreasing quality leads to increasing amounts of unpleasant impurities, such as arsenic, hydrogen chloride, hydrogen fluoride, mercury, selenium and more. Many of these impurities have a negative and direct effect on the gas cleaning plant, as well as the sulphuric acid plant.

Table 1: Degradation in ore quality

Metal	1880-1900	1950-1960	Today
Gold, g/t	22-23	5	1.94
Silver, g/t	1,175	154	98.4
Copper, %	7.60	1.35	0.95
Lead, %	14.42	10.41	3.50
Zinc, %	15.68	10.42	7.77

Source: “Peak Silver and Mining by a Falling EROI”, *Commodities/Gold & Silver*, Steve St Angelo, Nov 04, 2009, <http://www.marketoracle.co.uk/Article14756.html>.

CONTENTS

What’s in issue 394

COVER FEATURE 1

Sulphur market update

COVER FEATURE 2

India’s acid demand

COVER FEATURE 3

SRU revamping

COVER FEATURE 4

Wet gas cleaning

SULPHUR
ISSUE 394
MAY-JUNE 2021

BCInsight

Southbank House, Black Prince Road
London SE1 7SJ, England
Tel: +44 (0)20 7793 2567
Fax: +44 (0)20 7793 2577
Web: www.bcinsight.com
www.bcinsightsearch.com

Table 1: Consequences of various deleterious elements on acid plant operation

Consequences for acid plant operations

Arsenic (As ₂ O ₃)	<ul style="list-style-type: none"> Below 600°C, saturation of catalyst and reduced catalyst activity Above 600°C, volatile compound V₂O₅*As₂O₃ can be formed and some long-term loss of activity due to permanent vanadium losses
Selenium	<ul style="list-style-type: none"> Reduces catalyst activity Harmful effect only at temperatures below 400°C; initial activity is restored after heating
Dust	<ul style="list-style-type: none"> Accumulates in the catalyst bed and on candle filters Accumulations on the catalyst increases pressure drop and reduces throughput
Heavy Metals (Pb, Hg)	<ul style="list-style-type: none"> Deposits result in significant catalyst activity loss
Fluorides (F)	<ul style="list-style-type: none"> Reacts with the catalyst silica support, forming volatile SiF₄, and deposition of silica gel on the catalyst surface has been observed Mixture of HF and H₂SO₄ is a strong oxidising agent
Chlorides (Cl)	<ul style="list-style-type: none"> At high concentrations, VOCl₃ is formed leading to vanadium loss Significant attack/corrosion of steel equipment of the SAP

Source: Metso Outotec

Fig. 1: Wet gas cleaning system

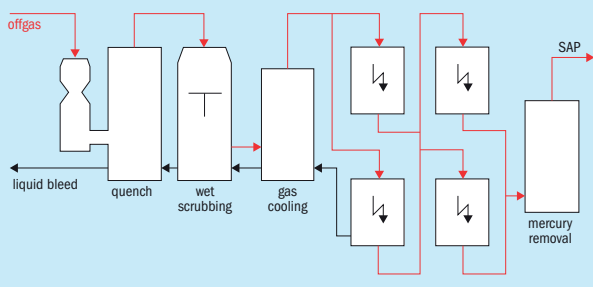

Source: Metso Outotec

If you increase the amount of impurities to a plant, it is inevitable that it will also directly affect the overall efficiency of the gas cleaning plant, the quality of the acid produced, and the lifetime of the whole plant and process train.

A sulphuric acid plant today must produce high quality acid – this is essential. These higher impurity levels are not only affecting the results and quality of the acid but over time, the equipment as well. Any neglect in facing these issues immediately, or without the proper expertise and know-how, will lead to irreversible damage and a loss of productivity.

The task of the gas cleaning system is to ensure the reliable operation of the plant, producing sulphuric acid at a specified concentration (e.g. 98.5% concentration) and purity. Acid contaminants including heavy metals such as arsenic, lead, antimony, selenium, and mercury must remain within permitted levels as the cleaned gas is released to the atmosphere. Acid mist removal is also necessary to prevent corrosion within the acid plant itself, while fluoride removal protects the candle filters in the absorbers from damage. The dust removal upstream of the plant must be employed to avoid

clogging of tower packing and mist eliminators. Table 2 lists consequences of various deleterious elements on acid plant operation.

Wet gas cleaning system

A wet gas cleaning system for a metallurgical sulphuric acid plant consists of a series of unit operations (see Fig. 1).

The unit operations (in order of priority) consists of the following:

- Quench cooler:** This operation unit is always installed. Depending on the requirements, the quencher can also be designed for scrubbing or dust elimination. The gas is fully saturated with water at the quencher outlet.
- Scrubber:** A scrubber is designed for removing dust from the gas flow. The liquid injected into the scrubber captures the dust particles. Scrubbing efficiency can be improved with an increased energy input into the system. Depending on the dust removal efficiency required, the gas flow characteristics and the dust type, scrubbers may have different designs.
- Gas cooler, water vapour condenser:** The amount of water vapour in the gas is reduced to the maximum amount allowed for the sulphuric acid plant water balance. The allowable amount depends on the SO₂ content of the gas. When the gas is cooled, the water vapour is condensed.
- Two-stage wet ESPs:** Fine dust particles and aerosols are removed from the gas in wet electrostatic precipitators (WESPs).
- Subsequent stages:** Elements or compounds which cannot be sufficiently removed from the gas by applying the above unit operations are treated in additional stages. This is true for both gaseous metallic mercury and for halides.

Quench coolers and scrubbers

Many technical solutions have been developed for quenchers and scrubbers. In the quencher, independent of the apparatus design, the gas is cooled when the water evaporates. The heat from the incoming gas with a temperature exceeding 300°C is used for water evaporation, which is then sprayed into the quencher. The sensitive heat of the gas is converted into water vapour (latent heat). The energy (enthalpy) from the incoming gas flow (high temperature and low water

vapour content) is the same as the energy (enthalpy) from the outgoing gas flow (low temperature and high water vapour content). This type of cooling can be considered an adiabatic process, i.e. a process operated without an energy exchange with the environment. The gas is usually water saturated at the quencher/scrubber exit. If the temperature is lowered, water vapour will condense.

The quencher normally has a temperature and acid-resistant brick lining. If the downstream installations are sensitive to temperatures exceeding 80°C, the quencher needs to be equipped with two fully independent liquid circuits. Each circuit must have its own pump, pipes and nozzles. This 100% redundancy ensures safe operation in the event of a pump or nozzle failure. In addition, Metso Outotec recommends installing an emergency spray system that will start in case of temperature excess and power failure.

A quencher can also be designed with high removal efficiency for dust. Alternatively, a separate scrubber is installed downstream of the quencher. In cases where substances condensed in the quencher cooler are to be removed from the gas, a separate scrubber downstream of the quencher (humidification tower) is recommended. This is the case for arsenic released from copper smelters. Scrubber and quencher design, as well as selection, depend on process requirements such as gas flow rate, dust load, presence of condensable matter in the gas, efficiency required, dust type and particle size distribution, as well as the amount of solids and dissolved matter in the scrubbing liquid.

An important scrubber feature is the careful selection of nozzles. Not only should they be designed to withstand possible temperature excess, but also for the abrasion, which results from particles suspended in the scrubbing liquid. Some scrubbers have special design features for handling fluctuating gas flow rates. This applies for scrubbers with an adjustable throat. An adjustment can be made to the cross-section area of the scrubbing zone, which affects pressure drop and consequently scrubbing efficiency. During operating conditions which require only a reduced scrubbing efficiency, the pressure drop can be decreased, reducing the energy consumption.

The most critical area in a quencher is the transition zone from hot and dry to wet and acidic. Both areas require different types

of mortar and bricks. To ensure that there is a clearly defined transition zone, Metso Outotec has developed the "Otovent", a venturi-type quencher equipped with a ring zone, which allows for a clearly defined wet-dry transition zone (Fig. 2).

Usually, the excess liquid from the wet gas cleaning system is discharged from the quencher circuit as weak acid, which is neutralised in an effluent treatment system. The gas flows through a strong electrostatic field, which is made from grounded collection electrodes and negatively charged discharged electrodes where an "electrical corona" is created. The corona releases electrons and electrically charged gas molecules, mainly oxygen. When these ions come into contact with aerosols and particles, they are also charged. Guided by the electrostatic field, the negatively charged particles migrate to the collection electrodes where they are discharged and form a liquid film which flows downward, and drips into the bottom of the casing where it is then drained.

Gas cooling/water vapour condensing systems

While passing through the quencher/scrubber, the SO₂ gas is saturated with water vapour. In the acid plant drying tower, the water vapour is completely removed due to the absorption in the circulated sulphuric acid. When forming sulphuric acid, the following equation applies:

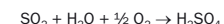

For a single molecule of SO₂, one molecule of water vapour can be in the SO₂ gas. Design criteria for the gas cooling stage includes the temperature at the inlet based on the enthalpy of the incoming gas and the gas SO₂ content and consequently, water vapour content going to the acid plant, including a certain safety margin. The inlet and outlet pressure are also considered. The system must be designed to take into account the dust and aerosol load, as well as the halides and dissolved matter in the cooling liquid.

Direct cooling of the gas in gas/liquid heat exchangers made of acid-resistant materials such as plastic and lead can bring down the gas temperature very close to the cooling water temperature. However, these coolers, where the gas usually flows through the tubes and the cooling water is guided around the tube bundles, may also be subject to build-up and due to their mechanical design, are very difficult to clean. The most popular gas cooler/condenser model is the packed gas-cooling tower, where liquid cooled in plate heat exchangers is circulated over a packing made of filling bodies. This "indirect" gas cooler/condenser can be designed to minimise build-up in both the packing and cooling liquid circuit.

Wet electrostatic precipitators

Scrubber efficiency drops significantly for particles smaller than five microns. These small particles are removed in wet electrostatic precipitators (WESPs). Aerosols and dust are eliminated in WESPs from the gas using high tension. The gas flows through a strong electrostatic field, which is made from grounded collection electrodes and negatively charged discharged electrodes where an "electrical corona" is created. The corona releases electrons and electrically charged gas molecules, mainly oxygen. When these ions come into contact with aerosols and particles, they are also charged. Guided by the electrostatic field, the negatively charged particles migrate to the collection electrodes where they are discharged and form a liquid film which flows downward, and drips into the bottom of the casing where it is then drained.

Design parameters for WESPs are the actual gas flow and the efficiency required for dust and aerosol elimination. Operating temperature and operating pressure are also needed for mechanical design. The gas composition and trace gases also need to be determined. Metso Outotec recommends a two-stage system to ensure a consistently reliable operation of this important component of the wet gas cleaning system.

Modern WESPs are designed with round or hexagonal collection tubes made of plastic and arranged in bundles. The discharge electrodes are mounted in the centre of the tubes. Various types and materials are used for WESPs. The casings are manufactured of fibre-reinforced plastic (FRP) or coated steel. Alternatively, the collection electrodes can be made of stainless steel or other corrosion-proof materials.

Fig. 3 shows a wet electrostatic precipitator based on the Metso Outotec design (Editube). The gas flow is usually oriented downwards.

The insulators, which support the discharge electrode system, are an important component of every WESP. Due to the moist and acidic environment inside the WESP, any condensation on the insulators must be prevented. To prevent condensation, two techniques can be implemented: electrical heating and air flushing. Insulator heating is preferable in the case where the SO₂ gas must not be diluted. In the event that a WESP is operated under over pressure or

WET GAS CLEANING



PHOTO: METSO OUTOTEC

Fig. 2: Metso Outotec's Otovent venturi scrubber



PHOTO: METSO OUTOTEC

Fig. 3: Metso Outotec's Editube WESPs

Fig. 4: Metso Outotec's B-N mercury removal process

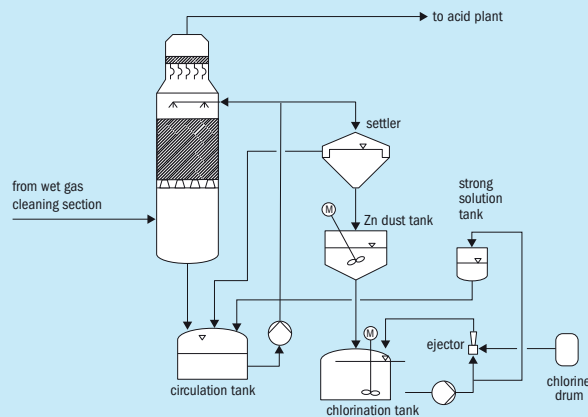

Source: Metso Outotec

fluctuation conditions, air flushing may be a better solution.

Wet ESPs are usually equipped with a flushing system for cleaning of the internals (discharge and collection electrodes). Cleaning usually takes several minutes. During this time, the high tension is switched off. The decision whether the vessel should be bypassed has to be made based on the process design of the installation.

Mercury removal systems

In cases where a significant amount of mercury is present in the gas, a separate mercury removal system is required. Although a large portion of the metallic mercury is removed in the wet gas cleaning system by reactions between the mercury and other ions such as selenium and chlorides, there may still be sufficient gaseous metallic mercury to contaminate the product acid.

A number of different processes have been developed for mercury elimination. The most popular system used for the elimination of metallic mercury is the Boliden Norzink Process (calomel process) as shown in Fig. 4.

The principle of the calomel process (Boliden-Norzink mercury removal process) is that gaseous metallic mercury present in the SO₂ gas reacts with mercury chloride dissolved in a reaction liquid and forms a solid mercury chloride compound, calomel.

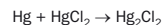

Where: Hg is gaseous; HgCl₂ is in dissolved complex form; and Hg₂Cl₂ (calomel) precipitates as solids.

Calomel is removed from the reaction liquid circuit by liquid/solid separation in a settling tank and stored in a tank arranged beneath the settler. Prior to discharging the excess liquid, the dissolved mercury chloride is also precipitated by adding zinc dust. The reaction liquid containing the dissolved mercury chloride is prepared batch-wise by chlorination of calomel with chlorine gas. This concentrated "strong solution" is then stored in a storage tank and added to the reaction circuit where it is diluted to the concentration required for the operation of the system.

In addition to the standard process, a number of other methods have been developed in a variety of smelters to remove mercury from the SO₂ gas or from the produced acid itself. Generally, every process

WET GAS CLEANING

has been designed to achieve sulphuric acid with a mercury content of less than 1 ppm. To achieve mercury contents of less than 0.1 ppm, some copper smelters apply additional mercury removal stages, which have been designed as adsorption processes. These are usually arranged downstream of a calomel process. The mercury-containing SO₂ gas passes through an absorber that has several layers of an absorption agent. The mercury reacts with the absorption agent to form an insoluble mercury compound. Selenium is one of the absorption agents that may be used for mercury absorption. Metso Outotec offers a process which utilises a scrubber stage with a selenium filter for achieving mercury contents of less than 0.1 ppm.

Halide removal systems

The major portion of halides has already been removed in the scrubber and packed gas cooling tower by absorption in the circulated liquid. If high liquid temperatures and high concentrations of absorbed matter occur, there may be significant amounts of gaseous halides which can reach the acid plant. This may result in damage to the candle filters, due to fluoride attack.

To reduce the concentration of dissolved fluorides, sodium-silicate can be added to the liquid circulated in the packed gas cooling tower. In the event of very high halide content, a separate fluorine removal tower needs to be installed. Fluorine removal towers are designed as vessels equipped with ceramic filling bodies. The gas flows downwards co-current with liquid circulated in the tower. The filling bodies are eaten up by the fluorides and need to be occasionally replaced. To minimise the acid load and carry-over into the acid plant, the fluorine removal tower is often installed between the two stages of WESPs.

Wet gas cleaning system health check/audit

If problems are observed in a scrubber, it is often useful to touch with the palm of your hand the individual pipes supplying the nozzles with liquid. A human palm is normally very sensitive to temperature. If one of the pipes appears to have a significantly different temperature, the respective nozzle may be lost or blocked. Nozzle loss can be considered more critical than the blockage of a pipe.

The trend of the electrical values is a good indication of WESP operation. If the second stage is in operation with little flash-over (maximum 3 to 5 flash-overs per minute) and the specific electrical current exceeds 0.3 milliampere (mA) per square metre of the collection area, the functioning of the WESP can be considered good. If this is not the case, Metso Outotec recommends a more detailed investigation to determine the reason for the deviation.

For other stages involved in gas cleaning systems, such as mercury removal or fluoride removal, Metso Outotec recommends regular sampling and analysis of the circulated liquid. A good estimate of the overall operation of a wet gas cleaning system with WESP is a lamp section (a 40 W bulb with a sight glass at distance of 5 m). If no clouds are visible, the sulphuric acid mist content is below 25 mg/Nm³. By installing a simple instrument for measuring the opacity, the mist content and the overall performance of the gas cleaning system can be viewed on the control monitor in the acid plant control room.

Last but not least, Metso Outotec recommends that plants have a regular expert assessment of the process system every 12 to 18 months.



99.9+%

sulphur recovery efficiency

we make it real
with our sulphur technology

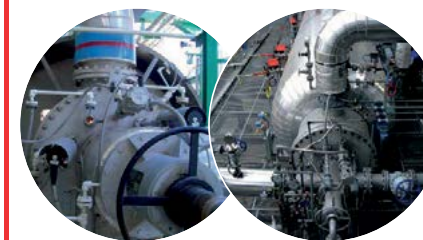

we can develop your project
from its inception to early production

- Claus unit and tail gas treatment (HCR)
- Oxygen enriched air Claus
- Advanced ammonia Claus
- Sulphur degassing
- Thermal and catalytic oxidisers
- Major Claus equipment
(main burners, thermal reactors, WHB, condensers)

Siirtec Nigi
Engineering & Contracting Solutions

www.siirtecnigi.com - marketing@siirtecnigi.com

www.sulphurmagazine.com

CONTENTS

What's in issue 394

COVER FEATURE 1

Sulphur market update

COVER FEATURE 2

India's acid demand

COVER FEATURE 3

SRU revamping

COVER FEATURE 4

Wet gas cleaning

SULPHUR
ISSUE 394
MAY-JUNE 2021

BCInsight

Southbank House, Black Prince Road
London SE1 7SJ, England
Tel: +44 (0)20 7793 2567
Fax: +44 (0)20 7793 2577
Web: www.bcinsight.com
www.bcinsightsearch.com

SRU revamping for emissions compliance and capacity increase

With the sulphur content of crude oil and natural gas on the increase and with the ever-tightening sulphur content in fuels, refiners and gas processors will require additional sulphur recovery capacity. At the same time, environmental regulatory agencies of many countries continue to promulgate more stringent standards for sulphur emissions from oil, gas and chemical processing facilities. Rameshni & Associates Technology and Engineering discusses options for compliance with new regulations on emissions regarding IMO 2020 compliance and report on the results and evaluation of three case studies. Worley Comprimo reports on the revamp of a sulphur complex built in the late 1980s at a refinery in East Asia with the aim to increase the capacity, improve the availability and reliability and make the unit environmental compliant.

RAMESHNI & ASSOCIATES TECHNOLOGY AND ENGINEERING (RATE USA)

IMO 2020 compliance and SRU revamping

M. Rameshni and S. Santo

New regulations, such as IMO 2020, mandate a maximum sulphur content of 0.5% in marine fuels globally. The driver of this change is the need to reduce the air pollution created in the shipping industry by reducing the sulphur content of the fuels that ships use.

This will bring marine air pollution control in line with power plants and refineries, where continuous emissions monitoring systems (CEMS) monitoring NO_x and SO₂ emissions have been used for decades.

The first option to reduce sulphur emissions from ship exhausts is to burn fuel with a low sulphur content. This solution mirrors the land-based transportation sector where low sulphur petrol and diesel are the norm. Refineries are taking a variety of approaches to meet the changed demand for bunker fuels. Some will invest to increase the amount of low sulphur heavy fuel oil capacity and delayed-coker construction projects are underway in several locations.

The second option for marine emissions reduction is for ships to use conventional high sulphur fuel oil and an exhaust gas cleaning system (EGCS), similar to those used in land-based systems where power plants, for example, use scrubbers fed with lime to reduce sulphur emissions. With the demand for low sulphur fuels expected to increase, due to the IMO 2020 regulations, the price for these fuels is also likely to rise. Therefore, investment in an EGCS which enables the use of lower cost higher sulphur fuels may be highly attractive for shipping operators.

In general, EGCSs use either seawater in an open loop system or rely on internal recirculation of fresh water mixed with caustic soda or other alkaline chemicals as the scrubbing medium in a closed loop system. Some ports have expressed concerns about the discharge of open loop scrubber wastewater, so the closed loop versions have an important role to play,

despite their additional operating cost. However, some scrubber processes can easily switch between the open or closed loop operation modes. This is particularly important in brackish waters such as river estuaries and means that the vessel can sail anywhere without over-dimensioning the scrubber system. Some scrubbers also incorporate a system for treating closed loop wash water known as bleed-off to comply with strict IMO requirements and can be discharged overboard.

A third option is that some refineries are adding a delayed coker to convert heavy, higher-sulphur residual oils into transportation fuels such as marine gas oil and diesel. The delayed coker follows other units at the site, such as the cogeneration unit and the diesel hydrotreater. Whatever the refinery does with regard to additional process units and configuration changes, one thing is for sure: increased sulphur removal will require increased quantities of hydrogen. Hydrogen reacts with sulphur to

Fig. 1: Simplified refinery scheme showing the hydrotreater and sulphur recovery unit

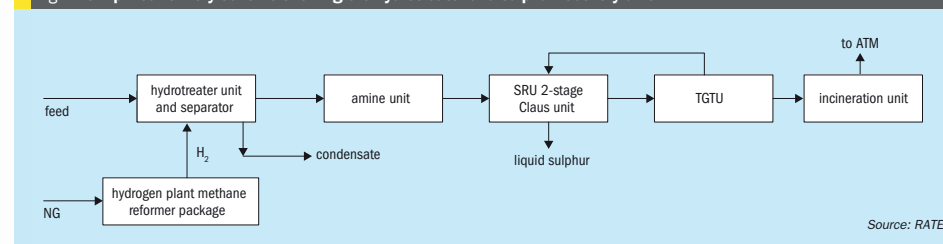
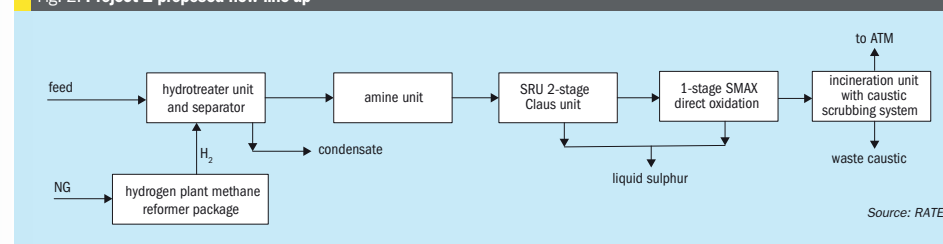

Fig. 2: Project 2 proposed new line-up



form hydrogen sulphide, which can either be burned in the refinery or converted to elemental sulphur for the chemicals sector. As a result, the existing sulphur recovery facilities require additional capacity to comply with the overall SO₂ emission levels and environmental regulations.

Fig. 1 represents a typical simplified refinery scheme showing the hydrotreater and the sulphur recovery units.

Crude oil-derived fuels contain aromatic compounds such as thiophene and its derivatives, which are forms of sulphur that are difficult to remove. Hydrodesulphurisation (HDS) is a catalytic chemical process used to remove sulphur from refined petroleum products. Typical catalysts used in HDS include sulphided Ni-Mo and Co-Mo active components supported on alumina. Traditional HDS processes create H₂S gas that needs to be scrubbed downstream.

Diesel hydrotreating (DHT) or catalytic hydrogen treating is mainly used to reduce undesirable species from straight-run diesel fraction by selectively reacting these species with hydrogen in a reactor at elevated temperatures and at moderate pressures.

RATE has studied three different projects related to this topic as described in the following sections.

Project 1

In project 1, a shipping terminal located in the USA, where environmental regulations are very tight, would like to reduce the sulphur content of the fuels it supplies to ships. Since the terminal does not have any processing units, to supply clean fuel would require high investment costs to install a large hydrotreater and a large sulphur block.

RATE's proposal included the installation of a new hydrotreater, followed by an amine unit and the sulphur recovery unit plus all the utilities and required catalysts and chemicals. The new SRU/TGU would have a capacity of about 250 t/d. The required hydrotreater was a large unit. By the time the study was completed the capital cost for this grass root facility was significantly high. The conventional tail gas unit was therefore changed to produce ammonium thiosulphate solution, a product that can be sold and is profitable. This had the benefit of reducing the capital cost and providing a faster return on investment. The final decision has not yet been made.

Project 2

In project 2, an oil and gas operator trading refinery liquid products has a terminal and storage tank farm located in the

Middle East. The facility has partial capability to process crude, and would like to supply clean fuel to its customers. Occasionally, liquid products are received that contain high levels of sulphur contamination, but nowadays many customers are looking for low sulphur products. The aim is to procure and install a desulphurisation unit with a processing capacity of 100,000 tonnes per month at the facility in order to reduce sulphur contamination from various refinery products such as diesel, fuel oil and gasoline, to meet the new regulations.

Diesel with a sulphur content of 10,000 ppm including mercaptans and fuel oil with 35,000 ppm sulphur content including mercaptans were evaluated. The product will meet less than 50 ppm of sulphur. The maximum amount of sulphur to be removed and processed is about 30 t/d.

Fig. 2 shows a block diagram of what was proposed in the study.

Since the sulphur recovery unit is relatively small, and in order to minimise the investment, RATE proposed SMAX direct oxidation technology plus a caustic scrubbing system after the incineration. The SO₂ specification from the incinerator stack is less than 10 ppmv. The caustic will be neutralised as part of the design, so there will be no issues with a spent caustic waste stream.

CONTENTS

What's in issue 394

COVER FEATURE 1

Sulphur market update

COVER FEATURE 2

India's acid demand

COVER FEATURE 3

SRU revamping

COVER FEATURE 4

Wet gas cleaning

SULPHUR
ISSUE 394
MAY-JUNE 2021

BCInsight

Southbank House, Black Prince Road
London SE1 7SJ, England
Tel: +44 (0)20 7793 2567
Fax: +44 (0)20 7793 2577
Web: www.bcinsight.com
www.bcinsightsearch.com

In this study, the facility has the utilities required for the new units therefore, the total investment relative to the capacity is much lower than in project 1. The study is currently under review and consideration for the path moving forward.

As described in the introduction, in most cases the sulphur is removed from the fuel to meet environmental regulations, either by using a caustic scrubbing system at the port, or by using sea-water scrubbing when the ship is moving in the water.

Project 3

In project 3 a study was conducted for a refinery in Europe to convert heavy, higher-sulphur residual oils into transportation fuels such as marine gas oil and diesel. The facility has a hydrotreater and a sulphur recovery unit in operation, but depending on the refinery production capacity, the required size of these units will be different. The recovery of additional sulphur requires modifications to the existing units to comply with environmental regulations, including the hydrotreater, coker unit, amine unit, sulphur recovery and tail gas treating units.

Hydrotreater modifications

Starting with the hydrotreaters, the hydrotreater catalysts have been improved to take more sulphur compounds, sometimes hydrolysis reactors are added. In addition, as part of the revamp, additional sections can be added to the catalyst bed, or the configuration can be changed by adding integrated back-staged hydrocracking to the hydrotreating unit, or by using a two-stage hydrocracking configuration in the hydrotreating unit. A two-stage hydrocracking unit flow scheme with integration of hydroisomerisation catalyst to the hydrotreating unit will take care of the necessary modifications and are proposed by hydrotreater licensors.

Sulphur block evaluation and modifications

Where more H₂S is to be processed in the amine unit, the amine solvent, the absorber and regeneration internals, and the reboiler duty should be evaluated. It may be necessary to use a higher amine concentration, change to a more selective amine solvent, upgrade the tower internals, or increase the reboiler duty to strip

the additional H₂S and send it to the sulphur recovery unit.

Processing more H₂S also requires additional capacity in the SRU. IMO 2020 mandates a maximum sulphur content of 0.5% for fuel in most cases this translates into additional sulphur capacity ranging from 20% to 70% which can be achieved by using low-level to medium-level oxygen enrichment. If even more capacity is required then high-level oxygen enrichment should be applied.

In terms of modifications, using low-level to medium-level of oxygen enrichment requires a control system on the oxygen line, and in most cases a new burner to handle the oxygen and upgrading of the refractory. The downstream equipment in the SRU should also be evaluated but in most cases no changes would be required.

SRU burner and reaction furnace

Low-level oxygen enrichment is accomplished by injecting pure oxygen or oxygen-rich air into the combustion air; i.e., oxygen is premixed with combustion air upstream of the burner. No burner modification is required in the existing SRU, other than providing the tie-in point for oxygen injection in the combustion air line. For medium-level or high-level oxygen enrichment with rich H₂S, the burner designed for air-only operation may not be able to withstand the higher combustion temperature. In any case, direct injection of oxygen through separate nozzles from combustion air is recommended; hence, special burners designed for direct oxygen injection should be installed.

The existing reaction furnace should be evaluated for low-level oxygen enrichment, but no changes are normally required. For medium- or high-level of oxygen enrichment, several factors should be considered.

If the sulphur plant to be modified has a feed gas with high H₂S content, a new reaction furnace is required as a first combustion chamber; the existing reaction furnace can be used as a second combustion chamber, provided that the existing reaction furnace is well maintained and the refractory lining is adequate. Oxygen enrichment has the following impacts on the burner and reaction furnace design:

- The existing refractory lining should be evaluated for the higher combustion temperature. In many cases, the refractory system will need to be upgraded to accommodate the higher operating temperature.

The maximum operating temperature is limited by the refractory limits, about 2,700°F/1,480°C to 2,900°F/1,590°C (for short time excursions).

- If the burner needs to be replaced the size of the existing nozzle should be evaluated for the new burner location.
- If the reaction furnace contains a choke ring or checker wall, it should be evaluated for flame impingement with the new burner flame characteristics.
- A higher partial pressure of elemental sulphur, SO₂ and H₂O vapour, leads to higher sulphur dew points.
- Producing more hydrogen, which is beneficial in tail gas treating as a reducing agent, can also be used as a fuel in the incinerator.
- Increase the efficiency of downstream Claus catalytic reactors.
- Better destruction of ammonia, HCN, heavy hydrocarbons and BTEX, or any contaminants, requires a higher combustion temperature.
- The gas volumetric is about the same, no changes in residence time.
- An oxygen line should be provided to the unit; a burner management system ESD system, and oxygen demand controls should be added or modified for oxygen supply.
- Purging requirements will be different and should be considered.
- Pilot/ignition requirement should be evaluated.
- Acid gas piping pressure drop and instrumentation should be evaluated to maintain the pressure profile throughout the unit.
- The plot plan should be evaluated if the burner is replaced.
- The location for the flame scanners should be evaluated with the burner replacement for the replacement or relocation. RATE recommends IRIS S-550 type flame scanners for their robustness in sulphur plants and since they are not affected by pipe x-raying, heat and radiation on the site.
- The flow meters and control valves on the acid gas lines should be evaluated for a higher flow rate and turndown issues.
- The existing refractory should be evaluated for a higher combustion temperature in the reducing atmosphere. The principle of using double combustion for processing H₂S-rich acid gas is that 90% alumina refractory with silica, in a reducing atmosphere, has a maximum

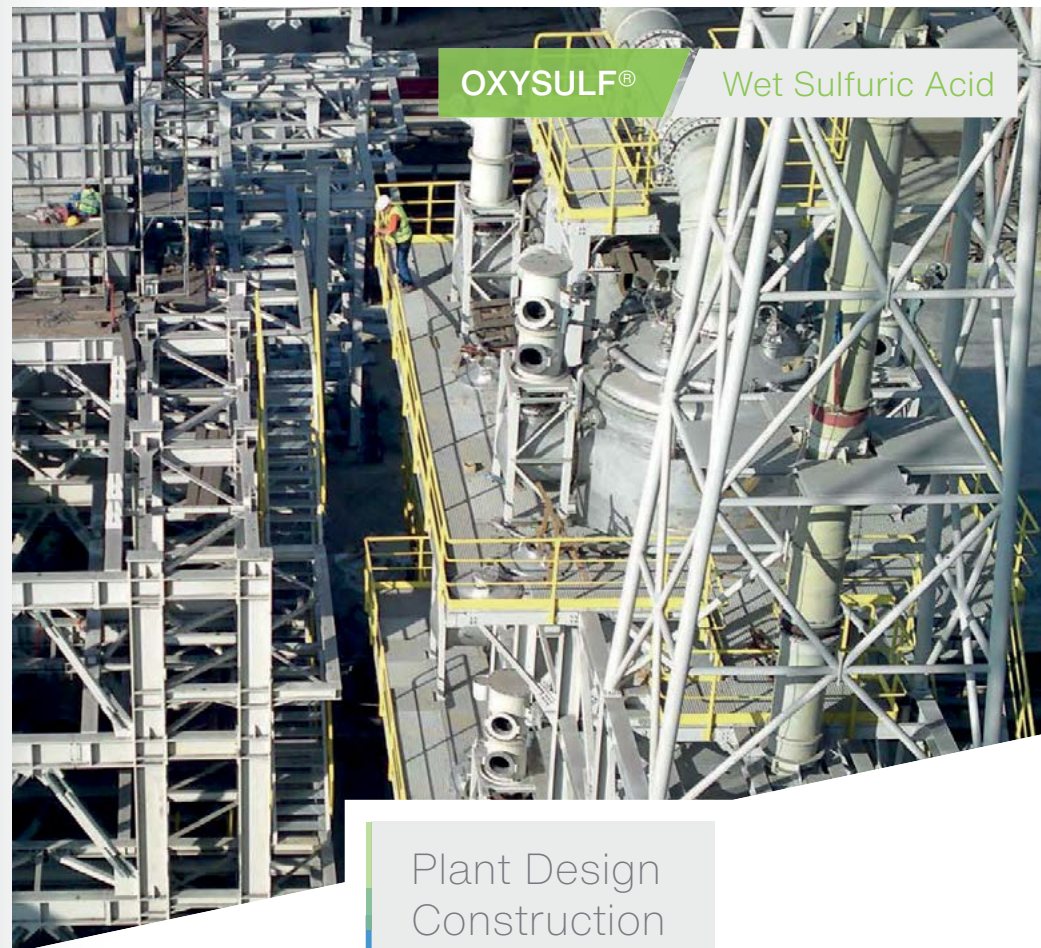

Plant Design
Construction
Aftersales

- + Sulfuric Acid recovery from off gas
- + Sour & Acid gas treatment
- + Smelter gas treatment
- + Spent Acid regeneration

kvt.technology 
www.kvt.technology

CONTENTS

What's in issue 394

COVER FEATURE 1

Sulphur market update

COVER FEATURE 2

India's acid demand

COVER FEATURE 3

SRU revamping

COVER FEATURE 4

Wet gas cleaning

SULPHUR
ISSUE 394
MAY-JUNE 2021

BCInsight

Southbank House, Black Prince Road
London SE1 7SJ, England
Tel: +44 (0)20 7793 2567
Fax: +44 (0)20 7793 2577
Web: www.bcinsight.com
www.bcinsightsearch.com

temperature limitation, and using 94% alumina refractory with magnesium is very sensitive to thermal shock in a reducing atmosphere and may not be very cost effective, but it will handle the higher combustion temperature. The melting point of 90% alumina with silica and 94% alumina with magnesium is about 3,400°F and 3,500°F respectively. However, the ferrules should be evaluated for this combination.

Waste heat boiler and steam drum

Hot gases leaving the reaction furnace are cooled in the waste heat boiler by generating steam. The existing waste heat boiler and steam drum should be evaluated, for low level of oxygen, no changes or concern is required. For a medium or high level of oxygen with rich H₂S content, the existing waste heater could be used as a second pass waste heat boiler and a new waste heat boiler should be added as a first pass waste heat boiler.

For lean H₂S acid gas and high-level oxygen enrichment, single combustion is adequate, therefore there is no need for an additional waste heat boiler, if the existing waste heat boiler is well designed and well maintained.

Oxygen enrichment has the following impacts on the waste heat boiler design:

- Higher operating temperature, resulting in higher heat duty, which requires more cooling.
- More sulphur vapour from the reaction furnace needs more heat for redistribution.
- Recombination of CO to COS, and H₂ and S₂ to H₂S releases additional heat in front of several feet of boiler tubes, which is not predicted by some simulators. It increases the heat flux near the critical tube-to-tube sheet weld (maximum metal temperature), and inlet tube sheet refractory and ferrules (maximum heat flux in tubes) requiring mechanical attention.
- Improved heat transfer as a result of the higher radiant film coefficient.
- Steam drum size, downcomer/riser size and number, nozzle sizes, associated piping and instrumentation should all be evaluated.
- Relief capacity, BFW/steam rate will be increased.
- Mass velocities should not be exceeded or heat flux issues may arise, which may cause vapour blanketing of the tubes and high temperature in the tube and tube-sheet.

- The peak heat flux occurs at the outlet of the ceramic ferrules; therefore, the heat flux should be limited to a maximum 50,000 to 70,000 Btu/hr-ft² to prevent eddying.
- The temperature of tube to tube-sheet weld should be limited and evaluated for the possibility of sulphidic corrosion of carbon steel.

Claus catalytic stages

The gas leaving the reheaters enters the Claus catalytic reactors. Oxygen enrichment has the following impact on the Claus catalytic stages:

- Larger temperature rises across the reactors and higher sulphur partial pressures. Since the Claus reaction is favoured by lower temperatures, having a higher sulphur partial pressure increases the extent of the Claus reaction.
- The volumetric flow will be the same, but there is more sulphur vapour present in the gas stream.
- The COS and CS₂ hydrolysis will improve due to a higher temperature in the Claus reactors.
- If the conversion of the sulphur plant to oxygen enrichment is for the processing of lean or very lean H₂S acid gas, then the alumina catalyst in the first Claus reactor should be changed to titanium at the bottom, up to 50%, and alumina catalyst at the top to improve the hydrolysis of COS and CS₂.
- When converting the sulphur plant to high-level oxygen enrichment if the outlet piping of the first Claus reactor is carbon steel (CS), the material should be evaluated for changing to stainless steel (SS) or refractory piping due to the higher outlet temperature.

Reheaters and hot gas bypass reheat

The gas leaving the condensers enter the reheaters. The impact of oxygen enrichment on the reheaters having a higher temperature decreases the hot gas by-pass flow. However, the material and thermal stress in the existing piping should still be reviewed for revamp projects.

Claus sulphur condensers

The gas leaving the Claus reactors enters the sulphur condensers. High-level oxygen enrichment will have the following impact on the sulphur condensers:

- The sulphur condenser duties increase, because of the higher inlet temperature.

- Condensers will have a higher mass flux of lb/hr-ft² as a result of higher duties and the target should be defined.
- The No. 1 and No. 2 sulphur condensers may require a higher heat duty. Replacement with a new condenser may sometimes be required. The impact on the other condensers is not significant.
- All relief valves should be re-rated for the new process conditions.
- All the utility lines such as BFW, steam and instrumentation should be evaluated for the new process conditions.
- All sulphur run downs should be evaluated because of the increased sulphur production.

TGU hydrogenation reactor, waste heat exchanger and contact condenser

The function of the hydrogenation reactor is to convert sulphur compounds (mostly SO₂) to H₂S and for the hydrolysis of COS and CS₂. The effect of oxygen enrichment is as follows:

- An increase in the concentration of sulphur compounds in the tail gas feed, results in a larger temperature rise across the hydrogenation reactor and higher duties in the waste heat exchangers and contact condenser.
- Since the SO₂ concentration is higher in the tail gas feed, during conversion to H₂S in the reactor, the water vapour in the reactor is added to the water from the sulphur plant in the tail gas feed.
- There is a significant increase of the heat duty of the contact condenser – cooling loop includes water and air cooler.
- There is a significant increase in water circulation, pump capacity, and piping.
- The pH is noticeably lower due to a higher H₂S and CO₂ partial pressure, and lower NH₃ content.
- The corrosion rate in the warmer sections of the contact condenser should be monitored more frequently.
- The tail gas volumetric flow rate is lower, even though it is required for cooling.
- If the sulphur plant conversion to oxygen enrichment is for the processing of lean or very lean H₂S acid gas, then the unit should be evaluated for a promoted CoMo catalyst for a lower COS outlet.
- For conversion of the sulphur plant to high level of oxygen enrichment, if the outlet piping of the hydrogenation reactor is CS, the material should be evaluated for changing it from CS to SS

Fig. 3: Control system and equipment modifications for low- to medium-level oxygen enrichment

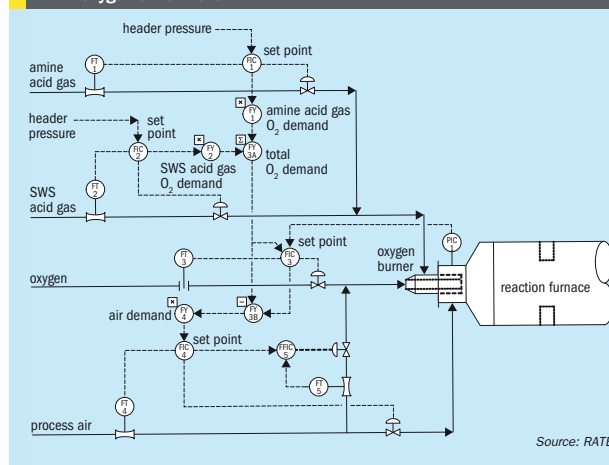

Source: RATE

Fig. 4: Control system and equipment modifications for high-level oxygen enrichment

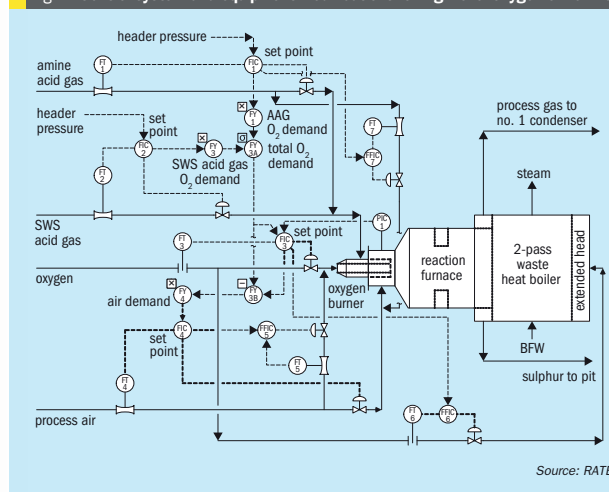

Source: RATE

or CS refractory piping to a higher temperature outlet.

TGU amine absorption and regeneration

The impact of the oxygen enrichment on the TGU amine absorption and regeneration is as follows:

- The feed to the TGU amine unit has a higher H₂S concentration and higher H₂S partial pressure.

- A higher amine circulation rate or higher amine concentration is required.
- More reboiler and overhead condenser duty is required.
- More cooling duty is required in the lean amine circulation loop.
- Piping and instrumentation should be evaluated case-by-case, especially for rich amine piping in terms of velocity, pressure drop, and higher flashing in

the rich solution.

- The capacity of relief valve should be evaluated.
- The flow rate of acid gas from the amine regeneration reflux drum to the SRU is higher; therefore, the reflux drum size, instrumentation, velocity and pressure drop should be checked.
- The rich solvent will have a higher loading; therefore, critical equipment such as lean/rich exchanger should be evaluated for corrosion and erosion.

Incineration

Oxygen enrichment will have the following impact on the incineration system:

- Reduction of the volumetric flow from the amine absorber to the incinerator.
- Increased H₂ concentration and lower N₂ concentration, which reduces the fuel gas demand.
- Increased the SO₂ and water concentration in the stack.
- If the unit is equipped with a degassing unit, the H₂S content of the liquid sulphur will be increased and more H₂S will be routed to the incineration.
- The stack emission for sulphur species should be evaluated to meet environmental regulations.

Liquid sulphur handling/granulation

Oxygen enrichment will have the following impact on the liquid sulphur handling and granulation section:

- Increased sulphur production.
- Rundown piping and sulphur seal pots may require larger size or the existing to be replaced for an additional sulphur production.
- As a result of the higher sulphur production, the sulphur pit residence is reduced. The existing sulphur pit should be evaluated and may require a new sulphur pit, which will require some additional piping.
- The H₂S content of the liquid sulphur will be increased and more H₂S will be routed to the incineration.
- Sulphur pumps require a higher capacity and higher discharge head.
- If the unit is equipped with a degassing unit, the capacity of the degassing unit should be evaluated for the additional sulphur capacity.
- If the unit is equipped with a sulphur granulation unit, the capacity of the solidification and bagging facilities should be evaluated for the additional sulphur production.

Fig. 5: RATE tail gas scheme

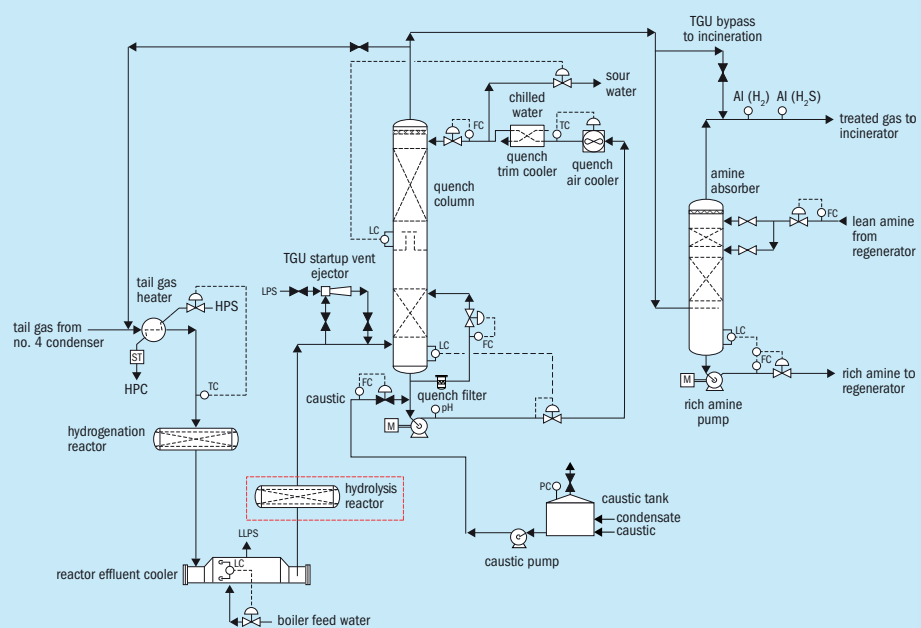

Source: RATE

Fig. 6: Tail gas incineration with caustic scrubber

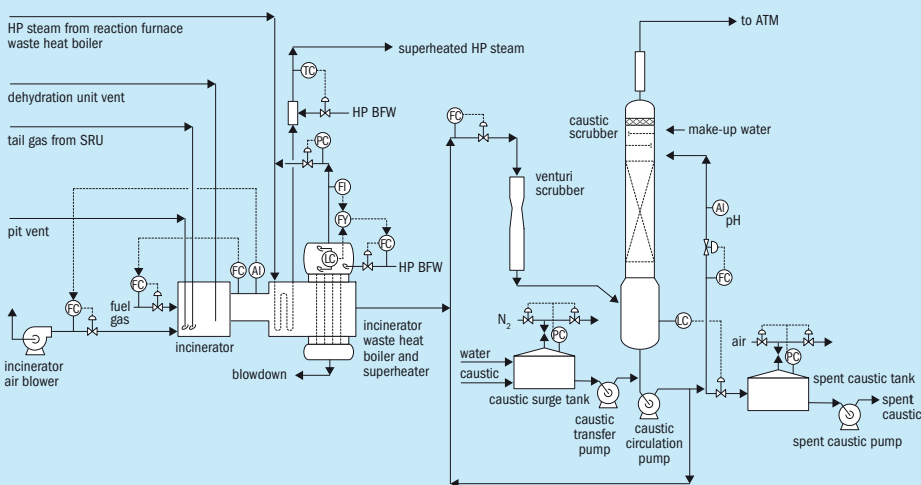

Source: RATE

Fig. 7: SETR technology

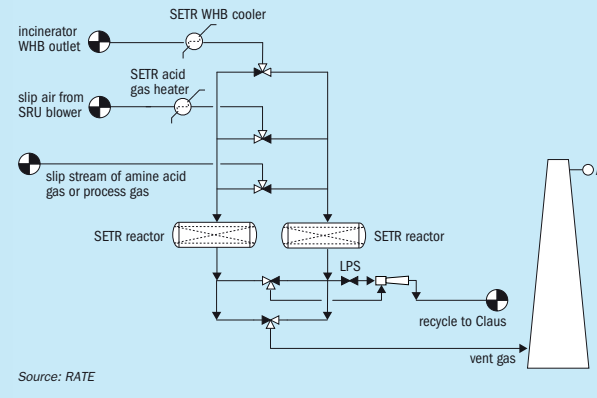

Source: RATE

Controllability

Over the past 20 to 30 years RATE has improved the controllability of its units by incorporating the following primary changes to the controls of sulphur recovery units:

- Use of distributed control systems for controlling the combustion air and acid gas feeds (and other control functions) to the sulphur recovery unit.
- Use of calculation algorithms to calculate actual air or oxygen demands to process the acid gases in the sulphur recovery unit (including capability of adjusting air demands for compositional changes in acid gases).
- Use of calculation algorithms to regulate the flows of sour water stripper gas and amine to front and rear chambers of the reaction furnace to provide optimal operating temperatures in the reaction furnace to thermally decompose ammonia in the first chamber by splitting the acid gases.
- Use of "smart" type flow transmitters with pressure and temperature compensation to provide more accurate flow rates with automatic conversion to mass flow rates and also to provide greater turndown capability – turndown of 6 or 7 to 1.
- Use of improved H₂S/SO₂ analysers for more reliable trim air controls.
- Use of venturi type flow meters in acid gas and air streams to provide greater accuracy at turndown rates.
- Use of three element boiler feed water controls for waste heat boiler controls.
- Use of both special thermocouple designs and optical pyrometers for the reaction furnace

- Use of the latest flame scanner technologies for reaction furnace flame detection.
- Adaptive gain control on the tail gas analyser trim control
- Multi-variable control for the sulphur plant.
- Advanced control technology.

Oxygen piping criteria

Most oxygen piping systems are made of steel or stainless steel materials and operate at pressures of 1,000 psig/69 barg or less and temperatures below 200°F/93°C. Stainless steel has the maximum allowable velocity in the pipe. The oxygen valves are chosen from Monel or Inconel, which are permitted at the high velocity and pressures up to 1,000 psig. Oxygen piping systems should be kept as simple as possible, with the smallest possible number of valves, fitting, branches and nozzles. All process control valves should be in throttling service. Only globe valves or needle valves should be used for throttling.

Figs 3 and 4 represent the control system and equipment modifications for using low to medium-level and high-level of oxygen enrichment respectively.

SO₂ emission reduction

The final step to consider when considering an increase of H₂S to the sulphur recovery unit or a capacity expansion is how to maintain or lower the SO₂ emission. Options include changing the amine solvent in the tail gas unit, routing the pit

vent to the reaction furnace and using a patented tail gas scheme where the hydrolysis reactor is added after the hydrogenation reactor since the COS and CS₂ are not fully hydrolysed in the hydrogenation reactor and operating data shows that at least 30-50 ppmv of SO₂ comes from COS, CS₂, and sulphur species. The hydrolysis reactor can have a common shell with the hydrogenation reactor (see Fig. 5).

Another option is to have tail gas incineration with a caustic scrubber system, which would eliminate changing the solvent and maybe other modifications. The caustic scrubber is added after the incinerator and before the stack as shown in Fig. 6).

Finally, SETR is a new US Patent technology by RATE for application where low emissions of SO₂ are required. SETR is an SO₂ adsorption-based Claus tail gas process with fixed bed reactors that are heated up and cooled down. SETR is located after the incinerator and before the stack as an alternative to caustic scrubbing systems. SETR can be added to any SRU such as SRU/TGU, SMAX, SMAXB, SuperClaus, EuroClaus, CBA, SuperSulf, or any other sub dew point processes. The advantages are no waste stream, no chemical requirements, and all the sulphur is recovered and recycled back to the Claus unit (Fig. 7).

Summary and conclusions

This article discusses the impacts on sulphur recovery as a result of implementing IMO 2020 compliance globally. The most important and obvious impacts are the new investments that need to be allocated, many of which are not cost effective and are too difficult to meet such regulations.

The most common practice used by the shipping industry for compliance is to use a caustic scrubbing system when at the port and to use sea-water scrubbing when away from the port and moving on the water.

If facilities like refineries are required to meet IMO 2020 fuel specifications, they may need to perform modifications to the hydrotreating and sulphur block. The extent of such modifications should be evaluated case by case, sometimes they operate under design capacity so they have enough capacity to take more sulphur out. Sometimes the original design are based on much heavier crude oil and over the years changed to less heavier crude and have the capacity to process more without any modifications.

WORLEY COMPRIMO

Revamp and capacity increase of a sulphur complex in East Asia

G. Bloemendal

Worley Comprimo was approached a couple of years ago by a refinery in East Asia to revamp an existing sulphur complex that was built in the late 1980s with the aim to increase the capacity, improve the availability and reliability and make the unit environmentally compliant. The sulphur complex processed the rich solvent and sour water from an upstream system that was debottlenecked to increase production. The challenges that were faced are described in this article.

The sulphur complex consisted of two amine regenerators, one SWS, two identical SRU trains and two identical TGT trains with a catalytic incinerator. For the whole complex, the target was to increase the capacity by 25% (amine circulation, sour water processing, amine acid gas and sour water acid gas).

Amine regenerator no. 1 was a two-stage regenerator that produced lean solvent for the refinery absorbers and superlean solvent for the TGT absorbers. With the superlean solvent, an H₂S slip of less than 10 ppmv could be achieved in the TGT absorbers. A new flash drum was installed to provide adequate solvent degassing/de-oiling to minimise hydrocarbons in the amine acid gas. In the regenerator overhead new trim coolers were installed to cater for the increased condensing duty. For these trim coolers welded plate-and-frame exchangers were specified to minimise plot space requirements. Also, the reboilers and the superlean trim coolers were replaced with welded plate exchangers for minimal footprint and maximum duty, whereas for the lean solvent cooling an additional welded plate trim cooler had

to be installed. The internals of the column needed minor rework to handle the increased reboiler steam (new inlet device), but the trays were generously designed originally and could be maintained.

Amine regenerator no. 2 had been generously designed both from an equipment perspective and from a layout perspective, so here the revamp was limited to replacing the reboiler (kettle for kettle) with a larger heat transfer surface. The overhead condenser was extended with an additional welded plate trim cooler, as was the lean solvent cooler.

Although it was originally planned to design a new sour water stripper, this stripper was not built for budget reasons. By sharing the sour water load with other strippers in the refinery, the required sour water capacity could be managed without installing an additional sour water stripper.

For the Claus section of the sulphur recovery units, low level oxygen was introduced. Low level oxygen enrichment has the benefit that the hydraulic load in the catalytic stages stays more or less constant, since less inert nitrogen is passing through the unit. Typically, the capacity of the unit can be raised by up to 35%. However, with oxygen enrichment substantially more heat is released in the thermal reactor, which leads to temperatures that are too high in the outlet from the thermal stage process gas cooler/condenser. The complete thermal stage, including the knock-out drums, was therefore replaced with a new, state-of-the-art thermal stage, including air preheating, which was required to enable recycling the vent air from the new pressurised degassing system in the combustion airline. (Worley Comprimo

favours recycling the vent air to the combustion airline over injecting the vent air into the thermal reactor to avoid improper mixing and potential oxygen slip). The control system of the thermal reactor was upgraded to an advanced burner control (ABC) system. The ABC is organised in such a way that the back pressure of the unit is always at a constant high level when in enrichment mode, thus maximising the hydraulic load of the plant and minimising the oxygen consumption. No changes were made to the three catalytic Claus stages.

The sulphur run-down to the sulphur pit was maintained, but the in-pit degassing was eliminated as it was insufficient to meet the typical industry accepted degassing value of 10 ppmw H₂S, making the sulphur pit a storage pit. From this pit, the undegassed sulphur was pumped to an external degassing drum which operates at elevated pressure, such that the vent air from the drum can be routed to the thermal reactor instead of to the catalytic oxidiser. The vapour space of the pit was still vented with an ejector to the new thermal oxidiser, but since the degassing no longer takes place in the pit the vent air contains little to no sulphur species, such that the flue gas spec of 50 ppmv SO₂ can still be met.

The TGT and the catalytic oxidiser were highly integrated with a gas/gas heat exchanger heating the tail gas to the TGT reactor against the flue gas from the catalytic oxidiser. The TGT reactor was loaded with conventional catalyst which required an inlet temperature of 280°C. By changing out the catalyst with a best-in-class low temperature catalyst, the inlet temperature could be reduced to 210-220°C, which opened up the

possibility to replace the gas/gas exchanger with a 40 bar steam heater.

Fig. 1 shows the original setup with a catalytic oxidiser and gas/gas exchanger and Fig. 2 shows the new arrangement with a steam heater/thermal oxidiser with a 40 bar process gas cooler.

The original TGT design had a blower for start-up and low throughput operation which had proved to be unreliable. The blower line-up was retained, however, an ejector was installed in the outlet of the TGT process gas cooler outlet that could fulfil the same service with a very high reliability. With the installation of the ejector, the blower effectively has become idle.

Since the process gas from an oxygen enriched Claus unit contains less inerts and more water vapour, which needs to be condensed before the gas can be routed to the absorber, the duty on the quench water cooler increased substantially, and hence the shell and tube quench water cooler was replaced with a welded plate and frame exchanger which can do the larger duty on a smaller footprint.

To minimise the pressure drop over the complete Claus and TGT unit and to

improve the absorption efficiency (which is required due to the fact that with oxygen enrichment the H₂S concentration to the absorber increases), the trays in the TGT absorber were replaced with structured packing. By doing so the oxygen demand of the thermal reactor was minimised, as well as the slip of H₂S from the TGT absorber, allowing the requested limit of 50 ppmv SO₂ in the flue gas to the stack to be met.

Since the catalytic oxidiser was no longer environmental compliant due to the high CO slip it was replaced with a thermal oxidiser followed by a process gas cooler generating 40 bar steam. This steam is partly used in the TGT reheater, and the excess is routed to the refinery grid. Since the plot space that was freed up by removing the catalytic oxidiser was limited it was decided to build the process gas cooler on top of the thermal oxidiser.

After the basic engineering was finished by Worley Comprimo, the detailed engineering was done by a local contractor. All the above-described changes were implemented during a 20 week shutdown, after which the unit was smoothly started up again.

During the test run that was done after

stabilising the unit all emissions and product specifications were met, i.e. SO₂ in the flue gas was less than 50 ppmv, NOx was less than 50 ppmv and CO was even less than 20 ppmv. The produced sulphur contained less than 10 ppmwt H₂S.

This revamp has shown that welded plate and frame exchangers have very good performance in amine systems, since they combine a high duty with a small footprint, making them ideal for replacing existing shell-and-tube exchangers.

The increased capacity can be easily handled with low level oxygen enrichment, however, the increased thermal duty makes it typically necessary to at least change out the process gas cooler.

The increased capacity can be easily handled in the TGT, and only some additional cooling in the quench circuit is required to handle the additional condensing of process water from the tail gas.

The replacement of the catalytic oxidiser with a thermal oxidiser with heat recovery opened up the opportunity to simplify the operation of the TGT, while at the same time making the complex environmentally compliant.



CHEMETICS®

ISO-FLOW™ Trough Distributors with SWIFT-LOCK™

Experience:

- Next generation Orifice distributor introduced in 2011
- Developed and patented by Chemetics

Features and Benefits:

- Orifice distribution provides consistent flow to each downcomer
- Air gaps provide hydraulic separation and allow for easy troubleshooting
- Calming plates promote even distribution
 - Integral screens catch chips to minimize plugging and allow easy cleaning
 - Internal channel minimises header pipes
- SWIFT-LOCK™ system
 - Reduces distributor installation time by 50%
 - Simplifies tube bank installation/removal – time reduced by 90%
 - Eliminates 90% of nuts/bolts/washers
- SARAME™ Construction for excellent acid corrosion resistance

The ISO-FLOW™ Trough Distributor is designed to be installed through tower manways and is ideal for retrofits.

Innovative solutions for your Sulphuric Acid Plant needs

Chemetics Inc.
(headquarters)
Vancouver, British Columbia, Canada
Tel: +1.604.734.1200 Fax: +1.604.734.0340
email: chemetics.info@worley.com

Chemetics Inc.
(fabrication facility)
Pickering, Ontario, Canada
Tel: +1.905.619.5200 Fax: +1.905.619.5345
email: chemetics.equipment@worley.com

www.worley.com/chemetics

Chemetics Inc., a Worley company

Fig. 1: Original line-up

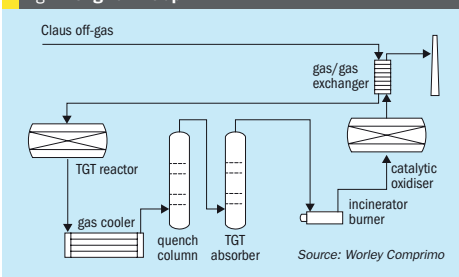

Source: Worley Comprimo

Fig. 2: New line-up (post revamp)

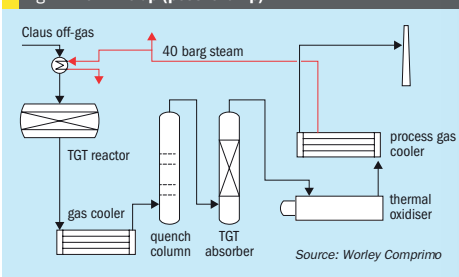

Source: Worley Comprimo

CONTENTS

What's in issue 394

COVER FEATURE 1

Sulphur market update

COVER FEATURE 2

India's acid demand

COVER FEATURE 3

SRU revamping

COVER FEATURE 4

Wet gas cleaning

SULPHUR
ISSUE 394
MAY-JUNE 2021

BCInsight

Southbank House, Black Prince Road
London SE1 7SJ, England

Tel: +44 (0)20 7793 2567

Fax: +44 (0)20 7793 2577

Web: www.bcinsight.com
www.bcinsightsearch.com

Advertisers' index

Editor: RICHARD HANDS
richard.hands@bcinsight.com

Technical Editor: LISA CONNOCK
lisa.connock@bcinsight.com

Contributor: MEENA CHAUHAN
meena.chauhan@argusmedia.com

Publishing Director: TINA FIRMAN
tina.firman@bcinsight.com

Subscription rates:
GBP 440; USD 880; EUR 680

Subscription claims:
Claims for non receipt of issues must be made within 3 months of the issue publication date.

Sales/Marketing/Subscriptions:
MARLENE VAZ
Tel: +44 (0)20 7793 2569
Fax: +44 (0)20 7793 2577
marlene.vaz@bcinsight.com
Cheques payable to BCInsight Ltd

Advertising enquiries:
TINA FIRMAN
tina.firman@bcinsight.com
Tel: +44 (0)20 7793 2567

Agents:
Japan: (also subscription enquiries)
KOICHI OGAWA
O.T.O. Research Corporation
Takeuchi Building
1-34-12 Takadanobaba
Shinjuku-Ku, Tokyo 169, Japan
Tel: +81 3 3208 7821
Fax: +81 3 3200 2889

Previous articles from *Sulphur* from 1995 to the present are available digitally in PDF format. To make a purchase, or for a list of available articles, please see: www.bcinsight.com

Copyright
Issued six times per year, or bi-monthly. All rights reserved. No part of this publication may be reproduced, stored in a retrieval system or transmitted in any form or by any means – electronic, mechanical, photocopying, recording or otherwise – without the prior written permission of the Copyright owner.

ISSN: 0039-4890

Design and production:
JOHN CREEK, DANI HART



Printed in England by:
Buxton Press Ltd
Palace Road, Buxton, Derbyshire,
SK17 6AE

© 2021 – BCInsight Ltd

BCInsight

Published by: BCInsight Ltd
China Works, Unit 102,
100 Black Prince Road,
London SE1 7SJ, UK
Tel: +44 (0)20 7793 2567
Fax: +44 (0)20 7793 2577
Web: www.bcinsight.com
www.bcinsightsearch.com

Advertiser	Page	Website
Argus Media	21	argusmedia.com
BRIMSTECH CORPORATION	IBC	brimstech.com
Clark Solutions	15	clarksolutions.com
Desmet Ballestra SpA	17	desmetballestra.com
Dupont Clean Technologies	9	cleantechnologies.dupont.com
HUGO PETERSEN GmbH	OBC	hugo-petersen.de
IPCO Germany GmbH	5	IPCO.com
ITT Rheinutte Pumpen GmbH	29	rheinuette.de
KVT Process Technology	43	kvt.technology/en/
Siirtec Nigí SpA	39	siirtecnigi.com
Worley Chemetics	IFC	worley.com/chemetics
Worley Chemetics	49	worley.com/chemetics

Next issue: July/August 2021

- Sulphur forming project listing
- Crude oil to chemicals – the future of refining?
- Sulphuric acid alkylation
- Emissions management in metallurgical acid plants
- Spotlight on SRU thermal reactor and was heat boiler

Closing date for advertisement space booking is 2 July 2021
For further information and to book advertisement space contact:
Tina Firman, Publishing Director: tina.firman@bcinsight.com
Tel: +44 (0)20 7793 2567 Fax: +44 (0)20 7793 2577

BRIMSTECH
CORPORATION

Welcome to
the next ERA of
Sulphur Solidification

forthcoming

CONTENTS

What's in issue 394

COVER FEATURE 1

Sulphur market
update

COVER FEATURE 2

India's acid
demand

COVER FEATURE 3

SRU revamping

COVER FEATURE 4

Wet gas cleaning

SULPHUR
ISSUE 394
MAY-JUNE 2021

BCInsight

Southbank House, Black Prince Road
London SE1 7SJ, England
Tel: +44 (0)20 7793 2567
Fax: +44 (0)20 7793 2577
Web: www.bcinsight.com
www.bcinsightsearch.com

HUGO PETERSEN
ENGINEERING IS OUR PASSION
Your partner when it comes to sulphuric acid.

Don't forget the next issue
of **Sulphur** July/August 2021

ENVIRONMENT
IMPROVEMENT
ENHANCEMENT
EFFICIENCY
LIFECYCLE



HUGO PETERSEN GmbH
Rheingastrasse 190-196
65203 Wiesbaden

Tel. +49 (611) 962-7820
Fax +49 (611) 962-9099
contact@hugo-petersen.de

WWW.HUGO-PETERSEN.DE

A subsidiary of



Chemicalanlagenbau Chemnitz GmbH



CONTENTS

What's in issue 394

COVER FEATURE 1

Sulphur market
update

COVER FEATURE 2

India's acid
demand

COVER FEATURE 3

SRU revamping

COVER FEATURE 4

Wet gas cleaning

SULPHUR
ISSUE 394
MAY-JUNE 2021

BCInsight

Southbank House, Black Prince Road
London SE1 7SJ, England

Tel: +44 (0)20 7793 2567

Fax: +44 (0)20 7793 2577

Web: www.bcinsight.com
www.bcinsightsearch.com