

1
2
3
4
5
6
7
8
9
10
11
12
13
14
15
16
17
18
19
20
21
22
23
24
25
26
27
28
29

Welcome to our interactive version of **Sulphur** Issue 392

Please use either the buttons on the left or top right of the page to navigate your way around this interactive PDF

IMPORTANT INFORMATION:
Copyright – Issued six times per year, or bi-monthly. All rights reserved. No part of this publication may be reproduced, stored in a retrieval system or transmitted in any form or by any means – electronic, mechanical, photocopying, recording or otherwise – without the prior written permission of the Copyright owner.



www.sulphurmagazine.com

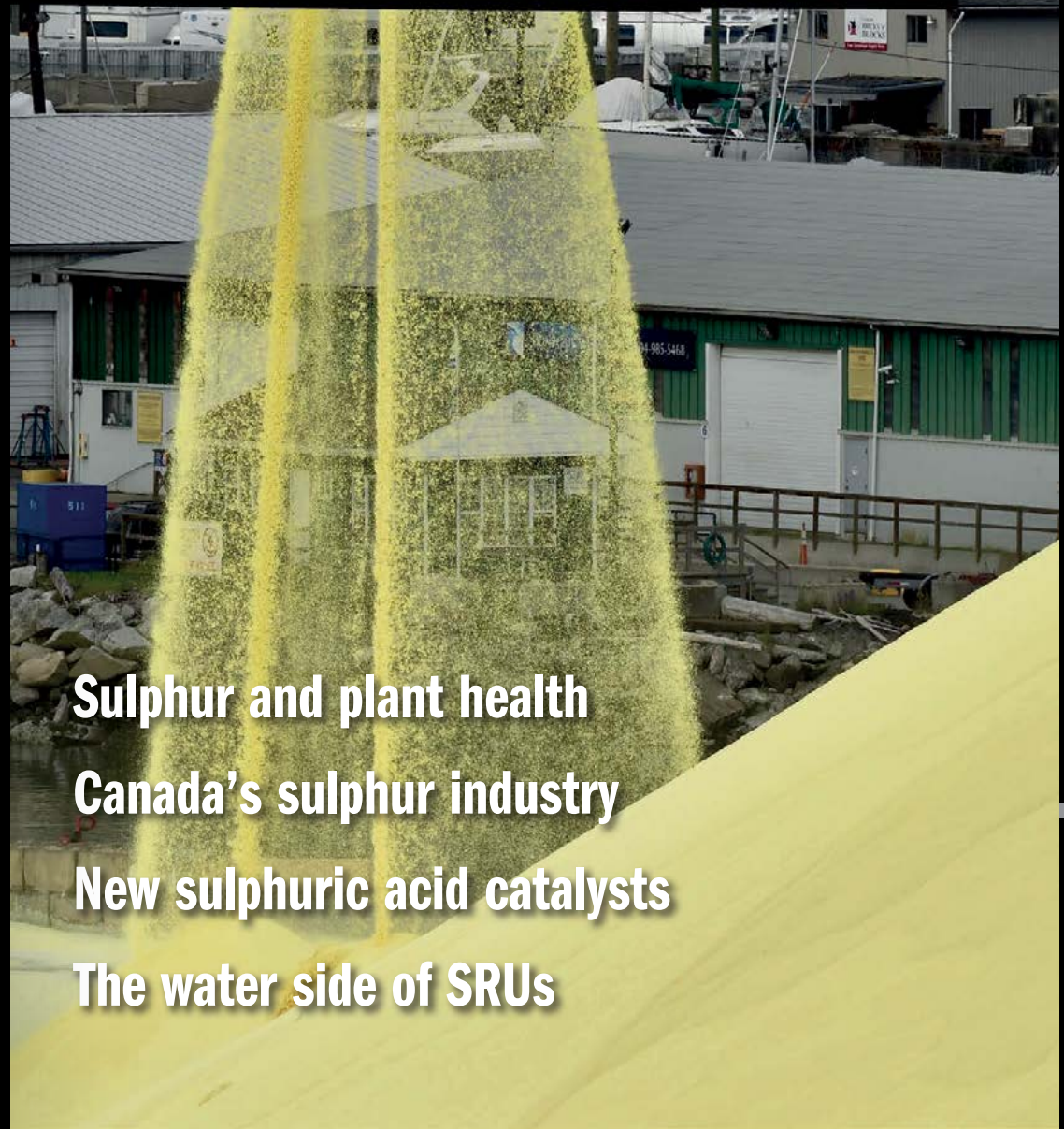

Sulphur and plant health
Canada's sulphur industry
New sulphuric acid catalysts
The water side of SRUs



CONTENTS

What's in issue 392

COVER FEATURE 1

Sulphur and plant health

COVER FEATURE 2

Canada's sulphur industry

COVER FEATURE 3

New sulphuric acid catalysts

COVER FEATURE 4

The water side of SRUs

SULPHUR
ISSUE 392
JANUARY-FEBRUARY 2021

BCInsight

Southbank House, Black Prince Road
London SE1 7SJ, England
Tel: +44 (0)20 7793 2567
Fax: +44 (0)20 7793 2577
Web: www.bcinsight.com
www.bcinsightsearch.com

We are everything sulphur

As the recognized world leader for sulphur-related projects, Worley has over 65 years of providing **unique total sulphur and sulphuric acid management solutions** globally. Worley can provide leading technology, plants, equipment and solutions for all parts of the sulphur chain. We are everything sulphur.

Comprimo® Sulphur, Chemetics® Sulphuric Acid, and Advisian Port and Logistics solutions provide world wide focus on site reliability, environmental solutions, plant economics and workforce development.

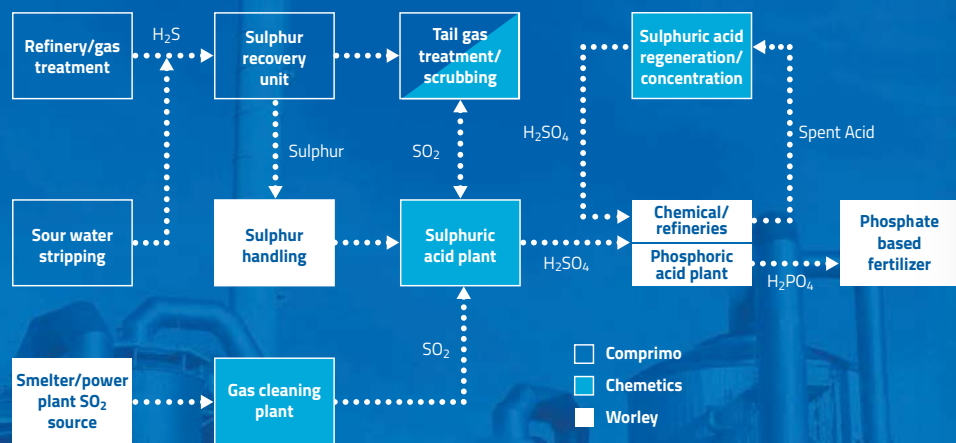

The Hague Vancouver London Toronto Calgary Perth Los Angeles Mumbai Santiago

worley.com/comprimo

worley.com/chemetics



Cover: mauinow1/iStockphoto.com



Plant nutrient sulphur

The missing ingredient in agriculture?



Sulphuric acid catalysts

Advanced catalyst shapes and new formulations improve efficiency.

Read this issue online at:
www.sulphurmagazine.com

Published by:
BCInsight

SULPHUR

www.sulphurmagazine.com

NUMBER 392

JANUARY | FEBRUARY 2021

CONTENTS

- 9 Is sulphur the missing ingredient?**
Ron Olson of The Sulphur Institute considers sulphur's important role in plant health.
- 11 Canadian sulphur**
After many years of slow decline, Canadian sulphur exports have begun to rise slightly, but dwindling US markets are seeing a move towards more sulphur forming to expand export opportunities.
- 12 Sulphur + Sulphuric Acid 2020**
The coronavirus outbreak necessitated a 'virtual' CRU Sulphur + Sulphuric Acid conference last year, held in November 2020.
- 13 China's phosphate industry**
Continuing rationalisation in China's phosphate industry has been reducing demand for sulphur and sulphuric acid at the same time that the country is producing more of both.
- 14 Sulphur 2020 index**
A full listing of all news items and articles published in *Sulphur* last year.
- 15 New catalysts target key industry challenges**
Catalyst design and formulations continue to evolve with Haldor Topsoe, DuPont Clean Technologies and BASF all adding new types of sulphuric acid catalysts to their portfolios.
- 19 SRU troubleshooting tools**
Process and simulation models can be valuable tools when troubleshooting to solve operational issues in sulphur recovery units. Examples are provided by Sulfur Recovery Engineering and Optimized Gas Treating.
- 20 Fire prevention and suppression for molten sulphur tanks and pits**
D. J. Sachde, K. E. McIntush, C. M. Beitler, and D. L. Mamrosh of Trimeric Corporation review fire suppression methods used in the industry including snuffing/sealing steam, rapid sealing, water mist, and inert gas blanketing. Protective tank design features to reduce the likelihood of a sulphur fire are also reviewed.
- 24 Hidden opportunity: the water side of sulphur recovery units**
Failure investigations, equipment design and process upgrade projects for SRUs often overlook the impact of water quality. E. Nasato of Nasato Consulting and L. Huchler of MarTech Systems explore impacts of higher heat transfer rates, control of boiler and condenser water chemistry, conventional equipment design/configurations and monitoring program designs.

REGULARS

- 3 Editorial** It's not over yet
- 4 Price Trends**
- 5 Market Outlook**
- 6 Sulphur Industry News**
- 7 Sulphuric Acid News**
- 8 People/Calendar**

CONTENTS

What's in issue 392

COVER FEATURE 1

Sulphur and plant health

COVER FEATURE 2

Canada's sulphur industry

COVER FEATURE 3

New sulphuric acid catalysts

COVER FEATURE 4

The water side of SRUs

SULPHUR
ISSUE 392
JANUARY-FEBRUARY 2021

BCInsight

Southbank House, Black Prince Road
London SE1 7SJ, England
Tel: +44 (0)20 7793 2567
Fax: +44 (0)20 7793 2577
Web: www.bcinsight.com
www.bcinsightsearch.com

It's not over yet



The turning of a new calendar year is a predictable waypoint in our lives. That is why it has always traditionally been a time for reflection on the past and looking to the future. Therefore, given how 2020 had turned out, perhaps there was an inevitable hope that the turning of the New Year and the start of 2021 might see an improvement in things in general, and of course the trajectory of the pandemic in particular, especially now that several vaccines have been approved for use in record time, and a massive programme of vaccination has begun across the world.

However, reality is rarely as neat and tidy as that, and while the vaccines offer some hope of a return to a more normal existence later this year, whatever that might eventually look like, at the moment Europe and North America are in the grip of a second wave of the pandemic even deadlier than the first, exacerbated by the closer proximity forced upon people by the cold winter temperatures, a spike due to the mixing and spreading of families during the holiday period, and now new mutant strains of the virus that have emerged in the UK, South Africa and Brazil, and which spread with even greater ease, though which fortunately do not seem – as yet – to have developed any resistance to the various vaccines.

This new more sobering reality makes many of last year's economic forecasts for this year begin to look increasingly over-optimistic. A lot of projections for, for example sulphur supply and demand were based on assumptions that there would be a recovery which began in the early months of this year, in areas such as oil demand and hence refinery output, as well as a number of completions and start-ups of major projects during the year that had slipped from 2020 to 2021 because of the difficulty of getting engineers and equipment to the right places. These assumptions are starting to look less likely now, with the possibility that we may see continued supply disruption at least until 3Q 2021. Some Middle Eastern economies which are sites of major projects are seeing dramatic cuts in government revenue due to low oil prices, and are having to make economies, while in Europe and North America some marginal refineries are facing potential closures.

Demand, conversely, seems to have held up relatively well, contingent as it is mainly on agriculture, something that has had a much greater priority for governments everywhere – people do not necessarily need to drive or fly, but they do need to eat. This has meant that surpluses which have affected many fertilizer markets have begun to dry up, lifting prices.

Beyond covid, other geopolitical issues loom, such as how the Biden presidency will handle the ongoing trade dispute with China, which is also weighing heavily on the world economy; the nuclear ambitions of Iran, and the associated sanctions regime that has disrupted regional trade; and the move to alternative energy sources amid a planned return to the Paris climate agreement that the Trump presidency took the US out of. There is also the question of OPEC's response to the oil demand collapse. Last year the cartel cut its output by 9.7 million bbl/d, in conjunction with Russia and the US, but relaxed this back to a 7.2 million bbl/d cut in the early days of January 2021 on the anticipation of a return of demand. Now however Saudi Arabia is talking about another 1 million bbl/d cut to stop inventories from building up.

Many optimistic forecasts are still out there. The World Bank is still predicting 4.3% global growth this year, and just last week PricewaterhouseCoopers was talking of a "Great Rebound" and a return to a pre-pandemic economic level for the world economy by the end of 2021. However, if the pandemic has taught us anything, it's that the only thing that is certain is that it's not over yet.

Richard Hands, Editor



Building on its latest acquisitions, Axens Group offers a broader range of solutions that enhances the profitability and environmental performance of its clients. www.axens.net



CONTENTS

What's in issue 392

COVER FEATURE 1

Sulphur and plant health

COVER FEATURE 2

Canada's sulphur industry

COVER FEATURE 3

New sulphuric acid catalysts

COVER FEATURE 4

The water side of SRUs

SULPHUR
ISSUE 392
JANUARY-FEBRUARY 2021

BCInsight

Southbank House, Black Prince Road
London SE1 7SJ, England
Tel: +44 (0)20 7793 2567
Fax: +44 (0)20 7793 2577
Web: www.bcinsight.com
www.bcinsightsearch.com

Price Trends



MARKET INSIGHT

Meena Chauhan, Head of Sulphur and Sulphuric Acid Research, Argus Media, assesses price trends and the market outlook for sulphur.

SULPHUR

The upward trend in global pricing has continued into the new year showing little sign of dissipating in the short term. The holiday season slowed the market temporarily but focus remained on the outcome of first quarter 2021 contract negotiations. The global pandemic has continued to impact broader macroeconomic sentiment although progress in the development and approval of vaccines in some countries led to higher oil prices in December. Rising cases of Covid-19 in some countries despite new vaccine roll outs is also adding uncertainty and concern.

Sulphur supply in the Middle East remained tight through much of the first quarter of 2020, leading to a firm footing in spot prices. Average prices in December 2020 were \$93/t f.o.b. in the region, up \$30/t on average prices at the end of the third quarter. Expectations are for this trend to continue in the short term, with first quarter contracts setting the tone for a firm short term view. Middle East producer pricing for December 2020 reflected the tighter market and more bullish sentiment. In the UAE, ADNOC set its December monthly price at \$80/t f.o.b. Ruwais, \$6/t up on November, for shipments to the Indian market. KPC/Kuwait set its price at \$83/t f.o.b. Shuaiba, up by \$10/t on the previous month. State-owned marketer Muntajat set its December Qatar Sulphur Price (QSP) at \$86/t f.o.b. Ras Laffan/Mesaieed. This was \$14/t above November. Muntajat has also announced its January 2021 price in the three digits at \$101/t f.o.b. The spot tender for December shipment attracted several bids from the high-\$90s/t to \$102/t f.o.b. A softer tone is likely to emerge from February as major buyers in China exit the market for the lunar new year holiday.

On the supply side, Kuwait's KNPC completed its long-awaited Clean Fuels Project (CFP). Sulphur capacity in Kuwait is set to rise above 2 million t/a as a result. Additional sulphur volumes have yet to be heard offered for export but the coming months are likely to see progress. Qatar's Barzan project appears to be seeing further delays, with start up pushed to Q2 2021 from an end 2020 estimate. Once online, this would bring 0.8 million t/a sulphur capacity.

continue as domestic production rises from the oil refining sector in the outlook.

Elsewhere in Asia there are mixed reports regarding the domestic supply situation in India. Some refiners were heard ramping up operating rates at the end of 2020 but the prevalence of sweeter, lighter crudes kept sulphur recovery reduced. Major domestic producer Reliance was understood to be in contract negotiations for supply in 2021 with no outcome heard by the start of the new year. Indian spot prices were assessed at \$111-118/t c.f. at the end of 2020, up on an average of \$82/t c.f. at the end of the third quarter.

First quarter contracts were in the early stages in December for North African buyers. Broad expectations were for prices to be agreed on an increase on the fourth quarter. North African spot prices have firmed in line with the export price uptick, supporting the view for higher contract prices. Spot prices increase by \$27/t on average in December to \$97/t c.f. North Africa compared with the end of the third quarter. Prices on the high end were assessed at \$105/t c.f. at the end of 2020. Another supporting factor is the seasonal tightness from the Russia/Central Asian region over the winter months.

The ruling by the US Department of Commerce to place preliminary duties on US imports of Moroccan and Russian phosphates is not expected to impact OCP's sulphur requirements. OCP is expected to change its trade flows over time, focusing on exporting finished fertilizers east of Suez and into Latin America while continuing to cover demand in Africa. Morocco is set to remain a sulphur import hotspot with growth forecast for the year ahead. Trade data shows sulphur imports in January – October 2020 sulphur imports to Morocco totalled 6.1 million tonnes, up by 7% on the same period a year earlier.

Over in Tunisia protests in the second half of 2020 have hampered GCT's processed phosphate operations at the Gabes facility. A question mark hangs over potential sulphur consumption levels in the year ahead. Attention will remain on the outcome of any first quarter negotiations and whether lower volumes will be agreed.

SULPHURIC ACID

Global sulphuric acid prices continued to rise through December amid tight supply for prompt shipments. This trend is expected to remain firm on the back of the supply

squeeze with outages compounding the situation. Sentiment at the end of December 2020 was to see firmer prices through the first half of 2021, assuming the supply balance remained tight. Average NW European export prices for sulphuric acid increased by \$37/t between April and December 2020 to \$27/t f.o.b. This was indicative of the supply/demand balance with support from downstream markets and elemental sulphur also underpinning this trend. Recovery from negative netbacks earlier in 2020 was initially slow and steady but prices accelerated towards in the fourth quarter as liquidity reduced. First quarter contract negotiations for molten sulphur are expected to yield increases on the fourth quarter. Exact levels were still in question at the end of 2020. An uptick in prices would influence sentiment for the domestic sulphuric acid prices.

South Korean and Japanese export prices firmed through December for the third consecutive month on the back of improved international sentiment, with the price range rising to \$10-20/t f.o.b. in December. The gap between East and West export prices has been closing – down to \$15/t compared with \$32/t earlier in the year. Chinese export prices have also strengthened, up at \$15-20/t by mid-December through to the end of the year. Japanese acid exports were estimated at 3.0 million t in January-November 2020, up by 17% on a year earlier. The Philippines led trade at 1.2 million t, up 9% year on year. Shipments to India also show a significant increase at 0.6 million tonnes. Meanwhile decreases were to Chile and Taiwan.

Exports from China remained strong despite low pricing and Covid-19 related disruption earlier in 2020. In January-November 2020 exports were 1.6 million tonnes, down slightly on 1.9 million tonnes a year earlier. Morocco is the leading market at 0.7 million tonnes with volumes increasing by 17% on a year earlier. The post Covid-19 recovery for sulphuric acid production in China is expected to be swift, with development at major copper projects driving the market. Total acid production is estimated to have dropped to 93 million tonnes. In project news, Phase I of the Houman North Copper project in Shanxi started up in November. This will add 0.7 million tonnes/year acid when it reaches capacity. The Yantai Guorun copper project is also set to add 0.7 million t/a of acid capacity from 2021. Trade tensions between Australia and China are being closely watched and may impact acid output at smelters. China has imposed import constraints on Australian copper ore, copper concentrates and other products. The copper concentrate market is expected to be tight in the short term, with falling production in key producing regions. Argus expects China to maintain its net exporter status through the short and medium term outlook.

There are two new speculative smelter projects in India with the potential to add 0.6 million t/a of sulphuric acid capacity. Hindustan Zinc (HZL) has announced plans to commission a new zinc smelter in Doswada, Gujarat and a second project to double capacity at its existing Dariba smelter. In the meantime, Vedanta's Sterlite Tuticorin

smelter in Tamil Nadu remains offline. Uncertainty remains on a potential restart given the length of time the smelter has been out of operation and without maintenance. Indian imports remained strong through 2020, partially to cover the shortfall from Vedanta and also reflecting buyers encouraged by low prices in the first half of the year. Spot prices were assessed at \$43-50/t c.f. at the end of 2020 and averaged \$39/t c.f. for the month of December. This is considerable above levels as low as -\$4/t c.f. in April 2020.

Chile demand for sulphuric acid eroded in 2020 and Argus estimates a 9% fall in the copper sector down to around 8 million tonnes with copper output faltering on the back of Covid-19 related issues. The earlier collapse of finished copper demand as countries across the globe entered lockdowns forced production cuts at mines, furthering the mining activity decline. As producers continue to normalize operating rates, Argus expects demand to recover through 2021. The rise in copper prices and strong demand will likely support market sentiment. Spot prices at the end of December 2020 ranged \$73-80/t c.f., the highest levels on average seen through the year. Chile annual contract settlements for 2021 were heard in a wide range from \$55-65/t c.f. depending on size and delivery terms. A greater proportion of volumes were settled at a midpoint closer to \$58-59/t c.f. and the annual price has been assessed at \$56-62/t c.f., a decrease of \$12/t on the 2020 annual price. It is the smallest year-on-year change in more than five years.

Price Indications

Table 1: Recent sulphur prices, major markets

Cash equivalent	July	August	September	October	November
Sulphur, bulk (\$/t)					
Adnoc monthly contract	59	58	77	77	74
China c.f. spot	78	57	93	95	115
Liquid sulphur (\$/t)					
Tampa f.o.b. contract	58	58	58	69	69
NW Europe c.f.	98	98	107	107	107
Sulphuric acid (\$/t)					
US Gulf spot	43	45	50	53	60

Source: various

CONTENTS

What's in issue 392

COVER FEATURE 1

Sulphur and plant health

COVER FEATURE 2

Canada's sulphur industry

COVER FEATURE 3

New sulphuric acid catalysts

COVER FEATURE 4

The water side of SRUs

SULPHUR
ISSUE 392
JANUARY-FEBRUARY 2021

BCInsight

Southbank House, Black Prince Road
London SE1 7SJ, England
Tel: +44 (0)20 7793 2567
Fax: +44 (0)20 7793 2577
Web: www.bcinsight.com
www.bcinsightsearch.com

Market Outlook

Historical price trends \$/tonne

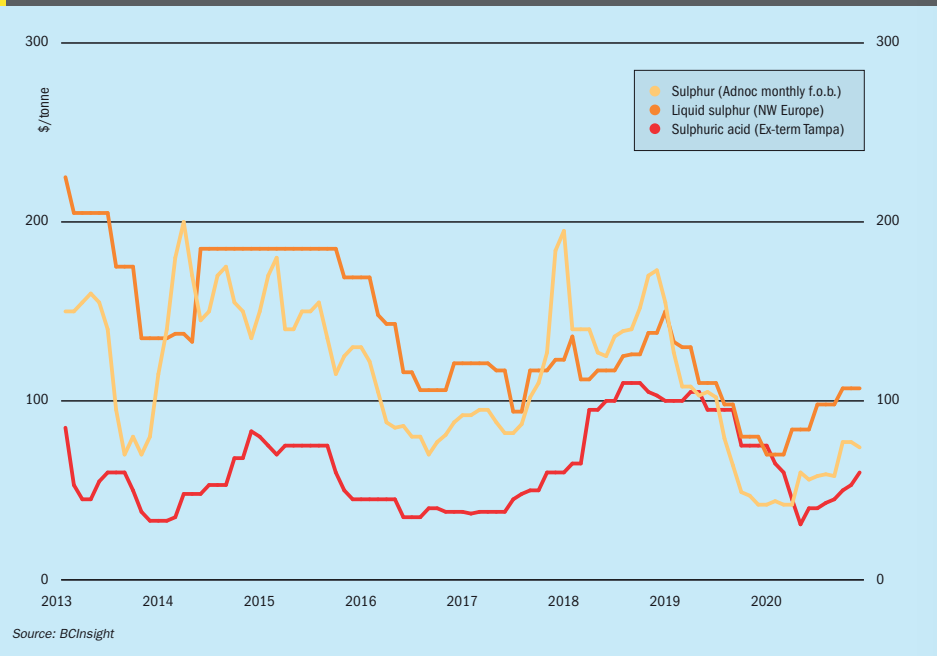

SULPHUR

- The global pandemic and new wave of lockdowns in some regions continue to pose a level of uncertainty to oil demand and in turn sulphur recovery. There are positive signs in the macro economic picture on the back of the vaccine rollout but significant question marks remain.
- Nickel based demand for sulphur at new leaching projects remains a highlight of the market outlook. Indonesia is driving this in the forecast, with several new projects expected to ramp up. Slight delays on the back of Covid-19 disruption may see a more significant ramp up in 2021/2022 for sulphur imports.
- China's burgeoning sulphur production from new refining projects and expansions is at the forefront of the shift in the market balance. The year ahead is expected to see further pressure on the import requirement.
- Growing demand from the processed phosphates sector in North Africa will offset some of the losses from Chinese trade.

- **Outlook:** Short term tightness is expected to prevail and prices to remain stable to firm ahead of the Chinese lunar new year holidays. As trades stall in February the heat in the price run is expected to dissipate. The latter part of 2021 is likely to see increased volumes, based on the assumption of new projects adding export availability in markets including the Middle East. Recent positive developments around the roll-out of Covid-19 vaccines in many countries have spurred optimism about an oil demand recovery. But the emergence of more infectious strains of the virus in Europe and elsewhere have triggered new travel restrictions and lockdowns.

SULPHURIC ACID

- Seasonal tightness in the elemental sulphur market continues to support the sulphuric acid market price outlook going into the first quarter of 2021.
- Indian imports of acid are estimated to have breached the 2 million tonne mark in 2020 with trade data to October totalling 1.8 million t. This is in line with

the low price trend earlier in the year. Strong imports are expected in the year ahead with Sterlite/Tuticorin expected to remain offline through 2021.

- OCP/Morocco is expected to remain a major acid importer in 2021, expected to remain well above one million tonnes based on the outlook for demand.
- Smelter turnarounds are expected to ramp up in 2021 following the delays and reduced levels in 2020. Pockets of tightness are expected to emerge, lending support to pricing.
- **Outlook:** Prices continue to be buoyed going into the new year, with tight supply compounding the uptick. Support from the DAP and sulphur markets is also influencing sentiment. Average prices in Chile for 2020 were \$40/t c.f. following the price run up in the latter part of the year. Developments in the mining sector remain crucial for the short term outlook for supply and demand in Chile with buoyant copper prices remaining supportive. New variants of the Covid-19 virus continue to remain a wild card for the macro economic outlook. ■



End-to-end systems from receipt of molten sulphur to loading of solid material - single source supply by IPCO.

- High capacity liquid sulphur degassing
- Large scale block pouring and high capacity melting solutions
- Premium Rotoform pastillation and high capacity drum granulation
- Downstream storage - silo and open/closed stockpiles
- Custom built reclaimers for any location
- Truck, rail and ship loading and bagging systems

CONTENTS

What's in issue 392

COVER FEATURE 1

Sulphur and plant health

COVER FEATURE 2

Canada's sulphur industry

COVER FEATURE 3

New sulphuric acid catalysts

COVER FEATURE 4

The water side of SRUs

SULPHUR
ISSUE 392
JANUARY-FEBRUARY 2021

BCInsight

Southbank House, Black Prince Road
London SE1 7SJ, England
Tel: +44 (0)20 7793 2567
Fax: +44 (0)20 7793 2577
Web: www.bcinsight.com
www.bcinsightsearch.com

EGYPT

Work begins on hydrocracking complex

Construction work has begun on a new hydrocracking complex for the Assiut refinery in Egypt, in the central Nile valley, according to TechnipFMC plc, who won the \$1 billion engineering, procurement, and construction (EPC) contract for the project. The contract involves construction of new processing units including a vacuum distillation unit, a diesel hydrocracking unit, a delayed coker unit, a distillate hydrotreating unit and a hydrogen production unit which will use TechnipFMC's proprietary steam reforming technology.

The project, which forms part of the Egyptian government's

energy transition strategy, also involves the construction of a sulphur recovery unit (SRU) and sulphur solidification unit as well as on-site and off-site storage areas and interconnecting utilities. Upon completion, the complex will process about 2.5 million t/a of heavy fuel oil from ASORC's nearby 4.5 million t/a (90,000 bbl/d) Assiut refinery to produce approximately 2.8 million t/a of Euro 5 quality diesel and other high-value products including 360,000-400,000 t/a of naphtha, 91,000-101,000 t/a of LPG, and 331,000 t/a of coke. Sulphur recovery will run to between 57,000-66,400 t/a. ■

Start-up for ERC hydrotreating units

Axens reports that all of its units that form part of the Egyptian Refining Company (ERC) refinery project are now successfully operating and have reached full production and performance. The \$4.3 billion refinery, at Mostorod north of Cairo, began operations last year, and produces Euro 5 refined products, including diesel and jet fuel, for the Egyptian domestic market by processing 4.7 million t/a of mainly atmospheric residue from the Cairo Oil Refinery Company. Axens was involved in providing licensing, the process design package, catalysts, proprietary equipment and services for several units, including a naphtha hydrotreating unit, a CCR-reforming unit, a diesel hydrotreating unit, and a single stage hydrocracking unit with recycle achieving high conversion.

"Axens is very proud of the trust expressed by ERC following the provision of Axens' support to operate our technologies in the most efficient way. They demonstrated their confidence in Axens by securing the implementation of Connect'In® digital services which proactively enables the monitoring of Axens units performances," said Patrick Sarrazin, Axens' Process Licensing Global Business Unit executive vice-president.

ERC converts low value fuel oil into middle and light distillates and recovers 96,000 t/a of sulphur.

BELGIUM

Start up for refinery SRU

Frames says that it has supplied, and successfully commissioned, a hydrogen sulphide removal unit, based on the company's proprietary LAMINOL technology, to a refinery in Antwerp, Belgium. Frames says that, in order to comply with the refinery's stringent flue gas SO_x emission limits, various technolo-

gies were evaluated during the conceptual design phase, including flue gas treatment and caustic scrubbers. However, LAMINOL technology was selected as most effective, while meeting the refinery's total cost of ownership requirements. Working to a fast track schedule, the modular H₂S removal system was quickly installed and commissioned.

Instead of treating the flue gas directly, LAMINOL removes sulphur components from the distillation overhead gas containing up to 60% H₂S before it is combusted in the process furnace. Treating the waste gas in a stand-alone modularised unit meant that the unit was much easier to integrate into the existing refinery facility. The gaseous sulphur removed is converted into elementary sulphur in solid form. It is the result of an in-house research and development program initially applied in the biogas market, where it provides a cost-effective alternative to conventional biogas sweetening processes. It is capable of selectively removing H₂S from CO₂ rich gas streams to a few ppm even at near atmospheric gas pressure.

UNITED STATES

Honeywell completes acquisition of Orloff

Honeywell has completed its acquisition of Orloff Engineers, a licensor and developer of natural gas processing and sulphur recovery technologies, for an undisclosed sum. Orloff will become part of Honeywell UOP's Gas Processing and Hydrogen business, bringing expertise in the recovery of high-value natural gas liquids from natural gas streams. Orloff also has several unique technologies for removing sulphur from refinery feedstocks and experience in sour gas process design. The two companies have worked closely together since 2002.

"Orloff complements our existing offerings perfectly, enabling Honeywell UOP to

better meet customer needs for high-recovery NGL extraction plants globally," said Rachelle Goebel, vice president and general manager of Honeywell UOP's Gas Processing and Hydrogen business. "Our joint technology offerings are installed in more than 50 gas plants around the world, allowing our customers to capture the greatest value from their natural gas resources."

Deer Park to idle one SRU in 2021

Royal Dutch Shell Plc says that it plans to idle a sulphur recovery unit at the joint venture Deer Park, Texas, refinery in 2021, according to a company spokesman. The refinery has been operating at about 75% of its nameplate 318,000 bbl/d capacity because of reduced demand due to the covid pandemic. There are six SRUs at the site, one of which will be idled this year.

GERMANY

H+E develops new caustic purification technology

H+E Group, a supplier of industrial process water and wastewater treatment solutions, says that it has developed and successfully installed AquaCritox®, a new technology for the treatment of spent caustic in refineries in conjunction with Super Critical Fluids International (SCFI) Ltd. The caustic is generally highly contaminated with organic loads and usually contains sulphides, mercaptans and phenols. Previously, the company says, purification was difficult or simply not possible. AquaCritox is a high pressure, high temperature hydrothermal oxidation technology originally designed to operate at supercritical water conditions (i.e. above 221 bar and 374°C). The design employs a multistage tubular reactor and a novel pressure control system. In order to overcome issues with high salt content associated with spent caustic the original concept technology was



PHOTO: H+E GROUP

adapted to operate at near critical conditions but below the critical point. It has now been installed and is operating at two sites in the Middle East. Subsequent laboratory results from onsite sampling confirms that efficient destruction of COD, sulphides and mercaptans is achieved. The treated spent caustic is therefore suitable for disposal or further treatment in a biological system.

IRAN

Inauguration of new sulphur recovery project

Iranian president Hassan Rouhani has officially inaugurated the new olefin and sulphur recovery units at the Ilam Petrochemical Plant. Along with other projects also inaugurated in December, these will bring total Iranian petrochemical capacity from 66 million t/a to 77 million t/a, and further projects due for completion by the end of the Iranian year in March are expected to take this to 90 million t/a. At Ilam, the €56 million SRU will sweeten olefins. It will be fed by 349,000 t/a of C3+ fractions and 416,000 t/a of C5+ fraction, and will produce 331,000

t/a of desulphurised C3+ and 401,000 t/a of desulphurised C5+ fractions for production of ethylene, propylene, pyrolysis gasoline and liquid fuels. The unit, licensed by Axens, was built by Iran's Energy Industries Engineering and Design (EIED), with a 72% domestic share of the project, including engineering, construction, installation and manufacturing of equipment.

Among the other projects inaugurated was a potassium sulphate plant at the Urmia Petrochemical complex. The unit will produce 40,000 t/a of potassium sulphate, and 50,000 t/a of hydrochloric acid, and will consume 34,000 t/a of potassium chloride and 22,800 t/a of sulphuric acid. The plant has been licensed by China's CNBM and has designed and built by the Pars Qeshm Arseh Afroz Engineering Company.

UNITED ARAB EMIRATES

Fujairah refinery to start up this year

Brooge Energy says that Fujairah's fourth refinery should come on-stream in 2021. The 25,000 bbl/d refinery will begin producing low sulphur fuel oil in the second half of the year. The port's third refinery

started up in April 2020, a 15,000 bbl/d plant owned by Ecomar Energy Solutions, since expanded to 20,000 b/d.

KAZAKHSTAN

KPO partners settle oil and gas dispute with Kazakhstan

The Karachaganak Petroleum Operating (KPO) consortium, which operates one of Kazakhstan's largest oil and gas fields, has paid \$1.3 billion to settle a long running dispute with the Kazakh government over profit-sharing. The agreement paves the way for the project's investors to move ahead with a \$1.1 billion debottlenecking project which will boost sour gas production by 4 bcm per year. The Kazakh Energy Ministry announced on December 14th that in addition to the cash settlement, KPO had agreed to adjust the production-sharing agreement (PSA) for the Karachaganak field. This will earn the Kazakh state an extra \$600 million in oil and gas sales by 2037, assuming a \$40-50/bbl crude price.

Karachaganak is jointly operated by Royal Dutch Shell and Italy's Eni, each with 29.25% of shares, as well as Chevron, Lukoil and state oil company KazMunaiGas (KMG). The field produced 412,000 barrels of oil equivalent per day of oil and gas in the first half of 2020, putting it in third place behind Tengiz and Kashagan in terms of Kazakhstan's biggest oil and gas projects.

The current dispute dates back to 2015, when Kazakhstan began to complain that falling global oil prices had led to a drop in its returns from the Karachaganak field. A \$1.8 billion claim went to an international arbitration tribunal in Sweden, and the lengthy negotiations have taken until now to finalise. ■



Watch free fertilizer market presentations

Argus deliver concise and insightful webinars analysing the nitrogen, phosphate, potash, sulphur and sulphuric acid markets. The webinars are offered on-demand and live – and are completely free to watch.

Watch the free webinars here: www.argusmedia.com/webinars



CONTENTS

What's in issue 392

COVER FEATURE 1

Sulphur and plant health

COVER FEATURE 2

Canada's sulphur industry

COVER FEATURE 3

New sulphuric acid catalysts

COVER FEATURE 4

The water side of SRUs

SULPHUR
ISSUE 392
JANUARY-FEBRUARY 2021

BCInsight

Southbank House, Black Prince Road
London SE1 7SJ, England
Tel: +44 (0)20 7793 2567
Fax: +44 (0)20 7793 2577
Web: www.bcinsight.com
www.bcinsightsearch.com

RUSSIA

Norilsk closes smelter at Nikel

Norilsk Nickel has finally closed down its nickel smelting operation at Nikel in Russia's Murmansk region; the company's oldest still operating production facility. The shutdown is part of the company's environmental programme, which aims to significantly reduce its environmental impact at all production sites. The Nikel closure will eliminate SO₂ emissions in the cross-border area with Norway, which had become a major bone of contention with the Norwegian government. Norilsk aims to reduce SO₂ emissions at Kola by 50% by the end of 2020 and 85% by the end of 2021, and is modernising its production in Monchegorsk, including the construction of new state-of-the-art facilities.

Following the closure of the Nikel smelter, concentrate from the Zapolyarny concentrator will be delivered instead to concentrate shipment hubs, from where it will be supplied to consumers. Nikel produced 61.8 million tonnes of nickel ore and 2.4 million tonnes of high grade nickel matte over its 74 year history, according to Norilsk.

Meanwhile, Norinickel has awarded Metso Outotec the contract to modernise one of the company's two existing smelting lines at their Nadezhda Metallurgical Plant in Norilsk. The contract value is approximately €90 million, and includes engineering and delivery of a nickel flash smelting furnace and a heat recovery boiler with related automation and advanced digital products. Replacing the existing smelting line with the latest process technology and furnace structures will significantly increase the line's capacity and availability, reduce metal losses and ease maintenance. The new line will also allow for the easy connection and efficient operation with the planned future sulphuric acid production and neutralisation project.

"Norilsk Nickel operates the world's largest nickel and palladium deposit in Russia. We are very committed to our long partnership with Norilsk Nickel, and we are pleased to have been awarded the contract to modernise their smelting line at Nadezhda. Our unique process expertise and sustainable technologies enable the design and delivery of a world-class smelting process that meets today's and future production requirements," said Jari Ålgars, President of Metso Outotec's Metals business area.

Metso Outotec has also been contracted to deliver a package of process equipment for a greenfield zinc plant at Verkhny Ufaley in Russia's Chelyabinsk region at a cost of approximately €100 million. The order includes an equipment package for zinc concentrate processing, iron precipitation, solution purification and electrowinning technologies for zinc processing based on an OKTOP® reactor, as well as a heat recovery system, ingot casting equipment and high efficiency cooling towers for zinc electrowinning and gypsum removal with reduced emissions compared to conventionally designed cooling towers. It also includes clarifying solutions for solid-liquid separation, high performance filters with low energy consumption, and fully integrated digital process automation for more reliable and flexible operation. ■

BANGLADESH

Ma'aden to supply phosphate to Bangladesh

Ma'aden has renewed its agreement to supply di-ammonium phosphate fertilizer (DAP) to the Bangladesh Agricultural Development Corporation (BADC) throughout 2021. BADC is a state-owned company that works under the umbrella of the Bangladesh Ministry of Agriculture, which manages agricultural imports in the country.

Commenting on the announcement, Ma'aden CEO Mosaed Al Ohali said: "We are pleased to build on our strong partnership with BADC to supply the agricultural industry in Bangladesh with the fertilizer

products local farmers need to make the most of their crops. This new agreement will play an important role in boosting crop output and contributing to stable food supplies in the country. Ma'aden plays an essential role in achieving the goals of Saudi Arabia's Vision 2030 by promoting non-oil exports and sustainable development programs to raise global food security levels. With the natural phosphate deposits in the north of Saudi Arabia and proximity to promising markets in South Asia and East Africa, we are in a strong position to serve the globally growing need for fertilizer products. By 2025, we estimate reaching a production capacity of 9 million t/a of phosphate fertilizers," he continued.

DENMARK

New sulphuric acid catalyst

Haldor Topsoe has launched its new VK38+ sulphuric acid catalyst. VK38+ is potassium-promoted, and the company says it has been proven to have higher activity than any other potassium promoted catalyst on the market, regardless of which converter bed it is used in. There are two installations of the new catalyst, which Topsoe has matched expectations set by laboratory testing. In particular, the higher activity allows the potential for enhanced performance, higher efficiency and reduced climate footprint without the cost increases that are associated with many caesium catalyst solutions. Topsoe claims an up to 40% reduction of long-term catalyst spending and a payback time of just a few months, while different loading combinations and sizes can help meet diverse emission requirements.

WORLD

Copper output falls in 2020

The International Copper Study Group (ICSG) has reported that global copper mine production fell by 1% during the first nine months of 2020, although this fall has not proved to be as sharp as the 3.5% drop in global production recorded during April and May due to the first wave of global coronavirus infections. The global copper market posted an apparent deficit of 387,000 metric tons during the period. Copper concentrate production fell 0.8%, while solvent extraction-electrowinning (SX/EW) production dropped by 1.5%. The world's second largest copper producer, Peru, saw its output fall 16.5% during the first nine months of 2020, on the back of 12.5% year on year falls August and September. Top copper producer Chile, meanwhile, saw its copper production rise in the first half of the year by 2.5%, but Chile's production slipped in Q3 by 3.7%, according to ICSG.

In spite of the drops in copper mine production, refined copper output rose by 1.2% during the first three quarters of the year. Production in the Democratic Republic of the Congo and Zambia increased by 5.5% and 20%, respectively, and Japanese production rose by 5.5%. However, China's output took hits from temporary shutdowns related to Covid-19 restrictions, tight scrap supply and constraints associated with concentrate imports and oversupply in the sulphuric acid market. Elsewhere, Covid-

19 lockdowns from March-May led to a 20% drop in India's refined copper output and US output fell by 14%.

Falling production has led to an increase in copper prices. According to the ICSG, the LME average cash price for copper jumped by 5.4% from October to November, reaching \$7,063/t. The average price for the year of \$6,039/t was an increase of 0.6% from the 2019 average.

UNITED STATES

New MECS sulphuric acid catalyst

DuPont Clean Technologies has introduced two new sulphuric acid catalysts: MECS® Super GEAR™ and XLP-310 which build upon its proven GEAR and XLP catalyst product lines. Super GEAR was specifically developed to minimise total installed cost and achieve world class emissions levels in new plants, while XLP-310 was developed to provide existing plants with an economical option to reduce emissions and boost capacity.

GEAR catalysts have a geometrically optimised hexa-lobe shape that enhances surface area and activity while reducing pressure drop build-up over time. DuPont says that they are also proven to maximise conversion, reduce emissions, and increase time between turnarounds. Super GEAR combines this shape with an advanced formulation which offers sulphuric acid plants the benefits of GEAR while further minimising the total installed cost of new converters.

The XLP ribbed ring catalyst has been in use since 2003 throughout the sulphuric acid industry and is a reliable and economical choice for all converter passes. XLP-310 incorporates an advanced formulation with the XLP shape, for greater activity.

DEMOCRATIC REPUBLIC OF CONGO

New sulphuric acid plant

According to local press reports, Moroccan mining company Managem and its partner Chinese group Wanbao are planning to add a sulphuric acid production line at their Pumpi mine in the DRC. After commissioning delays due to Covid-19, the Pumpi mine began production in September 2020, and at capacity will produce 40,000 t/a of copper and 5,000 t/a of cobalt, according to Wanbao Mining. The project is located in the Kolwezi territory of DRC's Katanga province and contains five deposits of Pumpi Nord, Pumpi Gare,

Pumpi GareSud, Kamassami Simba, and Kamassami Est, with total copper and cobalt resource reserves estimated around 666,000 tonnes and 117,000 tonnes, respectively. Wanbao has a 75% stake in the mine and operating company, Managem Group 20% and the Congolese state the remaining 5%.

ZAMBIA

Legal shenanigans surround KCM

Konkola Copper Mines, 80% owned by London-based Vedanta Resources Ltd, has been in liquidation for most of the past year following allegations by the Zambian government, which owns the remaining 20% of KCM via state mining investment firm ZCCM-IH, that KCM has broken the terms of its license – something denied by KCM and Vedanta. A state-appointed liquidator has been trying to split KCM into two companies - KCM SmelterCo Ltd and Konkola Mineral Resources Ltd – effective from February 2021, and is trying to engineer the sale of KCM SmelterCo Ltd, which owns the company's main asset, the Konkola smelter itself, to Moxico Resources Zambia Ltd, which has been operating the slag dumps at KCM. Vedanta has alleged that this is an attempt at expropriation and asset stripping, and has been in arbitration in London with the Zambian government, which led to a legal block on the breakup and sale of KCM by the Zambian Court of Appeal. However, a Zambian court has now ruled that the liquidator will not be discharged in spite of this prior ruling, and the breakup of the company looks like it will proceed.

CHILE

Chile's considering increase in refined copper capacity

Chile's copper industry is considering an increase in refined copper production capacity rather than maintaining its focus on copper concentrate exports. Although Chile is the world's largest producer of copper concentrate, only around 25% of this is processed domestically. Chile has seven smelters – Chuquicamata, Caletones, Altonorte, Potrerillos, Chagres, Hernán Videla Lira and Ventanas – of which only Chuquicamata, Potrerillos and Ventanas currently have a refinery. Five smelters are controlled by state copper miner Codelco and national mining company Enami, while Altonorte and Chagres are property of

Swiss Glencore and London-based Anglo American, respectively. Chuquicamata is the biggest, with an annual smelting capacity of 1.4 million t/a and refining capacity of 540,000 t/a.

Iván Valenzuela, director of copper studies centre Cesco, says that it believes the smelter sector can be profitable and is a key factor for sustainable mining. Cesco has been working on a proposal to develop a smelting and refinery facility in the country by 2027, suggesting it should be managed by a sector leader. The facility would allow capture of 99% of sulphur dioxide emissions and would achieve a 71% reduction in greenhouse gas emissions compared to the cost of sending concentrate to China. Chile is the world's biggest copper producer, expected to produce 5.82 million t/a this year.

INDONESIA

Feasibility study on HPAL plant

BASF and global mining and metallurgy group Eramet have agreed to a joint feasibility study on the development of a state-of-the-art nickel and cobalt hydrometallurgical refining complex at Weda Bay, Indonesia. The development would include a high-pressure acid leaching (HPAL) plant at Weda Bay and a base metal refinery at a location to be determined during the feasibility study. The project targets a start-up of the HPAL and refinery facilities in the mid-2020s, processing locally secured mining ore from the Weda Bay deposit to produce a nickel and cobalt intermediate. Since its acquisition of Weda Bay in 2007, Eramet has carried out extensive geological work and confirmed the potential of this world-class deposit whose mining operations started at the end of 2019. The project would give BASF access to a secure source of 42,000 t/a of nickel and 5,000 t/a of cobalt from mines operating according to internationally recognised sustainability standards, critical components to support the strong growth in global electric vehicle demand.

The Weda Bay deposit has been under development for several years, and has seen the departure of Mitsubishi, Eramet's original partner, and their replacement by Chinese stainless steel giant Tsingshan in 2017. Following Tsingshan's investment, Eramet owned 43% of the company that controlled Weda Bay, and Tsingshan 57%. Ores have been produced by the joint venture since 2019, and used in a ferronickel plant. ■

CONTENTS

What's in issue 392

COVER FEATURE 1

Sulphur and plant health

COVER FEATURE 2

Canada's sulphur industry

COVER FEATURE 3

New sulphuric acid catalysts

COVER FEATURE 4

The water side of SRUs

SULPHUR
ISSUE 392
JANUARY-FEBRUARY 2021

BCInsight

Southbank House, Black Prince Road
London SE1 7SJ, England

Tel: +44 (0)20 7793 2567

Fax: +44 (0)20 7793 2577

Web: www.bcinsight.com
www.bcinsightsearch.com

People

Corrosion Resistant Alloys, LP, a manufacturer of high-grade corrosion resistant alloy tubes, has appointed **Tom W. Slaughter** in a business development and advisory role. Based in Houston, Slaughter will be responsible for building relationships with strategic partners, including customers and suppliers. Slaughter's background is as an industry leader in high-pressure, high-temperature (HPHT) and deep gas applications with more than 40 years of global industry experience. Most recently, Slaughter served as president of Energy Alloys, Advanced Tubulars beginning in 2007. Prior to this role, he served as president of CRA from 2001 to 2007 where he had full responsibility for global sales and supply chain and worked directly with domestic and international end users of specialty CRA OCTG products.

John Patchell, CRA president, said, "Tom has vast experience in the upstream oil and gas industry, from rig work, to running companies and serving on boards. In his new role with CRA, Tom will mentor, advise, and assist CRA in developing business across the globe and will support us in introducing our unique CRA JIT model to the industry in a manner that can truly bring value to our customers. Tom was an integral part of CRA's early success and we are delighted to have Tom back on board at this critical moment of our industry."

Peter Kirkegaard has been appointed Chief Human Resources Officer of Haldor Topsoe, effective from January 1st, 2021. Since 2016, Peter Kirkegaard has served as executive vice president, chief people & culture officer, with Hempel A/S, which he



Peter Kirkegaard.

joined in 2007 as vice president. Before that, he had a 15 year career with Accenture, where he was a partner leading the Human Performance and Finance & Performance Management sections.

"Peter has shown that he can drive large-scale transformation projects with great results and buy-in from the organisation. I am convinced that his strategic mindset, cultural sensitivity and collaborative approach will bring exceptional value to our company, and that Peter will take an important role in securing Haldor Topsoe's success," said Roeland Baan, CEO of Haldor Topsoe.

"I really look forward to be part of the ambitious transformation that Haldor Topsoe has just begun. The vision to become recognized as the global leader in carbon emission reduction technologies by 2024 truly inspires me. Haldor Topsoe – and its employees – has the potential to do a

remarkable positive difference on a global scale, and I am proud that I can be part of that," Kirkegaard said.

BASF CEO **Dr. Martin Brudemüller** has been elected the new president of Cefic, at the organisation's recent General Assembly. He succeeds Daniel Ferrari, CEO of Versalis (Eni) who held this post from October 2018. Marco Mensink, Cefic's Director General commented: "I am pleased to welcome Martin Brudemüller as our new President. With more than 30 years' experience in various roles in the chemical industry, he will be able to lead us to deliver on the Green deal objectives. Additionally, his strong belief in cooperation with stakeholders will help Cefic to continue to act as a dialogue partner with the European institutions and societal actors."

Martin Brudemüller said: "The EU chemical industry has the capability, know-how and is developing the innovative technologies to deliver on the challenges we are facing today and in the future. The Green Deal is designed as a turning point for Europe and the chemical industry stands ready to support its objectives. The pandemic is one of many instances where we have shown that our sector is resilient and reliable – when we pushed in short time capacity limits to meet the exponential rise in demand for disinfectants, diagnostic tests, ventilators, protective masks and protective clothing. It is my ambition during my presidency that the European Chemical Industry strikes a Future Chemistry Deal in the framework of the Green Deal – where we deliver technologies and solutions and the political framework enables their economical implementation".

Tip the scales with the new VK38+ catalyst

Choosing catalysts is a percentage game. Here's a cheat code.

Choosing sulfuric acid catalysts is about balancing expenses and gains. The new VK38+ not only makes it easier to find the right balance.

Bringing enhanced performance, efficiency and a reduced climate footprint, it tips the scales to your favor.

Calendar 2021

FEBRUARY

1-3

SulGas Conference – **Virtual event**
Contact: Conference Communications Office
Tel: +91 73308 75310
Email: admin@sulgasconference.com

22-25

Laurance Reid Annual Gas Conditioning Conference – **Virtual event**
Contact: Lily Martinez, Program Director
Email: lmartinez@ou.edu
Web: <https://pacs.ou.edu/lrgcc/>

MARCH

1-5

Brimstone Fundamentals of Sulphur Recovery – **Online training course**
Contact: Mike Anderson, Brimstone STS

! The following events may be subject to postponement or cancellation due to the global coronavirus pandemic. Please check the status of individual events with organisers.

Tel: +1 909 597 3249
Email: mike.anderson@brimstone-sts.com

7-9

AFPM Annual Meeting,
SAN ANTONIO, Texas, USA
Contact: American Fuel and Petrochemical Manufacturers (AFPM)
Tel: +1 202 457 0480
Email: meetings@afpm.org
Web: www.afpm.org

22-26

Brimstone Advanced Sulphur Recovery – **Online training course**
Contact: Mike Anderson, Brimstone STS
Tel: +1 909 597 3249
Email: mike.anderson@brimstone-sts.com

23-25

Phosphates 2021 Conference – **Virtual event**

Contact: CRU Events
Tel: +44 20 7903 2444
Email: conferences@crugroup.com

APRIL

19-23

Brimstone Amine Treating and Sour Water Stripping – **Online training course**
Contact: Mike Anderson, Brimstone STS
Tel: +1 909 597 3249
Email: mike.anderson@brimstone-sts.com

MAY

3-7

Brimstone SRU Maintenance and Reliability – **Online training course**
Contact: Mike Anderson, Brimstone STS
Tel: +1 909 597 3249
Email: mike.anderson@brimstone-sts.com



CONTENTS

What's in issue 392

COVER FEATURE 1

Sulphur and plant health

COVER FEATURE 2

Canada's sulphur industry

COVER FEATURE 3

New sulphuric acid catalysts

COVER FEATURE 4

The water side of SRUs

SULPHUR
ISSUE 392
JANUARY-FEBRUARY 2021

BCInsight

Southbank House, Black Prince Road
London SE1 7SJ, England
Tel: +44 (0)20 7793 2567
Fax: +44 (0)20 7793 2577
Web: www.bcinsight.com
www.bcinsightsearch.com

Is sulphur the missing ingredient?

Ron Olson of The Sulphur Institute considers sulphur's important role in plant health.



Fig. 1: Sulphur deficiency in young corn plants four weeks after planting.

Sulphur is demanding more attention these days because the amount provided free of charge, via acid rain and other sources, is becoming less. There have been large changes in the global and regional sulphur dioxide (SO₂) emissions over the last few decades. At the same time, increasing yield trends have increased sulphur removal by the crop. A bushel of corn takes up 0.08 lb (36g) of sulphur in the grain and 0.09 lb (41g) in the stalk or 0.17 lb (77g) total. That means 200 bushels of corn takes up 34 lb/acre of sulphur, or 38 kg/hectare. In terms of actual plant available sulphate (SO₄) that is 102 lbs of SO₄ per acre (114 kg/ha). By understanding the nature of sulphur and its role in plant growth, farmers around the world can ensure their crops are never starved for this essential nutrient.

Characterised by its bright yellow colour, sulphur can take many forms or oxidation

states; elemental sulphur ions, mineral sulphate or sulphide gas. This is unique to sulphur, for example potassium always remains a potassium ion as it passes through soil microbes and plants. Soil microbes are essential for converting organic sulphur (not available to the plant) into sulphate which is available to the plants. Ninety-five percent of all sulphur found in the soil is tied up in its organic matter.

Sulphur's role in plants

Plant dry matter contains 0.2-0.5% sulphur (about the same percentage as phosphorus). In crop production, sulphur's most critical job is helping produce protein molecules and amino acids, which are required to produce chlorophyll, lignin, and pectin. To do that, it assists in photosynthesis, the process in which plants convert sunlight into chemical energy.

In one aspect of protein production, sulphur helps metabolise nitrogen. If a plant tissue test reveals a sulphur deficiency, it probably will show a nitrogen deficiency too. Both are structure-building components, so sulphur (like nitrogen) is required early in the season. The plant needs sulphur to build the factory that will produce the seed or fruit.

Besides showing a pale green colour, sulphur deficiency results in stunted growth. Anything that retards growth delays maturity. Sulphur-deficient corn will delay tasselling and pollination and matures

later. Plants become inefficient, producing less growth per day. Below the ground, sulphur deficiency shows up in a slow-growing, smaller, inefficient root system.

The pale green colouration, stunted growth and delayed maturity mimic the symptoms of nitrogen deficiency. The main difference is that nitrogen deficiency shows up in the bottom leaves of the plant, but sulphur deficiency shows up in the newer growth; the top leaves or whorl. Unlike nitrogen, sulphur is not mobile in the plant, so the plant cannot mobilise sulphur from older portions and move it to newer ones.

Figure 2 shows young corn plants growing with and without sulphur. On the left the plants are growing well, showing good green colour and vigour. On the right the plants are a pale green colour, lacking vigour – the health of these plants has been significantly impacted by the lack of sulphur. In this example the lack of sulphur is slowing down photosynthesis and root development. NPK fertilizer application was the same for both plots. Only sulphur was missing.

Figure 3 shows a wheat crop on the left severely impacted by the lack of sulphur. Again the NPK fertilizer application was the same for both plots. Only sulphur was missing, resulting in reduced photosynthesis and delayed and reduced plant development.

Figure 4 shows corn and soybean sulphur usage. A corn plant uses 52% of all seasonal sulphur needs post-tassel. A soybean plant uses over 85% of all season sulphur

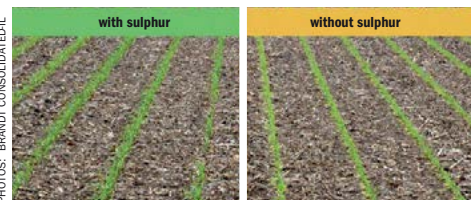

Fig. 2: Young corn plants growing with and without sulphur.

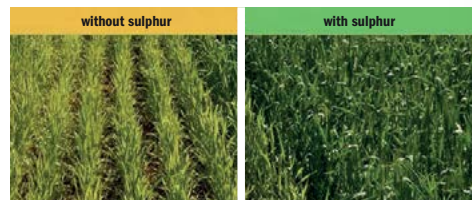
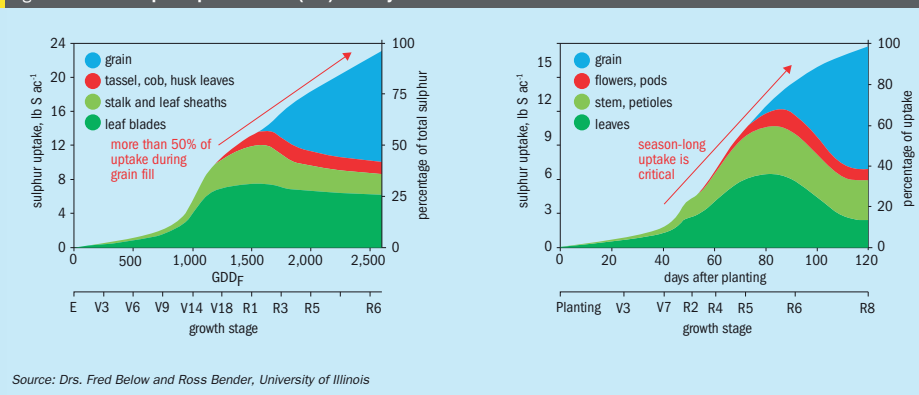

Fig. 3: Wheat crop showing the impact of sulphur deficiency.

Fig. 4: Seasonal sulphur uptake in corn (left) and soybeans



Source: Drs. Fred Below and Ross Bender, University of Illinois

Fig. 5: The sulphur cycle

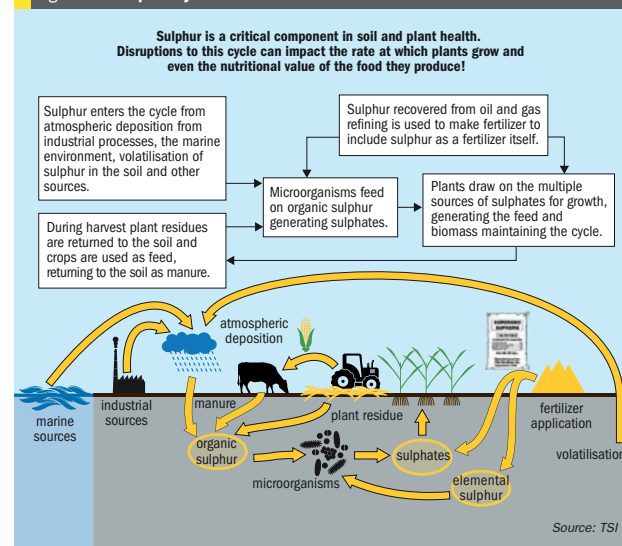

phur needs during its reproductive stages. This confirms that corn and soybeans need a full season supply of sulphur to meet the crop's needs during critical growth periods.

Sulphur uptake

Aside from a small amount of sulphur in rainfall, or foliar feeding of sulphur fertilizer, the main form of sulphur that plants can take up is sulphate. The large amounts

of sulphur needed to produce crops must be taken up by the root system in order to meet the plant's needs. The amount of sulphur consumed by the plant depends on how much of the nutrient the roots contact as they grow through the soil. In the soil, sulphate moves toward the roots by diffusion and mass flow. In diffusion, sulphate moves from a more concentrated area to a less concentrated area – similar to food colour dispersing in water.

In mass flow, water containing sulphate is pulled to the plant roots. Transpiration through the plant draws more water out of the soil, bringing sulphate with it.

The sulphur cycle

In the soil, there are three forms of sulphur: sulphide gas, sulphide minerals and elemental sulphur, which need to be oxidised into sulphate for plants to use. All of these sources go through oxidation. Like nitrogen and phosphorus, sulphur follows a cycle in which it moves from the organic form, which plants cannot use, to the inorganic form, which they can take up and return again.

Some microbes and plants immobilise sulphur; others mineralise (or oxidise) it into sulphate. Mineralisation and immobilisation go on at the same time. The sulphur cycle is shown in Figure 5: it shows how sulphur gets to the crop; the forms of sulphur and what happens to the sulphur, like plant uptake, leaching and volatilisation. It is key to note that sulphur is lost from the soil in much the same way as nitrogen is. Sulphur is absorbed as the sulphate ion and can also enter plants as sulphur dioxide gas. Sulphur comes into soil solution via the mineralisation of organic matter. Low organic matter soil can be deficient, as 95% of sulphur found in the soil is tied up in the organic matter. Each 1% of organic matter can supply 3-5 lbs/1.4-2.3 kg of sulphur via mineralisation.

Sulphur deficiencies in soils are increasing and sulphur fertilizer has become more important because higher

CONTENTS

What's in issue 392

COVER FEATURE 1

Sulphur and plant health

COVER FEATURE 2

Canada's sulphur industry

COVER FEATURE 3

New sulphuric acid catalysts

COVER FEATURE 4

The water side of SRUs

SULPHUR
ISSUE 392
JANUARY-FEBRUARY 2021

BCInsight

Southbank House, Black Prince Road
London SE1 7SJ, England

Tel: +44 (0)20 7793 2567

Fax: +44 (0)20 7793 2577

Web: www.bcinsight.com
www.bcinsightsearch.com

Fig. 6: Sulphate ion wet deposition, 1986 (left) compared to 2016 (right)

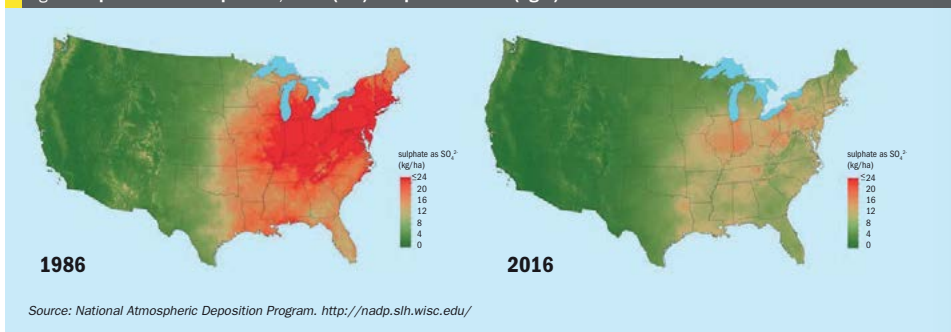

Source: National Atmospheric Deposition Program. <http://nadp.slh.wisc.edu/>

crop yields are removing more sulphur. At the same time, crops are receiving less sulphur from the air due to the decreased use of high sulphur coal and removal of sulphur dioxide from stack gases (up to 25-30 lbs/acre or 25-35 kg/hectare of sulphur used to be deposited free in industrialised countries via acid rain). Figure 6 shows the sulphate ion wet deposition in the US for 1986 being greater than 25 kg/ha compared to 4-8 kg/ha in 2016. This is an 80%+ reduction in sulphate ion deposition and is similar to reductions in Europe and other parts of the globe.

Sulphur as a nutrient

Important factors to remember about sulphur as an essential plant nutrient include:

- Sulphur deficiencies are more common due to higher yields and less sulphur dioxide gases being emitted from stacks.
- Sulphate (SO₄) is highly mobile in the soil and can leach like nitrogen.
- Most soils typically cannot supply adequate sulphur nutrition through mineralisation.
- Low mineralisation growing seasons (cooler and wetter than normal) can increase sulphur deficiency.
- Corn takes up 52% of its sulphate needs after tasselling and pollination and soybeans take up 85% of its sulphate needs during flowering and pod fill.
- There is a strong relationship between nitrogen and sulphur since both are associated with chlorophyll formation and both are constituents of proteins.

Approximately 54% of all recovered sulphur produced globally is used in agri-

cultural fertilizer production to produce food to feed a hungry world. The science of sulphur has not changed. Sulphur will continue to be an essential plant nutrient supporting the changes coming from the Internet of Things, digitalisation of agriculture, machine learning, artificial intelligence, and big data. Here are nine areas that represent some of these trends:

1. Smart fertilizers were listed as number 5 out of the Top 10 Emerging Technologies at the 2019 World Economic Forum.
2. The global implementation of the 4R Nutrient Stewardship Principles: Right Product, Right Rate, Right Time, Right Place.
3. Emerging landscape of biostimulant/biological products
4. Soil health, cover crops, reduced tillage, and regenerative agriculture
5. Biotechnology – as new hybrids and varieties that can deliver higher protein content sulphur will matter and play a key role
6. Sulphur-enhanced fertilizers and direct application of sulphuric acid (H₂SO₄)
7. Precision agriculture tools that will create algorithms to deliver targeted fertilizer applications down to many sub-fields within a field that will drive yields, efficiency, profitability, and sustainability.
8. Nanotechnology to make fertilizers more efficient
9. Greater use of robots in agriculture

As we study these trends, TSI is going to examine how sulphur impacts or is impacted by each one. The need for sulphur by global crop production is significant and looks to create positive benefits for the Sulphur industry. The Sulphur Institute is well positioned to help its members move into this exciting future. ■

References

1. Aas, W., Mortier, A., Bowersox, V. et al. Global and regional trends of atmospheric sulfur. *Sci Rep* 9, 953 (2019). <https://doi.org/10.1038/s41598-018-37304-0>
2. Bender, R. R., Haegele, J. W., Ruffo, M. L., & Below, F. E. (2013). Modern corn hybrids' nutrient uptake patterns. *Better Crops*, 97 (1), 7-10. [http://www.ipni.net/publication/bettercrops.nsf/0/926946F50406A54085257B18005BB7AA/\\$FILE/page 7. pdf](http://www.ipni.net/publication/bettercrops.nsf/0/926946F50406A54085257B18005BB7AA/$FILE/page%207.pdf)
3. Haegele, J. (2020, April 10). Which nutrient does your soybean crop crave? Retrieved December 23, 2020, from <https://www.ilssoyadvisor.com/on-farm/ilssoyadvisor/which-nutrient-does-your-soybean-crop-crave>
4. National Atmospheric Deposition Program. Retrieved from <http://nadp.slh.wisc.edu/>
5. Pagani, A., Sawyer, J., Mallarino, A. (2020). Chapter 5: Sulfur management. In 4R educational modules: Site specific nutrient management. Online course. Retrieved December 23, 2020, from <https://nutrient-stewardship.org/training/>
6. Set your spring up for success: Start with sulfur. Retrieved December 23, 2020, from <https://www.goldenharvestseeds.com/agronomy/articles/set-your-spring-up-for-success-start-with-sulfur>
7. Stewart, W.M. (2010). Sulfur – the 4th major nutrient. *IPNI Plant Nutrition Today*, 7. [http://www.ipni.net/publication/pnt-na.nsf/0/34FF4E39D598B6AF85257CD6005A0FD/\\$FILE/PNT-2010-Summer-ALL.pdf](http://www.ipni.net/publication/pnt-na.nsf/0/34FF4E39D598B6AF85257CD6005A0FD/$FILE/PNT-2010-Summer-ALL.pdf)
8. Top 10 Emerging Technologies 2019. (2019, July 2). Retrieved December 23, 2020, from <https://www.weforum.org/reports/top-10-emerging-technologies-2019>

MOLTEN SULPHUR FILTER

Advantages

- Quick opening and closing by hydraulic
- Full jacketed design of vessel
- 5 layer bolted leaf design can handle high pressure
- Large leaf spacing allows higher thickness of cake build up and permits easy cleaning
- Overhead frame design can be offered
- Scrapper plates are provided to remove the residual molten sulphur from the inside of vessel
- More than 50 installations

Sharplex have supplied several filters for molten sulphur filtration in sulphuric acid & sulphonation plants. Sharplex offers horizontal pressure leaf filter for molten sulphur filtration in Shell retraction design and Bundle retraction design.

Both the versions are operated (for opening and closing of filter) hydraulically for easy of operation.

FILTRATION AREA
From 5 m² to 200 m²

FOR EFFECTIVE SULPHUR FILTRATION

CARTRIDGE FILTERS FOR SULPHUR POLISHING



Cartridge type polishing filters are installed after main molten sulphur filters to remove traces of fine suspended particles ash and filteraids escaped from main filter, which may choke the downstream equipments in the plant. The removal of these fine solids will help in running the downstream equipments smooth without interruptions. This will result in reducing the downtime of the plant to great extent.

SHARPLEX FILTERS (INDIA) PVT. LTD.
R-664, T.T.C. Industrial Area, Thane-Belapur Road, Rabale, MIDC, Navi Mumbai - 400701, India; Tel : +91-91-3692 1232/39, +91-22-27696339/6322/6325. E-mail : sales@sharplexfilters.com
Website : www.sharplex.com

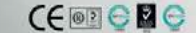

signature@vivalpi0919



CONTENTS

What's in issue 392

COVER FEATURE 1

Sulphur and plant health

COVER FEATURE 2

Canada's sulphur industry

COVER FEATURE 3

New sulphuric acid catalysts

COVER FEATURE 4

The water side of SRUs

SULPHUR
ISSUE 392
JANUARY-FEBRUARY 2021

BCInsight

Southbank House, Black Prince Road
London SE1 7SJ, England
Tel: +44 (0)20 7793 2567
Fax: +44 (0)20 7793 2577
Web: www.bcinsight.com
www.bcinsightsearch.com

Canadian sulphur



PHOTO: VANCOUVER WHARVES

After many years of slow decline, Canadian sulphur exports have begun to rise slightly, but dwindling US markets are seeing a move towards more sulphur forming to expand export opportunities.

Canada continues to be one of the world's largest exporters of elemental sulphur and a major player in the sulphur arena. Although the history of the past two decades has been one of slow decline from the dominant market position it once enjoyed, rising oil sands upgrading and a stabilisation of output from sour gas plants are leading to higher sulphur production once more.

Canada's elemental sulphur production has three main components; refining, mainly in the east of the country; sour gas processing, mainly in the provinces of Alberta and British Columbia in western Canada; and production from processing and upgrading of oil sands bitumen, almost exclusively in northern Alberta.

Oil refining

Canada is the world's fourth largest oil producer, averaging 4.8 million barrels per day in 2019, representing 5.9 % of global oil production, and its reserves, at least if the oil sands patch is included (representing as it does 97% of Canada's oil/oil equivalent reserves), are the third largest in the world at 170 billion barrels, representing 10% of the world's oil reserves. Canadian oil production has been on a steadily rising trend for many years, climbing from 2.1 million bbl/d of production in 2000 to its present figure.

Oil/oil equivalent production is split into two main areas – conventional oil production and oil sands mining and processing. As well as these, there is potential for tight and shale oil production in Canada in much the same way that the US has developed its tight oil industry, but as yet this remains largely untapped in Canada. Oil sands output has formed the main increase in Canadian oil production over that time, overtaking conventional oil production in 2010. Conventional oil production, mostly from fields

in Alberta and Saskatchewan, as well as some offshore production from Labrador and Newfoundland in the east, has been relatively flat for the past decade, dipping from 1.8 million bbl/d to 1.5 million bbl/d from 2014-17, then recovering to around 1.7 million bbl/d. The coronavirus pandemic hit Canadian production hard, particularly output from the oil sands, because of the contraction in global demand and resulting low prices, and overall oil production dropped by about 20% over the first half of 2020. However, it began to rebound from about September onwards, and by the end of 2020 was almost back to normal.

Canadian demand for oil is about 1.7 million bbl/d, to feed its refining sector, which provides a net 90% of Canada's demand for refined products (the rest is imported from the US, though some product also goes the other way). With production outstripping demand by over 3 million bbl/d, most of the oil, especially from the oil sands patch, is exported, mainly across the border south to the United States. A total of 3.8 million bbl/d of oil was exported in 2019, but a further 0.8 million bbl/d was imported, mainly into eastern Canada from the northeastern US, for a net 3 million bbl/d of exports.

Downstream, Canada's domestic refining capacity is relatively small; there are 15 refineries operational in Canada (including two bitumen refineries), as shown in Table 1, with a total capacity of 1.9 million barrels per day, and an average utilisation of 89% in 2019. Refinery capacity is concentrated in the east of the country, especially Ontario, Quebec and the Atlantic coast (Labrador, Newfoundland, New Brunswick). These provinces between them operate 1.24 million bbl/d of capacity, or about two thirds of the total, 390 million bbl/d of this in Ontario. There are also some small refineries in Saskatchewan and British Columbia. In Alberta, meanwhile, much of the refinery capacity is geared at processing oil sands crude. Aside from the oil sands, described further below, 'conventional' oil refining in Canada produces about 600,000 t/a of sulphur, most of it in Ontario and Quebec.

Oil sands processing

Of increasing importance to the Canadian oil and refining industries is the exploitation of oil sands bitumen. The mines are concentrated in northern Alberta and are of two types: conventional, open pit mines, and in situ production, the latter of which pumps steam down into underground deposits to melt the bitumen and then draws it back out. This so-called steam assisted gravity drainage (SAGD) method is increasingly popular as it is not only cheaper but uses less water and avoids the large scale scarring of the landscape of open pit mining, which must then be remediated. The bitumen is either upgraded to produce synthetic crude oil

('syncrude'), or diluted with lighter fractions such as naphtha to produce a 'dilbit' (dilute bitumen) or with syncrude to create a 'syn-bit'. These are light enough to be pumped, and so can be exported by pipeline or rail.

Oil sands production has roughly doubled over the past decade, with seven major mining projects in Alberta responsible for approximately 60% of that production, including Syncrude (354,000 bbl/d), Suncor (290,000 bbl/d), CNRL's Horizon Mine (234,000 bbl/d), Imperial's Kearn mine (280,000 bbl/d), Fort Hills (164,000 bbl/d) and the Athabasca Oil Sands Project at Muskeg River (159,000 bbl/d) and Jackpine (130,000 bbl/d). Overall oil sands production totalled 2.9 million bbl/d in 2019.

As noted previously the rapid contraction in global oil demand and hence prices caused by the coronavirus pandemic led to major problems for Canadian oil sands producers, who shut in almost 1 million bbl/d of production around May-June 2020, and leading Cenovus to buy out rival Husky Energy. Production costs for oil sands producers tend to be among the highest of Canadian oil operations. However, breakeven costs of oil sands production are falling, and as global oil prices rebounded later in 2020, so did oil sands production. The Alberta Energy Regulator said that in November 2020 oil sands production hit a record 3.16 million bbl/d. And subsequent to that, the Alberta provincial government removed production curtailments, which had been introduced in 2019 to ease congestion on export pipelines. Output could rise to 3.3 million bbl/d by the end of 2021, and syncrude production is forecast to rise to 3.8 million bbl/d by 2030.

As oil sands are sulphur rich (about 4-5% by weight), where this production is processed is of vital importance to the sulphur industry. Currently, most (55%) Canadian oil sands production is exported directly to the US, by rail or pipeline, without being upgraded. However, bottlenecks in cross-border transit capacity have been exacerbated by long-running disputes over export pipelines like Keystone XL. This constraint looks set to ease however, as around 500,000 bbl/d of new rail and pipeline capacity is expected to come on-stream over the next 1-2 years. In the meantime, Alberta oil sands upgrading capacity has been slowly rising, reaching just under 1.5 million bbl/d in 2020 with the startup of the 50,000 bbl/d Scotford expansion.

Oil sands processing in Alberta generated about 2.5 million t/a of sulphur in 2019. Projections from the data released

so far by the Alberta Energy Regulator (for the eleven months to November 2020) indicate that the overall full year 2020 figure is likely to be very similar.

Sour gas

North American sour gas production is mainly concentrated in western Canada, in particular the Western Canadian Sedimentary Basin (WCSB), which extends from Saskatchewan across northern Alberta and British Columbia and up into the Northwest Territories. Sour gas exploitation was pioneered in Western Canada, and sulphur production began at Jumping Pound, Alberta in 1951.

Most of Canada's sour gas boom is well and truly over now, with sour gas wells declining and most new production coming from unconventional (shale gas) production. Nevertheless, after a long decline from 2001, Canadian sour gas production has now stabilised, and sulphur recovery from sour gas processing was 1.5 million t/a in Alberta in 2019, and 250,000 t/a from British Columbia. Figures for 2020 indicate that full year Alberta sour gas sulphur production will again be 1.5 million t/a.

Sulphur markets

Domestic demand for sulphur in Canada is relatively low, totalling about 800,000 t/a. While the country is a major producer of potash, it has never really developed the phosphate mining industry that its larger neighbour to the south has, and there is only one phosphoric acid plant remaining operational, at Redwood, Alberta. There have been some project proposals – Ariane Phosphates has for some years been developing a phosphate mine and beneficiation complex at Lac à Paul in Quebec, which would produce 3 million t/a of phosphate concentrate at capacity. A bankable feasibility study, permits and offtake agreements are in place, but there is still as yet not a firm date for construction to begin, and the company spent 2020 improving the efficiency of its metallurgical process and discussing financing arrangements. Ariane is also considering a 500,000 t/a phosphoric acid plant at Belledune in New Brunswick, using steam and fresh water from a nearby power plant and sulphuric acid from Glencore's Brunswick lead smelter to process 1.4 million t/a of the phosphate concentrate from the mine. Around 1.5 million t/a of sulphuric acid will be required, probably leading to imports of sulphuric acid to the side in addition to acid from the smelter.

Exports

For the moment, however, Canada's sulphur surplus must be largely exported. Canadian sulphur production was about 4.8 million t/a in 2019, with about 1.7 million t/a coming from sour gas processing and 2.5 million t/a from oil sands upgrading, plus 0.6 million t/a from conventional refining. Canadian domestic consumption runs at about 0.8 million t/a, leading to a surplus of 4.0 million t/a, most of which is exported. In 2019, around 1.5 million t/a was exported south to the US, mainly as molten sulphur, while 2.5 million t/a was exported via Vancouver port. Full year figures for 2020 are not yet compiled, but Vancouver exports to June were 1.4 million t/a, up 6% on 1H 2019.

Generally Canada has exported molten sulphur south to the US market for phosphate production; around 1.5 million t/a in 2019. Figures to October 2020 were 1.2 million tonnes, up 8% on the 10 month figure for 2019. However, this increase masks a change in US sulphur consumption. As the US phosphate industry has shrunk over the past decade, so demand for Canadian sulphur has fallen. Long distances and high transit costs have led Mosaic to install a 1.0 million t/a sulphur melter at New Wales in Florida so that it can import dry bulk sulphur instead.

This in turn has pushed Canada towards more sulphur forming projects. The largest in recent years has been the Heartland Sulphur project at Strathcona near Edmonton, Alberta, which came onstream in 2017 with a capacity of 650,000 t/a of wet prilled sulphur, but this was expanded to 1.3 million t/a with the addition of a second line in October 2020. Other new projects are now also lining up. H.J. Baker, which bought Oxbow Sulphur Group in 2019, has inherited the Alberta Forming Project at Kinosis near Fort MacMurray, intended to process up to 4,000 t/d (1.3 million t/a) of sulphur from nearby oil sands producers. Keyera and Enbridge are looking at a similar sized terminal just to the north at South Cheecham, with a provisional date of 2022. Sulphur Midstream is also reportedly looking at a 2,000 t/d prilling plant, while back in 2009 Hazco also received approval for a 1 million t/a forming project at Bruderheim near Edmonton, though the project was not carried out at the time.

Whether Alberta needs so much forming capacity is a rather more vexed question, even if the 11 million tonne stockpile at Syncrude and elsewhere at Fort MacMurray were to be melted down for sale. ■

Table 1: Canadian refinery capacity, 2019

Province	Number of refineries	Total capacity ('000 bbl/d)
Alberta	4	509
British Columbia	2	67
New Brunswick	1	318
Newfoundland/Labrador	1	130
Ontario	4	392
Quebec	2	402
Saskatchewan	1	130
Total	15	1,948

Source: Canadian Fuels Association

Sulphur + Sulphuric Acid 2020

The coronavirus outbreak necessitated a 'virtual' CRU Sulphur + Sulphuric Acid conference last year, held in November 2020.

Disappointing as it was not to be able to visit the attractive Dutch city of The Hague, CRU's virtual conference application offered a palatable alternative, and certainly made the travel costs lower. The app was a slicker one than I have seen for some other virtual conferences, and offered some networking opportunities via virtual exhibition stands and chat windows, while the conference sessions were presented live, with opportunities for questions and answers. It's not a full substitute for the real thing, but it is unfortunately something that we are all going to have to live with for a few more months at the very least.

Markets

Peter Harrison presented the usual sulphur market overview. Supply had been abundant going into 2020, he said, with IMO regulations helping boost refinery output, but as the pandemic hit, Q2 saw major refinery cutbacks, leading to 20-40% cuts in production rates. Although these had recovered, refinery sulphur output was still down 10-20%. This led to increasing tightness in supply and demand in Q3 moving into Q4 2020, with prices climbing. The question was where the ceiling might be. Peter suggested that Chinese stocks (currently around 3 million tonnes) are becoming active as prices reach \$90-95/t, and this might help stabilise prices.

On the phosphate side, 2020 had seen a small fall in demand, but demand growth was likely to return in 2021, to the tune of another 1.5 million t/a of sulphur. Likewise industrial demand was down last year, but should return to growth in 2021.

However, while 2021 will see an increase in sulphur supply on 2020, overall supply is likely to still be down on 2019. China is commissioning new capacity in both

oil and gas processing, while the US has seen 400-600,000 t/a lost from refinery cutbacks. There is likely to be a global production rebound from new projects in 2021, especially in the Middle East, but demand growth will average above supply growth, narrowing market oversupply, and possibly leading to some tightness to remain in molten sulphur markets. Out to 2024-5, however, the new project pipeline becomes much smaller, while increased metals demand, especially for nickel leaching, will start to kick in from 2023. Looking to the longer term, lithium mining will also provide more demand.

Brendan Daly followed with an overview of the sulphuric acid market. Prices were weak in 2019 and this continued in 2020, leading to some very low points in April, even going negative in some markets. Prices have recovered somewhat since then but remain subdued. Imported volumes into markets such as India and Chile were 300,000 tonnes down on the previous year in Q2, but up in Q1 and Q3. Export acid volumes had increased, but at a slower rate, and declined in Q3 as Chinese internal market demand rebounded, leading to less Chinese export availability. Chilean demand remains weak, with imports down to 2.7 million t/a for 2020, compared to 3.5 million t/a in 2019. Chilean copper-based acid demand is likely to recover in 2021, Brendan said, but over the period 2021-25, closures will roughly match expansions, and imports will fall to 1.8 million t/a by 2024. Peruvian availability meanwhile will decline due to an increase in domestic consumption, with Peru's exports falling to 1.0 million t/a.

Elsewhere, India's Tuticorin smelter is unlikely to return to production. Moroccan demand is growing rapidly, but acid imports are projected to fall as more sulphur burning acid capacity is built.

Morocco absorbed much of this year's surplus because acid was so cheap, but may not do so in future.

US offshore imports have climbed as local availability drops due to outages. Demand prospects are stronger from 2021, though smelter supply is also strengthening, and imports should thus remain relatively flat.

Finally, Chris Lawson offered a perspective on the phosphate market. There has been strong Chinese demand for soybeans and corn, but domestic phosphate production was disrupted by the Covid-19 outbreak – Hubei Province is a centre of the Chinese phosphate industry. In general, agricultural markets have been relatively resilient to the coronavirus outbreak compared to many others, and so demand has held up, with particular strength in Brazil and the US, and some increase in Russia and Australia, though it has fallen in China and Africa.

Sulphur technology

In the sulphur sessions, Attila Racz of Jacobs Comprimo looked at how oxygen enrichment of a sulphur recovery unit can feed into design optimisation considerations, via a case study of an existing unit that was revamped to a much higher capacity. Amine regeneration and the sour water stripper units were also debottlenecked as part of the revamp.

Jenna Dalhman of Nesta and Bernhard Schreiner of Linde also talked oxygen enrichment, but this time extending low level (28%) enrichment to low load operation at Neste's Naantali refinery in Finland.

Exxon, BASF and Fluor, the latter in the form of Thomas Chow, also presented on oxygen enrichment, with a case study on COPE oxygen enrichment and a description of Fluor's new OEC2RP or oxygen

enhanced Claus carbon dioxide recovery process.

Siirtec Nigi have developed a technology called *SplitOxy* which, as the name suggests, splits the oxygen addition, feeding it both at the Claus burner as well as into the rear channel of the waste heat boiler, creating a second reaction chamber (as the gas is above auto-ignition temperature) which can be varied without affecting the main process burner. An installation in Colombia in 2020, complicated of course by Covid, has increased capacity by 80%.

Elsewhere in the Claus process, Sandeep Sutar of Saudi Aramco looked at enhancing SRU efficiency through predictive monitoring, part of the way data driven approaches are enhancing operating efficiency these days, including monitoring of feed quality, amine and acid gas distribution monitoring, to prevent hydrocarbon and ammonia carryover. Meanwhile, temperature measurement challenges in a Claus reactor was the subject for Deniz Keles of Thermometrics, showcasing a range of measurement probes to help ensure safe and efficient operation.

Moving downstream, Lorraine Huchler of Martec and consultant Elmo Nasato focused on the water side of sulphur recovery units, and avoiding water-related failures in the waste heat boiler and condensers, especially when revamps have focused on increasing capacity, pressure and temperature, via a more holistic design approach. Nathan Hatcher and Simon Weiland of Optimized Gas Treating also presented a case study of sulphidation corrosion in a Claus waste heat boiler.

Gerald Bohme of Sulphur Experts looked at pre-sulphiding of tail gas treatment unit catalyst, and how to handle it, with due caution as to self-heating when interacting with oxygen and managing temperature rise, potential H₂S breakthrough, and other considerations.

David Inward, of the memorably named Sick AG, presented a hot, wet extractive infrared analyser for measuring emissions from the final stack of an SRU, to ensure that it remained within compliance of local air quality limits.

Finally, Inshan Mohammed of Sulphur Recovery Engineering reported on a troubleshooting assignment for accelerated corrosion within the regenerator column of an acid gas enrichment unit. Cracking was found in welds using ultrasonic measurement, but the conclusion was that this was not accelerated – previous visual and non-



NORAM acid tower installation at a Codelco plant in Chile.

destructive testing inspections had simply failed to identify it.

Sulphuric acid technology

As usual, running in parallel with the sulphur technology sessions were two sessions on sulphuric acid technology. Plant design and construction was a fertile topic for some of the major licensors. Outotec presented on the importance of the gas cleaning section of a metallurgical sulphuric acid plant as ore feeds decline, leading to higher impurity levels which, if not tackled through enhanced scrubbing/electrostatic precipitation techniques etc, will impact upon the longevity of the downstream acid plant. They also presented a second paper which looked at the coronavirus pandemic, and how it had necessitated a much greater reliance for operators on online support from licensors and constructors, and the digital tools which can be used to deal with this. On a related topic, Boris Pickering of Chemetics discussed capital spends, and how to minimise them when designing one of the current generation of 'mega' acid plants.

From the theoretical to the practical; Andres Mahecha-Bohero of NORAM Engineering compared and contrasted two case studies of designing acid tower replacement systems; an acid tower replacement for a sulphur burning plant in North America, which used an all metal alloy tower, and a replacement at a copper smelter in South America, where a brick-lined carbon steel tower was used. Michael

Baerends of Fluor meanwhile explored the commissioning and start-up of a wet gas sulphuric acid (WSA) plant, and the teething troubles encountered, including stack analyser issues, and heavy misting in the condenser.

Revamping always offers issues, but in particular when it is a revival of a 30-year old plant. Ayman El Hafeiz of AZFC in Egypt was tasked with this, and described how via collaboration with DuPont-MECS the plant was brought back into service.

On the subject of catalysts, Marten Granroth of Haldor Topsoe and Tom Brubbers of DuPont MECS both presented their companies new grades of sulphuric acid catalyst – VK-38 for Topsoe and XLP-310 for MECS respectively. Much more information on both of these can be found in our article on pages 28-35.

The topic of mist eliminators brought two papers. Alessandro Gulla of AWS described GX – a new gas-liquid coalescing filter medium, and experiments carried out at laboratory and pilot plant scale to determine the best formulation for it in terms of separation efficiency and pressure drop. GX candles now offer 100% separation efficiency for droplets larger than three microns, and 99% efficiency for sub-3 micron particles. Ali Goudarzi of CECO, meanwhile discussed a candle filter retrofit to meet more stringent NOx emissions.

Corrosion, another perennial topic for acid plants, was covered by Michael Davis of the Nickel Institute, who looked at the use of nickel alloys in the highly corrosive environment of a sulphuric acid plant, while James Cook and Keith Robinson of AirBTU explored the issue of sub-dewpoint corrosion, and how temperature mapping and computational fluid dynamics can be used to identify areas of a heat exchanger that might be subject to such corrosion, and design to minimise them.

The final two papers covered spent acid recovery, where Martin Joksich of P&P presented his company's acid concentration unit, and Victor Machida of Clark Solutions described a small (150 t/d) modular sulphuric acid plant designed for the Kalium project in Brazil which processes glauconite ore with sulphuric acid, combining sulphur burning and metallurgical acid sections of the process, to generate potassium and magnesium sulphate, and aluminium and iron oxides. The plant is a single absorption unit with tail gas scrubbing and a novel heat recovery section using an intermediary fluid.

CONTENTS

What's in issue 392

COVER FEATURE 1

Sulphur and plant health

COVER FEATURE 2

Canada's sulphur industry

COVER FEATURE 3

New sulphuric acid catalysts

COVER FEATURE 4

The water side of SRUs

SULPHUR
ISSUE 392
JANUARY-FEBRUARY 2021

BCInsight

Southbank House, Black Prince Road
London SE1 7SJ, England

Tel: +44 (0)20 7793 2567

Fax: +44 (0)20 7793 2577

Web: www.bcinsight.com
www.bcinsightsearch.com

China's phosphate industry

Continuing rationalisation in China's phosphate industry has been reducing demand for sulphur and sulphuric acid at the same time that the country is producing more of both.

China's phosphate industry has come to be one of the defining features of the global sulphur industry. The rapid expansion in Chinese phosphate capacity in the period 2000-2015, especially of mono- and di-ammonium phosphate capacity (MAP/DAP) initially began as in import replacement policy, but capacity building continued long after self-sufficiency was reached, and turned China from a net importer into a net exporter of phosphates, with India an increasingly important customer.

China has large reserves of phosphates – the second largest in the world – and was able to produce ammonia by coal gasification to draw upon large domestic reserves of coal. However, generating enough sulphuric acid to process the large volumes of phosphate rock was more than China's metallurgical and pyrite-roasting acid capacity was able to supply. With domestic sulphur production relatively low, the net result was rising imports of sulphur to China to feed sulphur burning acid capacity.

Chinese phosphoric acid production rose from 10.9 million t/a P_2O_5 in 2008 to 18.8 million t/a P_2O_5 in 2015. This was mostly due to a doubling of MAP and DAP production over that period, from 3.7 to 7.2 million t/a P_2O_5 in the case of MAP, and from 3.8 million t/a to 8.1 million t/a P_2O_5 in the case of DAP, as shown in Figure 1.

However, since then there has been a slow but steady decline, especially in DAP production.

The major reasons for this are twofold; the government has tried to make Chinese use of phosphate more efficient, and to cap fertilizer consumption at its 2020 level. Chinese DAP consumption peaked in 2013 at 5.6 million t/a P_2O_5 , but since then has fallen to 3.7 in 2019. MAP consumption reached 6.2 million t/a P_2O_5 in 2016, but fell to 5.7 million t/a in 2019. Falling domestic consumption

means that producers are more reliant on finding export markets for their product, and increasing supply and competition has been making that more difficult. Apart from a rally during 2018, DAP prices have been on a slide since 2014, dropping from \$500/t to around \$270/t f.o.b. the US Gulf in late 2019, some way below the average Chinese cost of production, which is just over \$300/t.

Side by side with this has been a crackdown by the Chinese government on polluting industries and increasing environ-

mental legislation. Much of the excess or unproductive capacity has been forced to close over the past few years, especially in the Yangtze River basin, where much of China's phosphate capacity is concentrated. In 2015-17, about 1.8 million t/a of DAP capacity and 2.5 million t/a of MAP capacity (both in terms of tonnes product) was idled, most of it from smaller scale producers.

Chinese phosphate rock mining has also been falling as costs of production rise, and the country may become a net phosphate rock importer by 2023.

After the pandemic

The coronavirus pandemic was another challenge for the Chinese phosphate industry. Hubei province, where the outbreak began and was at its worst, is the centre of the Chinese phosphate industry, with 28% of the country's production capacity. Closures dropped the fertilizer industry utilisation rate by 30-40% during 2Q 2020. Chinese DAP production was down by 12% in 1H 2020 compared to 2019, and MAP production was down 7%. Chinese DAP exports dropped 26% over the same period. However, the closures did remove a lot of the overcapacity in the international phosphate market, and led to prices heading back upwards from the middle of the year.

Domestic demand also held up well. Argus reckoned that China's total processed phosphate consumption fell by 2.5% in 2020 compared to 2019, to a total of 15.5 million t/a P_2O_5 for the full year. However, China's ministry of agriculture has mandated an increase in grain planting areas this year, including requiring rice farmers to plant two seasons of the crop, to ensure sufficient food supply, and this is likely to boost Chinese phosphate demand, as will higher corn prices and low domestic DAP stocks.

Cheaper sulphur and sulphuric acid prices during 2020 helped lower the costs of production for Chinese DAP producers, although these began to rise again towards the end of the year, mitigated slightly by China's recent announcement as from December 2020 that it will not charge import duties and value added tax on imports of sulphur.

Another boost for Chinese producers has been record Indian demand for fertilizer. Chinese exports of DAP were at 800,000 tonnes (product) in August 2020, 60% up on the previous year.

Looking forward

Chinese fertilizer consumption continues to be on a long term declining trend as farmers move to more efficient use of nutrient. The current Chinese MAP/DAP capacity rationalisation is drawing to a close, and there is more new capacity on the horizon. However, this will find some new regulations, such as restrictions on phosphogypsum storage, to be an additional burden, and may cap new production. Even in spite of this, however, there is a major overhang of idled capacity or capacity running

at low rates which could be ramped back up depending upon the price environment. Chinese sulphur demand, this depends very much upon international demand for processed phosphates. With more low cost DAP coming from Morocco and Saudi Arabia, Chinese producers may find themselves squeezed out of key markets. The general indication seems to be that the boom period for Chinese DAP production is over, and a slow period of decline is most likely for the medium term, aside from during temporary periods of market shortage. ■

Diammonium phosphate is the largest component of Chinese phosphate production.

PHOTO: 123RF

Fig. 1: Chinese phosphate production (million tonnes P_2O_5)

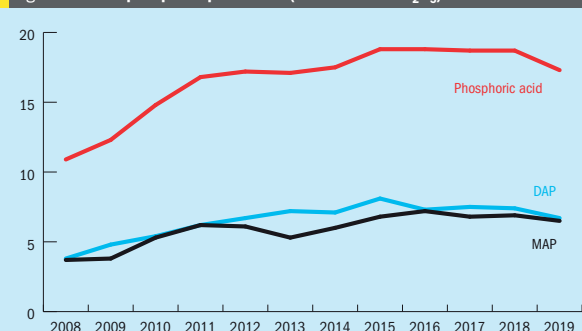

Source: IFA

CONTENTS

What's in issue 392

COVER FEATURE 1

Sulphur and plant health

COVER FEATURE 2

Canada's sulphur industry

COVER FEATURE 3

New sulphuric acid catalysts

COVER FEATURE 4

The water side of SRUs

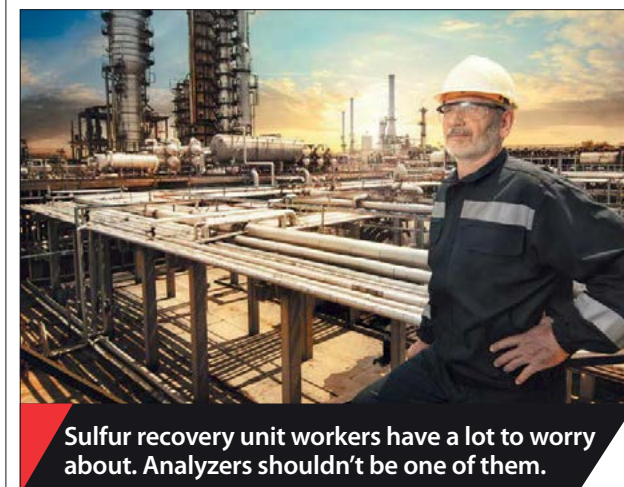

Sulfur recovery unit workers have a lot to worry about. Analyzers shouldn't be one of them.

Managing all the processes in a sulfur recovery unit (SRU) is arduous work—demanding skill, concentration, and dedication through every shift. Fortunately, the reliability, accuracy, robust design, and operating ease of AMETEK analyzers can make that tough work a little easier. AMETEK engineers have been designing industry-standard SRU analyzers for decades, and that shows in the products' accuracy, reliability, and longevity.

Because we make analyzers for every part of the process—from acid-feed gas to tail gas to emissions, including the gas treating unit, sulfur storage (pit) gas, and hot/wet stack gas—you get the convenience of one source for unparalleled engineering and support for all your analyzers, while your operators benefit from consistent interfaces and operating procedures.

For decades, we've been dedicated to making your SRU operation the most efficient it can be for the long term.

Learn more at www.ametekpi.com/SRU.

© 2020 by AMETEK Inc. All rights reserved.

AMETEK
PROCESS INSTRUMENTS

SULPHUR
ISSUE 392
JANUARY-FEBRUARY 2021

BCInsight

Southbank House, Black Prince Road
London SE1 7SJ, England

Tel: +44 (0)20 7793 2567

Fax: +44 (0)20 7793 2577

Web: www.bcinsight.com
www.bcinsightsearch.com

New catalysts target key industry challenges

Selecting the right catalysts for the SO₂ converter in a sulphuric acid plant has always been about balancing expenses, gains, and compliance. With increasing demands for sustainability and in challenging economic times, operators need to adjust their plants to get even more from less. This has led to market demand for new catalytic solutions that offer better productivity and a lower climate footprint, all at the lowest cost possible. Catalyst design and formulations continue to evolve with Haldor Topsoe, DuPont Clean Technologies and BASF all adding new types of sulphuric acid catalysts to their portfolios.

HALDOR TOPSOE

Tipping the scales with VK38+ catalyst

M. Granroth

VK38+ is a new potassium-promoted catalyst that is part of a range of proven, top-performing sulphuric acid catalysts from Topsoe. This catalyst stems from more than eight decades of catalyst innovation and is a move forward from existing solutions.

A successful catalyst needs to address three crucial parameters: high activity, good strength and low pressure drop. Typically, designing a catalyst is a compromise

between these parameters. It is difficult to improve one without sacrificing at least one of the others. With VK38+, Topsoe's R&D has succeeded in developing a new catalytic material that provides significantly higher activity than that of the regular VK38 at all relevant conditions. It does so without compromising the strength of the catalyst pellets. By using the well-proven Daisy shape, the pressure is at the same industry-leading low level as for the existing VK-range.

The versatility of VK38+ allows operators to target plant bottlenecks that could previously not be addressed, increase the flexibility of the plant, and ease stock management.

Fig. 1 illustrates how VK38+ can be applied to cut SO₂ emissions when converter space is limited. The achievable conversion is dependent on the catalyst volume available, with VK38+ higher conversion can be achieved with a fixed volume. As an example it is possible to increase conversion from 99.9% to 99.93% by moving from VK38 to the same volume of VK38+.

The graph also shows how the new potassium-promoted catalyst is situated between a regular potassium-promoted loading and a premium solution based on a caesium-promoted catalyst.

Furthermore, the graph shows how the new catalyst can be used alone, or together with premium catalyst, depending on the specific goals and requirements of the individual plant.

VK38+ offers superb activity over a wide range of operating conditions. While most high-performance catalysts are optimised for specific conditions, VK38+ stands out as the only catalyst on the market that can boost performance in all SO₂ converter beds.

Improved economics

For many operators, improving plant profitability involves maximising throughput at a minimum investment. Many operators have already taken this route and more often than not there is no room for additional catalyst. Operators are therefore forced to turn to more expensive specialty catalyst or even plant revamps to push performance further.

With VK38+, operators can tip the scales to their advantage and create a more cost-effective solution. VK38+ offers significant performance increases in all converter beds, without the cost increase associated with a caesium catalyst solution. This performance increase means there is a new option for operators who want to use increased capacity as a means to improve profitability.

Higher capacity can be achieved in two different ways: through increasing the feed gas flow or increasing the SO₂ concentration of the feed gas. From a catalyst perspective, increasing the feed gas flow is easier and allows for higher capacity without compromising conversion. With higher feed gas flow, an increase of more than 15% capacity can be achieved when replacing regular potassium-promoted catalyst loading with VK38+.

Higher gas flow does, however, increase energy consumption and may not be attainable if the main burner is already operating at full capacity, or if there are other constraints.

Increased SO₂ strength comes with its own set of potential bottlenecks but will typically not increase energy consumption and can still allow up to 5% higher capacity when switching to VK38+.

VK38+ is not only limited to increasing capacity. If higher capacity is not a goal, there are several other ways that it can have a positive impact on plant profitability. First, operating with higher SO₂ strength can also help operators reduce energy consumption and hence energy costs. This is described more in detail in the environmental section below.

Influencing possible cycle lengths with VK38+ can also help improve profitability for situations where higher capacity is not desired. The limiting factors dictating when a particular plant needs to shut down for turnaround varies, since each plant face its own unique set of conditions and constraints. Some of these are, however, related to catalyst performance. For these plants, applying VK38+ can significantly improve cycle length, since the activity

Fig. 2: Decreased environmental footprint

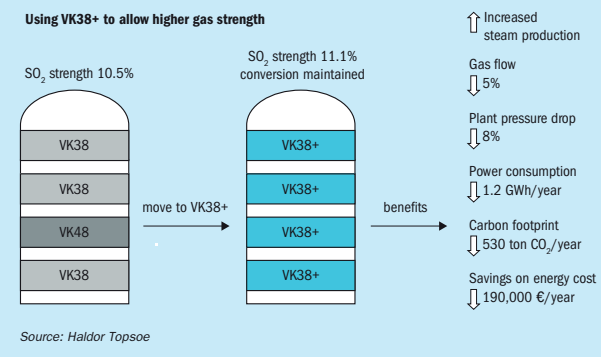

margin down to where sufficient conversion can no longer be maintained can be increased by as much as 100%.

Finally, the higher performance of the VK38+ can be leveraged for increased catalyst lifetime.

While pressure drop increase may force screening of a bed, with higher start of run activity the bulk catalyst can be used for longer before the overall activity drops to a level where the full beds need to be replaced to maintain conversion. Calculations show that the extra start of run activity translates to an up to 40% reduction of long-term catalyst spending.

Environmental performance

Environmental performance expectations are tightening globally. In Europe, a new Green Deal puts pressure on the industry to create more efficient and effective low-carbon technologies and reduce emission of SO₂ through a new Best Available Techniques reference document (BREF), which is on the horizon. In the United States, there has recently been a clear drive towards lower SO₂ emission on the state and federal level, and a similar Green New Deal puts focus on renewable energy and resource efficiency. The UN's Sustainable Development Goals (SDG) also target the Asia-Pacific region, which is under pressure to develop more sustainable solutions.

One of the primary objectives for any high-performance sulphuric acid catalyst is to help operators achieve low SO₂ emissions from their plants. This is important for plants to stay compliant with the new

environmental legislations outlined above, and also to reduce their environmental footprint. The VK38+ is no exception, and brings some clear advantages compared to traditional solutions (see Fig. 1).

A sulphur burner operating with a feed gas of 11% SO₂ can reduce emissions by around 30% by moving from a regular VK38/48 loading to a VK38+ loading of the same size. From an environmental footprint perspective, using VK38+ to reduce SO₂ has another advantage. Contrary to many non-catalyst solutions, it achieves the emission reduction without causing an increase in associated greenhouse gas emissions.

As mentioned previously, the higher activity of VK38+ can be leveraged to enable plants to operate with higher feed SO₂ concentration without sacrificing conversion. Higher SO₂ strength in turn allows plants to reduce feed gas flows without sacrificing productivity.

Fig. 2 shows how the CO₂ footprint and energy expenditures can be reduced by using VK38+ to allow unchanged capacity and emission at higher SO₂ strength and lower gas flow. For example, switching from a regular potassium-promoted loading to VK38+ can allow a 1,000 t/d plant to cut its CO₂ footprint by more than 500 tonnes/year through increased SO₂ strength. In addition to energy savings achieved through reduced flow, the change can also lead to increased steam production and an annual energy cost savings of €140,000.

Catalyst replacement can be dictated by a number of factors, low activity being one of the most important. Although the effects of deactivation can be temporarily mitigated through increased bed temperatures,

Fig. 1: Lower emission with the same volume

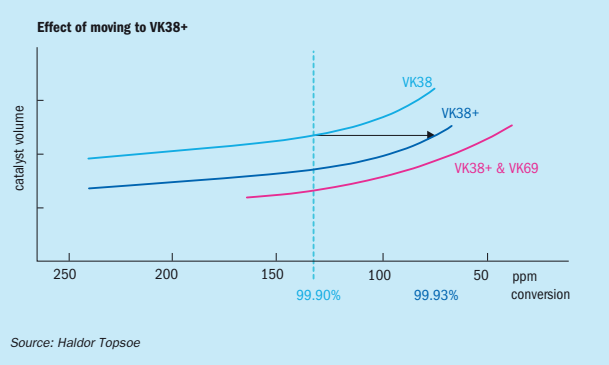

CONTENTS

What's in issue 392

COVER FEATURE 1

Sulphur and plant health

COVER FEATURE 2

Canada's sulphur industry

COVER FEATURE 3

New sulphuric acid catalysts

COVER FEATURE 4

The water side of SRUs

SULPHUR
ISSUE 392
JANUARY-FEBRUARY 2021

BCInsight

Southbank House, Black Prince Road
London SE1 7SJ, England
Tel: +44 (0)20 7793 2567
Fax: +44 (0)20 7793 2577
Web: www.bcinsight.com
www.bcinsightsearch.com

Fig. 3: Improved lifetime

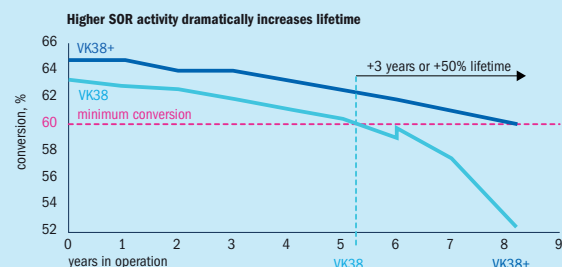

Table 1: Higher Bed 2 performance with VK38+

	VK38 prediction	VK38+ actual performance
SO _x /O ₂ feed composition, %	12.86 / 8.14	12.86 / 8.14
Bed 1 conversion, %	58.3	58.3
Bed 2 inlet temperature, °C	450	451
Bed 2 outlet temperature, °C	525	533
Bed 2 conversion, %	79.7	81.6

Source: Haldor Topsoe

eventually there will come a point at which it is no longer possible to maintain conversion at normal production rates. With its higher activity, VK38+ can be operated for longer, before activity falls below a point where emission targets can no longer be met. This effect and the corresponding longer lifetime are shown in Fig. 3. In this example the VK38+ is operated 55% longer before having to be replaced.

The longer lifetime presented in Fig. 3 translates to an up to 50% decrease in the volume of catalyst needed to maintain plant performance over time. With the metal content of the two catalysts being similar, the decrease in required catalyst volume also corresponds to a 50% reduction in metals needed to be mined and refined. Finally, using 50% less catalyst also means a 50% reduction in the spent catalyst that is generated in the process.

Overall, this contributes to a smaller environmental footprint for the sulphuric acid plant.

The extra flexibility discussed earlier also potentially reduces the environmental footprint. One example involves increased steam production. When operators add

VK38+ to beds 1 and 2, they can also use lower inlet temperatures, which allows for increased process energy extraction as valuable high-pressure steam. Overall, this makes VK38+ a powerful tool for improving sustainability across the industry.

A complete transition to a new SO₂ converter catalyst like VK38+ does not have to happen overnight, it can take place gradually and cater to the needs of the individual plant.

The new catalyst could also be phased in through the normal catalyst management scheme, replacing one or parts of a bed at a time as the existing catalyst reaches end of life.

VK38+ allows operators to:

- reduce emissions by ~35% over existing VK38/48 loading;
- lower catalyst waste and raw material use by ~50%;
- reduce power consumption by ~10% due to capacity for higher feed concentration;
- increase power output with higher steam production at the same load;
- decrease or avoid chemical consumption in existing scrubbers;

- reuse more existing catalysts;
- get more out of the existing plant and avoid the environmental footprint that comes from constructing new equipment and units.

Regardless of which approach is taken, switching to a better catalyst requires a strong partnership with the supplier. With good technical service, the right catalyst management strategy can be identified to address the operator's specific goals and constraints.

VK38+ is already in operation in two plants, one of them a 1,000 t/d sulphur burning sulphuric acid plant in Sweden. Here the new catalyst was used to replace regular VK38 that had been previously used since 2011 in Bed 2.

Together with a top-up of Bed 1, the new catalyst allowed the plant to operate with an unprecedentedly high SO₂ concentration, far higher than is seen for most other sulphur burning plants. Despite the high SO₂ concentration, the conversion outlet of Bed 2 is higher than what it used to be with the previous charge of VK38, and the temperature increase over the later beds decreased. While data for identical conditions are not available, the performance for the previous charge of VK38 has been simulated at the same conditions as VK38+ (See Table 1). The higher performance of the new catalyst could translate to 50% longer lifetime, or up to 5% higher capacity.

Conclusion

VK38+ is a new potassium-promoted catalyst from Topsoe that has been proven to have higher activity than any other catalyst

The development of VK38+ comes at the heels of tightening global legislation that poses challenges to sulphuric acid plants, many of which already operate with fully loaded converter beds. With VK38+, operators can better live up to these demands and decrease their plants' environmental footprints. The result is better economics, lower emission and less waste. ■

References

1. CO₂ intensity of electricity generation.
2. Donat, L. Schindler, H. and Burck, J.: "Brown to green: The G20 transition towards a net-zero emissions economy", Climate Transparency, pp. 30 (2019).
3. Electricity price: Xenellis, G. "1.4 Energy prices, Non-households 2018", Energy, transport and environment statistics, pp. 36, Eurostat (2019).

DUPONT CLEAN TECHNOLOGIES

MECS® advanced catalysts help manage and reduce sulphuric acid plant emissions

T. Brouwers, H. Cardwell, C. Pereira and C. Kulczycki.

Catalyst is at the heart of all sulphuric acid plants and plays a critical role in plant performance. This article provides an overview of the specific design features of two new types of MECS® sulphuric acid catalyst developed by DuPont Clean Technologies (DuPont), XLP-310 and SuperGEAR™, and explains how these more advanced catalyst types can be applied to reduce emissions or increase the capacity of a sulphuric acid plant.

When asked about key challenges, sulphuric acid plant operators invariably name three issues:

- operational targets – run-times that are as long as possible and start-ups that are as fast as possible;
- emissions control or improvement;
- economic factors – aligning the objectives above with the economic reality: running the plant at the highest possible capacity while consuming as little energy as possible.

The DuPont Clean Technologies R&D team keeps all three challenges in mind when developing new and improved types of catalyst. Although there are many factors which impact catalyst performance, formulation and shape are two of the key considerations in the design of advanced new catalyst.

Impact of catalyst formulation on conversion

Catalyst is composed of alkali metal, vanadium salts and a diatomaceous earth support. Under reaction conditions, molten alkali metal vanadium pyro-sulphates are formed. These molten salts are supported within the pore structure of the diatomaceous earth. The accepted mechanism for sulphur dioxide oxidation to form sulphur trioxide is a catalytic redox cycle that involves V5+ and V4+ species in the supported liquid phase. The composition of active salts in the liquid phase, as well as accessibility to those salts by the gas stream, plays a large role in the activity level of the catalyst.

In addition to catalyst activity, conversion is impacted by many factors including, but not limited to, gas composition and inlet temperature to each pass,

Fig. 1: Temperature optimisation of a four-pass converter

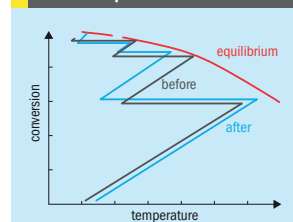

catalyst volume and converter design. In some cases, temperature optimisation alone can allow plants to reach their emission goals. Fig. 1 shows the typical profile of a four-pass converter (before and after temperature optimisation) and illustrates that, ultimately, the conversion of SO₂ to SO₃ is limited by the equilibrium curve.

Traditionally, many plants have added caesium catalyst, which allows for lower operating temperatures and therefore a closer approach to equilibrium, to the fourth pass of their converter in order to reach their desired emission levels. However, thanks to advances in catalyst shape and formulation, many plants can now reach their emission goals without the addition of caesium catalyst through application of more active catalyst in upstream passes of the converter.

Benefits of advanced catalyst shape

For a nominal pellet size, pressure drop in the converter is largely determined by catalyst shape. Ten years ago, DuPont developed the MECS® GEAR® catalyst, which has a unique hexa-lobed ring shape. The new shape created an increased spacing between the rings and thus allowed the gas to pass through the catalyst bed more easily than was possible with traditional ring-type catalysts (see Fig. 2). That not only means a lower pressure drop but also translates into energy savings, as less power is required to operate the main blower.

Dust handling is another factor regulated by the catalyst shape. Most of the dust that

Fig. 2: Relative pressure drop for clean catalyst

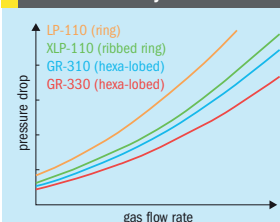

enters the converter is collected in the first pass. If the dust collects at the top of the bed, the pressure drop across the bed will build up faster, which results in shorter run-time between shutdowns. The shape of the MECS® GEAR® catalyst was designed to allow dust to penetrate throughout the bed instead of accumulating at the top. In this way, more dust can be collected before it starts to block the gas flow and cause an increase in pressure drop. The net result is that operators can extend the time between maintenance shutdowns. Fig. 3 illustrates the expected bed life when using different catalyst shapes.

Finally, catalyst shape and the geometry of the individual lobes determine the way in which rings nest into each other and therefore decide the total catalyst surface area per volume of catalyst. The greater the surface area, the greater the interaction of the gas molecules with the catalyst and the higher the final activity. This is exactly what the MECS® GEAR® shaped catalyst set out to achieve, hence its name: GEAR – Geometrically optimised, Enhanced surface area for Activity improvement and Reduced pressure drop.

Latest catalyst advances increase activity

The most recently developed MECS® SuperGEAR™ and XLP-310 catalysts are based on an innovative, improved formulation in combination with the existing ribbed and hexa-lobed ring shapes to ensure pressure drop and dust handling

Fig. 3: Impact of catalyst shape on bed life

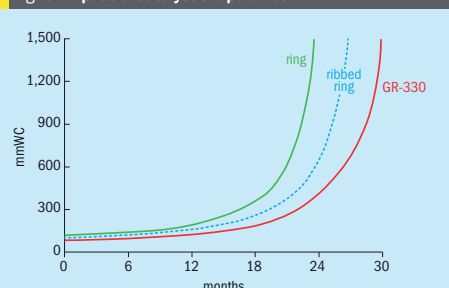

Source: DuPont Clean Technologies

levels are maintained. The enhanced formulation translates into significantly higher activity levels than the previous generation of catalyst. The volume-based activity of the XLP-310 is more than 50% higher than conventional ribbed ring catalyst and the volume-based activity of the MECS® SuperGEAR™ hexa-lobed catalyst is 65% higher. Performance of both XLP-310 and SuperGEAR™ has been proven through numerous installations in the field.

Benefits of improved activity in an existing plant

Selective addition of the catalyst to critical passes can lead to dramatic results. Plant emissions can be reduced while holding capacity steady, or plant capacity can be increased while maintaining the same emission levels. In some cases, plants may choose to lower emissions to reduce reagent costs of downstream scrubbers or to comply with new environmental regulations. Or they may expand capacity to increase production of finished goods from other parts of their site. Of course, it is only possible to improve plant capacity to the extent that other plant bottlenecks or the hydraulic limit of the blower allow.

Another way of looking at the performance of these advanced catalysts is to consider catalyst loading versus conversion. The same loading of catalyst in the bed can provide a higher conversion, or the same conversion may be obtained with a lower loading. As with all major revamps, DuPont uses its proprietary design software for MECS® catalyst to provide customers with achievable improvement levels based on current operating conditions.

Fig. 4: Emissions reductions with new catalysts

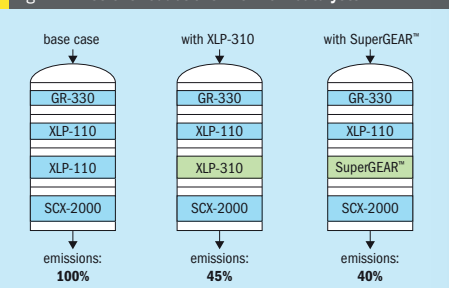

Source: DuPont Clean Technologies

Table 1: Results of catalyst replacement on capacity and emissions

	Year 1		Year 4	
Relative capacity	1.00		1.12	
Relative emissions, ppm	1.0		0.4	
	Catalyst	Per pass conversion, %	Catalyst	Per pass conversion, %
Pass 1	XLP-110	56.5	GR-330/XLP*	60.7
Pass 2	XLP-110	61.1	XLP*	61.2
Pass 3	XLP-110	55.0	XLP-310	65.7
Pass 4	XLP-110	91.9	XLP-310	95.2
Cumulative conversion	99.5%		99.8%	

* mix of XLP-110 and XLP-310

Source: DuPont Clean Technologies

The new MECS® XLP-310 catalyst

Although MECS® XLP-310 may be used in any pass, maximum benefit is derived when it is used in converter passes 2 and 3, as well as in pass 4 if there is no caesium. Fig. 4 provides a comparison with a standard XLP-110 catalyst and MECS® SuperGEAR™ catalyst. As can be seen in the scenario shown, complete replacement of XLP-110 with XLP-310 in pass three, with no modifications to passes 1, 2, or 4, has the potential to dramatically reduce emissions.

The advanced MECS® SuperGEAR™ catalyst

The new MECS® SuperGEAR™ catalyst combines the pressure drop and dust handling advantages of the hexa-lobed ring shape with an improved formulation that provides greater activity. This catalyst was mainly

developed for new plants where use of MECS® SuperGear™ catalyst will optimise the capex versus performance. Although maximum value is achieved in new installations, just as with MECS® XLP-310, MECS® SuperGEAR™ can also be selectively applied in existing converters, allowing for a further reduction in emissions.

Application examples

Achieving conversion goals through XLP-310 without major capex

A DuPont client, operating a very large capacity sulphur burning plant, made the decision to renew the company's commitment to sustainable operation by setting even more stringent emission goals for its plant. At the same time, the company realised that additional capacity would be required in order to support fertilizer production. An evaluation by DuPont

determined that the site could meet its goals by focusing on passes three and four of the converter, and that expensive heat exchanger or converter modifications, as initially feared, were not necessary.

Based on DuPont recommendations, the company gradually upgraded the catalyst in its converter over the course of four years. The upgrades included complete new beds of MECS® XLP-310 in passes 3 and 4, installation of MECS® GR-330 in pass one and a partial installation of MECS® XLP-310 in pass 3. The result was an overall conversion increase from 99.5% to 99.8% and a 60% reduction in emissions, at the same time as an expansion in plant capacity of 12% (see Table 1).

Increasing capacity while reducing pressure drop with MECS® SuperGEAR™

For a planned major plant revamp, one DuPont customer is choosing the superior performance of MECS® SuperGEAR™ over other ribbed catalysts. By using caps of SuperGEAR™ in passes 2 and 3, as well as MECS® SCX-2000 catalyst in pass 4 in

the new converter, the company expects to increase its capacity by approximately 25%, reduce overall pressure drop and maintain conversion. The high activity of SuperGEAR™ should enable the plant to use 13% lower loading than with standard ribbed catalyst, as well as reduce the expected pressure drop by 13%. SuperGEAR™ will allow them to save on initial capital costs as well as reduce their operating costs over time.

Viability of catalyst-triggered capacity and emissions improvement

Sulphuric acid plant operators with an existing converter who want to improve emission levels should carry out a full and detailed analysis of their current operations to have a clear understanding of realistically achievable outcomes DuPont uses the MECS® PeGASys™ analysis system which measures the SO₂ conversion of every pass to provide a full picture of the performance of each bed. This data is then evaluated with the help of the MECS® catalyst design program,

which predicts what improvements can be achieved using the newly developed catalysts. Sometimes, the PeGASys™ analysis shows that a simple adjustment of the converter temperature is sufficient to achieve an improvement in plant performance. PeGASys™ measurements could also reveal if it is not the catalyst that is the root cause of a production issue, but in fact another part of the plant that requires maintenance such as the gas-to-gas heat exchanger.

Conclusion

If all other equipment is functioning correctly, advances in catalyst design and formulation can offer significant capacity and emissions improvements. The choice of options available allows sulphuric acid plant operators to select a catalyst mix that matches their production and emissions objectives at the same time as cutting energy consumption, accelerating start-ups and increasing run-times between shutdowns.

BASF

Customised bed solutions with new Quattro catalysts

J. Kim, M. Kennema, M. Grobys, D. Hensel and C. Walsdorff

BASF has produced sulphuric acid for various industrial applications since 1866 and has been producing catalyst for the sulphuric acid process since the early 20th century. A first patent for a vanadium pentoxide catalyst was granted to BASF in 1913. Today, BASF is operating six sulphuric acid and 13 sulphonation plants with inline SO₂ oxidation units worldwide all using BASF's in-house catalyst technology with world class plants operating at emission levels below 50 ppm SO₂. The last 15 years have brought new challenges such as tighter emission regulations and cost pressure to the sulphuric acid market. This has led BASF to be on the forefront with cutting-edge research into one of the oldest catalysts of the portfolio.

Customer focus

In alignment with the new strategy of BASF, the focus on sulphuric acid producers and their needs is ever greater, driving improvements of catalyst technology.

BASF works directly with customers to make sure customers achieve the best performance under the specific design and operation conditions of their reactors. This is enabled through BASF's state-of-the-art testing facility and analytics combined with more than 150 years of research and experience.

New extruded shapes

Sulphuric acid catalysts are generally produced by extrusion of a precursor paste to yield shaped catalyst bodies. The extrusion process not only defines the shape of the catalyst bodies, but also impacts other crucial properties such as pore structure and mechanical stability of the catalyst. These properties are also related to the fluid properties of the precursor paste in the extrusion device. Eventually, the extrusion process has to cope with pastes of varying composition for different catalyst types. Fluid properties of precursor paste and control of the entire extrusion process are strongly determined by the specific



Fig. 1: BASF Quattro catalyst.

design of extrusion dies. Especially the detailed design of internals of the dies has a significant impact on quality and capacity of extrusion. This becomes an immediate challenge, when entirely new shapes for a catalyst family shall be extruded and new dies have to be found.

www.sulphurmagine.com

CONTENTS

What's in issue 392

COVER FEATURE 1

Sulphur and plant health

COVER FEATURE 2

Canada's sulphur industry

COVER FEATURE 3

New sulphuric acid catalysts

COVER FEATURE 4

The water side of SRUs

SULPHUR
ISSUE 392
JANUARY-FEBRUARY 2021

BCInsight

Southbank House, Black Prince Road
London SE1 7SJ, England

Tel: +44 (0)20 7793 2567

Fax: +44 (0)20 7793 2577

Web: www.bcinsight.com
www.bcinsightsearch.com

Table 1: Customers' challenges addressed by the new BASF Quattro catalyst

Typical issues	Can Quattro help?	How?
High emission levels	Yes	Higher geometric surface area resulting in better SO ₂ conversion.
Production capacity bottleneck	Yes	Higher geometric surface area allows for increased production rates at historically high conversion levels.
Limited bed height	Yes	Higher geometric surface area allows for higher space-time-yield.
Low ignition temperature	Yes	Higher geometric surface area resulting in better SO ₂ conversion at low temperature.
Wider operational range	Yes	The low activity of the Quattro catalyst allows for a much wider operational range.

Source: BASF

Commitment and continuous progress in extrusion technology has been a key for successfully turning a lab idea into an established and reliable commercial product. Here, BASF can make full use of the Technology Verbund with in-house competence on computational fluid dynamics (CFD) and metal powder 3D-printing technology to develop and optimise dies for extrusion devices. This is evidenced by an international patent family filed by BASF on extrusion dies for catalyst production (WO2019/219892 A1).

In 2016, after years of catalyst development, BASF launched O4-115 with the Quattro geometry (Fig. 1, WO2016/156042 A1 and WO 2019/170406 A1) leading to 5-8% increased plant capacity in the first commercial application. Many additional customers have chosen the Quattro geometry since, all benefiting from performance improvements.

In early 2020, BASF introduced the Quattro catalysts O4-110 and O4-111, the newest members of the Quattro family. These vanadium-based catalysts allow sulphuric acid producers to boost production capacity significantly, reduce SO₂ emissions, extend turnaround schedules and shorten start-up time leading to significant cost savings. These latest developments allow customised catalyst bed solutions to be created for unique applications worldwide. Continuous innovation and creative thinking continue to define BASF as a global innovation leader in catalyst research.

O4-115 Quattro development and application

In 2017, first long-term results from the Quattro catalyst development were described and demonstrated:

- 5-8 % increased production capacity;
- increased conversion with increased SO₂ feed content and reduced O₂/SO₂ ratio;

Table 2: Conversion at DOMO Caproleuna plant 2016-2019

Conversion comparison BOSS 100 (%)					
Date of measurement	Bed 1	Bed 2	Bed 3	Bed 4	Bed 5
Quattro					
26.10.2016	58.3	80.8	90.6	99.5	99.84
16.05.2017	57.8	78.3	89.7	99.5	99.84
25.04.2018	47.3	66.3	88.3	99.2	99.79
26.02.2019	48.4	67.3	87.7	99.1	99.78
11.09.2019	48.2	67.1	87.5	99.1	99.80

Source: BASF

Table 3: O4-115 Quattro properties vs. star rings

	Star Ring O4-115	Quattro O4-115
Packing density, kg/m ³	450	450
Relative geometric surface area, %	100	130
Relative pressure drop, %	100	105-110
Cutting hardness, N	>70	>110
Attrition, %	<2.0	<1.0
Active range, °C	390-630	370-630
Ignition temperature, °C	340	330

Source: BASF

- no increase in pressure drop across the O4-115 Quattro bed;
- flexibility across varying O₂/SO₂ ratios.

The development of the Quattro shape geometry addresses several common customer challenges when operating a sulphuric acid plant (Table 1).

In 2018 the DOMO Caproleuna Plant observed a decreased conversion over the first two beds of the sulphuric acid plant. Under normal conditions, this would have led to an increase in SO₂ emissions and potentially a forced shutdown to replace the catalysts in the first bed. However, BASF's Quattro catalyst in the 4th bed of

the sulphuric acid plant was able to make up for the decreased conversion in the first two reactor beds, preventing a significant increase in SO₂ emission in the off-gas of the plant (Table 2).

In addition to the significant increase in geometric surface area of the Quattro shape geometry, which yields up to 30% higher activity, the mechanical properties of the Quattro catalyst have set it into a class of its own when compared to current state-of-the-art star-ring-type catalyst geometries (Table 2).

With 50% higher side-crush-strength and approximately 50% lower attrition compared to star-ring catalysts the predicted

Table 4: Physical properties of the O4-115 Quattro catalyst after one year in the plant

	Star Ring	Quattro after 1 year
Cutting hardness, N	>70	>90
Attrition, %	2.1	1.2

Source: BASF

loss on sieving for the Quattro catalyst is significantly lower than that of the star-ring type catalyst reducing refill costs.

The greatest attribute of the O4-115 Quattro catalyst is the wider operational range and the lower ignition temperature (Table 3). This allows for a much lower start-up temperature and a much broader operational range of the reactor.

The physical data taken from the DOMO Caproleuna plant also support the original lab data detailing the decreased attrition loss and the high mechanical stability of the Quattro catalyst (Table 4).

O4-110 / O4-111 Quattro development and application

Even though the O4-115 Quattro catalyst already shows a significant improvement compared to the state-of-the-art shape geometries, BASF is further committed to providing customers with the best possible solution for challenging demands such as improving throughput of existing units while decreasing SO₂ emissions to meet more stringent environmental requirements.

To meet this challenge, BASF extended the Quattro family to O4-110 and O4-111 Quattro (Fig. 2). As in the case of the O4-115 Quattro catalyst advantage is taken of the increased geometric surface area of the new shape geometry to push the production capacity of existing



Fig. 2: BASF O4-111 Quattro catalyst.



Fig. 3: Reactor bed of Quattro catalyst.

sulphuric acid units, providing a catalyst which requires a lower loading mass and offers a significant performance advantage compared to all standard star-ring type catalysts.

The most impressive outcome of the O4-110 and O4-111 catalyst shape geometry is the increased active range of the catalyst especially at low temperature. The decrease in ignition temperature is driven by the higher geometric surface area which

Table 5: Quattro properties vs. star-rings

	Star Ring O4-110	O4-110 Quattro	Star Ring O4-111	O4-111 Quattro
Packing density, kg/m ³	450	450	450	450
Relative geometric surface area, %	100	130	100	125-135
Relative pressure drop, %	100	105	100	100-105
Cutting hardness, N	>70	>110	>70	>110
Attrition, %	<2.0	<1.0	<2.0	<1.0
Relative activity, %	100	130	100	125
Active range, °C	420-630	400-630	410-600	390-600
Ignition temperature, °C	380	360	360	350

Source: BASF

allows more accessibility to the active sites at low temperature. This increases the active range of the catalyst.

Another major advantage is that sulphuric acid producers can lower the amount of catalyst required for a reactor filling while at the same time increasing conversion. This means pressure drop in the reactor can be decreased without compromising on conversion. In fact, this can even lead to the highly desirable situation of increased conversion with a lower pressure drop. The lower catalyst loading of the BASF O4-111 or O4-110 quattro catalyst is possible again due to the increased geometric surface area (Table 5).

Since 2016 the Quattro catalyst family has been installed in numerous plants globally, each time confirming the expected performance improvements described earlier: "Due to technical limitations we are not yet at full capacity, but the performance of the bed loaded with Quattro catalyst is already remarkable."

DOMO Caproleuna, Germany, loaded two additional beds with O4-111 Quattro during the turnaround in 2020. Ulf Müller, Director Operations Inorganic Precursors and Fertilizers comments, "It is clear that the new catalyst has an excellent performance. With a capacity of 3% above the project load, we still have reserves in performance and conversion. So far, we could not detect an increase in pressure drop across the catalytic converter."

In summary, the O4-115, O4-110 and O4-111 BASF Quattro catalysts offer lower ignition temperatures, higher conversion and higher strength than conventional catalysts (Fig. 3). This directly translates into increased operational flexibility and significant cost reduction for sulphuric acid producers.

SRU troubleshooting tools

Process and simulation models can be valuable tools when troubleshooting to solve operational issues in sulphur recovery units. Two examples are provided. In the first case study it is shown how a tuned model was useful in troubleshooting an SRU that was experiencing lower than expected recovery efficiency and apparent channelling in the first catalytic converter. In the second case study an SRU simulation tool is used to investigate sulphidic corrosion in a waste heat boiler.

SULFUR RECOVERY ENGINEERING (SRE)

The merits of tuned simulations

I. S. Mohammed

Fig. 1: First converter temperature profile by year

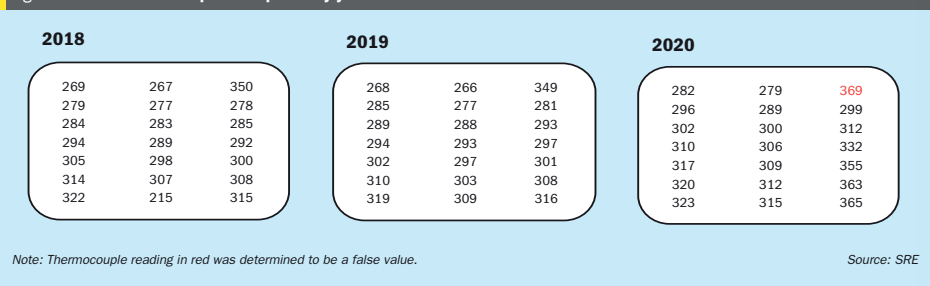

At one time, unit engineers were allowed to spend their time identifying problems, spending large amounts of time creating simulations, gathering data, conducting analysis of that data, calculating different variables, and then verifying their hypotheses, all to improve the operation of their units. As margins have become tighter and objectives have shifted, it is now common to see unit engineers with very little extra time, if any at all, beyond firefighting the latest issues at their facilities. Now, gaining a realistic and appropriate solution for their problems within an efficient timeframe is essential. One could argue that having a solution that is ready to solve their problems, right out of the box, could be an asset. As George Box once said, "All models are wrong, some are useful."

SRE strives to provide that solution to its clients through tuned simulations. SRE utilises its gas chromatograph analyses to adjust the unit operations within a sulphur recovery unit created within Symmetry (a

Schlumberger software). The compositional analyses of the feed streams and the inter-stage process streams are all generated by SRE engineers who collect and analyse the samples themselves to ensure complete control of the chain of custody. Ensuring accurate results is also bolstered using SRE's GC application which analyses 33 compounds, including trace sulphurs, within a 5-minute run time. With these GC results, the thermal reactor can be tuned such that the hydrogen, carbonyl sulphide, and the carbon disulphide productions match that of the test period. Likewise, the catalytic converters are tuned to ensure the hydrolysis rates and the approach to equilibrium match the catalyst performance. Once aggregated together, the final simulation can be considered an accurate offline steady-state model of the SRU.

Using such a model can help solve some operational issues. For example, for a recent client, the facility was experienc-

ing lower than expected recovery efficiency and apparent channelling in the first catalytic converter (Converter 1). As seen in Fig. 1, the converter temperature profile shifted dramatically between the 2019 and 2020 test periods. In between that time, there was an operational upset which resulted in an exotherm of the catalyst. After the upset, the thermocouple profile illustrated that the process gas was mainly running along the right side of the converter, as marked by the increased exotherm along that wall. The slightly lower recovery efficiency that followed suit after the upset made the operator fearful that permanent damage to the catalyst had taken place.

To troubleshoot the lower recovery efficiency and to evaluate the catalyst, SRE was brought in to conduct a performance evaluation of the SRU train. In so doing, SRE collected gas samples necessary to create the tuned SRU model. Samples must be collected across all unit operations which change the composition of the process gas.

For example, samples of the inlet and outlet of the thermal reactor are required, but if there is a steam reheater in between the thermal reactor and the first catalytic converter, the inlet to the catalyst is already accounted for by the outlet of the thermal reactor. This would not be the case if the reheat method were to introduce a compositional change, like an acid-gas-fired reheater where the heat of the burn product of acid gas with air is combined with the process gas to heat it up to the desired temperature for the modified-Claus reaction. There is a compositional change across a condenser, in which the sulphur vapour drops out as liquid sulphur, but since GCs do not measure sulphur vapour or water, from an analytical perspective, the composition is the same. To make up for the lack of measurement of the condenser throughput, SRE measures the rundown for facilities with traditional sulphur seal leg look boxes. Otherwise, an assumption is needed; that the outlet temperature of the condenser is reflective of its theoretical

performance. With the samples collected in duplicate for repeatability, the tuned simulation model of the SRU was created.

Typical sample points collected to create a tuned-simulation of a 3-stage Claus plant are:

- acid gases to the thermal reactor;
- co-firing gas, if applicable (natural gas, refinery fuel gas, or hydrogen)
- condenser 1 outlet;
- reheater 1 outlet, if a direct fired reheater;
- condenser 2 outlet;
- reheater 2 outlet, if a direct fired reheater;
- condenser 3 outlet;
- reheater 3 outlet, if a direct fired reheater;
- condenser 4 outlet.

In reviewing the simulation data, the catalyst within the first converter was found to be fully active but the performance of the sulphur train was hindered. It was found that the hydrolysis rates had decreased from the last test period. A loss of carbonyl sulphide and carbon disulphide hydrolysis

rates can be a precursor to the loss of catalytic activity. The loss of recovery efficiency was partially due to the loss in hydrolysis but was found to be mostly caused by the loss in conversion within the thermal reactor. A lower acid gas quality resulted in lower thermal conversion and the low turnaround of the SRU train exasperated the reduction in performance. So, even though there were no extreme repercussions from the thermal incident, the tuned simulation model made it apparent that some damage had been done. SRE helped the client further by recommending a heat soak. This action helped to clear the channelling which was occurring and helped to regain some of the lost hydrolysis.

This example illustrates how a tuned model can be useful in troubleshooting an SRU. Further, as an offline steady state model, the model now has better predictive capabilities than the typical thermodynamic properties and can be used by the unit engineer for future troubleshooting. ■

OPTIMIZED GAS TREATING, INC. (OGT)

Sulphidic corrosion in a Claus waste heat boiler

N. A. Hatcher, S. A. Weiland, R. H. Weiland

Sulphidic corrosion and thermal cycling in Claus waste heat boilers (WHB) are the two leading causes of unscheduled shutdowns of sulphur recovery units (SRUs). Sulphidic corrosion is caused by high temperatures, typically exceeding 650°F (343°C), in conjunction with hydrogen sulphide (H₂S). These conditions are especially prevalent in the reaction furnace and WHB at the SRU front-end. Metal surfaces are thermally protected by refractory lining. Additional protection is by ceramic ferrules around the tube-to-tubesheet transition joint as well as inside the first 6-12 inches (15-30 cm) of heat transfer tubing where most WHB failures occur.

Tube metal temperature is affected by the heat flux from the hot process gas through the tube wall to the cooling utility water/steam. The hotter the tube walls, the higher the heat flux, making the heat flux of vital concern when designing a WHB or when managing changes to SRU operating conditions. Oxygen enrichment also can have a profound effect on heat flux, changing a borderline thermal condition into a catastrophic failure.

Sulphidic corrosion is generally calculated based on the widely-accepted

Couper-Gorman¹ curves which, at least for high heat fluxes, have been very closely confirmed by measurements made by Alberta Sulphur Research Limited (ASRL) for carbon steel. Couper-Gorman curves are also available for a variety of chromium-containing metallurgies and are generally used to assess corrosion in systems containing H₂ and H₂S, typified by Claus WHBs. The Couper-Gorman curves were modified downwards by a factor of between two and three by Martens² based on personal experience, but the original curves were subsequently validated by ASRL.

Case study

A North American refinery was considering oxygen enrichment to increase the capacity of its Claus unit. Oxygen enrichment can be a simple and inexpensive way to push more sulphur through a plant without large capital expenditure. Increasing the oxygen content of the combustion air allows part of the diluent nitrogen to be replaced with H₂S. Although oxygen enrichment has been practiced for many years, there has been a tendency for more frequent failures from the concomitantly higher operating temperatures.

Fig. 1 shows a typical three conversion stage SRU with a front-side split design on the reaction furnace, and a two-pass WHB. In addition to amine acid gas (AAG), the unit processes sour water acid gas (SWAG) with high ammonia content. As designed, the SRU operates on air only. In this instance, the WHB steam generation pressure is somewhat elevated at just over 650 psig (44.8 barg). Normally, WHBs are designed to operate in the range 300-600 psig (20-40 barg). This will be important later in the discussion.

Operating with air only

To establish a baseline, the WHB with carbon steel tube metallurgy was simulated under its present operating conditions using the SulphurPro[®] simulator. Sulphidic corrosion calculations based on recent ASRL research data and the Couper-Gorman plots reduced to correlations are built directly into SulphurPro[®]. The model provided a good picture of the heat transfer characteristics along with an estimate of the present corrosion rate in the WHB. The black line in Fig. 2 shows the tube wall temperature through the first pass of the WHB under current air-only baseline conditions.

What's in issue 392

COVER FEATURE 1

Sulphur and plant health

COVER FEATURE 2

Canada's sulphur industry

COVER FEATURE 3

New sulphuric acid catalysts

COVER FEATURE 4

The water side of SRUs

SULPHUR
ISSUE 392
JANUARY-FEBRUARY 2021

BCInsight

Southbank House, Black Prince Road
London SE1 7SJ, England

Tel: +44 (0)20 7793 2567

Fax: +44 (0)20 7793 2577

Web: www.bcinsight.com
www.bcinsightsearch.com

Fig. 1: SRU configuration

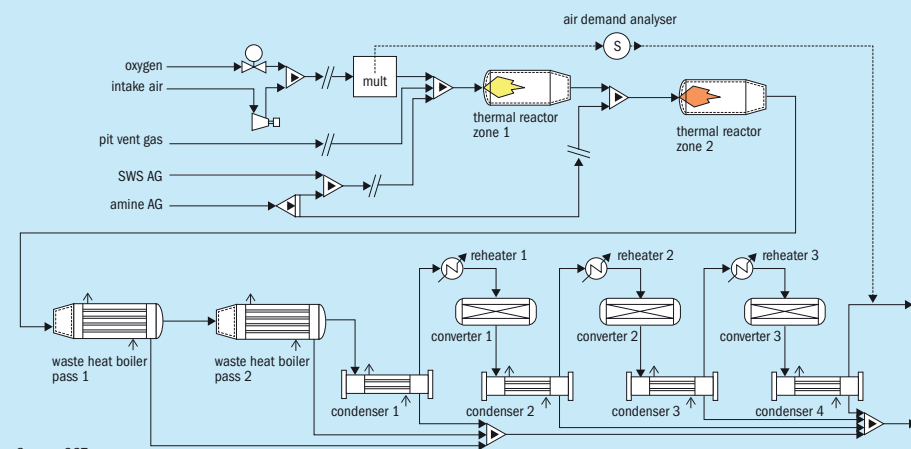

Source: OGT

Fig. 2: Tube wall temp. in WHB pass 1

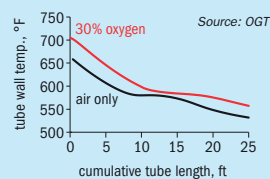
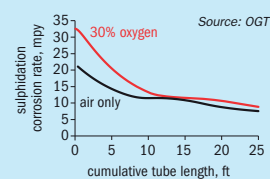

Fig. 3: Corrosion rates in WHB pass 1



The front of the WHB (Pass 1) is where the tube wall temperature (and the heat flux) are highest. The tube wall temperature is slightly elevated at just over the recommended maximum value of 650°F. The black line in Fig. 3 shows the sulphidic corrosion rate in the first pass for the air-only base case. The predicted peak corrosion rate is just over 21 mils per year (mpy). It is somewhat alarming that even with air-only the peak corrosion rate at the front of the WHB is already twice the recommended limit of 10 mpy. With the elevated steam generation pressure the utility-side temperature is also higher so a hotter tube wall is needed to drive the heat transfer, causing the corrosion rate to increase.

Oxygen enrichment

Having established the base case, oxygen content of the combustion air was increased to 30% and the acid gas rates increased to keep the same overall hydraulic throughput

in the SRU. The red lines in Figs 2 and 3 correspond to 30% oxygen enrichment. The tube wall temperature has now risen to over 700°F (371°C) at the inlet and the predicted sulphidic corrosion rate has gone to over 32 mpy. While that may not sound like a large increase, it is 50% higher than the base-case air-only operation which was already twice the recommended maximum, this in a piece of equipment liable to catastrophic failure with a high replacement cost and a potentially long lead time! Even low-level oxygen enrichment has compounded an already existing problem, producing a corrosion rate nearly three times the industry recommended maximum.

Increased sulphidic corrosion stemmed in part from oxygen enrichment, but also from the unusually-high utility-side pressure which resulted in elevated tube temperatures. The effect of utility-side pressure is to increase the predicted corrosion rate from about 11 mpy to over 32 mpy over the

utility-side pressure range 150-650 psig. This may help to explain why WHB failures have become more commonplace with high-pressure steam generation, especially when using oxygen enrichment.

Summary

Even with a very modest level of oxygen enrichment and quite a low utility-side pressure it is possible for a WHB to show concerning levels of sulphidic corrosion at and near the inlet tubesheet of the boiler. When considering oxygen enrichment, the possibility of elevated corrosion must be given careful attention. It may not be enough just to lower the steam generation pressure to compensate. Oxygen enrichment can be a risky undertaking demanding assessment of multiple possible consequences. There is no substitute for a well-founded SRU simulation tool with high reliability that takes fully into account all the fundamentals of radiative and convective heat transfer, process chemistry, and the kinetics of all the reactions. ■

References

1. A.S. Couper A.S. and Gorman J.W.: Computer correlations to estimate high temperature H₂S corrosion in refinery streams", Materials Protection and Performance 10(1) 31-37, (1971).
2. D.H. Martens D.H.: "Tube and tube weld corrosion and tube collapse", Brimstone Conference, Vail, CO, (12-16 Sep 2011).

Fire prevention and suppression for molten sulphur tanks and pits

Fires are known to occur in sulphur storage pits and tanks somewhat frequently due to the presence of both flammable material and air, so methods for preventing and extinguishing these fires are critical. **D. J. Sachde, K. E. McIntush, C. M. Beitler, and D. L. Mamrosh** of Trimeric Corporation review fire suppression methods used in the industry including snuffing/sealing steam, rapid sealing, water mist, and inert gas blanketing. Protective tank design features to reduce the likelihood of a sulphur fire are also reviewed. Benefits and limitations, design considerations, and recommended guidance for suppression and preventative measures are discussed.

Hydrogen sulphide (H₂S) is a byproduct of processing natural gas and refining crude oils, which generally must be removed and controlled. A modified Claus sulphur recovery unit (Claus SRU) is a method for converting the removed H₂S to molten elemental sulphur. The molten sulphur from a Claus SRU is stored and handled in several steps, as depicted in Fig. 1.

The sulphur from the Claus unit often flows to a sulphur pit or receiving vessel and contains approximately 300 ppmw H₂S and H₂S_x^{2,3,4} although oxygen enrichment and subdewpoint operation can produce higher H₂S levels, e.g. 450 ppmw⁵. The sulphur may be degassed in the pit or in separate equipment to reduce H₂S concentrations to ~10 ppmw. However, undegassed sulphur is common and should be considered in any molten sulphur handling design in the event the degassing system is not functioning. The molten sulphur often flows from the pit to a storage tank for offloading and transport.

The storage pit and tank represent areas where explosive vapours may accumulate and other hazardous conditions may develop as part of the operating conditions of the system⁶. Multiple sulphur species may be present and should be considered when evaluating the risks of the system^{7,8}. This article focuses on the hazards associated with sulphur fires in molten sulphur

storage applications. A summary of industry guidance, standards, and/or common practices for preventing and suppressing sulphur fires is presented.

Fire and explosion hazards in molten sulphur storage

Flammable components

Hydrogen sulphide is present in the molten sulphur and vapour space of storage and handling equipment. The flammability window of H₂S is denoted by upper and lower explosive limits (UEL and LEL). In molten sulphur handling applications, the LEL is of practical concern since concentrations approaching the UEL are not expected based on the equilibrium concentrations of H₂S in the vapour. Fig. 2 depicts the LEL of H₂S as a function of temperature². Note that more recent literature data on the LEL of H₂S differs slightly from the figure (e.g., at 330°F/166°C, the newer data indicates the LEL of H₂S is ~3 vol-% H₂S)⁹.

If a fire is ignited, the molten sulphur itself can serve as fuel. In addition, elemental sulphur has a flash point as low as 334°F/168°C². If the sulphur handling equipment is operated above the flash temperature, the risk of fires increases significantly. Furthermore, the auto-ignition temperature of elemental sulphur is

as low as 450°F/232°C¹⁰. While this is well above the normal operating temperature of molten sulphur storage systems, localised hot spots approaching the auto-ignition temperature could be a source of fires. Fig. 3 depicts the operating window for molten sulphur given its unique properties.

Finally, NFPA-655 cites 309°F/154°C as a transition temperature for the design of molten sulphur storage equipment. Above 309°F, additional design requirements apply (e.g., deflagration vents)¹¹. Field experience reported in the literature¹² and Trimeric's first-hand knowledge of operator experience supports the implication that bulk temperatures above 309°F are associated with increased frequency of sulphur fires, even though this is well below the sulphur vapour flash point.

Ignition sources

For sulphur below its auto-ignition temperature but within its flammability window, fires nominally require an ignition source. In molten sulphur applications, ignition sources include:

- **Static discharge accumulated by free-falling sulphur^{2,12}:** Molten sulphur is an electrical insulator and can accumulate static charge when falling through air. This leads to a risk of electrostatic discharge that can serve as an ignition source.

Fig. 1: Molten sulphur storage and handling system with tank sweep gas at sulphur production site

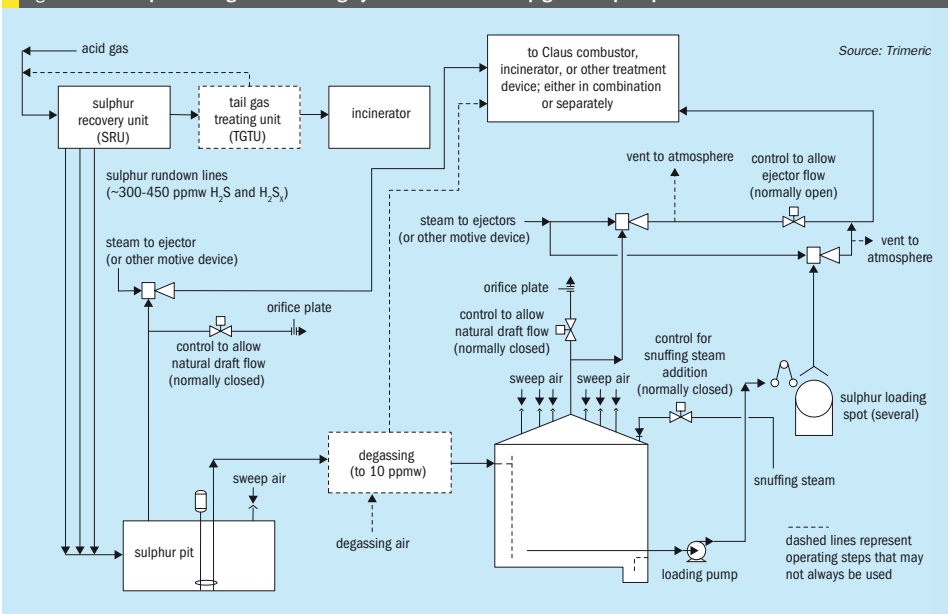

Fig. 2: LEL of H₂S as a function of temperature

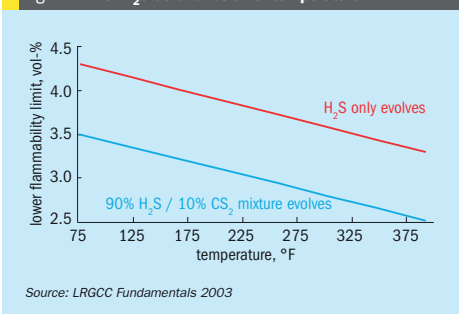
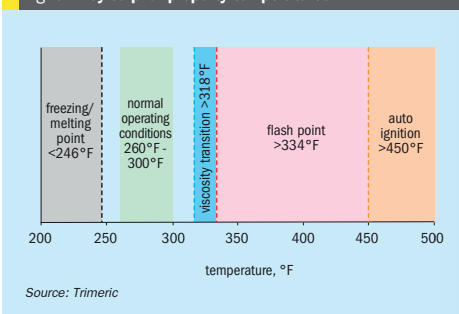

Fig. 3: Key sulphur property temperatures



(Note that, while the authors are not aware of any incidents where air moving over a stagnant molten sulphur surface (e.g., sweep air in a tank) have led to sulphur fires, the mechanism for static charge generation is similar to free-falling sulphur (i.e., relative velocity and associated friction between the air and the molten sulphur). Therefore, some have hypothesised that air sweeps over molten sulphur could pose a static discharge risk¹².)

- **Hot surfaces in equipment:** Rotating equipment may be susceptible. For example, failing pump bearings may lead to increased friction and localised hot spots.
- **Improper operating temperature:** This can occur from improper temperature design targets (e.g., operating above 309°F) or improper use of heating medium in storage applications (e.g., using steam with a temperature above the flash point of sulphur, i.e., above ~80 psig/~5.5 barg, if saturated steam is used).

General ignition sources in an operating facility, e.g., sparks generated by maintenance work, also pose a risk and must be considered in sulphur handling areas.

Pyrophoric iron sulphide formation

The formation of pyrophoric iron sulphide is a unique risk that exists in carbon steel equipment where H₂S and/or elemental sulphur and water are present in an anaerobic or reducing environment¹³. For example, in a carbon steel molten sulphur tank

Fig. 4: Formation of pyrophoric iron sulphide

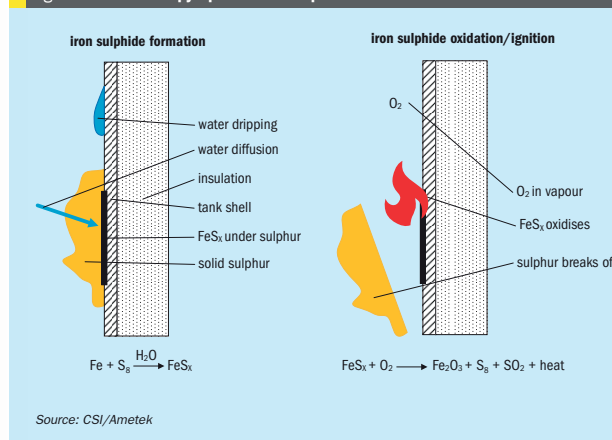

that is purged or blanketed with an inert gas (e.g., nitrogen), iron sulphide can form on internal tank surfaces. When water is present (e.g., via steam leaks), corrosion of carbon steel occurs yielding iron sulphide on the tank surface¹⁴ (see ref 14 for chemistry discussion). The iron sulphide does not present a risk on its own. However, if iron sulphide is exposed to oxygen (e.g., via air during tank maintenance), a pyrophoric reaction can lead to fires and/or explosions. In molten sulphur handling systems with sweep air, iron sulphide that is formed is generally oxidised quickly in a controlled manner, preventing accumulation to levels where the pyrophoric reactions can occur. However, even in systems with continuous air sweep, if significant deposits of solid sulphur accumulate on tank surfaces, it may limit access of the oxygen to the tank surface, allowing iron sulphide to form and accumulate (Fig. 4¹⁵). Therefore, internal tank surfaces that accumulate solid sulphur deposits are a safety concern.

Fire prevention

Industry standards and guidance

NFPA-655 ("Standard for Prevention of Sulfur Fires and Explosions") is a primary industry reference for fire prevention in molten sulphur handling applications. Chapters 5 and 6 (2017 edition) are related to molten ("liquid") sulphur handling. Chapter 5 applies to NFPA-defined normal handling temperatures (246°F-309°F). Chapter 6 applies to sulphur above 309°F. NFPA-655

includes guidance on the following preventative measures:

- Design for normal handling temperatures
 - Detection of unsafe conditions (e.g., H₂S monitoring)
 - Equipment design (e.g., tank feed/fill line extension to tank bottom to minimise free-fall and agitation when feeding sulphur)
 - Vent systems (e.g., heated vent system design to prevent molten sulphur solidification)
 - Bonding and grounding (e.g., bonding and grounding of sulphur lines, tanks, loading trucks/cars)
 - Open flames/sparks (e.g., appropriate conditions for activities involving open flames/sparks such as welding).
- Design for handling temperatures above 309°F
 - All of the guidance for normal handling temperatures apply.
 - Equipment design: Recommends design of equipment to be "closed as tightly as possible to prevent escape of vapour and to exclude air", signaling a different approach to fire prevention than sweeping with air to stay below the LEL.
 - Deflagration venting: Refers to NFPA 68 for deflagration venting design and covers other design considerations associated with deflagration vents (heating of vents/ducts, need for an inerting agent, etc.).

In addition to NFPA-655, NFPA-68 is relevant for deflagration venting and NFPA-69 (Standard on Explosion Prevention Systems) includes information on preventing and managing explosions/deflagrations. NFPA-69 identifies two approaches to prevent combustion: i) Combustible concentration reduction, ii) Oxidant concentration reduction. The standard provides a discussion on each approach (Chapter 7, 8, and Annex B in 2018 Edition).

Minimising combustible component concentration - Use of sweep gas

Sweep gas is often used to dilute the H₂S concentration in the vapour space of storage equipment. Different sweep gases have been used including air, nitrogen, fuel gas, steam, combustion product gases, and CO₂. Many molten sulphur storage tanks are swept with air because it is readily available and inexpensive. The flammability concerns with air (oxygen) can be mitigated by maintaining a safe margin below the LEL and installing monitoring equipment. Using 25% of the LEL is a common industry practice for calculating the sweep air flow rate requirement; values as low as 15%¹⁶ and as high as 35%¹¹ as an upper limit to stop operation have been reported. The presence of oxygen also keeps the tank atmosphere in an oxidising state, which prevents the formation of pyrophoric iron sulphide.

Other sweep gases (e.g., nitrogen, fuel gas, steam) have been used but are not as common because of the risk of pyrophoric iron sulphide formation, limited availability of the gas, and introduction of combustible materials to the tank, among other reasons. Details of the sweep gas approach are presented elsewhere^{17,18,19}. See the September-October 2020 issue of *Sulphur* for more details on sweeping and blanketing of gases¹⁸.

Minimising oxidant concentration - Inert gas blanketing

Another method to prevent fires and explosions in sulphur tanks is to blanket the tank with inert gas to limit the oxygen content in the vapour space by preventing air ingress. As shown in Fig. 5, the blanket gas (e.g., nitrogen) is fed to or removed from the tank to maintain a constant, slightly positive, pressure as inbreathing or outbreathing occurs (primarily via liquid movement). The flow of N₂ in "blanket" mode is intermittent and typically less than the gas requirement in "sweep" mode. The

Fig. 5: Example molten sulphur tank configurations with sweep air and inert gas blanket

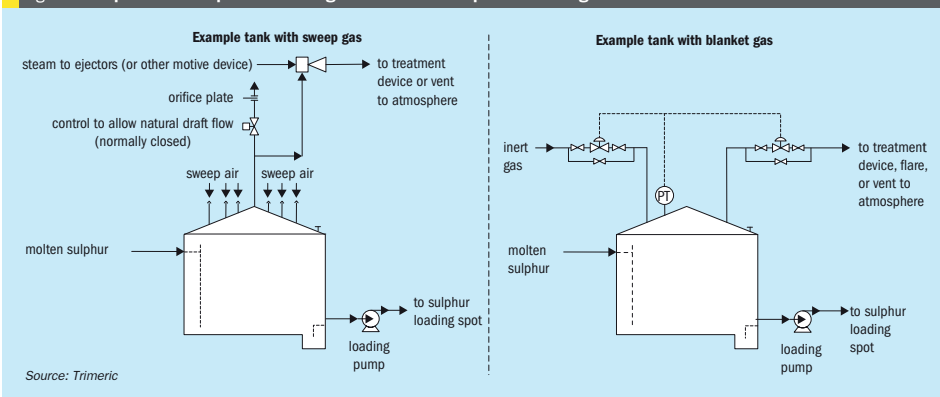

Source: Trimeric

blanketing method may be used if a site does not have the means to handle and/or treat the large continuous sweep gas flow. However, inert gas blanketing can result in a significant amount of H₂S accumulating in the vapour space that can create an explosion hazard if oxygen is unintentionally introduced to the tank. Inert gas blanketing also results in increased formation of pyrophoric iron sulphide, and a source of the inert gas is required. For these reasons, the use of inert gas blanketing to prevent molten sulphur tank explosions is less common than the use of air sweep. Another blanketing technique using gas with oxygen below the limiting oxygen concentration (LOC) is also presented in the literature^{16,18,20,21,22}.

Fire prevention and detection design features

The design of the molten sulphur pit or tank should include features to mitigate and detect sulphur fires such as those in Table 1.

Fire suppression

Industry standards and guidance

NFPA-655 is a primary standard for fire suppression in molten sulphur handling operations. In the 2017 edition¹¹, Chapter 5 (normal handling temperatures, 246-309°F/119-154°C) and Chapter 6 (handling sulphur above 309°F) contain relevant information on fire suppression. The box to the right summarises some of the fire suppression topics covered in the standard (2017 edition)¹¹.

Fire suppression industry standards and guidance

1. Firefighting methods (Section 5.5 in NFPA-655) for covered liquid sulphur storage tanks, pits, and trenches:

- Inert gas system designed according to NFPA 69.
- Steam extinguishing system capable of delivering a minimum of 2.5 lb/min of steam per 100 ft³ of volume ("snuffing steam").
 - In Annex A (Section A.5.5.1(2)), a design recommendation that snuffing steam "should be preferably introduced near the surface of the molten sulphur" (via NFPA 86, Section F.3).
- Rapid sealing of the enclosure
 - The only rapid sealing method explicitly discussed in the current NFPA-655 standard is sealing steam application (Annex A, Section A.5.5.1(3)).
 - Sealing steam is applicable to enclosed sulphur tanks or pits designed with sweep air systems that meet the requirements of NFPA 69. Steam delivered at a minimum rate of 1 lb/min per 100 ft³ of tank or pit volume is "expected to develop a positive pressure in the enclosure, thereby sealing the sulphur tank or sulphur pit and preventing air ingress and extinguishing the fire."
 - The standard includes additional guidance on sealing steam, referencing the originating literature²³.
 - The standard does not specifically exclude other means of "rapid sealing", including closing off vessel inlets and outlets.
 - Prior versions of NFPA-655 did explicitly refer to "...closing the container to exclude air..."; there was also language referring to small vessel sizes for this practice²⁴.
 - In the authors' opinion, extreme caution is advised regarding mechanical sealing of a vessel as a fire mitigation technique.

2. For open containers, fine water sprays are deemed acceptable for fire extinguishing.

3. For storage equipment operating above 309°F:

The standard indicates that storage equipment should be designed to exclude air under normal operation, so sealing methods for fire suppression are not applicable. The standard does indicate that an "adequate" supply of an inerting agent, such as steam, must be available "at all times for blanketing and purging equipment." ■

Table 1: Fire prevention and detection methods

Measurement	Description	Measurement locations	Other notes
Vapour space temperature (detection)	Temperature increase in tank or pit vapour space to detect localised fires.	Near the suction line of the motive device (temperature leaving the vessel) ²³ . Suspected stagnant zones in headspace (determined by CFD/other means) where temperature changes are readily observed ²³ .	Rate-of-temperature-increase alarm can be used. Literature data ²³ suggest ~2°F/min to ~5°F/min temperature rise indicate fires. Alarms can shut down air sweep to limit air ingress.
SO ₂ analyser (detection)	SO ₂ concentration increase in vent system indicates fire.	Vent system piping from tank or pit (location dependent on system design).	SO ₂ measurements in SRU incinerator stack have been used to detect pit fires ²³ . Ejector remained in operation to send vent gas to incinerator. 15-minute steam injection returned SO ₂ to normal baseline. Vapour space temperature measurements rose only 50-60°F (likely localised fires).
H ₂ S analyser (prevention)	H ₂ S vapour concentration > 25% of LEL indicates fire risk.	Tank/pit headspace and or vent system (location dependent on system design).	
Air flow (prevention)	Reduced air flow (vs. design) may indicate risk of flammable conditions in tank headspace.	Tank/pit air inlets or vent stack.	Low air flow can result from plugging, reverse flow through intakes. Low flow at some inlets can also result in uneven distribution of air, creating risk of localised high H ₂ S concentration.
Visual detection (detection)	Yellow plume from vent can indicate active fire.	Tank/pit vent.	

Source: Trimeric

Snuffing and sealing steam

NFPA-655 makes a distinction between snuffing and sealing steam. Snuffing steam is used to directly extinguish a fire by displacing air at the fuel-fire interface with steam, removing the oxygen needed for combustion. Sealing steam is used to effectively "seal" the tank/pit by continuously introducing steam to the headspace and generating a positive pressure in the vessel. This prevents additional air ingress, extinguishing the fire after any oxygen in the headspace is consumed.

The addition of "sealing" (as opposed to "snuffing") steam in NFPA-655 was based on the overpressure risk for typical air-swept tank and pit designs subject to the snuffing steam requirement²³. Analyses indicated that the snuffing steam requirement of 2.5 lb/min/100 ft³ of tank volume was often impractical to vent from air swept tanks and pits when balancing overpressure risk from the steam (large air inlets required to vent steam) against normal air intake (smaller inlets to prevent reverse flow)²³. A lower sealing steam rate (1 lb/min/100 ft³) was proposed based on industry feedback and steam flow evaluation via CFD.

Design and operating considerations

Sealing and snuffing steam systems have several considerations outside of the fire suppression function/flow requirements. Key design considerations include:

- **Location of the steam activation valve:** Industry practice is that the valve (typically manual) should be at least 50 ft from the tank (radially) to ensure the valve operator is safely removed from the hazard area^{23,3}. The valve should be located in a place where the operator has a clear line of sight from the valve to the tank vent(s) to verify steam activation.
- **Verification of dry steam:** The design should include provisions for blowdown of steam prior to activation to ensure only dry steam is present in the line. Wet steam can create a tank rupture risk (larger mass of water reaches and vaporises/expands in the tank). The steam system should include a drip leg and steam trap upstream of the valve to ensure condensate does not accumulate in the line and the line stays warm²³.
- **Minimise the risk of plugging:** To prevent sulphur plugging of the steam line,

the line may have rupture disks at the tank. Alternatively, the line can use a small purge gas flow to prevent back flow of sulphur vapour and/or be thoroughly steam jacketed or traced to prevent plugging. The sealing steam line operation should be verified periodically to ensure plugging has not occurred.

- Some references also indicate that sealing steam should be introduced close to air inlet nozzles so that the steam rapidly exits via the air inlets^{11,23}. In practice, if sufficient steam is introduced to generate positive pressure in the tank (i.e., force tank vapour out of the air inlets), the sealing effect of the steam should still be effective even if the vapour that initially leaves the inlets is headspace vapour (rather than steam). However, benefits of having the steam leave rapidly to form the "seal" may include:
 - Limiting the rapid expulsion of the toxic headspace vapours to the atmosphere and immediate vicinity as the steam enters.
 - Quick visual verification that the steam has reached the tank (exiting the air inlets).

(Note: It is important to distinguish between sealing steam, where it is recommended to introduce the steam near the air inlet nozzles and snuffing steam, where it is recommended (in NFPA-655) to introduce the steam close to the molten sulphur surface. The difference in the primary mechanism to extinguish the fire for each application explains the different recommendations for steam introduction.)

While the NFPA guidance for sealing or snuffing steam flow can be used directly as the basis for a steam fire suppression system design, several independent engineering checks can be performed to validate the steam rate (NFPA recommended or other steam rate):

- Verify positive pressure generated by the steam is sufficient to "seal" the tank/pit across a range of operating conditions (normal air sweep flow, air forced into the tank by wind effects, etc.).
- Check over-pressure risk once the maximum possible steam flow is finalised.
- Use CFD analysis to confirm adequate performance of sealing steam.

In Trimeric's experience, some sites do not have enough steam to supply the 1 lb/min/100 ft³ sealing steam as recommended in NFPA-655. Literature suggests that fires can be suppressed even if the steam rate is lower than in NFPA-655²³, and Trimeric's contacts in industry also indicate that lower steam rates are successfully used to extinguish fires.

Finally, time to steam activation after fire detection is another important design consideration to prevent fire damage. The authors' experience and some of the available literature^{23,25} suggest that operators have activated steam within ~4 to ~10 minutes of detecting a fire. The data also suggest that the pits and tanks often suffered no known damage, sometimes in spite of multiple fires. However, the duration of steam application to ensure complete extinguishing may vary greatly depending on many site-specific factors.

Mechanical sealing

Mechanically closing/sealing off all vents and air inlets is another approach to extinguish a tank or pit fire^{26,27}. This can be done using control valves that are activated remotely by an operator or automated in response to an alarm (e.g., high vapour space temperature) that indicates a fire. By stopping air ingress into the pit or the tank, the fire will put itself out once the oxygen reaches its LOC for combustion of sulphur.

This method may be considered if sufficient snuffing or sealing steam is unavailable.

However, a concern with mechanical sealing is heat generation in the closed vessel. Estimating the temperature and pressure produced by a fire in a sealed tank is complicated. The combustion of sulphur can be rather slow. There is also a large thermal mass from the molten sulphur and tank walls that can absorb the heat generated from combustion. In an extremely fast fire, combustion heat may only impact the headspace of the tank. In a very slow fire, combustion heat may be dispersed through the tank and its contents at the same temperature. The results of a simple analysis evaluating the total potential heat-up to reduce oxygen content below the LOC are shown below for an example tank:

- Fast combustion (heat absorbed by tank headspace and impacts gas temperature only): Tank headspace heats to >2,000°F/1,093°C with >30 psi/>2 bar increase, if not relieved.
- Slow combustion (heat absorbed by entire tank and all contents at equal temperature): Temperature of all contents rise by ~10°F with a pressure increase of 0.1 psi/0.007 bar.

The actual conditions may fall between the two extremes depending on operating conditions and the mechanisms of the fire. It may be prudent to design for the extreme cases. Damage to the tank could be severe, resulting in a loss of mechanical integrity or even collapse of the structure or roof. Overpressure and vacuum relief devices are important to relieve pressure build-up from heating and vacuum that could occur with cooling. Explosion hatches may also be warranted. The system will need to be allowed to cool below 309°F before reopening. Extreme caution is advised with this fire suppression method. If steam can be used, it may be a more effective and lower risk means to extinguish a fire^{26,27}.

Water mist

Spraying a solid stream of water onto a fire may cause the generation of a large amount of steam or cause sulphur (perhaps burning sulphur) to be splashed wildly. The sudden generation of steam in an enclosed space may result in overpressure of the tank or pit. However, water spray methods have been used to control sulphur fires on merchant sulphur vessels²⁸ and in sulphur production and manufacturing industries²⁹. Also, NFPA-655 recognises the use of a fine water spray to extinguish liquid sulphur fires stored in

open containers. Although Trimeric knows from experience that water sprays have been used to suppress fires in enclosed tanks, NFPA-655 does not mention using a water spray in enclosed tanks¹¹.

If the proper amount of water is used, the water mist option functions similarly to sealing steam, because the mist would vaporise to make steam. The water should be provided in a fine mist (as opposed to high-pressure water streams) to avoid splashing and provide good dispersion. The nozzles and spray headers that supply the water mist must be prevented from plugging. There are no known engineering standards for this molten sulphur fire suppression method, so careful design considering each system and situation must be applied.

Conclusions

Sulphur storage tanks and pits can be designed and operated to prevent, detect, and/or mitigate fires and explosions. Preventative methods include maintaining proper operating temperatures, preventing iron sulphide accumulation, limiting ignition sources, and maintaining the vapour space below 25% of the LEL of H₂S via sweep air or inert gas blanketing to exclude air. If a fire occurs, vapour space temperature, SO₂ concentration, and visual detection (plume) can be used to detect fires. The most common method used is to extinguish the fire is to provide snuffing or sealing steam to the tank, with careful consideration of overpressure risks from steam addition. Rapid sealing of the tank by closing the vents has also been used, but can result in high temperatures and overpressure or vacuum conditions that can damage the tank unless properly relieved. Direct contact with a solid stream of water is not recommended, but the use of a fine water spray has been used to suppress fires. Fire prevention and suppression methods may be dictated by site-specific constraints and local regulatory requirements. ■

Acknowledgement

This article is based on material prepared for the 2020 Brimstone Sulphur Recovery Symposium¹ and edited for *Sulphur* magazine.

References

1. Sachde D.J., McIntush K.E., Beitler C.A.M. and Mamrosh D.L.: "Preventing or extinguishing molten sulfur tank and pit fires," in Brimstone Sulphur Recovery Symposium, Virtual (2020).
2. Johnson J. and Hatcher N.: "Hazards of molten sulfur storage and handling," in Proceedings of the 53rd Annual Laurence Reid Gas Conditioning Conference, Norman, OK (2003).

3. McIntush K. et al.: "Molten sulfur storage tank, loading, and vapour ejection systems review," in Brimstone Sulphur Recovery Symposium, Vail (2015).
4. Lagas J., Butlin C., Fitzpatrick E., Wetzels M. and Kijlstra W.: "Understanding the formation of and handling of H₂S and SO₂ emissions from liquid sulphur during storage and transportation," in Sulphur Seminar, Amsterdam (1999).
5. Fenderson S.: "D'GAASS sulfur degasification sulfur update," in Brimstone Sulphur Recovery Symposium, Vail, Colorado (2005).
6. AFPM, "AFPM Process Safety Bulletin: Flammability hazards of hydrogen sulfide (H₂S) accumulation in sulfur tanks," American Fuel & Petrochemical Manufacturers (AFPM), Washington D.C. (2018).
7. Steudel R., Steudel Y. and Wong M.W.: "Speciation and thermodynamics of sulfur vapor," in Elemental Sulfur and Sulfur Rich Compounds I, Berlin, Springer Berlin Heidelberg, pp. 117-134 (2003).
8. McIntush K., Mamrosh D., Sachde D., Beitler C.: "Use of caustic scrubbers on vent streams from molten sulfur storage and shipping equipment," in Brimstone Sulphur Recovery Symposium, Vail, CO (2017).
9. Pahl R. and Holtappels K.: "Explosions limits of H₂S/CO₂/air and H₂S/N₂/air," Chemical Engineering & Technology, vol. 28, no. 7, pp. 746-749 (2005).
10. ConocoPhillips, Sulphur, Liquid (Canada) – Safety Data Sheet, Calgary: ConocoPhillips (2012).
11. National Fire Protection Association (NFPA), "NFPA 655: Standard for prevention of sulfur fires and explosions," NFPA, Quincy, MA (2017).
12. Bisila P.: "ABPG lessons learned: Molten sulfur reliability issues and solutions," in Brimstone Sulphur Recovery Symposium, Vail, CO (2014).
13. AFPM, "AFPM process safety bulletin: Hazards of purged tanks – Formation of pyrophoric iron sulfide in low oxygen environments," American Fuel & Petrochemical Manufacturers, Washington D.C. (2014).
14. Clark P.D. and Dowling N.: "Corrosion due to elemental sulfur in sour gas production and claus sulfur recovery systems," in MESPON 2016, Abu Dhabi, UAE (2016).
15. Forbes B. and Cipriano D.: "Case study of corrosion rates of an externally heated sulfur storage tank," in Brimstone Sulphur Symposium, Vail, CO (2018).
16. Chow T. and Flood T.: "Emissions reduction: Handling sulfur pit vents and sulfur storage tank vents," in Brimstone Sulphur Recovery Symposium, Vail, CO (2006).
17. McIntush K.E., Sachde D. and Beitler C.A.M.: "Molten sulfur vent stream disposition – Vent stream routing, managing emissions, and impact of process conditions/equipment," in Brimstone Sulphur Recovery Symposium, Vail, Colorado (2019).
18. Sachde D., Beitler C., McIntush K. and Fisher K.: "Preventing explosions in molten sulphur tanks," Sulphur Magazine, Issue no. 390, pp. 52-60 (Sep/Oct 2020).
19. McIntush K.E., Fisher K., Sachde D. and Beitler C.A.M.: "Design considerations for natural draft ventilation in molten sulfur storage tanks," in Brimstone Sulphur Symposium, Vail, CO (2018).

20. Affens W.: "Can pyrophoric materials form in oil tankers with inert gas fire protection systems?," NRL (1977).
21. Wankhede A.: "Marine Insight," 2020. [Online]. Available: www.marineinsight.com/marine-safety/protection-against-explosion-the-ig-system. [Accessed 14 August 2020].
22. Welch B.: "ABPG lessons learned: understanding iron sulfide and its pyrophoric nature," in Brimstone Sulphur Recovery Symposium, Vail, CO (2016).
23. Mosher A.D., McGuffie S.M. and Martens D.H.: "Molten sulfur fire sealing steam requirements: Proposed modifications to NFPA 655," in Brimstone Sulphur Symposium, Vail, CO (2015).
24. Texas Gulf Sulphur Company, TGS (Texas Gulf Sulphur Company) Sulphur Manual, New York: Texas Gulf Sulphur Company (1959).
25. Stern L.: "ABPG – Brimstone Sulphur Symposium, Vail – 2017," in Brimstone Sulphur Recovery Symposium, Vail, CO (2017).
26. DKL Engineering, Inc., "Sulphuric Acid Plant Safety," 2 November 2003. [Online]. Available: <http://www.sulphuric-acid.com/> [Accessed 2 September 2020].
27. Occupational Safety and Health Service, "Approved code of practice for the prevention of sulphur fires and explosions," Department of Labour, Wellington, New Zealand (1993).
28. Johnson L.: "Sulphur vessels," in Gulf Coast Section Meeting of the Society of Naval Architects and Marine Engineers, Houston (1972).
29. Georgia Gulf Sulphur Corporation, "Sulphur Fires," 2015. [Online]. Available: <https://georgiagulf.com/safety/sulphur-fires>. [Accessed 2 September 2020].



CHEMETICS®

Radial Flow Stainless Steel Converters

Experience:

- Originally developed and patented by Chemetics in 1981
- Industry standard best in class design
- More than 50 designed, fabricated and supplied by Chemetics

Features and Benefits:

- Radial flow design
 - Uniform gas distribution results in optimal catalyst performance
- All welded, contoured separation and support elements
 - Eliminates gas bypassing
 - Low mechanical stress design uses up to 30% less stainless steel
- No "Posts and Grates" for ease of access and catalyst installation
- Round gas nozzles eliminates leaks, over 1000 years of leak free operation
- Modular construction options to reduce cost and schedule risk
- Flexible configurations, such as internal heat exchangers, for easy retrofits.

Innovative solutions for your Sulphuric Acid Plant needs

Chemetics Inc.
(headquarters)
Vancouver, British Columbia, Canada
Tel: +1.604.734.1200 Fax: +1.604.734.0340
email: Chemetics.info@worley.com

www.worley.com/chemetics

Chemetics Inc.
(fabrication facility)
Pickering, Ontario, Canada
Tel: +1.905.619.5200 Fax: +1.905.619.5345
email: Chemetics.equipment@worley.com

Chemetics Inc., a Worley company

CONTENTS

What's in issue 392

COVER FEATURE 1

Sulphur and plant health

COVER FEATURE 2

Canada's sulphur industry

COVER FEATURE 3

New sulphuric acid catalysts

COVER FEATURE 4

The water side of SRUs

SULPHUR
ISSUE 392
JANUARY-FEBRUARY 2021

BCInsight

Southbank House, Black Prince Road
London SE1 7SJ, England

Tel: +44 (0)20 7793 2567

Fax: +44 (0)20 7793 2577

Web: www.bcinsight.com
www.bcinsightsearch.com

Hidden opportunity: the water side of sulphur recovery units

Failure investigations, equipment design and process upgrade projects for SRUs often overlook the impact of water quality. In this article **E. Nasato** of Nasato Consulting and **L. Huchler** of MarTech Systems explore impacts of higher heat transfer rates, control of boiler and condenser water chemistry, conventional equipment design/configurations and monitoring program designs. SRU operators can improve the effectiveness of their failure investigations by implementing a broader, more holistic approach that assesses equipment design, process conditions, operating protocols and water quality issues.

During the last several decades, most of the focus to improve the efficiency and capacity of sulphur recovery units (SRUs) has been on the process side: raising the operating pressure to generate higher-value, higher-temperature steam and increasing the process-side temperatures to increase throughput. As refineries implemented process upgrades such as oxygen enrichment in existing assets, the higher heat flux sometimes caused unexpected failures in the waste heat boiler (WHB) and condensers during normal operation and shutdown. Recent technical publications have described

water-related issues as root causes and/or contributing factors to these failures, including inadequate distribution of boiler feed water, steam blanketing on the boiler tubes, and water-side fouling and corrosion. More importantly, this article describes solutions that address changes in design and operation of both the process side and the water side.

Background

In recent years there have been several published papers describing failures of SRU WHBs and identifying the key design

and operating considerations to maximise the operability and reliability of the WHB. Many of the design and operating solutions are water-side issues: water chemistry, water circulation, heat flux on the water side, and impacts of commissioning, shutdown and layup on the reliability of the water side. It should be obvious that these water-side issues affect the downstream condensers. Because condensers produce low-pressure steam, water-side corrosion and fouling mechanisms progress more slowly. The message is clear: water-side failures in either the WHB or the condensers will create lost opportunity.

Fig. 1: Schematic flow diagram of a straight-through, 3 reactor, Claus SRU

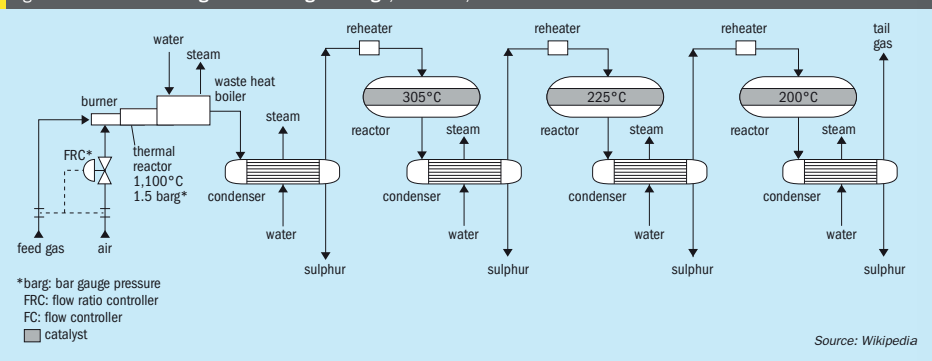

Fig. 2: Typical thermal reactor and two pass kettle WHB (Claus process SRU)

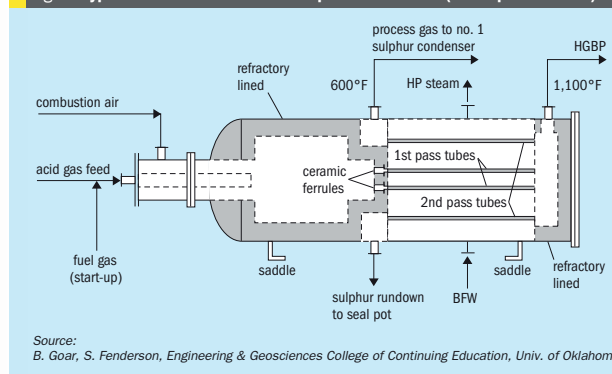
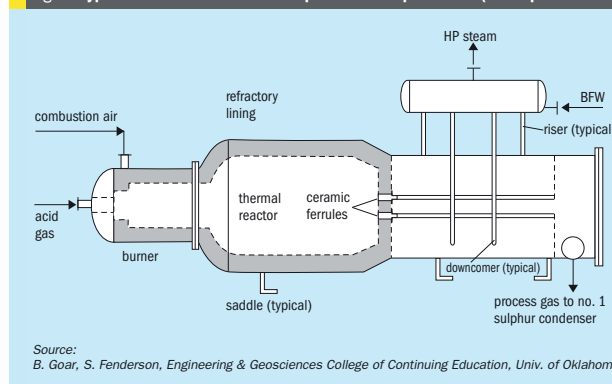

Fig. 3: Typical thermal reactor and two pass thermosiphon WHB (Claus process SRU)



Overview of SRU water side

The WHB generates steam from the waste heat of the high-temperature combustion of hydrogen sulphide-laden gas in the thermal reactor. The condensers also generate steam in a shell-and-tube heat exchanger to indirectly cool the process, recover useful energy in the form of low-pressure steam and precipitate elemental sulphur (Fig. 1).

The nominal operating pressure of a modern kettle and thermosiphon WHBs (Figs 2 and 3) is typically in the range of 450 to 600 psig (31 to 41 barg), with the boiler water on the shell side.

The nominal operating pressure of the condensers (Fig. 4) is in the range of 15 to 75 psig (1.0 to 5.2 barg), with the boiler water on the shell side.

The steam generators, WHB and condensers, share a common boiler feed water (BFW) supply. In the interest of simplicity, the addition of water treatment chemicals for corrosion and deposit control occurs upstream of all of these assets. The sulphur recovery process normally operates at a constant production rate. Consequently, these steam generating units also operate at steady-state. Operators routinely monitor the water chemistry of the BFW and the WHB boiler water (blowdown) and make adjustments to control the chemistry of this high-pressure steam generating unit. However, operators seldom monitor or make adjustments to control the chemistry of the condensers. Sometimes the water treatment supplier will sample and test the water chemistry of the condensers; however, usually the water side of these

condensers receives no attention until they have a failure.

WHB mechanical design considerations

In the past, WHBs generated low pressure steam; modern designs generate much higher steam pressure, creating mechanical design and operating challenges. As a result, WHB failures are becoming increasingly more common. There are several design considerations that can increase the reliability of WHBs.

All WHB design considerations:

- WHB tube diameter;
- WHB tube pitch;
- WHB tube wall thickness;
- tube-sheet thickness;
- materials of construction;
- welding techniques for the tube-to-tube-sheet welds;
- intermittent blowdown: number and location;
- continuous blowdown: location and collection lateral design;
- ferrule design and installation considerations.

Kettle design considerations:

- BFW location;
- BFW distributor design;
- steam outlet location;
- disengagement space design.

Thermosiphon design considerations:

- recirculation ratio;
- locations of risers and downcomers;
- steam drum design.

WHB operational issues

Safe operation of the WHB relies on effective cooling – transferring the heat from the hot gases in the tube side to the water in the shell side. Industry trends show that the water/steam-related shell-side failures are becoming the prevalent root cause of WHB failures. Experience with new WHBs confirms that equipment designers have not yet optimised the mechanical designs to prevent WHB failures. These water/steam-related failures provide harsh reminders of the importance of keen attention to address design issues in WHBs to ensure safe, reliable operation.

From a shell-side and water treatment perspective, the key items that have changed in the industry over time include:

Fig. 4: Typical straight shell condenser (Claus process SRU)

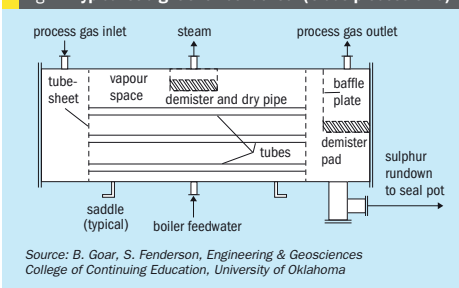

Source: B. Goar, S. Fenderson, *Engineering & Geosciences College of Continuing Education, University of Oklahoma*

Fig. 5: WHB regime vs carbon steel sulphidation temperature

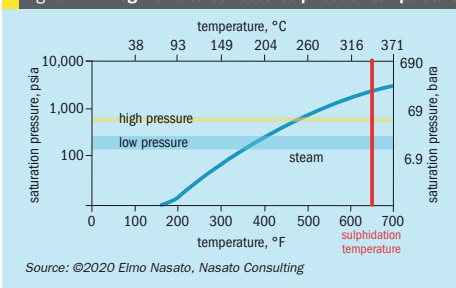

Source: ©2020 Elmo Nasato, Nasato Consulting

SRU operating pressures and temperatures (Table 1) and WHB operating pressure and oxygen-enrichment processes that increase heat flux. For kettle-style WHBs, the more stringent, high heat flux operating modes have resulted in failures attributed to poor water distribution and/or vapour disengagement issues.

The typical material of construction of a WHB is carbon steel. For these modern SRUs that have higher-pressure/high-temperature steam generation, there is a smaller margin of error to prevent the operating temperature of the water-side heat transfer surface of the WHB from reaching the sulphidation temperature. Improper water treatment that creates insulating deposits on the water-side heat transfer surfaces or equipment configurations that prevent adequate water flow create a risk of the shell-side exceeding the sulphidation temperature and causing catastrophic damage. This reduced margin increases the risks for SRUs that use natural gas during start-up and shutdown, especially in oxygen-enriched processes that have elevated operating temperatures. The higher operating temperature of the WHB steam-side has also presented new challenges to the WHB design and operation (Fig. 5).

Excessively high temperature affects the reliability of the WHB by degrading the tube sheet system that includes the refractory, ferrules, tubesheet, tube-to-tubesheet joint, and tubes. Thermal cycling as well as rapid changes in process and refractory temperatures are detrimental to the reliability of the WHB tubesheet system. Thermal cycling events might be a result of scheduled shutdowns; however, a more likely cause is sudden, unplanned shutdowns. Shutdowns cause thermal and mechanical stresses to the WHB equipment that may result in localised steam blanketing at the

Table 1: Summary of historical SRU designs

	Pre-1990 era	Post-1990 era
Pressure range, psig (barg)	150-250 (10-17)	450-600 (31-41)
Steam temperature, °F (°C)	354-399 (179-204)	457-484 (236-251)

hot end of the tubesheet. In well-designed systems, the thermal reactor and WHB has a thermal cycle life expectancy as high as 20 years; inadequate designs may have as low as two or three years of thermal cycle life expectancy. Obviously, damage to the tube sheet protection system causes a loss of system reliability.

Kettle vs thermosiphon WHB design

Field experience has shown that thermosiphon boilers are generally less vulnerable to failure than kettle-type steam generators. For high temperature applications, properly designed thermosiphon boilers provide the benefit of very high recirculation rates that creates a smaller temperature gradient across the tubesheet, reducing the risk of localised areas of high heat flux and non-nucleate boiling. The design of kettle reboilers must have a sufficiently large disengaging space to minimise the back pressure from the steam header and reduce the risk of steam blanketing on the tubes.

Preventing steam blanketing is the biggest challenge in the design and operation of WHBs. The tube pitch arrangement is critical, especially for thermal stage operating at high temperature processes such as oxygen-enrichment. A square pitch rotated at 45° creates less back pressure on the steam side of the tube bundle, resulting in more efficient vapour disengagement and a lower risk of steam blanketing. High temperature thermal stage operation (e.g. straight through ammonia destruction or oxygen-enriched operation) can reach temperatures

above 2,300°F (1,260°C), creating a dangerously high LMTD (log-mean temperature difference) in the WHB. This high steam-side flux result in approximately 50% of the steam generated in the first 25% of the boiler tube length. Clearly, it is important to calculate the profile of steam flux rates over the length of the WHB tubes to reduce the risk of damage from steam blanketing.

Heat flux is determined by the radiant contribution on the process gas side and the heat transfer coefficients on the process-gas side and the water side. Engineers can establish appropriate temperature and mass flux operating conditions to provide reliable service for a specific WHB design and study the limitations of heat flux in the turbulent region at the end of the ferrule to assess the ability of the tubesheet protection system to maintain “safe” metal temperatures. Frequently designers erroneously base the WHB design and evaluation exclusively on convective heat transfer; this approach ignores the contribution of radiant heat transfer. The radiation component can contribute up to 20% additional heat flux, creating a significant impact on the calculation of the surface area for the WHB and the piping design for the BFW and steam generation systems.

As the operating pressures of SRUs have increased, both thermosiphon and kettle-type WHBs have higher heat transfer coefficients. Higher heat transfer rates increase the need for proper mechanical design of feedwater inlet and distribution, steam separation/discharge, continuous

blowdown collection and intermittent blowdown systems. As described in the next section, it is imperative that the WHB process design ensures an adequate volume and flow of boiler feed water at the critical inlet tubesheet location. From an operational perspective, properly implemented intermittent blowdown may protect the tubes, especially in the location of highest steam flux near the inlet tubesheet.

Process upgrade – oxygen enrichment

Oxygen enrichment increases the sulphur production rate of an existing SRU. The WHB hydraulic profiles of the air-based and oxygen-enriched process are virtually identical; the tube mass flux and tube-side pressure drop values are identical for both modes of operation. The only difference is a requirement for flame moderation for high-level oxygen-enriched operation (Table 2).

Increasing the sulphur production rate increases the heat flux and the steam production rate in both the WHB and the condensers. More importantly, higher heat flux creates a risk of non-nucleate boiling in localised areas of inadequate water circulation – a dangerous phenomenon also known as steam blanketing.

An evaluation of the impact of oxygen enrichment on the WHB must include an analysis of the heat flux rates along the entire length of the tubes, especially at the highly turbulent area on the upstream side of the ferrule. The heat flux should not exceed 50% of maximum nucleate flux at design conditions, and 65% for maximum service conditions. These limits ensure that the temperature of the tube wall is within 18°F (10°C) of the saturation temperature at design, well below the 72°F (40°C) break-

Table 2: Summary of key input and calculated parameters of air-based and oxygen-enriched operation

	Air-based	35% Oxygen	70% Oxygen
Successful operation	yes	no	no
Tube size, inches (mm)	3.0 (75)	3.0 (75)	3.0 (75)
Inlet temperature, °F (°C)	2,354 (1,290)	2,597 (1,425)	2,795 (1,535)
Steam pressure, psig (barg)	650 (45)	650 (45)	650 (45)
Mass flux, lb/(ft ² -s) (kg/(m ² -s))	4.2 (20.5)	4.3 (21)	5.4 (26.7)
Maximum metal temperature at tube-to-tube-sheet weld, °F (°C)	547 (286)	561 (294)	590 (310)
Pressure drop, psi (bar)	0.38 (0.026)	0.38 (0.026)	0.42 (0.029)

over to Leidenfrost film boiling (exceedance of the critical maximum nucleate flux).

The tube-to-tube pitch diameter is critical to ensure proper evacuation of the produced steam. The practical recommendation for the design of steam generators is an overall heat flux of 20,000 Btu/(hr-ft²) (65,091 W/m²) for kettle-type boilers and 30,000 Btu/(hr-ft²) (94,637 W/m²) for thermosiphon boilers. The heat fluxes for the oxygen-enriched operations are much higher at the hot end of the tubesheet in the WHB (Fig. 6). The high steam generation rates in combination with the tight ligament causes overheating of the tube-to-tubesheet weld and creates a risk of failure.

Water-side control issues

Proper design and location of the BFW inlet and the continuous and intermittent blowdown connections can reduce the risk of localised areas of inadequate water circulation, off-spec water chemistry and steam blanketing in both the WHB and the condensers. Confirming the process capability for blowdown based on the feedwater quality and ensuring consistent and accurate level

control can reduce the risk of corrosion and fouling of heat transfer surfaces and steam blanketing, tube-thinning, carry-over and compromised continuous blowdown flow.

BFW Inlet

The location and configuration of the BFW inlet can have a dramatic effect on the circulation in both the boiler and the condensers. The most rudimentary BFW inlet consists of a transfer pipe that ends a few inches beyond the penetration of the wall of the pressure vessel, with perhaps a 90° turn to direct water along the longitudinal axis (Fig. 7).

A robust design for the BFW inlet is similar to the inlet lateral for a conventional water-tube fired boiler: a small-diameter pipe that extends the length of the steam drum at 12 o'clock (bottom of steam drum) with holes equally spaced along the entire length at the 12 o'clock position. CFD models map the thermal gradient for a WHB BFW inlet distributor properly installed (Fig. 8a) and improperly installed: rotated ~45 degrees (Fig. 8b). The thermal gradient in Fig. 8b compromises the steam generation process, creating a risk of localised low flow areas and

Fig. 6: Typical heat flux profiles of air-based and oxygen-enriched operation

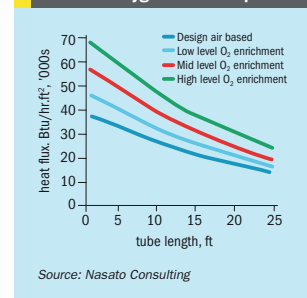

Source: Nasato Consulting

Fig. 7: WHB rudimentary boiler feedwater inlet

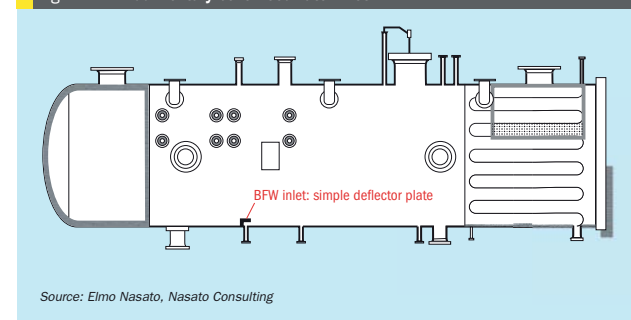

Source: Elmo Nasato, Nasato Consulting

Fig. 8a: BFW inlet distributor improperly installed, rotated 45°

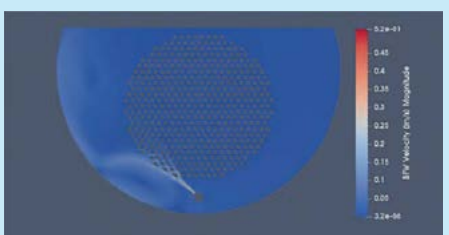

Source: Continuum Engineering/Nasato Consulting

Fig. 8b: BFW inlet distributor properly installed

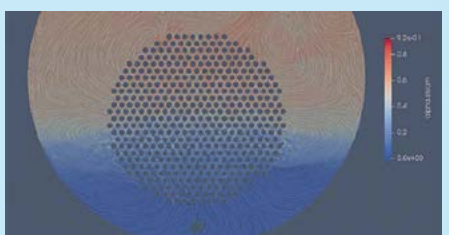

Source: Continuum Engineering/Nasato Consulting

poor evacuation of the steam/water mixture from a portion of the tube bundle.

A poorly-designed or improperly-installed BFW lateral compromises proper circulation, creating a risk of inadequate water circulation and off-spec water chemistry in both the WHB and the condensers.

Continuous blowdown

For a kettle-style steam generating WHB or condenser, the location of the continuous blowdown collection lateral is just below the water's surface where the concentration of dissolved solids is the highest. Continuous blowdown removes a portion of the concentrated boiler water and any low-density suspended solids floating on the water/steam interface. A robust design for the continuous blowdown collection lateral is similar to the inlet lateral for a conventional water tube fired boiler: a small-diameter pipe that extends the longitudinal length of the steam drum at an elevation just below the waterline with holes equally spaced along the entire length at the pipe (3 o'clock or 9 o'clock) position. Fig. 9 shows a continuous blowdown collection lateral on the left-hand side of the photograph.

Fig. 9: Inlet tubesheet with continuous blowdown collection



Fig. 10: FAC corrosion on bottom of tubes at the hot gas inlet



Intermittent blowdown

With softened water make-up, the purpose of routine, manual intermittent blowdown is to reduce the risk of deposits on heat transfer surfaces by removing the precipitated calcium-phosphate sludge formed in on the heat transfer surfaces. Most plants no longer conduct routine intermittent blowdown because the modern dispersants have eliminated precipitated sludge. For condensers that use high-purity water (reverse osmosis permeate, demineralised water, condensate), routine intermittent blowdown is not necessary; it wastes energy, water, and boiler water chemicals.

Sometimes designers mistakenly eliminate the intermittent blowdown connection in new SRU equipment. Non-routine intermittent blowdown is necessary to address process contamination of the boiler water or upsets in feedwater or boiler water chemistry. The need for intermittent blowdown may not always be obvious: leading indicators include extended periods of non-conforming water treatment, poor quality condensate, and unscheduled shutdown events.

Because modern boiler water treatment does not require routine intermittent

blowdown, most operators lack the training necessary to properly operate the manual intermittent blowdown valve. Operators must quickly open the valve to 100% for several seconds to allow the high velocity stream to move accumulated sludge and/or corrosion products followed by rapidly closing the valve to prevent discharging too much boiler water. In this era of Safety Instrumented Systems (SIS), the risk of not closing the valve quickly enough is huge: a low water level alarm will trigger a unit shutdown and route the combustible gases to the flare, a reportable event that may have environmental regulatory and legal consequences. Training operators to operate the intermittent blowdown control valve properly and safely will increase the reliability of the SRU and reduce the risk of an operator error.

Finally, the design of an intermittent blowdown system should ALWAYS have two valves in series: the specially designed "impulse flow" intermittent blowdown valve and a classic isolation valve. There is always a risk that a single valve will "fail open," tripping the unit and creating a major incident.

Blowdown valve sizing

Historically, the feedwater quality for sulphur recovery units is a mixture of sodium zeolite softened make-up water and condensate. When refineries began to install reverse osmosis (RO) units to create make-up water for fired and waste heat boilers, WHBs and condensers began to experience high rates of corrosion. Investigation revealed poor control of water chemistry due to high blowdown flowrates. The original blowdown valves for the larger flowrate of softened water make-up were oversized and not suitable for modulating the smaller flowrates for RO make-up. The mismatch between the valve size for softened water versus RO permeate is large; prior to installing smaller blowdown valves, operators were conducting blowdown by modulating the flow through the boiler water sample line. Astonishingly, equipment designers have continued to consistently size the blowdown valves in both WHB and condensers as if the make-up were softened water.

High purity make-up

Control of boiler chemistry is more critical and more difficult in steam generators that have high-purity feedwater (e.g. 100% condensate) than systems that use softened water as part or all of the feedwater. The lack of buffering in high-purity water requires more intensive monitoring and more precise control of water chemistry to "safe" specification limits to ensure reliable operation. WHBs and condensers using high purity make-up will have a high risk of flow-assisted-corrosion (FAC) when all of the following operating conditions are present:

- reducing conditions;
- high-purity water;

- highly turbulent boiler-water flow conditions in condensers.

The classic candidate for FAC is an SRU system that has high purity make-up water, uses an organic oxygen scavenger and has modified the sulphur recovery process to increase throughput. Fig. 10 shows FAC on at the 6 o'clock position (bottom) of the lowest row of tubes at the inlet tubesheet in the condenser.

Reducing one or more of these three operating conditions below the "critical" level will reduce and, at sufficiently low levels, eliminate FAC. Operators of SRUs with high purity make-up should note that conformance ASME guidelines are not sufficient to ensure reliable operation. The ASME guidelines do not specify limits for hydroxide ("OH") alkalinity; typically the chemical supplier specifies the minimum specification limits for boiler water alkalinity based on the boiler feed water quality, duty cycle and historical system reliability.

Some refineries that have high-purity feedwater have implemented coordinated pH/phosphate (PO₄) programs for their boiler and condenser water. A coordinated pH/PO₄ treatment program creates a buffering system for phosphate and caustic to avoid the risk in high purity boiler water of under-deposit corrosion damage from caustic concentrating under iron deposits (caustic gouging) on heat transfer surfaces. The risk of caustic gouging is very low for steam generating systems operating at or below 600 psig (31-41 barg) pressure; the risk increases dramatically for higher-pressure steam generators.

The key consideration is the return on investment for implementing coordinated pH/PO₄ treatment programs in the SRU. A separate chemical feed and control system

is required for the WHB, moderate-pressure condensers and low-pressure condensers because the chemical feed rate depends on the operating pressure of the steam generator. Controlling the coordinated pH/PO₄ treatment program is no small task; as the feedwater quality changes in pH (sodium concentration), operators must adjust both the chemical treatment feed rate as well as the blowdown. Finally, a coordinated pH/PO₄ treatment program is not very forgiving; failure to strictly conform to the specification limits creates a risk of caustic gouging. The bottom line: the complexity to control a coordinated pH/PO₄ treatment program in an SRU is not worth the benefit.

Refineries have proven that an SRU can operate reliably on either softened water make-up or high-purity boiler feedwater (BFW) provided that the chemical supplier recommends the correct chemical treatment program, the chemical feed and blowdown systems have sufficient process capability and the operators diligently monitor and make timely adjustments for chemical feed and blowdown rates.

Poor level control

The proper water level in the condenser is above the top row of tubes, an operating condition that maximises heat transfer and system reliability. Continuous, proper level control is critical for both WHB and condensers. With the adoption of safety instrumented systems (SIS) for these kinds of critical processes, plants have installed redundant measurement and control systems. Aging equipment, failure to conduct preventative maintenance and calibration, and operator error can be sources of poor level control.

Another source of poor level control is the design of some condensers: insufficient

Fig. 11: First condenser - tube thinning measurements.

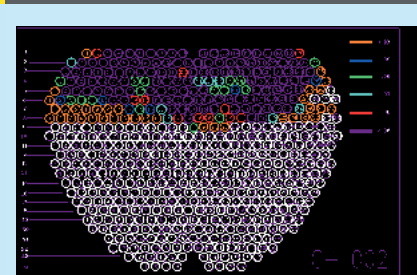

Source: Loraine Huchler, P.E., MarTech Systems, Inc.

Fig. 12: First condenser - historical water level

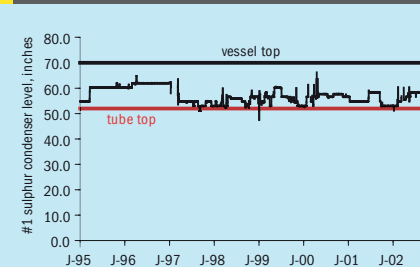

Source: Loraine Huchler, P.E., MarTech Systems, Inc.

disengagement space above the water level to prevent carryover into the receiving steam header. Operators can quickly recognise signs of carryover: decreasing steam temperature (and pressure) in the outlet steam header and, in severe cases, water leaking from flanges on the connection to the steam header. Typically, operators will take steps to minimise carryover by adjusting the setpoint on the level controller. Figs 11 and 12 confirm that when a plant does not have strict limits on the level controller, operators may inadvertently decrease the water level below the top tube row, creating a risk of steam-side burning and tube-thinning that leads to premature failure and unplanned outages.

It is difficult to document the exact water level; however, the data in Fig. 11 implies that some of the tubes in the top rows were exposed to steam some of the time and tubes at the steam-water interface were alternately exposed to boiler water and steam. In this plant, poor water treatment resulted in severe, irreversible fouling in the WHB and a loss of approximately 10% heat transfer efficiency, forcing the first condenser to operate at an average inlet process side temperature of 860°F during the period immediately prior to the failure (maximum OEM specification of 775°F). Not surprisingly, Fig. 12 shows widespread tube-thinning damage in this first condenser.

Some sulphur condensers have a steam separator (knock-out drum) located at the outlet to eliminate entrainment of boiler water in steam. This same refinery installed external steam separators on every condenser to prevent future premature failure of condenser tubes.

Water-side operating issues

The focus to improve the efficiency and capacity of the process side of the SRU for the last several decades has resulted in several clear trends: longer service runs, shorter turnaround periods, increased shutdown and commissioning activities for equipment retrofits for process upgrades. And the trend of increasing water-side failures in the WHBs is a direct result of these process upgrades and the absence of robust, effective failure investigations.

Longer service runs

Refineries have been increasing the interval between turnarounds as suppliers improve the reliability of process-side

components. Consequently, poor conformance and monitoring of water chemistry to ASME guidelines and/or poor compliance to the water treatment program specifications often becomes the limiting factor for the turnaround interval. For example, iron deposits on heat transfer surfaces in the WHB due to inadequate chemical treatment/poor blowdown control can cause a short or long term WHB tube failure. Minimising the risk that water-side issues will limit the interval between turnarounds requires an effective operating discipline for monitoring and control of the water chemistry within the specification limits and a commitment to maintain equipment such as blowdown control valves, boiler feedwater inlet distributors, continuous blowdown collection laterals, level controllers and steam separation equipment.

Shorter turnarounds

Water-related issues such as inspections and equipment modifications are often the lowest priority during turnarounds. All turnarounds have aggressive schedules and repairs that take longer than expected. Consequently, it's highly likely that the plant will not complete some water-related issues. Unfortunately, water-side problems not addressed during turnaround may become the limiting factor for reliable operation in the future. Analysing operating data and historical inspection reports to assess the impact of existing water-related issues on process-side efficiency may increase the priority of solving water-side problems during turnaround.

Failure investigations

After a failure, economics drive the pressure to return a unit to service. As an example, refinery staff will typically plug individual tubes in a WHB or condenser, because pulling the tube bundle and cutting a single tube sample, unless the tube happens to be in an outer location, is not feasible. Without metallurgical analyses, the only evidence might be photographs of the heat transfer surfaces from visual inspections that often fail to show the contour of the corrosion of the surface or corrosion within the tube bundle.

A more fundamental challenge to identifying water-related failure mechanisms is a lack of familiarity about the purpose and proper configuration of the internal components in the WHB and condensers. One plant had disconnected the inlet boiler feedwater lateral in all of the condensers

to allow them to lower the water level to reduce the frequency and degree of carry over.

The most ironic part of failure investigations is the unconscious bias towards process-related root causes. Typically, plant staff do not even consider water as a root cause or contributing factor. In one case, a refinery client had several SRU experts examine the photographs, model the process and test numerous hypotheses over the course of a year before asking the water treatment expert to review the data and properly identify the root cause – and the corrective action.

Commissioning

The greatest water-related risk during commissioning of an SRU is the hydrotest. Although there may be a procedure and a specification for water quality, the demands of the schedule and the inevitable delays typically result in a failure to promptly drain – or ever drain the hydrotest water. The resulting corrosion seldom causes a failure or permanent damage; however, the large quantities of iron corrosion products during start-up compromises the water quality and can create deposits on heat transfer surfaces that create risk of overheating or under-deposit corrosion and subsequent premature failure. There is another risk of an "off-spec" hydrotest: in the event of an equipment failure after hydrotest or shortly after commissioning, it will be difficult, if not impossible, to definitively identify the initiation of the root cause of the damage.

Shutdown/lay-up

Refineries seldom lay-up an SRU unless the refinery is completing repairs or installing equipment for a process upgrade. Shutdown occurs prior to every turnaround, at every failure and for emergencies such as a severe hurricane.

During controlled shutdowns, plant personnel must purge the residual sulphur gases. The classic "burn-out" procedure requires operation of the reheaters located at the outlet of the condensers and continuous circulation of the boiler water to cool the condenser tubes and prevent short-term overheating of the condenser tubes. Reviews of historical bulk gas temperatures at the reheater effluent show high temperature spikes during this "burn-out" procedure. Fig. 13 shows two temperature excursions for this "burn-out" procedure. These temperature excursions during

Fig. 13: Last condenser – process gas temperature

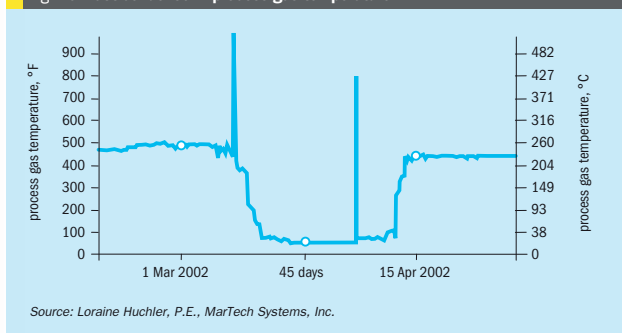

shutdown were severe enough to cause corrosion in all of the condensers, including the last condenser. Fig. 14 shows the top row of tubes at the hot tubesheet with corrosion at the 6 o'clock position.

This plant upgraded to oxygen-enrichment that increased the process temperatures. The additional heat causes a rapid increase in steaming rate, especially at areas of high metal mass such as the inlet tubesheet. A steam blanketing effect traps steam between the tubesheet and the tubes, insulating the water side of the tube surface from the cooling effects of the condenser water and causing localised "steam-side burning" or rapid oxidation of the steel tube surfaces. The patterns of the affected tubes are consistent with a trapped pocket of steam, causing more severe corrosion at the bottom of the highest affected row of tubes and on the sides of adjacent tubes in the bundles. This short-term temperature excursion occurred only in condensers that have upstream reheaters.

Fig. 14: Last condenser – corrosion on bottom of tubes at the hot tubesheet



PHOTO: LORAINÉ HUCHLER, P.E., MARTECH SYSTEMS, INC.

Fig. 15: Condenser inlet tubes – dissolved oxygen pitting during shutdown



PHOTO: LORAINÉ HUCHLER, P.E., MARTECH SYSTEMS, INC.

at the air/water interface. From a practical perspective, plant personnel should take steps to protect against the risk of dissolved oxygen corrosion if the system will have stagnant water for more than 24 hours. Options to manage the risk of corrosion include nitrogen blanketing or the addition of a volatile amine-based corrosion inhibitor.

Conclusion

Process upgrades, OEM design and operating protocols on the process side are inextricably linked to issues on the water side such as water chemistry, water treatment, blowdown valves, BFW inlet laterals. The objective is to build awareness for equipment designers, process design professionals, engineering firms, process engineers, operations staff, water treatment service representatives and consultants to embrace a broader, more holistic approach to evaluate root causes and identify contributing factors, to design equipment and processes, to operate plants, to monitor and control water treatment programs and to conduct failure investigations.

References

- van Son M., Scheel F., Lawrence C., Radovich S., Chow T., Pollitt S., Misale-Lyttle D. and Nasato E.: "Generic rules for robust SRU waste heat boiler design and long term reliable operation practices," Middle East Sulphur conference, Abu Dhabi (Feb 2017).
- Engelhardt N., Misale-Lyttle D. and Nasato E.: "Reliability of boiler tube protection systems – A Valero case history: Operation in air-based and oxygen enriched conditions," Brimstone Vail Sulphur Recovery Symposium (Sep 2017).

CONTENTS

What's in issue 392

COVER FEATURE 1

Sulphur and plant health

COVER FEATURE 2

Canada's sulphur industry

COVER FEATURE 3

New sulphuric acid catalysts

COVER FEATURE 4

The water side of SRUs

SULPHUR
ISSUE 392
JANUARY-FEBRUARY 2021

BCInsight

Southbank House, Black Prince Road
London SE1 7SJ, England

Tel: +44 (0)20 7793 2567

Fax: +44 (0)20 7793 2577

Web: www.bcinsight.com
www.bcinsightsearch.com

Advertisers' index

Editor: RICHARD HANDS
richard.hands@bcinsight.com

Technical Editor: LISA CONNOCK
lisa.connock@bcinsight.com

Contributor: MEENA CHAUHAN
meena.chauhan@argusmedia.com

Publishing Director: TINA FIRMAN
tina.firman@bcinsight.com

Subscription rates:
GBP 440; USD 880; EUR 680

Subscription claims:
Claims for non receipt of issues must be made within 3 months of the issue publication date.

Sales/Marketing/Subscriptions:
MARLENE VAZ
Tel: +44 (0)20 7793 2569
Fax: +44 (0)20 7793 2577
marlene.vaz@bcinsight.com
Cheques payable to BCInsight Ltd

Advertising enquiries:
TINA FIRMAN
tina.firman@bcinsight.com
Tel: +44 (0)20 7793 2567

Agents:
Japan: (also subscription enquiries)
KOICHI OGAWA
O.T.O. Research Corporation
Takeuchi Building
1-34-12 Takadanobaba
Shinjuku-Ku, Tokyo 169, Japan
Tel: +81 3 3208 7821
Fax: +81 3 3200 2889

Previous articles from *Sulphur* from 1995 to the present are available digitally in PDF format. To make a purchase, or for a list of available articles, please see: www.bcinsight.com

Copyright
Issued six times per year, or bi-monthly. All rights reserved. No part of this publication may be reproduced, stored in a retrieval system or transmitted in any form or by any means – electronic, mechanical, photocopying, recording or otherwise – without the prior written permission of the Copyright owner.

ISSN: 0039-4890

Design and production:
JOHN CREEK, DANI HART



Printed in England by:
Buxton Press Ltd
Palace Road, Buxton, Derbyshire,
SK17 6AE

© 2021 – BCInsight Ltd

BCInsight

Published by: BCInsight Ltd
China Works, Unit 102,
100 Black Prince Road,
London SE1 7SJ, UK
Tel: +44 (0)20 7793 2567
Fax: +44 (0)20 7793 2577
Web: www.bcinsight.com
www.bcinsightsearch.com

Advertiser	Page	Website
Ametek Process Instruments	25	ametek.com
Argus Media	11	argusmedia.com
AXENS	5	axens.net
BRIMSTECH CORPORATION	IBC	brimstech.com
Haldor Topsoe	15	topsoe.com
HUGO PETERSEN GmbH	OBC	hugo-petersen.de
IPCO Germany GmbH	9	ipco.com
Sharpflex Filters	19	sharpflex.com
Worley Chemetics	IFC	worley.com/chemetics
Worley Chemetics	45	worley.com/chemetics

Next issue: March/April 2021

- Phosphates – can China balance the market?
- Refining – dealing with the Covid crisis
- Canada's sulphur industry
- Sulphuric acid catalysts
- Solving operational problems in the SRU with simulation
- Preventing or extinguishing molten sulphur tank and pit fires

Closing date for advertisement space booking is 8 March 2021
For further information and to book advertisement space contact:
Tina Firman, Publishing Director: tina.firman@bcinsight.com
Tel: +44 (0)20 7793 2567 Fax: +44 (0)20 7793 2577

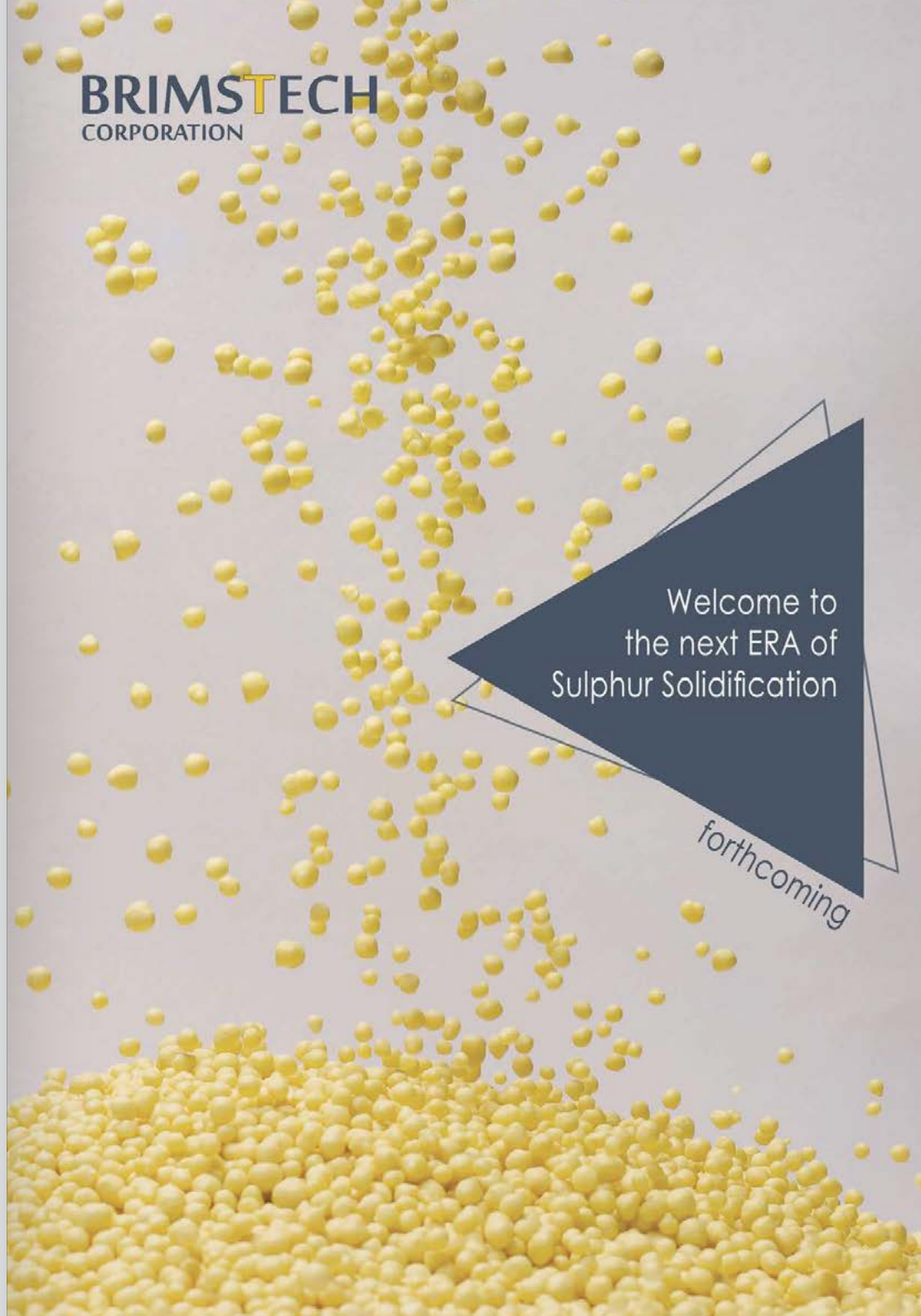

CONTENTS

What's in issue 392

COVER FEATURE 1

Sulphur and plant health

COVER FEATURE 2

Canada's sulphur industry

COVER FEATURE 3

New sulphuric acid catalysts

COVER FEATURE 4

The water side of SRUs

SULPHUR
ISSUE 392
JANUARY-FEBRUARY 2021

BCInsight

Southbank House, Black Prince Road
London SE1 7SJ, England
Tel: +44 (0)20 7793 2567
Fax: +44 (0)20 7793 2577
Web: www.bcinsight.com
www.bcinsightsearch.com

1
2
3
4
5
6
7
8
9
10
11
12
13
14
15
16
17
18
19
20
21
22
23
24
25
26
27
28
29

HUGO PETERSEN
ENGINEERING IS OUR PASSION
Your partner when it comes to sulphuric acid.

Don't forget the next issue
of **Sulphur** March/April 2021

ENVIRONMENT
IMPROVEMENT
ENHANCEMENT
EFFICIENCY
LIFECYCLE



HUGO PETERSEN GmbH
Rheingaustrasse 190-196
65203 Wiesbaden
Tel. +49 (611) 962-7820
Fax +49 (611) 962-9099
contact@hugo-petersen.de

WWW.HUGO-PETERSEN.DE

A subsidiary of
C·A·C
Chemicalanlagenbau Chemnitz GmbH



CONTENTS

What's in issue 392

COVER FEATURE 1

Sulphur and
plant health

COVER FEATURE 2

Canada's sulphur
industry

COVER FEATURE 3

New sulphuric
acid catalysts

COVER FEATURE 4

The water side
of SRUs

SULPHUR
ISSUE 392
JANUARY-FEBRUARY 2021

BCInsight

Southbank House, Black Prince Road
London SE1 7SJ, England
Tel: +44 (0)20 7793 2567
Fax: +44 (0)20 7793 2577
Web: www.bcinsight.com
www.bcinsightsearch.com