

1  
2  
3  
4  
5  
6  
7  
8  
9  
10  
11  
12  
13  
14  
15  
16  
17  
18  
19  
20  
21  
22  
23  
24  
25  
26  
27  
28  
29

# Welcome to our interactive version of **Nitrogen+Syngas** Issue 371

Please use either the buttons on the left or top right of the page to navigate your way around this interactive PDF

**IMPORTANT INFORMATION:**

Copyright – Issued six times per year, or bi-monthly. All rights reserved. No part of this publication may be reproduced, stored in a retrieval system or transmitted in any form or by any means – electronic, mechanical, photocopying, recording or otherwise – without the prior written permission of the Copyright owner.

Number 371

May | June 2021

# nitrogen + syngas

www.nitrogenandsyngas.com

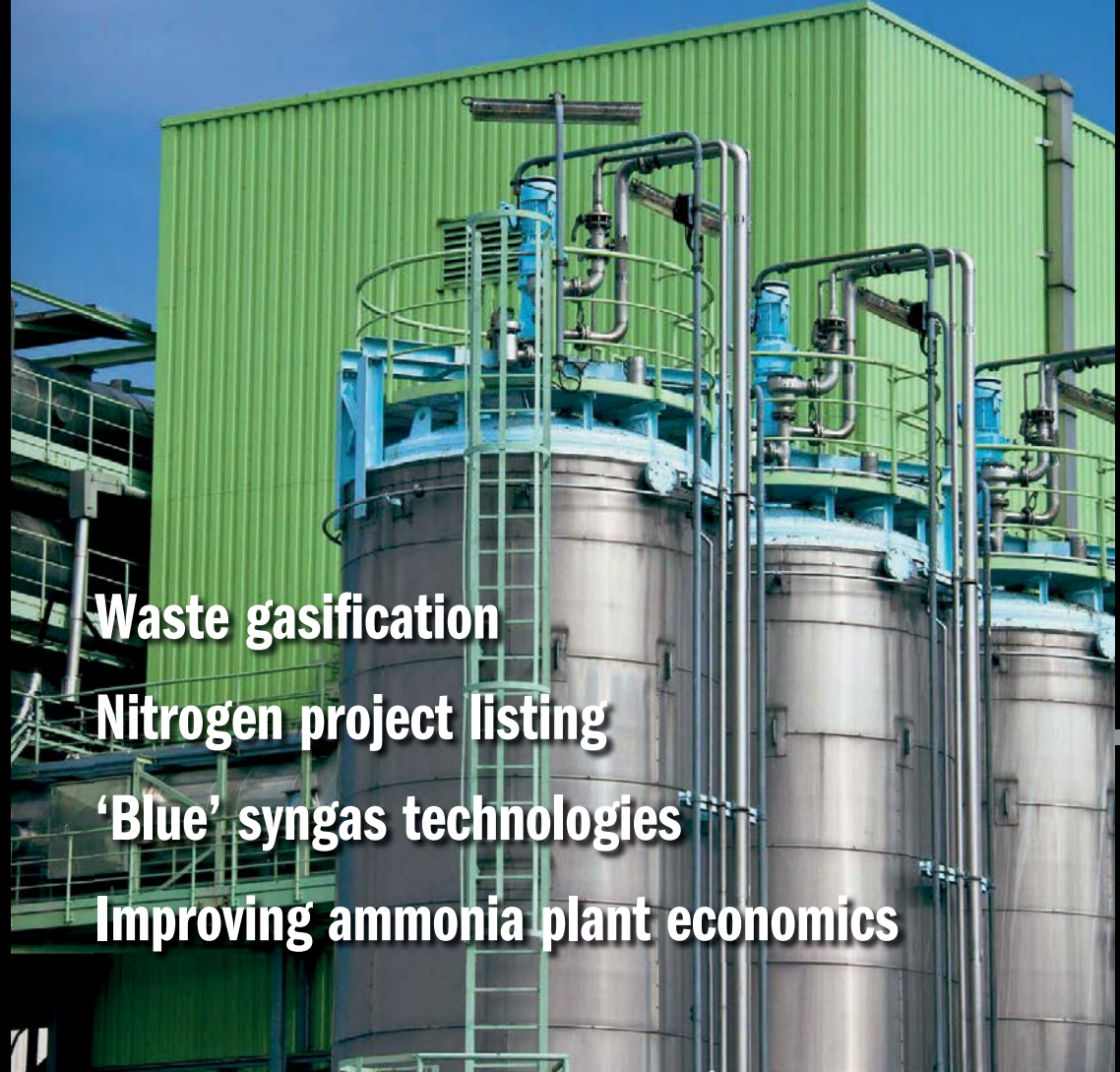

Waste gasification

Nitrogen project listing

'Blue' syngas technologies

Improving ammonia plant economics



CONTENTS

What's in issue 371

COVER FEATURE 1

Waste gasification

COVER FEATURE 2

Nitrogen project listing

COVER FEATURE 3

'Blue' syngas technologies

COVER FEATURE 4

Improving ammonia plant economics

**NITROGEN+SYNGAS**  
**ISSUE 371**  
MAY-JUNE 2021

**BCInsight**

Southbank House, Black Prince Road  
London SE1 7SJ, England  
Tel: +44 (0)20 7793 2567  
Fax: +44 (0)20 7793 2577  
Web: www.bcinsight.com  
www.bcinsightsearch.com

# JM

## Making a difference to the world around us

With years of operating experience and expertise across the syngas, petrochemical, oil and gas markets, Johnson Matthey continues to invest in technologies that improve processes whilst looking after the environment.

Our gas heated reforming technology is a proven energy efficient solution for syngas generation across multiple applications reducing both CO<sub>2</sub> emissions and raw water consumption, whilst maximising the opportunity to use renewable energy.

Contact us to find out how our technology can benefit your business.

**Johnson Matthey**  
Inspiring science, enhancing life

[www.matthey.com](http://www.matthey.com)



Cover: Details of an industrial municipal waste incineration plant. Ulrich Mueller/Shutterstock.com



### 10 Urea markets

New supply may keep prices depressed.

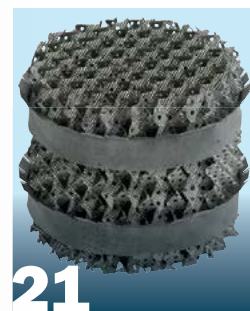

### 21 Gas cleaning technology

Structured packing improves capex and opex.

Read this issue online at:  
[www.nitrogenandsyngas.com](http://www.nitrogenandsyngas.com)

Published by:  
**BCInsight**

# nitrogen + syngas

[www.nitrogenandsyngas.com](http://www.nitrogenandsyngas.com)

NUMBER 371  
MAY | JUNE 2021

## CONTENTS

- 10 The outlook for urea**  
Although the urea market has weathered the pandemic relatively well, a significant amount of new capacity is due to come on-stream in the next year or so, and could keep prices depressed unless more Chinese capacity closes.
- 12 Nitrogen and methanol in the Caribbean**  
Gas availability and pricing continues to affect ammonia and methanol output from Trinidad, while Venezuela struggles with sanctions and political instability.
- 13 Nitrogen project listing 2021**  
*Nitrogen+Syngas's* annual listing of new ammonia, urea, nitric acid and ammonium nitrate plants.
- 15 Waste gasification**  
Gasification technology offers the promise of being able to convert the increasing volumes of municipal waste generated by society into useful chemical products. In spite of a patchy commercial record, interest in the process remains high.
- 17 Blue technologies in the transition to lower carbon footprint**  
The role of blue technologies as part of a roadmap towards the decarbonisation of fuels and chemicals.
- 21 Rectisol™ column design with structured packings**  
By using a Rectisol™ demonstration unit at one of Air Liquide's industrial production sites, Air Liquide Engineering & Construction has gained unique know-how in Rectisol™ column design with structured packings, resulting in significant capex and opex savings.
- 23 The green and safe way to produce ammonium nitrate**  
M. Pieper and P. Kamermann of thyssenkrupp Industrial solutions discuss how to achieve safety in ammonium nitrate plants while maintaining outstanding product quality.
- 26 Improving the process economics of ammonia plant operations**  
The unexpected global Covid-19 pandemic has injected a higher degree of uncertainty for ammonia manufacturers' operating costs and product demand for fertilizer. W. Poe of AVEVA discusses how advanced process control systems can help ammonia producers turn economic uncertainty into a competitive advantage.

## REGULARS

- 3 Editorial**  
A sea change
- 4 Price Trends**
- 4 Market Outlook**
- 5 Nitrogen Industry News**
- 7 Syngas News**
- 9 People/Calendar**
- 10 Plant Manager+**  
Why use a vacuum based leak detection system?

CONTENTS

What's in issue 371

COVER FEATURE 1

Waste gasification

COVER FEATURE 2

Nitrogen project listing

COVER FEATURE 3

'Blue' syngas technologies

COVER FEATURE 4

Improving ammonia plant economics

NITROGEN+SYNGAS  
**ISSUE 371**  
MAY-JUNE 2021

**BCInsight**

Southbank House, Black Prince Road  
London SE1 7SJ, England  
Tel: +44 (0)20 7793 2567  
Fax: +44 (0)20 7793 2577  
Web: [www.bcinsight.com](http://www.bcinsight.com)  
[www.bcinsightsearch.com](http://www.bcinsightsearch.com)

# A sea change

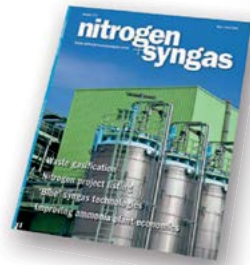

Judging by the pages of the project announcements in our news section, you'd be forgiven for thinking that the ammonia and methanol industries were all running off hydrogen generated from electrolysis, and that we had already entered an era of 'clean' chemical generation which did not require fossil fuels as a feedstock. Of course, while companies can naturally be forgiven for wanting to put the best public face on their green credentials, it does obscure the fact that for the moment 99% of syngas generation comes from natural gas, coal, and some coke or naphtha.

However, when it was published at the end of last year, the International Energy Agency's most recent World Energy Outlook did contain an eye-catching line: "The world's best solar power schemes," it said, "now offer the cheapest... electricity in history, with the technology cheaper than coal and gas in most major countries." As qualified as that statement may be, it is a remarkable development, which has taken less than a decade to move solar and offshore wind from the most to the least expensive ways of generating electricity.

Now, being cost competitive with fossil fuels for electricity production is one thing. Competitive with fossil fuels for making chemicals is quite another, especially given how cheap natural gas is these days; the product of oversupply in the LNG market and cheap shale gas from the United States. But nor is it that far away. Historically, power generators have always been able to outbid chemical producers for natural gas or coal – they can absorb higher prices because it is much easier to build a methanol or urea plant in a cheap gas location and ship it than it is to transport electricity over long distances. This meant that feedstock needed to be proportionately cheaper to make a syngas plant viable than it did a power plant. But the difference was certainly not orders of magnitude – maybe only a question of 50% or so cheaper, depending on the location.

The IEA's statement also bears some closer analysis – a typical gas fired power station has an

on-stream factor of 85% or more, while solar electricity is only going to be working 12-15 hours per day at best. To make up the difference some way of storing the electricity is required. Sufficient battery storage to supply electricity through the night causes solar costs to mount considerably, to possibly double that of an equivalent sized gas-fired generator even at today's prices. But if the electricity is being stored as hydrogen, the cost of building a pressurised, insulated tank is much less than that of a battery.

For all of the hype surrounding green ammonia and methanol, I do get the sense that we are now on the threshold of something quite momentous – a time when renewable energy is not just the worthy thing to do, but actually the most economical way of doing it as well. Once it reaches that level for chemical production, and on present showing there seems no reason to suspect that it won't, at some time in the coming decade, it will be as great a sea change in the industry as the move from coal-based production in Europe to larger scale gas-based production worldwide was for the ammonia and methanol industries in the 1950s and 60s. That too took decades to work its way through – chemical plants are built for lifetimes of 20 years and more, and in some countries like China the change never quite happened, but it will happen. ■

Richard Hands, Editor

## Euromel® Melamine The industry benchmark

24 plants worldwide. 5 million tonnes produced. No pollution. Euromel® is the world's leading melamine technology. Over the last 40 years, Eurotecnic has transformed the melamine market into a global operation by creating a melamine process that turns its Urea feedstock into a product that is profitable and in high demand.

Today, 24 melamine plants around the world have been licensed and implemented on the basis of Euromel®, with a combined annual capacity of more than 860,000 tons. Euromel® has also become the process with the lowest OPEX in the industry with zero-pollution, low energy consumption and no chemicals added for purification. Therefore investing in Euromel® means gaining access to a sustainable technology with a global network of producers.

Contact us at [www.euromel.com](http://www.euromel.com) to find out more.

EUROMEL®

[www.euromel.com](http://www.euromel.com)

EUROTECNICA  
MAKING SUSTAINABILITY PROFITABLE

CONTENTS

What's in issue 371

COVER FEATURE 1

Waste gasification

COVER FEATURE 2

Nitrogen project listing

COVER FEATURE 3

'Blue' syngas technologies

COVER FEATURE 4

Improving ammonia plant economics

NITROGEN+SYNGAS  
ISSUE 371  
MAY-JUNE 2021

BCInsight

Southbank House, Black Prince Road  
London SE1 7SJ, England  
Tel: +44 (0)20 7793 2567  
Fax: +44 (0)20 7793 2577  
Web: [www.bcinsight.com](http://www.bcinsight.com)  
[www.bcinsightsearch.com](http://www.bcinsightsearch.com)

# Price trends

Market insight courtesy of Argus Media

## NITROGEN

Ammonia prices made further gains east of Suez as steady demand from east Asia continues to support pricing. But production is improving across all key supply regions and fundamentals suggest the end of the price rally may be in sight. Saudi Arabian producers Sabic and Ma'aden both brought capacity back online towards late April, which should bring the region back close to normal capacity by May. But it is unlikely much spot will be available until June which is keeping near term sentiment firm.

In the west, there are some signs that the market may have plateaued. Seasonal demand is winding down in the US and Europe in the fertilizer sector, alongside a potential slowdown in industrial demand in northwest Europe. There is a growing list of offers for spot cargoes, from Egypt to Mexico, and expectations are that the Tampa contract price will not post any further gains in May.

A Pivdenny loading cargo will load in April for South Korea, a result of the recent supply crunch in the Middle East. Improved supply is also opening up the possibility of Trinidadian cargoes moving east to South Korea, with prices now providing a potential arbitrage opportunity for June delivered cargoes.

Recent market drivers include Taiwan buying May cargo and Saudi Arabia restarting two plants.

For urea, firmer prices for Chinese product provided some welcome reassurance to the market in mid- to late April, with asking prices moving back up towards \$340/t f.o.b. for May. Reduced production, stronger domestic demand and anticipation of a large Indian tender contributed to the rise.

In the United States, strong demand for spring sowing has lifted barge rates at NOLA to above \$400/t, and supported buying from North Africa. Rising water levels mean that barges are able to transit the upper Mississippi River again.

The other move in mid to late April came in North Africa, where small sales in the low-\$330s/t f.o.b. were followed by larger tonnages sold at \$340-344/t f.o.b. for May. An estimated 300,000 tonnes of urea have been sold from the region in mid-April. This should set a level for Europe and bring buyers elsewhere, who have been hesitating, into the market.

The next support will come from India when a delayed tender is held for May/early-June shipment, likely in the first week of May. Reduced production in India is raising the import requirement and sources expect MMTC to seek more than 1 million tonnes of urea in the tender. India is forecast to have another good year for urea imports in 2021, possibly buying up to 9 million tonnes this year. Recent market drivers include China, India and market fundamentals.

Table 1: Price indications

Cash equivalent	mid-April	mid-Feb	mid-Dec	mid-Oct
<b>Ammonia (\$/t)</b>				
f.o.b. Black Sea	430-470	300-370	204-230	200-210
f.o.b. Caribbean	430-460	290-335	200-230	180-190
f.o.b. Arab Gulf	440-480	290-330	230-260	230-260
c.fr N.W. Europe	490-540	340-420	250-275	225-255
<b>Urea (\$/t)</b>				
f.o.b. bulk Black Sea	300-340	300-380	230-250	230-245
f.o.b. bulk Arab Gulf*	320-355	350-380	260-290	249-270
f.o.b. NOLA barge (metric tonnes)	365-405	329-365	242-250	238
f.o.b. bagged China	320-355	320-365	270-300	265-290
<b>DAP (\$/t)</b>				
f.o.b. bulk US Gulf	572-613	568-600	419-436	367-395
<b>UAN (€/tonne)</b>				
f.o.t. ex-tank Rouen, 30%N	157	157	157	157

Notes: n.a. price not available at time of going to press. n.m. no market. \* high-end granular.

# Market Outlook

Historical price trends \$/tonne

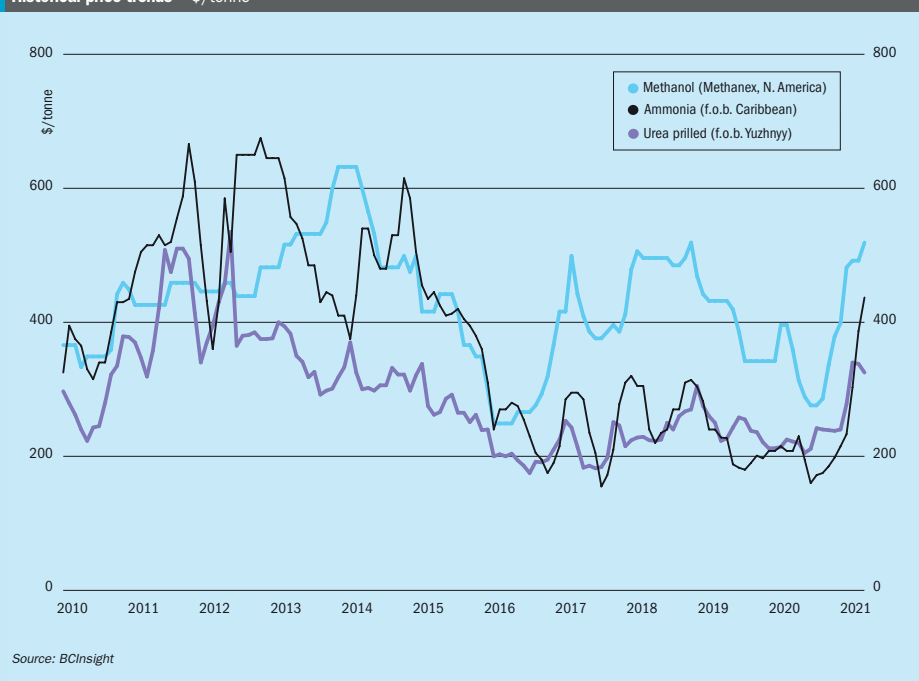

Source: BCInsight

## AMMONIA

- February saw ammonia prices jump due to a series of plant outages, including EBIC in Egypt, and several plants in North America, including two on Trinidad; the 760,000 t/a Nutrien 4 plant and 500,000 t/a Trigen 2 plant, both due to gas shortages, as well as Yara and BASF's 750,000 t/a unit at Freeport, Texas.
- Prices continued to climb through March as availability remained tight, with Tampa prices rising more than \$100/t for a second month running. Supply was also tight through March in the Middle East, and there was little business out of Russia.
- Meanwhile demand continues to be strong globally, offering little relief for buyers in the short term.
- As demand begins to slow into the summer it is likely that prices will peak. However, early June cargoes are still being offered at firmer price levels, and it may not be until mid- to late June when the market starts to see some easing.

## UREA

- With Indian domestic production levels reduced and imports running at high levels, Indian buying continues to set the tone for the market. At the end of April MMTC bought 800,000 t/a, and at time of writing it was believed that it would be back in the market in early May for a further 1.8 million tonnes of urea.
- Much depends upon how much urea is available from China to cover the Indian tenders, and how low a price Chinese producers are willing to bear. It was believed that up to 1.2 million tonnes of Chinese urea could be available.
- In general the urea market is amply supplied, and the market tone has been distinctly bearish over the past few months, with prices on a slow decline. However, MMTC's buying means that prices have found a floor for May and deferred demand may see some increases. Nevertheless, renewed pressure on f.o.b. levels is possible for June-July, despite strong fundamentals.

## METHANOL

- Methanol prices have rebounded significantly from the low point of June 2020 as industrial production has recovered in China, along with methanol-to-olefins demand, although demand for methanol in fuel applications, either as a blendstock or a feedstock for MTBE and other ether production, continues to run at lower levels.
- Strong methanol demand, combined with low global inventory levels and ongoing industry supply challenges continue to drive tight market conditions into the second quarter of 2021, especially in North America.
- On Trinidad, the Natural Gas Corporation has failed to reach agreement with Methanol Holdings Trinidad Ltd (MHTL) on a price for natural gas feedstock, leading the latter to idle two methanol plants on the island; M4 and M5000, until a new gas deal can be arranged. Four of the seven methanol plants at Point Lisas are now idle.

## END OF MONTH SPOT PRICES

### natural gas

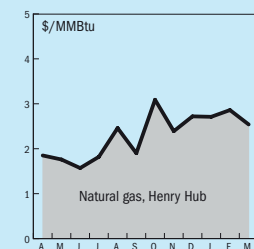

### ammonia

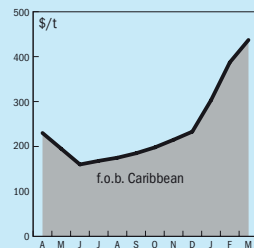

### urea

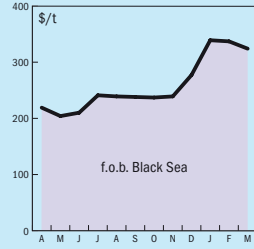

### diammonium phosphate

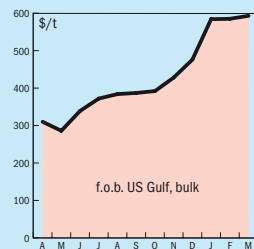

CONTENTS

What's in issue 371

COVER FEATURE 1

Waste gasification

COVER FEATURE 2

Nitrogen project listing

COVER FEATURE 3

'Blue' syngas technologies

COVER FEATURE 4

Improving ammonia plant economics

NITROGEN+SYNGAS  
ISSUE 371  
MAY-JUNE 2021

BCInsight

Southbank House, Black Prince Road  
London SE1 7SJ, England

Tel: +44 (0)20 7793 2567

Fax: +44 (0)20 7793 2577

Web: www.bcinsight.com  
www.bcinsightsearch.com

## GERMANY

### Uhde celebrates its centenary with name change

The Chemical & Process Technologies business unit of thyssenkrupp Industrial Solutions is celebrating a milestone in 2021. It is one hundred years since engineer and entrepreneur Friedrich Uhde founded his own plant engineering company in a barn at his parents-in-law's farm in Dortmund-Bövinghausen on April 6th, 1921. Now, in this centenary year, the origins of the firm are to become visible in its name again: thyssenkrupp is changing the business unit's name to thyssenkrupp Uhde.

After its foundation in 1921, the company soon began to focus on ammonia synthesis, and fertilizer plants remain one of its main areas of business. The enterprise quickly expanded. In 1930 a subsidiary was established for high-pressure technologies which as part of thyssenkrupp now goes by the name Uhde High Pressure Technologies. In 1952 the then Uhde GmbH was acquired by Hoechst AG and in 1996 by Krupp AG, which merged into thyssenkrupp in 1999. In 2014 it was combined with other plant engineering businesses to form thyssenkrupp Industrial Solutions. The core of the former Uhde company is now the

Chemical & Process Technologies business unit, employing 4,500 people, and still based in Dortmund.

The first ammonia plant using the Mont-Cenis-Uhde process went into operation in 1928 and had a production capacity of 100 t/d. Today the company can build plants with capacities of up to 5,000 t/d, and is looking to produce "green ammonia" from hydrogen generated by electrolysis using renewable electricity, via technology from thyssenkrupp Uhde Chlorine Engineers, a joint venture with Industrie De Nora and world market leader in industrial-scale electrolysis.

Sami Pelkonen, CEO of Chemical & Process Technologies/thyssenkrupp Uhde commented: "for 100 years, the name Uhde has stood for innovation, quality, and reliability. It makes me particularly proud that our core technologies – such as ammonia synthesis together with water electrolysis – can now, with green hydrogen and green ammonia, make a key contribution to a sustainable future. So it's really fitting that we'll shortly be known as thyssenkrupp Uhde again."

## Uniper to establish green hydrogen hub

Uniper, one of the largest power producers in Europe, says that it will work together with energy service provider EWE to set up a hydrogen hub at Hüntorf, Lower Saxony. Both companies have signed an agreement to generate hydrogen using renewable energy (wind power) in Hüntorf, store it there and create transport facilities to make it available to industry and the mobility sector.

"With Uniper operating a Compressed Air Energy Storage (CAES) power plant at the Hüntorf site and EWE running a cavern storage facility for natural gas in the immediate vicinity, the project is perfectly set up to succeed in terms of location," said EWE CEO Stefan Dohler. In the future, cavern storage facilities could also be used for hydrogen storage, and existing natural gas pipelines could transport hydrogen. EWE is currently gaining extensive experience by participating in various projects, for example the HyCav-Mobil research project on the use of salt caverns for hydrogen storage. HyWays For Future is already the first market for green hydrogen in the transport sector.

The site's potential for expansion is currently estimated at up to 300 MW, with the individual expansion stages focused on hydrogen sales volume.

Uniper is also planning an import terminal for green ammonia at Wilhelmshaven. The terminal is set to be equipped with an 'ammonia cracker' for producing green hydrogen and will also be connected to

the planned hydrogen network. A 410-MW electrolysis plant is also planned, which – in combination with the import terminal – would be capable of supplying around 295,000 t/a or 10% of the demand expected for the whole of Germany in 2030.

## NORWAY

### Topsoe and Nel to offer end-to-end green ammonia and methanol solutions

Haldor Topsoe and Norwegian firm Nel ASA have signed a memorandum of understanding (MOU) to jointly offer customers complete renewable electricity to ammonia/methanol solutions, combining Nel's alkaline and PEM electrolysis technologies in combination with proven ammonia and methanol technologies from Topsoe. Under the MoU, Topsoe will supply licenses, engineering, proprietary hardware, catalyst and technical services for the its ammonia and eMethanol™ technologies, as well as system integration engineering. Nel intends to supply its alkaline or PEM electrolysis technology and proprietary hardware, and subsystem engineering.

"We are very pleased to take the next step in our excellent relation with Nel. Together, we can offer end-to-end renewable electricity to ammonia and methanol solutions based on the most reliable technologies available today. Driven by our vision to be recognized as the global leader in carbon emission reduction technologies by 2024, we are excited to offer innovative and attrac-

tion low-carbon solutions to our customers. This cooperation speaks directly to our customers' needs as we see massive interest from the market requesting basic engineering, license, and process guarantee in one package," said Amy Hebert, Chief Commercial Officer of Haldor Topsoe.

## DENMARK

### Axens buys Flowvision

Axens says that it has signed a share sale and purchase agreement for the acquisition of Flowvision, based in Odense, an engineering company specialising in emission abatement systems for the reduction of nitrogen oxides in industrial flue gas. Flowvision provides designs and equipment for the entire scope of selective catalytic reduction (SCR) and selective non-catalytic reduction (SNCR) systems, and has a wide range of references across multiple sectors, including heat recovery steam generators (HRSG), biomass boilers, waste to energy, circulating fluidised bed boilers, gas turbines, refining, heaters and steam reformers within petrochemical plants.

"The acquisition of Flowvision's DeNOx business will strengthen our offer in the area of air pollution control and will help us better serve our customers providing them with sustainable solutions, integrated with our processes and equipment, to support their environmental and energy transition challenges," said Jean Sentenac, Chairman and CEO of Axens Group.

## RUSSIA

### Acron completes ammonia revamp

Acron has completed a revamp of its Number 4 ammonia plant at Novgorod, one of the largest in Europe. The plant has successfully passed guarantee test runs to confirm its new updated capacity of 2,500 t/d of ammonia. The plant, which originally cost \$500 million, was commissioned in 2016, and was the first ammonia plant built by Russian engineers without support from foreign contractors. The revamp was conducted in conjunction with Haldor Topsoe, whose revised design included a heat exchange reformer (HTER), as well as making changes to the CO<sub>2</sub> removal section, and other modifications. Despite the obstacles and travel restrictions seen in 2020, the team of Acron engineers and Topsoe specialists, working hundreds of miles apart, completed the revamp of Ammonia-4, and after a successful overhaul in November 2020, the plant reached its new design capacity.

"Haldor Topsoe and Acron have been in a successful partnership for quite a while and the revamp project, that delivered in November 2020, marked another milestone in our cooperation. We believe our companies' partnership will develop further for the benefit of both companies," said Peter Vang Christensen, Managing Director of Haldor Topsoe's Moscow office.

Aleksandr Popov, Chairman of the board of Acron, said: "boosting the Ammonia-4 plant is an important project of Acron Group's investment program. Increasing its capacity will allow to sufficiently increase production of nitrogenogen and compound fertilizers on our Novgorod site."

### Shchekinoazot and Topsoe to work on CO<sub>2</sub> emissions reduction

Haldor Topsoe and Shchekinoazot have signed a Memorandum of Understanding with the objective of reducing the carbon footprint of Shchekinoazot's existing and future plants in Russia's Tula region. Shchekinoazot says that it aims to establish both green and blue methanol, ammonia, and hydrogen production using Topsoe's experience and technologies in reforming, electrolysis, carbon capture and utilisation, and ammonia and methanol synthesis.

Shchekinoazot and Topsoe have worked together for the last 15 years and have successfully implemented five projects together related to ammonia, methanol and hydrogen production, applying technologies and catalysts developed and supplied by Topsoe.

"We believe that with Haldor Topsoe's support we'll be able to lead the green transformation and be one of the frontrunners who will blaze the trail for the Russian chemical industry," said Boris Sokol, President of Shchekinoazot.

## EGYPT

### Stamicarbon to revamp Abu Qir urea plant

Stamicarbon has signed a contract with Abu Qir Fertilizers in Alexandria, for the revamp of one of their urea melt plants (Abu Qir 3). Stamicarbon will deliver the license and the process design package for the revamped plant, which is expected to be operational in 2025. The urea plant was designed in 1996 with a nameplate capacity of 1,750 t/d and a design capacity of 1,925 t/d, using Stamicarbon's CO<sub>2</sub> stripping process.

The scope of the revamp includes a capacity increase 2,370 t/d and a reduction in emissions from the melt plant absorbers to meet local norms. The revamp will use Stamicarbon's *EVOLVE CAPACITY*™ design with medium pressure add-on technology. This allows capacity expansion of a plant without having to invest in high pressure equipment or a high pressure CO<sub>2</sub> compressor, while simultaneously reducing energy consumption via the use of existing margins of the installed equipment. The MP add-on technology allows for large scale capacity revamping, while reducing energy consumption per tonne of final urea product. It consists of a small add-on module connected to the existing plant structure with the option to be switched off to provide additional operational flexibility.

Abu Qir is one of the largest producers of nitrogenous fertilizers in Egypt and the Middle East, producing about 50% of all Egypt's nitrogen fertilizers.

### Contract signed for Tahrir Petrochemical Complex

A \$7.5 billion contract has been signed for the construction of the Tahrir Petrochemical Complex in the Ain Sokhna industrial zone, near the Gulf of Suez. The contract was signed between the Red Sea National Refining and Petrochemicals Company and the General Authority for the Suez Canal Economic Zone, in the presence of prime minister Mostafa Madbouly and Tarek Al Mulla, minister of petroleum and mineral resources.

The project will be built on an area of 3.56 million m<sup>2</sup> and will include a 4 mil-

lion t/a naphtha cracker and downstream facilities with the capacity to produce 1.4 million t/a of ethylene and polyethylene, 900,000 t/a of propylene, 250,000 t/a of butadiene, 350,000 t/a of benzene, and 100,000 t/a of hexene. A single train ammonium nitrate plant with a capacity of 1,060 t/d and a nitric acid plant will also be set up at the complex.

## UNITED STATES

### thyssenkrupp to instal green hydrogen plant at Donaldsonville

thyssenkrupp has entered into an engineering and supply contract with CF Industries to deliver a green hydrogen plant for the production of ammonia at the Donaldsonville complex in Louisiana. Under this contract thyssenkrupp will engineer and deliver a 20 MW hydrogen unit based on their alkaline water electrolysis as well as all necessary utilities. The plant will use renewable energy from the local grid to produce hydrogen which then will be converted to 20,000 t/a of green ammonia in CF Industries' existing ammonia plants. Engineering and procurement activities have been started and first production is scheduled for 2023.

With six ammonia plants and several fertilizer plants, the CF Industries' site in Donaldsonville is the largest ammonia manufacturing complex worldwide. The largest ammonia plant at the site was also designed thyssenkrupp based on the proven Uhde ammonia process. "Following the recent delivery of two world-scale ammonia and fertilizer plants to CF Industries we are honoured to have now been selected by our long-term customer to contribute to the decarbonisation of their operations", said Dennis Lippmann, president Chemical & Process Technologies, thyssenkrupp Industrial Solutions USA.

### Waggaman suffers delayed restart

Incitec Pivot has suffered a delayed restart for its Waggaman ammonia plant in Louisiana. The 800,000 t/a plant began a turnaround in January 2021, the first since the plant was commissioned in 2016. The turnaround was mechanically completed on March 6th, and start-up activity began shortly afterwards, but the plant was taken down again on March 17th due to a dry gas seal failure and vibrations in the turbine on the induced draft fan. Additional investigations into the root causes of both issues have, the company says, now been completed and repairs are currently

## CONTENTS

What's in issue 371

## COVER FEATURE 1

Waste gasification

## COVER FEATURE 2

Nitrogen project listing

## COVER FEATURE 3

'Blue' syngas technologies

## COVER FEATURE 4

Improving ammonia plant economics

NITROGEN+SYNGAS  
**ISSUE 371**  
MAY-JUNE 2021

# BCInsight

Southbank House, Black Prince Road  
London SE1 7SJ, England

Tel: +44 (0)20 7793 2567

Fax: +44 (0)20 7793 2577

Web: www.bcinsight.com  
www.bcinsightsearch.com

underway. Incitec Pivot said that its work plan was expected to result in production recommencing by mid-April. The additional cost of the delay was put at \$28 million on an earnings before interest and tax (EBIT) basis. The total turnaround cost has been finalised at \$62 million, which will be depreciated over a four-year period.

Waggaman's ammonia cooler (heat exchanger) was repaired during the turnaround; however, subsequent metallurgical analysis revealed that poor workmanship of the original fabricated metal would likely prevent the repair from lasting until the next scheduled turnaround. The repairs are expected to allow the plant to restart at full production rates with a replacement of the cooler likely to be required in the next 12-24 months.

**Starfire Energy secures funding for green ammonia and hydrogen plants**

Starfire Energy, a Colorado-based developer of modular chemical plants for the carbon-free production of ammonia and hydrogen, has closed a major funding round. The investment round was led by AP Ventures, a significant investor in breakthrough hydrogen technologies, and included New Energy Technologies, Chevron Technology Ventures, Osaka Gas USA, and Mitsubishi Heavy Industries. The company says that the proceeds will be used to advance the development of commercial-scale applications to decarbonise ammonia production and unlock its potential as a zero-carbon energy carrier.

Starfire's *Rapid Ramp NH3* ammonia synthesis uses only electricity, air, and water as inputs. The company says that the process can accommodate being directly powered by intermittent energy sources such as wind, solar and hydroelectricity. It can scale back to a zero capacity factor and rapidly scale right back to 100% or anywhere in between. Starfire Energy is currently commercializing a 50 t/d modular green ammonia plant. The company has also developed the Prometheus Carbon-free Fire, a system to crack ammonia back into hydrogen, providing an efficient means of green hydrogen storage and transportation.

**CANADA**

**Nutrien to cut emissions 30% by 2030**

Nutrien Ltd, the world's largest fertilizer producer by capacity, has said that it is aiming to cut its greenhouse gas emis-

sions by at least 30% by 2030, in a plan costing the company \$500-700 million.

The plans include cutting emissions from nitrogen production by 1 million tonnes of CO<sub>2</sub> equivalent annually by the end of 2023. Nutrien's target includes Scope 1 and 2 emissions, which reflect direct operations and electricity use, while addressing Scope 3 emissions – those related to on-farm activity – via a program that encourages growers to adopt sustainable practices that generate monetary credits.

The company plans to deploy wind and solar energy at four potash plants by the end of 2025, replacing electricity generated by coal and natural gas. It also plans to expand its sequestration of carbon emissions from nitrogen fertilizer production and to invest in technology to capture nitrous oxide gas from its facilities.

"We're in a really unique spot to address two big societal challenges – food security, and in a way that reduces our environmental footprint," said Mark Thompson, Nutrien's chief corporate development and strategy officer.

**UKRAINE**

**Naftogaz to buy OPZ**

State-owned Ukrainian gas company Naftogaz will buy troubled ammonia and urea producer Odessa Port Plant (OPZ), according to ICIS. The company is also looking to increase its share in renewable electricity generation from less than 1% currently to 25% by 2030, and combine renewable power generation via onshore wind farms with gas production as a feedstock for green ammonia production. The company has launched a solar pilot project in the Kharkiv region, a larger plant in the Zhytomyr region and has conducted pre-feasibility studies on onshore wind in the Odessa region.

**AUSTRALIA**

**Solar-powered ammonia for Western Australia**

Engie and Yara Pilbara Fertilisers have announced plans for a solar-powered hydrogen electrolyser plant in Western Australia, which will be used to produce green ammonia. The project will initially include an 18 MW solar farm and 10 MW electrolyser plant, with the potential to grow to a 100 MW solar operation and 66 MW in the electrolysis system. The joint project has already received A\$995,000 in funding from Australian Renewable Energy Agency (ARENA) for

a feasibility study, and a submission has been lodged with the state's Environmental Protection Authority (EPA). It is estimated that the plant will produce around 640 t/a of green ammonia.

**New urea plant for Western Australia**

Gas producer Strike Energy says that it has begun pre-front end engineering and design (FEED) work on its planned Project Haber urea fertilizer facility, to be built at Geraldton, Western Australia. The facility will use gas from Strike's Greater Irregulla development in the Perth basin as its feedstock. The work follows the completion of a successful feasibility study by Technip Energies, who will also conduct the pre-FEED scope of work to further refine the capital cost estimate for the plant, which is currently \$1.74 billion, according to Strike. Strike says it has also engaged with JBS&G Strategen to start the environmental approvals and planning process, and is engaged in discussions with domestic and international buyers on urea offtake contracts for the anticipated 1.4 million t/a complex.

Technip has also reportedly begun studies to maximise the amount of green hydrogen input into the urea process. Strike says it plans to provide 2% of the hydrogen input via its own 10 MW electrolysis unit that would be powered by geothermal resources in the Perth basin.

**SOUTH KOREA**

**Hanwha to quadruple nitric acid production**

Hanwha Corp. plans to increase its nitric acid production more than fourfold by investing \$170 million. The company's Global Business Division says that it will build a nitric acid plant in the Yeosu Industrial Complex in South Jeolla Province by 2023. The new plant will boost the company's nitric acid production capacity to 520,000 t/a from the current 120,000 t/a. Of the total, 390,000 t/a will be used for production of semiconductor and display cleaning solutions. "We are also laying the groundwork for a transition toward the precision chemical field," a Hanwha official said.

The company has also announced plans to produce 180,000 t/a of dinitrotoluene (DNT), using the remaining 130,000 t/a of nitric acid. DNT is produced through reacting nitric acid with toluene, and is a raw material for toluene diisocyanate (TDI), which is used to produce polyurethane. ■

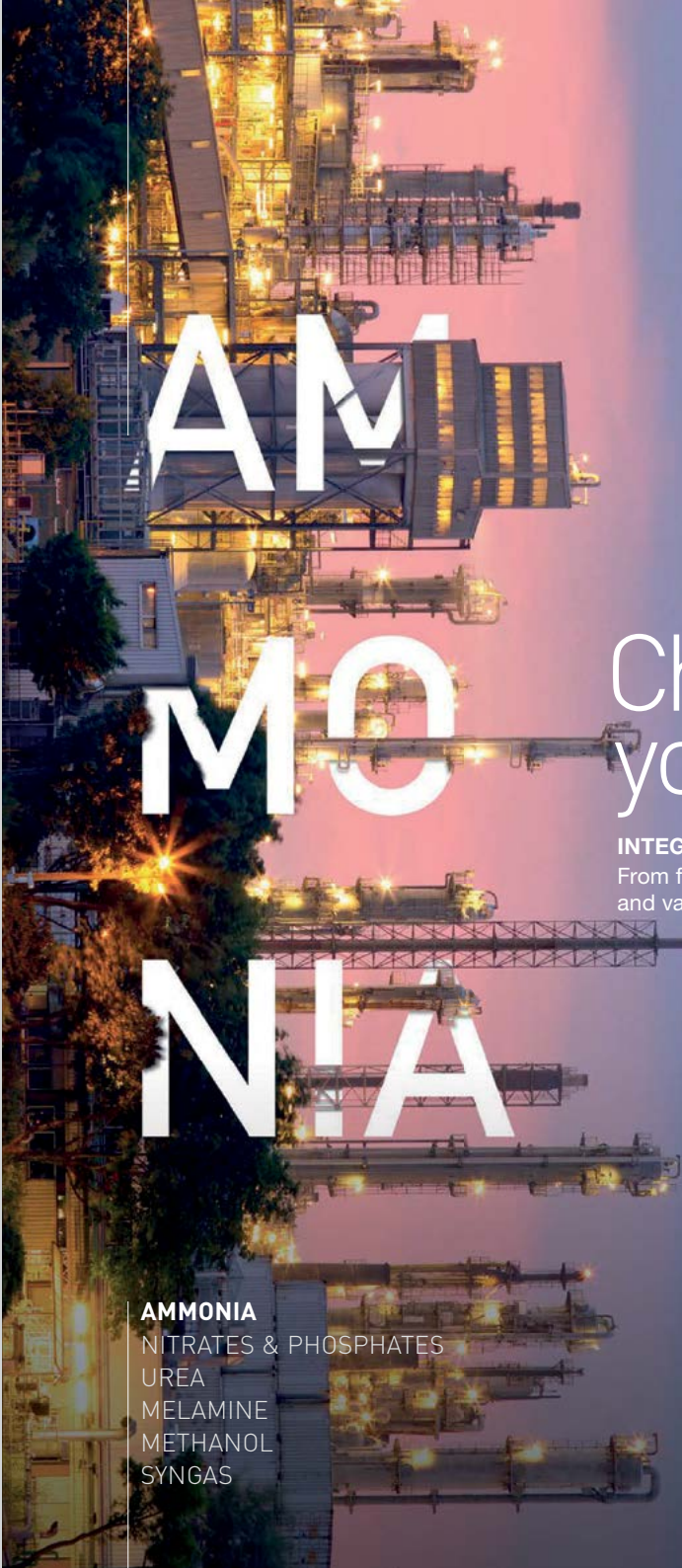

Change your vision

**INTEGRATED PROCESS**  
From feedstocks to any fertilizers and valuable chemicals.

**AMMONIA**  
NITRATES & PHOSPHATES  
UREA  
MELAMINE  
METHANOL  
SYNGAS

**CASALE**  
www.casale.ch  
info@casale.ch



**CONTENTS**

What's in issue 371

**COVER FEATURE 1**

Waste gasification

**COVER FEATURE 2**

Nitrogen project listing

**COVER FEATURE 3**

'Blue' syngas technologies

**COVER FEATURE 4**

Improving ammonia plant economics

**NITROGEN+SYNGAS**  
**ISSUE 371**  
MAY-JUNE 2021

**BCInsight**

Southbank House, Black Prince Road  
London SE1 7SJ, England  
Tel: +44 (0)20 7793 2567  
Fax: +44 (0)20 7793 2577  
Web: www.bcinsight.com  
www.bcinsightsearch.com

UNITED STATES

## Renewable hydrogen to become lower cost than gas-based

A recent report from BloombergNEF (New Energy Foundation) looking ahead to 2050 argues that green hydrogen can be cheaper than natural gas. It finds that 'green' hydrogen from renewables should become cheaper than natural gas (on an energy-equivalent basis) by 2050 in 15 of the 28 markets modelled, assuming scale-up continues. These countries accounted for one-third of global GDP in 2019. In all of the markets BNEF modelled, 'green' hydrogen should also become cheaper than both 'blue' hydrogen (from fossil fuels with carbon capture and storage – CCS) and even 'grey' hydrogen from fossil fuels without CCS. The cost of producing 'green' hydrogen from renewable electricity should fall by up to 85% from today to 2050, the report predicts, leading to costs below \$1/kg (\$7.4/MMBtu) by 2050 in most markets. These costs are 13% lower than BNEF's previous 2030 forecast and 17% lower than their previous 2050 forecast. Falling costs of solar photovoltaic (PV) electricity are the key driver behind the reduction; BNEF now believes that PV electricity will be 40% cheaper in 2050 than they had thought just two years ago, driven by more automatic manufacturing, less silicon and silver consumption, higher photovoltaic efficiency of solar cells, and greater yields using bifacial panels.

Martin Tengler, lead hydrogen analyst at BloombergNEF commented: "Such low renewable hydrogen costs could completely rewrite the energy map. It shows that in future, at least 33% of the world economy could be powered by clean energy for not a cent more than it pays for fossil fuels. But the technology will require continued government support to get there - we are at the high part of the cost curve now, and policy-supported investment is needed to get to the low part."

"By 2030, it will make little economic sense to build 'blue' hydrogen production facilities in most countries, unless space constraints are an issue for renewables. Companies currently banking on producing hydrogen from fossil fuels with CCS will have at most ten years before they feel the pinch. Eventually those assets will be undercut, like what is happening with coal in the power sector today."

"On one hand the reduction in the forecast was surprising, on the other hand not. This is how it goes with clean energy. Every year it gets cheaper, faster than anyone expects. The key driver is the falling cost of solar PV electricity. We now think solar PV power will be 40% cheaper by 2050 than what we had thought just two years ago."

## Nacero selects Topsoe's TIGAS™ technology

Nacero has licensed Topsoe TIGAS technology for its multi-billion dollar natural-gas-to-gasoline facility in Penwell, Texas to produce 100,000 bbl/d of gasoline component ready for blending to US commercial grades. The plant will produce gasoline from low-cost natural gas, captured bio-methane from farms and landfills, and mitigated flared gas from the Permian basin. Topsoe is providing engineering and design services currently and will supply catalyst and propri-

etary hardware to the facility. The Penwell facility will be the first gasoline manufacturer in the world to incorporate carbon capture and sequestration. The captured CO<sub>2</sub> will be used for enhanced oil recovery.

"By making our gasoline from natural gas, renewable natural gas, and captured flare gas rather than crude oil, Nacero will offer America's 225 million drivers an affordable, everyday climate solution," said Jay McKenna, Nacero President and CEO. "The TIGAS technology enables us to cut both the production cost and the lifecycle carbon footprint of everyday fuel by 50%. As

a result, we will be able to profitably sell our environmentally superior fuel at competitive prices. We will use existing vehicles, markets, and infrastructure to quickly, predictably, and cost effectively bring Nacero Blue and Green gasoline to US markets and help mitigate climate change."

TIGAS incorporates Topsoe's SynCOR Methanol technology. The Penwell plant will use six SynCOR trains to produce more than 30,000 t/d of methanol, which will then be processed to gasoline. The only byproduct will be water, which will be recovered and used to supply 80% of the

Computer rendering of the planned Nacero Penwell facility.



plant's make-up water. The Penwell facility will also produce 'blue' hydrogen.

TRINIDAD & TOBAGO

## Two more methanol plants shut down

Methanol Holdings Trinidad Ltd (MHTL) has closed down two of its methanol plants at Point Lisas after failing to secure a gas supply agreement with the National Gas Company of Trinidad & Tobago. The closure of the M4 and M5000 plants means that four of the seven methanol plants at the sprawling Point Lisas site are now idled, as well as several ammonia units at the site. Trinidad's gas production continues to decline and is now at its lowest level in 16 years, while the high price of natural gas that NGC is trying to achieve renders the operation of many plants uneconomic.

MHTL, operated by the Swiss-based Proman Group, will continue to operate its M2 and M3 methanol units, which use gas supplied by DeNovo.

WORLD

## World added record new renewable energy capacity in 2020

Despite the covid-19 pandemic, more than 260 GW of renewable energy capacity was added globally in 2020, beating the previous record by almost 50%, according to data released by the International Renewable Energy Agency (IRENA). IRENA's annual Renewable Capacity Statistics 2021 shows that renewable energy's share of all new generating capacity rose considerably for the second year in a row. More than 80% of all new electricity capacity added last year was renewable, with solar and wind accounting for 91% of new renewables. Renewables' rising share of the total is partly attributable to net decommissioning of fossil fuel power generation in Europe, North America and for the first time across Eurasia (Armenia, Azerbaijan, Georgia, Russian Federation and Turkey). Total fossil fuel additions fell to 60 GW in 2020 from 64 GW the previous year, highlighting a continued downward trend of fossil fuel expansion.

The 10.3% rise in installed capacity represents expansion that beats long-term trends of more modest growth year on year. At the end of 2020, global renewable generation capacity amounted to 2,799 GW with hydropower still accounting for the largest share (1,211 GW) although solar and wind are catching up fast. The two variable sources of renewables dominated

capacity expansion in 2020 with 127 GW and 111 GW of new installations for solar and wind respectively.

China and the United States were the two outstanding growth markets from 2020. China, already the world's largest market for renewables, added 136 GW last year, with the bulk coming from 72 GW of wind and 49 GW of solar. The United States installed 29 GW of renewables last year, nearly 80% more than in 2019, including 15 GW of solar and around 14 GW of wind. Africa continued to expand steadily with an increase of 2.6 GW, slightly more than in 2019, while Oceania remained the fastest growing region (+18.4%), although its share of global capacity is small and almost all expansion occurred in Australia.

DENMARK

## Maersk says it will meet carbon neutral methanol vessel deadline

Maersk says that is optimistic it will fulfil its commitment to operate a carbon neutral methanol-powered ship by 2023. The company's head of decarbonisation Morten Bo Christiansen says that the company's commitment to a having carbon neutral ship running on green methanol in 2023 is 'extremely tough', but the company is in talks to secure the necessary supply of the fuel, and Maersk has a 'relatively solid path' towards its 2023 plan for a carbon-neutral methanol-powered ship.

The company committed in February to having a dual-fuel feeder ship running on carbon-neutral methanol by 2023. At the time of its announcement it had not secured a green methanol supply partnership and had not decided where the vessel would operate. It also pledged that all of its newbuild vessels from 2023 onwards would be capable of running on carbon-neutral means. Maersk had previously committed to having net zero CO<sub>2</sub> emissions from its operations by 2050.

## Blue World and Alfa Laval working on methanol fuel cells for shipping

Methanol fuel cell developer Blue World Technologies is supplying an innovative fuel cell system based on high-temperature proton exchange membrane (HTPEM) technology for testing at the Alfa Laval Test & Training Centre in Aalborg. The test installation, which will use methanol as fuel, will explore the technology's potential as a source of marine auxiliary power. The project, funded by the Danish EUDP (Energy

Technology Development and Demonstration Program), is a joint effort between fuel cell maker Blue World Technologies, Alfa Laval and vessel owners DFDS, Maersk Drilling and Hafnia.

The aim of the project is to establish a highly efficient and cost-effective HTPEM fuel cell solution, giving marine vessels a realistic alternative to combustion-based auxiliary power within the near future. The fuel cell test setup will have a power of 200 kW, but the fully developed and modular design should be possible to scale up incrementally to a level of 5 MW.

GERMANY

## 'Green' hydrogen from waste to energy plant



Hydrogen tanks at a Linde facility.

Linde Engineering has been selected for the design and construction of an integrated hydrogen fuelling station and electrolysis plant for AGR in Herten. The project comprises hydrogen production using proton exchange membrane (PEM) electrolyzers, compressors, storage tanks and high-performance fuelling stations. It will receive funding of up to €6.2 million from the German Federal Ministry of Transport and Digital Infrastructure via the National Innovation Program Hydrogen and Fuel Cell Technology (NIP). The contract also includes provisions for Linde to provide maintenance and service. The electrolyzers will have a capacity of around 440 t/a of hydrogen.

Electricity will come from AGR's waste-to-energy thermal power plant, where municipal and commercial waste with a biogenic content of around 50% serves as the primary fuel source. The planned fuelling station will be able to fill vehicles at 350 bar and 700 bar and therefore will be suitable for both cars and trucks. The hydrogen produced in Herten will primarily be used to supply both public and private transportation vehicles, but the focus will

CONTENTS

What's in issue 371

COVER FEATURE 1

Waste gasification

COVER FEATURE 2

Nitrogen project listing

COVER FEATURE 3

'Blue' syngas technologies

COVER FEATURE 4

Improving ammonia plant economics

NITROGEN+SYNGAS  
ISSUE 371  
MAY-JUNE 2021

BCInsight

Southbank House, Black Prince Road  
London SE1 7SJ, England  
Tel: +44 (0)20 7793 2567  
Fax: +44 (0)20 7793 2577  
Web: www.bcinsight.com  
www.bcinsightsearch.com

be on waste trucks serving the surrounding communities, AGR's own fleet, and the sale of hydrogen to commercial and industrial enterprises.

"The collaboration is a good example of how Linde can support companies and municipalities with an integrated hydrogen offering," says Michael Schäffer, Head of Hydrogen and Syngas Plants at Linde Engineering. "This ambitious project includes superior solutions, such as electrolysis and refuelling technologies, which fit well with AGR's ambitions for an environmentally friendly circular economy."

#### FRANCE

### Hydrogen cargo vessel to begin commercial operation

The European innovation project Flagships will deploy the world's first commercial cargo transport vessel operating on hydrogen on the river Seine in Paris later this year. The hydrogen cargo transport vessel will be owned by French inland shipowner Compagnie Fluviale de Transport (CFT), a subsidiary of the Sogestran Group. The company is currently developing a new business for urban distribution with transport vessels in the Paris area. The new vessel will be tasked with moving goods on pallets and in containers along the river Seine.

The Flagships project was awarded euro 5 million of funding in 2018 from the EU's Research and Innovation programme Horizon 2020, under the Fuel Cells and Hydrogen Joint Undertaking (FCH JU), to deploy two hydrogen vessels in France and Norway. The vessel will operate on compressed hydrogen produced from electrolysis. The power generation system will be supplied by ABB Marine & Ports, with fuel cells from Ballard. LMG Marin is responsible for detail design drawings, with hydrogen provided by suppliers in the Paris region.

#### NETHERLANDS

### Alliance to bring green hydrogen to European market

Proton Ventures BV, trading company Trammo, and VARO, an European mid- and downstream energy company, have signed a memorandum of understanding to form the 'Transhydrogen Alliance', a joint initiative on the production and import of green hydrogen and ammonia into Europe via Rotterdam, as well as export from selected locations worldwide. The Port of Rotterdam Authority supports this consortium, especially in its effort

to set up an import terminal in Rotterdam for these new supply chains.

The consortium will begin with an initial project for the production of green hydrogen produced from solar and wind rich areas and the import of this hydrogen in the form of green ammonia into Europe. The initial project is expected to be completed by 2024. Following success of the initial project, the Transhydrogen Alliance will target the import up to 500,000 t/a of green hydrogen equivalent via up to 2.5 million t/a of green ammonia per year via the Port of Rotterdam.

#### INDIA

### Tecnimont to develop green hydrogen projects in India

Maire Tecnimont, via its subsidiaries NextChem, Stamicarbon and MET Development, has signed a memorandum of understanding with Adani Enterprises Ltd (AEL) to explore the development of industrial projects using NextChem and Stamicarbon's technologies and MET DEV's project development capabilities to industrialise green chemistry and circular economy sectors in India. The projects will be focused on producing chemicals, ammonia and hydrogen from renewable feedstocks.

AEL is part of the Adani Group, India's largest player in the infrastructure and energy sectors, including 14 GW (gigawatt) of renewable assets under operation, construction and contracts. AEL is strongly committed to enabling the renewable transition via its 3.2 GW of existing and planned annual solar panel manufacturing capability and incubation of innovative environmentally friendly technologies. Under the agreement, AEL and Tecnimont's subsidiaries will jointly explore integrated opportunities for the monetisation of renewable feedstocks via NextChem's and Stamicarbon's technologies for chemicals, ammonia and green hydrogen applied to the chemicals value chain.

#### CANADA

### Carbon Engineering to offer carbon dioxide removal service

Carbon Engineering has launched a new carbon dioxide removal service that allows customers to purchase the removal of carbon dioxide from the atmosphere using CE's large-scale 'direct air capture' (DAC) technology. Shopify, a leading global e-commerce company based in Ottawa,

Canada, has signed on as the first customer for the service, reserving 10,000 tonnes of permanent carbon removal capacity via a large-scale DAC project.

The carbon dioxide removal will be achieved through CE's plant development partner, 1PointFive – a US development company currently engineering CE's first industrial-scale facility, which is expected to be operational in 2024. DAC removes carbon dioxide directly from the atmosphere, enabling it to be permanently, securely and measurably put back underground. The new service allows customers to purchase carbon removal units in quantities as small as 100 units. Each unit represents one metric tonne of carbon dioxide captured and permanently removed from the atmosphere, offsetting emissions from the past, present or future. Customers pre-pay a deposit for their carbon removal units, with the remainder due only once the carbon dioxide has been physically removed and independently verified. Customers will receive discounts for purchasing higher volumes.

#### SWEDEN

### Siemens to invest in Liquid Wind consortium

After several years of collaboration, Siemens has agreed to take an equity stake in power-to-fuel developer Liquid Wind AB to produce renewable methanol and significantly reduce carbon emissions from shipping. Siemens Energy will contribute technology and expertise to the development of eMethanol facilities.

Liquid Wind's facilities will integrate a 70 MW PEM electrolyser built by Siemens Energy, which will use renewable electricity to split water into green hydrogen and oxygen. In addition to the electrolyser, Siemens Energy will also supply the entire power distribution, electrification, instrumentation, motors, drives and plant-wide automation for the facility. Digital tools will support the operation, optimisation and replication of the standardised facilities.

"eMethanol will be one of the drivers in the future of transportation and Siemens Energy wants to be an active part of this," said Engelbert Schrapp, Principle Corporate Account Manager of Siemens Energy.

"After close collaboration for five years we are pleased to officially welcome Siemens Energy to the Liquid Wind project," said Claes Fredriksson, CEO and founder of Liquid Wind. "They bring a broad range of valuable expertise, solutions and contacts.

Their systems and collaborative spirit will play a crucial role in enabling the efficient replication of eMethanol facilities to meet growing demand for carbon neutral fuel."

UK-based carbon capture company Carbon Clean has also recently entered into an agreement with Liquid Wind to develop, standardise, and supply carbon capture technology and expertise to support the production of carbon neutral marine fuels. Carbon Clean's technology will capture biogenic carbon dioxide emissions from a local industrial site. Within the Liquid Wind facility, the CO<sub>2</sub> will then be combined with renewable hydrogen to form methanol.

The initial project will be built in Örnsköldsvik, on the northeastern coast of Sweden. Once operational from early 2024, the fuel facility will turn 70,000 t/a of CO<sub>2</sub> into 50,000 t/a of carbon neutral methanol. By replacing fossil fuels, the methanol will prevent up to 100,000 tonnes of carbon dioxide emissions per year.

Liquid Wind ultimately plans to develop up to 500 operational sites globally by 2050. The project has support from a consortium including Haldor Topsoe and Alfa Laval, as well as Carbon Clean and Siemens Energy.

#### SPAIN

### Waste-to-methanol plant in Tarragona

Repsol says that it will join the Ecoplanta project, together with Enerkem and Grupo Agbar to build a waste-to-methanol plant in Tarragona, Spain. Under the joint venture Ecoplanta Molecular Recycling Solutions, the plant will process around 400,000 t/a of non-recyclable municipal solid waste from the city's surrounding regions and produce 220,000 t/a of methanol. This methanol will be used as raw material to produce circular materials or advanced biofuels, contributing to avoid 200,000 t/a of CO<sub>2</sub> and reducing the waste that ends up in the landfill. This alliance is a further step towards the multi-energy company's ambition to become a net-zero emissions company by 2050.

The plant, the first of its kind in the Iberian Peninsula, will be co-managed by Repsol and Agbar, whilst Enerkem will be the key technological partner. The plant is projected to be in operation in 2025 after taking the project's final investment decision by the first quarter of 2022. The project already obtained the Integrated Environmental Authorization and the approval of the Environmental Impact Statement from the local authorities.

The plant will use gasification technology to transform municipal solid waste into high value-added products such as methanol. Enerkem is the owner of this patented technology, the first to be tested on an industrial scale, after a rigorous scale-up from pilot to demonstration to commercial scale that took place over a decade, in its commercial demonstration plant in operation in Edmonton, Alberta, and a new facility under construction in Varennes, Québec.

Jose Luis Bernal, Repsol's Executive Director for Chemicals, said: "We are very pleased to join forces with relevant waste management and innovative technology partners, showing our commitment to circular economy and reinforcing our commitment to recycle 20% of our polyolefins production by 2030."

### Hydrogen electrolysis hubs

Siemens Energy and Messer Group have entered into a cooperation agreement to work on green hydrogen projects in the 5-50 Megawatt (MW) range for industrial and mobility applications. Within the framework of this agreement, Messer Ibérica has already submitted three clean hydrogen projects in the chemical complex of Tarragona to the Spanish government. These projects will have a total electrolyser capacity of 70 MW. The intention of the partners is to achieve the most economic operation possible, by maximising cost efficiency and the utilisation of all co-products in an integrated hub concept. In the Tarragona chemical park Messer Ibérica operates a pipeline network for oxygen where this electrolysis co-product will be used.

Decarbonisation is a top priority of governments worldwide in order to combat climate change. Spain's "Hydrogen Roadmap" places the country at the forefront of this movement, building on its advantageous geography for the generation of renewable energy. The chemical industry in Tarragona, one of Europe's largest chemical parks, has identified renewable hydrogen based on electrolysis as an essential solution to replace fossil fuels in its processes.

Stefan Messer, owner and CEO of Messer Group GmbH, said: "We are focused on developing technologies that make our customers' production processes safer, more efficient and eco-friendly, including clean hydrogen applications in industry and in mobility. In Europe, Asia and the Americas, we already operate gases production facilities expertly on-site, optimizing the use of all co-products, allowing customers to concentrate on their

core businesses whilst enjoying environmental and commercial benefits. Together with Siemens Energy we will extend these advantages to industrial customers switching to green hydrogen produced by electrolysis."

#### BRAZIL

### Linde to support \$5.4 billion hydrogen hub

Linde subsidiary White Martins has signed a preliminary agreement with the Pecém Industrial and Port Complex (CIPP) to support the development of a green hydrogen hub in Brazil. The Port complex will be built by Australia's Enegix Energy following an investment of \$5.4 billion to develop the hub with support from White Martins. White Martins hopes to expand on its current industrial gases plant, situated in the Port, by introducing new facilities that support hydrogen production and distribution, ammonia production and the use of hydrogen in transport. The Port complex already contains multiple heavy industrial facilities including steel, fertilisers, cement and mining with the new hydrogen project looking to develop new sustainable variants in each of these products.

#### CHINA

### Air Products acquires full ownership of gasification joint venture

Air Products says it has completed the acquisition of the remaining 50% equity stake in its gasification technology joint venture (JV) with China Shenhua Coal to Liquid and Chemical Co. Ltd., a subsidiary of China Energy Group, for an undisclosed sum. Air Products acquired its initial 50% stake in the JV as part of its acquisition of General Electric Company's gasification business from GE Power in 2019. The company says that the transaction further strengthens its broader gasification technology portfolio and integrates technical and engineering resources in China.

"Our latest investment is another step to support our gasification growth strategy that addresses the world's energy and environmental challenges. We continue to execute several megaprojects in China and around the world. The acquisition further strengthens our position to leverage our complete gasification technology portfolio to serve our customers," said Seifi Ghamsi, chairman, president and chief executive officer at Air Products. ■

#### CONTENTS

What's in issue 371

#### COVER FEATURE 1

Waste gasification

#### COVER FEATURE 2

Nitrogen project listing

#### COVER FEATURE 3

'Blue' syngas technologies

#### COVER FEATURE 4

Improving ammonia plant economics

NITROGEN+SYNGAS  
ISSUE 371  
MAY-JUNE 2021

BCInsight

Southbank House, Black Prince Road  
London SE1 7SJ, England

Tel: +44 (0)20 7793 2567

Fax: +44 (0)20 7793 2577

Web: www.bcinsight.com  
www.bcinsightsearch.com



## People

**Hans Vrijenhoef** has stepped down as Chief Executive Officer of Proton Ventures with immediate effect. He will continue to serve as non-executive chairman of the management board for at least another three years to support the growth of the existing business of green ammonia production technologies. **Paul Baan** succeeded Hans Vrijenhoef as of April 1st, 2021. Baan has served in leadership positions at Ørsted and EON. He is an engineer by background who has a strong understanding of Power to X technology and business cases.

Vrijenhoef said: "I am very happy that Paul is joining Proton Ventures as CEO and that we can work together on the energy transition. I am highly confident that under his leadership, Proton Ventures will prosper long into the future. His appointment demonstrates the strength of Proton Ventures' innovative mindset and its thought leadership position in green ammonia production."

"It has been an honour and a pleasure for me to lead Proton Ventures during the last 20 years... I look forward to continuing to engage with all stakeholders in the coming years to further drive innovation and execute engineering projects related to green ammonia production and storage. I also look forward to continuing to dedicate my time and my experience to the recently announced TransHydrogen Alliance which we created together with VARO Energy, Trammo and Port of Rotterdam to announce our joint ambition to import up to 2 million tons per year of green ammonia from solar and wind rich areas to Rotterdam."

**Chuck Magro** is to step down as CEO of Nutrien Ltd, the world's largest fertilizer maker, in order to pursue new opportunities. The company has named **Mayo Schmidt** its new chief executive officer. Magro will be "available to" the company until May 16th to facilitate a smooth transition, according to a Nutrien statement.

"I look forward to leading the continued execution of Nutrien's strategy and driving industry-leading performance across all our lines of business," Schmidt said in a statement. "Over the coming weeks, I will be connecting with our employees, valued customers and shareholders to continue building our positive momentum and our focus on advancing sustainable solutions to feed a growing planet."

Schmidt was named chair of Nutrien's board of directors in May 2019 and will remain on the board. He previously served as president and CEO of Viterro and Hydro One Ltd. Russ Girling, the former president and CEO of TC Energy, was named the new chair of Nutrien's board of directors.

Nutrien was created in 2018 after the merger of Agrium and PotashCorp. Magro, who was the CEO of Agrium at the time of the merger, was named Nutrien's CEO.

"I am very proud of the strong foundation we have built at Nutrien over the last several years," Magro said, who also resigned from Nutrien's board of directors. "I am grateful for the dedication of our employees, and the important partnerships we have forged with our customers and stakeholders. I have enjoyed every moment

of my time at Nutrien, and I wish the company and its people continued success."

Fertilizer Canada has appointed **Karen Proud** as President and Chief Executive Officer. Proud assumes leadership from Garth Whyte, who has served as President since 2015. Whyte announced his retirement in the summer of 2020. Prior to joining Fertilizer Canada, Proud was the COO of Food Health and Consumer Products of Canada.

"Fertilizer Canada has a well-earned reputation in both programming and advocacy initiatives," said Proud. "Having worked for a number of manufacturing and retail sectors I am excited to take on this new role aimed at advancing the safe, secure, and sustainable production and use of fertilizer in Canada and around the world."

"Karen's experience in association management and regulatory negotiation will ensure a continued focus on our industry's priorities, including achieving federal recognition for 4R Nutrient Stewardship as the national standard for nutrient management and the industry's codes of practice as the standard in product safety, as outlined in our Strategic Plan 2025," said Brian Markand, Chair, Board of Directors, Fertilizer Canada. "As a proven leader and relationship-builder, in combination with her extensive background and knowledge of government decision making, Karen will further develop and build upon Fertilizer Canada's foundation of achieving fair, competitive and science-based policies."

# Make your plant fit for the future



100 years ago, Friedrich Uhde saw a huge demand for ammonia to ensure food supplies. That was the birth of Uhde in 1921. Today, thyssenkrupp Uhde is a choice provider of one-stop solutions for upgrading your grey ammonia plant to blue and/or green ammonia. We do this by taking our vast experience in the uhde® ammonia process and adapting it with our uhde® alkaline water electrolysis for green ammonia or with our uhde® CO<sub>2</sub> sequestration unit for blue solutions. But the story does not end here because thyssenkrupp uhde also offers you best-in-class solutions in fertilizer and methanol technologies to shape you up for the future. We have been your valued partner for a century and we are there for the future, too.

[www.thyssenkrupp-industrial-solutions.com](http://www.thyssenkrupp-industrial-solutions.com)



engineering.tomorrow.together.



CONTENTS

What's in issue 371

COVER FEATURE 1

Waste gasification

COVER FEATURE 2

Nitrogen project listing

COVER FEATURE 3

'Blue' syngas technologies

COVER FEATURE 4

Improving ammonia plant economics

NITROGEN+SYNGAS  
ISSUE 371  
MAY-JUNE 2021

BCInsight

Southbank House, Black Prince Road  
London SE1 7SJ, England  
Tel: +44 (0)20 7793 2567  
Fax: +44 (0)20 7793 2577  
Web: [www.bcinsight.com](http://www.bcinsight.com)  
[www.bcinsightsearch.com](http://www.bcinsightsearch.com)

## Calendar 2021

### MAY

26-27

Syngas Nitrogen Russia and CIS,  
MOSCOW, Russia  
Contact: Milana Stavnya,  
Programme producer, Vostock Capital  
Tel: +7 499 505 1 505  
Email: [MStavnaya@vostockcapital.com](mailto:MStavnaya@vostockcapital.com)

### JUNE

DATE T.B.C.

Argus East Europe Fertilizer,  
Location T.B.C.  
Contact: Argus Media  
Tel: +44 (0) 20 7780 4340  
Email: [conferences@argusmedia.com](mailto:conferences@argusmedia.com)

**!** The following events may be subject to postponement or cancellation due to the global coronavirus pandemic. Please check the status of individual events with organisers.

3-4

NH3 Event, ROTTERDAM, Netherlands  
Contact: NH3 Event Europe  
Tel: +31 10 4267275  
Email: [info@nh3event.com](mailto:info@nh3event.com)

22-24

China International Fertilizer Show,  
SHANGHAI, China  
Contact: CCPIT Sub-Council of Chemical Industry, Tel: +86 10 8425 5960  
Email: [zhengyingying@ccpitchem.org.cn](mailto:zhengyingying@ccpitchem.org.cn)  
Web: [en.fshow.org](http://en.fshow.org)

28-30

IFA Annual Conference, LISBON, Portugal  
Contact: IFA Conference Service,  
49 Avenue d'Iena, Paris, F75116, France.  
Tel: +33 1 53 93 05 00

Email: [ifa@fertilizer.org](mailto:ifa@fertilizer.org)

### AUGUST

29-SEPTEMBER 2

65th AIChE Annual Safety in Ammonia  
Plants and Related Facilities Symposium,  
SAN DIEGO, California, USA  
Contact: Ilia Kileen, AIChE  
Tel: +1 800 242 4363  
Web: [www.aiche.org/ammonia](http://www.aiche.org/ammonia)

### SEPTEMBER

27-29

IFA Annual Conference, LISBON, Portugal  
Contact: IFA Conference Service,  
49 Avenue d'Iena, Paris, F75116, France.  
Tel: +33 1 53 93 05 00  
Email: [ifa@fertilizer.org](mailto:ifa@fertilizer.org)

# Plant Manager+

## Why use a vacuum based leak detection system?

In the March-April issue of *Nitrogen+Syngas*, *Plant Manager+* reported on how to prevent safety risks with a proper leak detection system. In this issue we continue the discussion by further exploring the benefits of vacuum based leak detection systems,

which provide several benefits including: less clogging, no build up of pressure, only one ammonia analyser needed for the high pressure equipment, works when there is only one leak detection hole, as well as when there are clogged or no grooves.

High pressure urea equipment consists of a carbon steel pressure bearing wall, which is protected against corrosion by a protective layer – typically an overlay welding or a loose liner. Any leak in a loose liner will lead to a dangerous situation exposing the carbon steel wall to extremely corrosive ammonium carbamate.

Different types of active leak detection systems are available: in a pressurised system, an inert carrier gas stream flows through the leak detection circuits and in a vacuum based system, vacuum pressure is pulled behind the liner.

### How to avoid clogging

It is a real challenge to avoid clogging as urea easily crystallises at any temperature even above its melting point due to its polymerisation behaviour forming biuret, triuret etc. with high melting points. This is the main reason for upgrading a passive leak detection system.

A vacuum system is less prone to clogging because, in case of a liner leak, the vacuum pump of the leak detection system will pull the leaking ammonia to the ammonia analyser. Once the leak detection circuit where the leak has occurred has been determined, the leak can be diluted with air reducing or eliminating the risk of clogging via the vacuum pump by opening the atmospheric ball valve.

With a pressurised system each leak detection circuit should contain a flowmeter to verify if there is any flow through the circuit. In case of a leak, the only option available is to increase the setpoint of the flowmeter. However, the amount of air to dilute the leaking fluid will only be marginal and never enough to eliminate the risk for clogging.

### Avoiding pressure build-up and the risk of backflow

A vacuum system does not restrict the leaking flow and does not build up pressure or introduce the risk of backflow. In case of a large liner leak, the vacuum pump of the leak detection system will pull the leaking fluid without any restrictions to the ammonia analyser.

With a pressurised system, each leak detection circuit contains a flowmeter to ensure that there is flow through the circuit. However, in the event of a major spill due to a liner leak, the flowmeter will act as a restriction, with the consequence that there will be a pressure build up in the leak detection circuit and backflow will occur leading to clogging of the leak detection circuits and even other high pressure equipment items connected to the same leak detection system.

### Ammonia analyser requirements

A reliable pressurised system requires a dedicated ammonia analyser for each item of high pressure equipment to be located as close as possible to the flow meters, whereas a vacuum system

needs only one ammonia analyser for all high pressure equipment items and a leak in the tubing will be immediately notified by an increase in the vacuum pressure including an alarm in the DCS.

### Detection of a single leak detection hole

In some cases there may only be one leak detection hole in a liner compartment. A typical location is the man way covers of high pressure equipment.

A pressurised leak detection system cannot work in such a case as it needs at least two leak detection holes per liner compartment; one to enter with the inert gas and one to exit to the analyser.

When using a vacuum system that is not an issue; any leaking fluid is pulled via the leak detection hole towards the ammonia analyser by means of the vacuum pump.

The risk of clogging can be minimised by adding a high pressure alarm near to the leak detection hole. Other precautions include having sufficiently large diameter tubing, proper tracing and insulation and a reliable and accurate ammonia analyser.

### A system that works when there are clogged grooves or no grooves

A liner compartment is defined as the part of a loose liner between four welds connecting the liner material to the carbon steel of the pressure vessel wall. Typically, grooves are machined along these welds, connected to at least two leak detection holes that are optimally situated as far apart as possible from each other.

Note: there are typically two parallel routes for an inert gas to flow from one leak detection hole to another in a liner compartment. However, in some high pressure equipment, mostly older ones, no grooves are installed.

A pressurised leak detection system cannot work when there are no grooves because the liner will be pressed against the carbon pressure vessel wall due to the internal pressure. A vacuum leak detection system, however, still works even when there are no grooves and fluid will pass due to the roughness and tolerances of the two cylinders.

More often, grooves are clogged due to, for example, earlier liner leaks and corrosion, but bad design or fabrication can also be a cause for a clogged groove.

In case one of the grooves is clogged, in a pressurised leak detection system the inert gas will only flow through the other parallel groove. This means there is no direct detection of the liner area and liner welds close to the clogged groove. This means that half of the critical welds are not covered. A vacuum system in that case still covers the maximum liner area and thus all the liner welds.

In case both grooves are clogged, a pressurised leak detection system is no longer reliable, but a vacuum system will still work. ■

# The outlook for urea

Although the urea market has weathered the pandemic relatively well, a significant amount of new capacity is due to come on-stream in the next year or so, and could keep prices depressed unless more Chinese capacity closes.

The urea industry is dominated by several large national markets which between them represent the majority of global consumption; China, India, the United States and Brazil between them consume 75% of the world's urea. China, India and the US are also the three largest producers, but outside of those countries, Russia and the CIS and the Middle East are major producing and exporting regions.

## China

China remains the largest producer and consumer of urea in the world. In 2019 it consumed 37% of all of the 176 million tonnes of urea produced globally. This status came as a result of a concentrated attempt by central government to ensure self-sufficiency in both food and nitrogen fertilizer production. The result of this was however massive overcapacity in urea production and over-application of urea by farmers. From the 13th Five Year Plan (2015-2020), the Chinese government reined back on the country's breakneck industrialisation and began a process

to shift from a primarily industrial-based economy to a more consumer-based one, as well as placing a new focus upon the environment. This has had a momentous effect upon the country's urea industry, as both production and consumption have fallen. According to IFA figures, Chinese urea production peaked in 2015 at 82 million t/a, and by 2019 this had fallen to 67.8 million t/a. Consumption likewise peaked in 2013 at 73.6 million t/a, and by 2019 had fallen to 64.9 million t/a.

On the supply side, there has been a wave of closure of older, less efficient urea capacity. Most of China's urea is based on coal gasification as a feedstock, and newer, larger and more advanced and energy efficient plants are geared towards being able to run on cheaper bituminous coal rather than more expensive anthracite.

On the demand side, agricultural consumption of urea continues to fall as farmers attempt to be more sophisticated in their application of fertilizer and nutrient use efficiency increases. At the same time, though, industrial consumption is

rising, especially for diesel exhaust treatment, and urea-formaldehyde and urea-melamine resins, and over the next few years new industrial demand is expected to roughly balance falls in agricultural demand, keeping Chinese urea demand relatively constant.

China is still building new urea plants; over 9 million t/a of new capacity is due on-stream out to 2025. However, at the same time older capacity is still closing; CRU estimates that over 11 million tonnes of Chinese urea capacity will close over the same period, for a net contraction of 2 million t/a. Coupled with relatively static demand, this means that Chinese urea exports are continuing to fall. China's overcapacity meant that it had become the largest exporter in the world, peaking at 13.7 million t/a of exports in 2015. This fell to 2.4 million tonnes in 2018, before bouncing back to 4.7 million t/a in 2019 and 5.5 million t/a in 2020. Strong buying from India has helped tempt Chinese sellers into the international market. This year the number is expected to be down, to around 3-5 million t/a due to stronger domestic agricultural indicators.

## India

India is the second largest consumer of urea in the world, with demand totalling 31.2 million t/a in 2019. India, like China, had a policy of self-sufficiency in urea produc-



## Rely on Good Experiences.

Your reliable partner through all stages of plant engineering in the fields of waste heat boilers and process gas coolers for nitric acid, ammonia, methanol and other applications.

steinmüller  
engineering  
The Engineers Company

www.steinmueller.com Tel: +49 (0) 2261 / 789 50-0

## CONTENTS

What's in issue 371

## COVER FEATURE 1

Waste gasification

## COVER FEATURE 2

Nitrogen project listing

## COVER FEATURE 3

'Blue' syngas technologies

## COVER FEATURE 4

Improving ammonia plant economics

NITROGEN+SYNGAS  
ISSUE 371  
MAY-JUNE 2021

BCInsight

Southbank House, Black Prince Road  
London SE1 7SJ, England

Tel: +44 (0)20 7793 2567

Fax: +44 (0)20 7793 2577

Web: www.bcinsight.com

www.bcinsightsearch.com

Kima's new urea plant at Aswan, Egypt, which started up in 2020.



PHOTO: STAMICARBON

tion dating back to the 'Green Revolution' of the 1970s and 80s, but unlike China, this lapsed in the mid-1990s as naphtha and natural gas prices rose and along with them government subsidies. The expense of running plants off naphtha led to almost all of India's urea plants being converted to run off natural gas during the 1990s, but shortages of gas supply, especially at times of high power demand, often meant that plants were unable to run at capacity. Lack of gas also forced an effective moratorium on new urea capacity which has only recently been reversed as India built more LNG import terminals. Indian domestic urea production plateaued at 20-22 million t/a, and consequently imports have had to make up the difference, turning the country into the world's largest buyer of urea. Imports reached 7.5 million t/a in 2019, and government figures show that for the 2019-20 fertilizer year, ending in March 2020, imports reached 9.1 million t/a. Full year figures for 2020-21 are likely to be even higher, and for calendar 2020 are estimated at 11 million t/a.

Under nationalist prime minister Narendra Modi, India has decided to reverse this trend and in 2017 set itself the target of

returning to self-sufficiency in urea production via an ambitious \$8.7 billion plan to build several new state-owned urea plants and encouraging new private sector developments. Two private sector initiatives led to Chambal Fertilizers and Chemicals building a new 1.27 million t/a urea plant at its Kota site near Gadepan, which was commissioned in January 2019. However, Matix Fertilizers and Chemicals, which built a new 1.27 million t/a plant in West Bengal to operate using coalbed methane from nearby coal seams, was unable to operate it due to the coal seams not generating as much gas as anticipated. Matix is now expected to come onstream this year, following completion of a pipeline link to an LNG import terminal.

Meanwhile, the five government plants, also all 1.27 million t/a of urea capacity, and all but one of them due to operate on imported LNG, are nearing completion and start-up, after some delays due to the covid pandemic. The first, at Ramagun-

dam, began pilot operations in February 2021, and the second, at Gorakhpur, is due to begin production by July this year. The Barauni and Sandri plants are both due for completion by December 2021. The fifth plant, however, at Talcher, which

will use coal gasification, has faced difficulties, with engineers from EPC contractor Wuhan Engineering unable to travel due to covid and a strained diplomatic atmosphere with China. Completion is still ostensibly set for 2023, but almost certain to slip.

Even so, the four gas-based plants, together with Matix could add 6.4 million t/a of new capacity this year and next, in theory reducing India's import requirements by a corresponding amount. However, India's demand for urea is projected to continue to increase, and could rise by 4 million t/a by 2025.

Because it runs on imported LNG, Indian capacity will also be some of the highest cost urea production in the world.

**Indian capacity will be some of the highest cost urea production in the world.**

### Brazil

Brazil is the world's second largest importer of urea, and this figure has been growing due to shutdowns of domestic capacity. Brazilian imports of urea were 6.7 million t/a in 2020, over 1 million t/a up on 2019, with the last of Petrobras' three domestic urea plants, the 660,000 t/a unit at Araucaria, being idled in January 2020 as part of cost-cutting measures in the financially challenged company. At the same time, demand continues to increase at 4% year on year as Brazilian agriculture expands.

Petrobras had been hoping to find a buyer for Araucaria, and also its part-completed urea plant at Tres Lagoas, which was to have a capacity of 1.2 million t/a when operational, using gas piped across the border from Bolivia. However, in spite of some interest from Russia's Acron, amongst others, no sale has been agreed, and for now Brazil is importing all of its urea requirements.

### Iran

Supply out of Iran is a source of uncertainty in the urea market. Iran has long sought to monetise its huge natural gas reserves via downstream chemical production, with urea and methanol among the major products. Under the Trump administration the US withdrew from an international deal over Iran's nuclear programme and re-imposed sanctions, making exports of urea from Iran more difficult and completion of several urea plants currently under construction more difficult. In spite of that, the Lordegan

urea plant, with a capacity of 1.1 million t/a, began producing urea in late 2020, taking Iranian urea capacity to 7.9 million t/a, and Iran still sells urea to Brazil, Turkey, and some to India and China. However, any new deal and/or substantial lifting of sanctions by the Biden administration could see considerable additional urea available from Iran.

### Rising capacity

Outside of China, India and Iran, there are also a number of new urea plant projects due to come onstream in the next year or so. In Nigeria, Dangote is in the process of commissioning the second of two 1.3 million t/a urea trains, and Indorama Eleme is completing a second 4,000 t/d (1.3 million t/a) urea plant due to come onstream in 2021-22.

In Russia, Metafrax is building a new 570,000 t/a urea plant at the company's Gubakha site, using CO2 from the nearby methanol plant as part of the feed. TogliattiAzot is constructing a third, new 726,000 t/a urea plant at Perm, and KuibyshevAzot is adding a new 540,000 t/a urea plant at Togliatti. EuroChem has announced plans for a 1.32 million t/a urea plant at Kingisepp near St Petersburg, and Shchekinoazot is building a new 660,000 t/a plant in the Tula region, for a potential 3.8 million t/a of urea capacity by 2023.

Outside of Asia, Brunei Fertilizer Industries is also due to complete a new 1.3 million t/a urea plant this year, and there are some other capacity increments at places like Koch's Enid plant in the US. In total, somewhere around 24 million t/a

of new urea capacity is due to come on stream between 2020 and 2025, albeit balanced by those 11 million t/a of closures in China. Set against this net 13 million t/a of new capacity, demand is expected to rise by 13 million t/a over the same period, with India, Africa and South America (especially Brazil) projected to be the fastest growing areas. In theory this means that over the next five years capacity and demand are likely to be balanced, and the continuing effects of the covid epidemic could continue to push back the start dates of a number of projects, potentially tightening the market over the longer term. However, much of the capacity start-ups are front loaded towards the beginning of the period, and could depress urea markets over the next year or so. The large volumes coming from Nigeria in particular could unbalance markets in the short term.

### New regulations

As has been reported by our sister publication *Fertilizer International*, one wrinkle in the picture for urea could be the impact of proposed new environmental regulations in Europe and the UK, which include specifying the coating of urea with inhibitors. Germany has already moved ahead with this, and the UK government is consulting on it with farmers. If this became a Europe-wide move, it could lead to a significant decline in urea consumption. Coating urea with an inhibitor can increase costs to farmers by €40/tonne, without benefiting yield, a rise that could prompt them to make the switch to nitrate-based fertilizers instead. ■



Watch free fertilizer market presentations

Argus deliver concise and insightful webinars analysing the nitrogen, phosphate, potash, sulphur and sulphuric acid markets. The webinars are offered on-demand and live – and are completely free to watch.

Watch the free webinars here: [www.argusmedia.com/webinars](http://www.argusmedia.com/webinars)



[www.nitrogenandsyngas.com](http://www.nitrogenandsyngas.com)

[www.nitrogenandsyngas.com](http://www.nitrogenandsyngas.com)

Nitrogen+Syngas 371 | May-June 2021

Nitrogen+Syngas 371 | May-June 2021

CONTENTS

What's in issue 371

COVER FEATURE 1

Waste gasification

COVER FEATURE 2

Nitrogen project listing

COVER FEATURE 3

'Blue' syngas technologies

COVER FEATURE 4

Improving ammonia plant economics

NITROGEN+SYNGAS  
ISSUE 371  
MAY-JUNE 2021

BCInsight

Southbank House, Black Prince Road  
London SE1 7SJ, England  
Tel: +44 (0)20 7793 2567  
Fax: +44 (0)20 7793 2577  
Web: [www.bcinsight.com](http://www.bcinsight.com)  
[www.bcinsightsearch.com](http://www.bcinsightsearch.com)

# Nitrogen and methanol in the Caribbean



PHOTO: MHTL

Gas availability and pricing continues to affect ammonia and methanol output from Trinidad, while Venezuela struggles with sanctions and political instability.

The Caribbean functions as an adjunct to the North American market for ammonia and downstream nitrates as well as methanol. Trinidad and Venezuela became important suppliers to the US market when US gas prices forced the closure of domestic nitrogen and methanol capacity during the 1990s, but the US shale gas boom has reversed this trend, and in the case of methanol turned the country into a net exporter at the same time that Trinidad and Venezuela face difficulties with production, via maturing gas reserves in Trinidad's case and political disruption and sanctions in Venezuela's

## Trinidad

Although its oil production peaked in the 1970s, Trinidad moved towards exploiting its considerable gas reserves, and became a remarkable success story in

the 1990s on the back of encouraging downstream gas-based industries to set up there, especially export-oriented ammonia, methanol and, in 1998, LNG capacity. Ammonia, methanol and LNG production and export came to occupy 90% of Trinidad's gas output. However, gas production peaked in 2010 at 40 bcm per year, and since then has been in a long slow decline, reaching 31 bcm in 2017, with a slight uptick to 34 bcm in 2019. During 2020, gas output has declined more steeply, falling from 100 million m<sup>3</sup>/day in January to 75 million m<sup>3</sup>/d (equivalent to 27 bcm/year) in November.

The impact of the island's falling gas output has been felt by the companies operating ammonia and methanol capacity there. The Natural Gas Company of Trinidad & Tobago has been trying to renegotiate gas contracts with companies as they come up for renewal, at higher prices to cover the additional cost of drilling further and deeper offshore. However, with cheap gas available just across the Caribbean in the United States, operators have been resisting price hikes and the negotiations have become difficult. As a result, plants have been closing rather than operate at a competitive disadvantage. In April 2021 Methanol Holdings Trinidad Ltd (MHTL), which operates four methanol units on the island, announced that it would be permanently idling two of them; M4 and M5000, after failing to reach a new gas supply agreement, although more recent indications are that an interim agreement may allow them to continue operating until a longer term solution is found. In January 2021 Methanex permanently idled its 875,000 t/a Titan methanol plant. The company's 1.8 million t/a Atlas plant operates under a separate gas supply arrangement which lasts until 2024. If the MHTL plants are not able to continue operation, that would remove 3.3 million t/a of Trinidad's 6 million t/a of methanol capacity from service.

On the ammonia side, Nutrien has shut one of its four ammonia plants permanently and another temporarily. Yara shut down its oldest and smallest plant on the island, Yara Trinidad, in December 2019, and idled another ammonia plant in July 2020. This leaves about 4 million t/a of ammonia capacity out of the 5.5 million t/a that was previously operating, much of it tied into 600,000 t/a of downstream urea and 1.4 million t/a of downstream UAN capacity.

Atlantic LNG has also become a victim of the island's falling gas output. In January 2021 Atlantic idled its 3 million t/a Train 1 for an indefinite period. The company described this as being in "an operations-ready mode" for all of 2021 and 2022. This removes 20% of Atlantic's 14.8 million t/a of LNG capacity. Production was already down 10% in 2020 compared to 2019. The different ownership structure of each of Atlantic's four trains has complicated feedstock allocation since Trinidad's gas production started to decline a decade ago.

Trinidad has five gas basins, three of which – the Trinidad Basin, the Tobago basin, and the Northeast Caribbean Deformed Belt – supply 100% of its gas, about 99% of which is offshore. However, Shell and BHP have been exploring further east in the remote, deepwater T&T North and T&T South blocks and have made some discoveries, although these would require new infrastructure in terms of pipelines to bring to market. However, there are also some other gas developments looking to start-up in the next few

years which may bring some relief. Over the next two years, BHP's Ruby block is expected to be producing 150 million cfd, BP have new gas coming from Matapel and Cassia-C (both 300 million cfd), and Shell's Barracuda and Colibri projects should add 450 million cfd, plus another 300-700 million cfd from Manatee by 2025. These and other prospects such as Touchstone's Cascadura and Ortoire fields could increase gas output by 3 bcf per day by 2030, although many break-even wellhead prices are put at upwards of \$4.00/MMBtu, significantly above the \$2.50/MMBtu that Trinidad tends to charge customers.

There has also long been the prospect of access to Venezuelan gas fields only just across the international sea boundary between the two countries, and at one stage there was to be a joint LNG export project. However, political differences with the Chavez and Maduro regimes in Venezuela has precluded any significant petrochemical cooperation. It is estimated that up to 1 bcf per day of natural gas could be

exported from Venezuela to Trinidad if relations were normalised.

Either way, while the Natural Gas Company of Trinidad & Tobago (NGC) admits that 2021 will be a "challenging" year for gas production, it looks as if the medium to longer term prospects for Trinidad's gas production may be brighter, albeit not necessarily at a price that chemical producers wish to pay.

## New capacity

Table 1 shows the status of Trinidad's ammonia and methanol plants. The most recent has been the Caribbean Gas Chemical Company, a joint venture between NGC, Mitsubishi and Massy Holdings, part of the Proman Group (which also owns Methanol Holdings Trinidad Ltd), which started up a new 1.0 million t/a methanol plant and 100,000 t/a dimethyl ether side stream at Le Brea in December 2020. For the time being, however, the current gas shortages have served to put a hold on new downstream developments.

Table 1: Trinidad's ammonia and methanol capacity

Plant	Owner	Startup	Capacity (t/a)	Status
<b>Ammonia</b>				
Yara Trinidad Ltd	Yara	1959	285,000	Closed
Tringen I	Yara	1977	500,000	Idled
PCS 01	Nutrien	1981	445,000	Idled
PCS 02	Nutrien	1981	600,000	Closed
Tringen II	Yara	1988	495,000	Operating
PCS 03	Nutrien	1996	250,000	Operating
PCS 04	Nutrien	1998	650,000	Operating
Point Lisas Nitrogen	Proman	1998	650,000	Operating
Caribbean Nitrogen Co	Proman	2002	650,000	Operating
Nitrogen 2000	Proman	2004	650,000	Operating
AUM Ammonia	Proman	2009	650,000	Operating
<b>Methanol</b>				
TTMC I (M1)	Proman	1984	480,000	Closed
CMC (M2)	Proman	1993	550,000	Operating
TTMC II (M3)	Proman	1996	570,000	Operating
Methanol IV (M4)	Proman	1998	580,000	Temporary contract
Titan	Methanex	1999	850,000	Idled
Atlas	Methanex	2004	1,700,000	Operating
M5000 (M5)	Proman	2005	1,890,000	Temporary contract
Caribbean Gas Chemical	Mitsubishi/Proman/Trinidad	2020	1,000,000	Operating

Source: Trinidad & Tobago Ministry of Energy Industries

Above: The new Caribbean Gas Chemical methanol and DME plant on Trinidad.

## CONTENTS

What's in issue 371

## COVER FEATURE 1

Waste gasification

## COVER FEATURE 2

Nitrogen project listing

## COVER FEATURE 3

'Blue' syngas technologies

## COVER FEATURE 4

Improving ammonia plant economics

NITROGEN+SYNGAS  
ISSUE 371  
MAY-JUNE 2021

BCInsight

Southbank House, Black Prince Road  
London SE1 7SJ, England

Tel: +44 (0)20 7793 2567

Fax: +44 (0)20 7793 2577

Web: www.bcinsight.com  
www.bcinsightsearch.com

## Exports

Trinidad produced 5.1 million t/a of ammonia in 2020, of which 3.9 million t/a was exported, according to official figures. It also produced and exported 730,000 t/a of urea, 1.4 million t/a of UAN and 30,000 t/a of melamine. Methanol production and export was 4.3 million t/a.

## Venezuela

Oil-rich Venezuela developed its own nitrogen and methanol industries in the 1980s and 90s on the back of associated gas from oil production, run mostly by state-owned Petroquímica de Venezuela (Pequiven) and its subsidiaries. Pequiven has four complexes across Venezuela at El Tablazo, Jose, Paraguana and Moron, which have a total of 2 million t/a of urea capacity and 2.4 million t/a of methanol capacity, the latter split between Methanol de Oriente (Metor) with 1.6 million t/a and 820,000 t/a from Supermetanol, a joint venture with Italy's Eni.

However, Venezuela's economy has been in permanent crisis since 2010, via falling oil prices, falling oil output due to years of underinvestment, corruption, mismanagement, disputed elections, violent street protests and US-led sanctions against the Chavez and Maduro regimes. It is reckoned that the economy has shrunk by 75% over the past decade. In spite of this, Pequiven has managed to keep its urea and methanol plants operating, but often only intermittently. Metor has been the most reliable, but it has been constrained in terms of sales by US sanctions. Last year, Venezuela was reported to be transferring methanol from Metor to tankers via ship to ship transfers near neighbouring Aruba in an attempt to evade US sanctions. Only one urea line is said to be operating at Fertintra to Jose.

## United States

The third major player in the Caribbean nitrogen and methanol industry is the United States, which had been the major export destination for Trinidadian and Venezuelan product until the shale gas

boom of the 2000s and 2010s. This saw US gas production leap to the point where the country is now a gas exporter, and the restart of idled capacity, along with some new plant construction. The largest developments were the construction of huge new ammonia-urea complexes for OCI at Wever, Iowa and CF Industries (now Nutrien) at Donaldsonville, Louisiana and Port Neal, Iowa, which between them added 2.5 million t/a of ammonia, 2.7 million t/a of urea and 2.8 million t/a of UAN capacity. Other plant restarts and new construction added 2.4 million t/a of ammonia and 1.8 million t/a of urea, the most recent being a 750,000 t/a ammonia facility for BASF and Yara

which opened in Texas in 2018, based on off-gases from local petrochemical facilities.

In spite of this, the US remains a net importer of ammonia. In 2020, US government statistics show ammonia production ran at 14.0 million t/a, with fertilizer use the main demand segment. However, consumption stood at 16.0 million t/a for the year, with the

remainder imported, mainly from Canada and Trinidad. As our Nitrogen Project Listing elsewhere this issue shows, aside from some revamps at existing sites, there are no major planned additions to US nitrogen capacity for several years.

## Methanol

The US methanol industry also had a renaissance, with production rising from its low point of 1.0 million t/a in 2005 to 5 million t/a by 2015. This included Methanex's relocation of two plants from Chile, where the company had faced gas curtailments, to Geismar, Louisiana, south of Baton Rouge, adding 2 million t/a of capacity, the restart of LyondellBasell's 800,000 t/a Channelview methanol plant near Houston, Texas, and the 1.3 million t/a Celanese Clear Lake methanol plant in Texas. The addition of the OCI joint venture 1.8 million t/a Natgasoline methanol plant in 2018 took US methanol capacity to 7.8 million t/a.

However, the past few years have seen a slowdown in new project development. Chinese companies had become

very interested in developing US methanol capacity to send cheap shale gas based methanol to China to feed olefins production. But the Northwest Innovations Works plans to build three huge complexes in the Pacific Northwest ran into local opposition and the projects are now all but dead. Yuhuang managed to gain permits for a 1.8 million t/a methanol plant at Lake Charles, Louisiana (YCI Methanol One), and ground was broken in 2015 and construction began in 2017, but the project ran into financial trouble in 2018 and was rescued by Koch Methanol, which eventually took a 60% stake in it in 2019. Delays, cost overruns and permitting issues have all dogged the project, which now may start up this year.

Big Lake Methanol, a Proman development, was looking at a 1.4 million t/a methanol plant in Louisiana, but work has been halted by the covid crisis and financial issues. Methanex planned to build a third plant at its Geismar site, with a capacity of 1.8 million t/a, but put the project on care and maintenance last year due to the covid crisis and weak methanol market. At the moment the only methanol plant due to start up in the US is the 200,000 t/a Liberty One plant at Charleston, West Virginia, a second hand relocated plant from Brazil, which the company says will come on-stream in 2Q 2021.

## A net exporter

The US was a major methanol importer for most of the 2000s and 2010s. In 2010 it imported 5.1 million t/a of methanol, mostly from Trinidad. But the rapid ramp-up of new capacity turned the country into a net exporter in the final months of 2018 (though it was an overall net importer for the year). US methanol production rose to 5.7 million t/a in 2019, up from 5.2 million t/a the year before and the US was now a net exporter to the tune of around 500,000 t/a. However, 2020 saw demand fall in the US and globally, particularly in the first half of the year, boosting US exports, though US methanol producers were forced to look further afield for markets. Overall methanol demand was down about 5% in 2020 and is forecast to recover only slowly over the next two years. Nevertheless, US Gulf Coast methanol production remains lower cost than Trinidadian production, and so in an oversupplied methanol market, US producers may still win out over Trinidad. ■

## Nitrogen project listing 2021

Nitrogen+Syngas's annual listing of new ammonia, urea, nitric acid and ammonium nitrate plants.

Contractor	Licensor	Company	Location	Product	mt/d	Status	Start-up date
<b>AUSTRALIA</b>							
SNC Lavalin	Haldor Topsoe	Perdaman	Karratha, WA	Ammonia	3,500	CA	2024
SNC Lavalin	Saipem	Perdaman	Karratha, WA	Urea	2 x 3,100	CA	2024
Technip FMC	n.a.	Strike Energy	Garaldton, WA	Ammonia	2,400	DE	2025
Technip FMC	n.a.	Strike Energy	Garaldton, WA	Urea	4,200	DE	2025
<b>BANGLADESH</b>							
MHI, CNCIC	Saipem, TKFT	BCIC	Ghorasal Polash	Urea	2,800	UC	2022
<b>BELARUS</b>							
n.a.	Stamicarbon	Grodno Azot	Grodno	Urea	+90	RE	2021
<b>BRAZIL</b>							
n.a.	thyssenkrupp Uhde	Petrobras	Tres Lagoas	Urea	3,600	DE	On Hold
<b>BRUNEI</b>							
thyssenkrupp Uhde	thyssenkrupp Uhde	Brunei Fertilizer Ind.	Sungai Liang	Ammonia	2,200	C	2021
thyssenkrupp Uhde	Stamicarbon, TKFT	Brunei Fertilizer Ind.	Sungai Liang	Urea	3,900	C	2021
<b>CANADA</b>							
Black & Veatch	Stamicarbon	Confidential	n.a.	Urea	+300	RE	2022
<b>CHINA</b>							
n.a.	Casale	Yichang Xingxing	Yichang, Hubei	Ammonia	1,250	UC	2022
n.a.	Casale	Fujian Shen Yuan	Fuzhou	Ammonia	1,200	UC	2021
n.a.	Casale	Henan Xinlianxin	Jiangxi	Ammonia	2,000	UC	2022
n.a.	Stamicarbon	Henan Xinlianxin	Jiangxi	Urea	2,330	DE	2024
n.a.	Casale	Jiangsu Jinmei	Xuzhou	Ammonia	2,000	UC	2022
n.a.	Casale	Chongqing Yihua	Chongqing	Ammonia	900	UC	2022
n.a.	Saipem	Shanxi Qingshui	Yulin, Henan	Urea	3,300	UC	n.a.
Hualu Engineering	Stamicarbon	Jiujiang Xinlianxin	Jiujiang, Jiangxi	Urea	2,330	C	2021
Wuhuan Engineering	Stamicarbon	Hubei Sanning	Hubei	Urea	2,330	C	2021
<b>DENMARK</b>							
n.a.	Haldor Topsoe	Vestas	Jutland	Ammonia	15	CA	2022
n.a.	n.a.	CIP	Esbjerg	Ammonia	910	FS	2026
<b>EGYPT</b>							
Tecnimont	KBR	Kima	Aswan	Ammonia	1,200	C	2020
Tecnimont	Stamicarbon	Kima	Aswan	Urea	1,575	C	2020
thyssenkrupp Uhde	thyssenkrupp Uhde	NCIC	Ain Sokhna	Ammonia	1,200	UC	2022
thyssenkrupp Uhde	Stamicarbon, TKFT	NCIC	Ain Sokhna	Urea	1,050	UC	2022
thyssenkrupp Uhde	thyssenkrupp Uhde	NCIC	Ain Sokhna	Nitric acid	500	UC	2022
thyssenkrupp Uhde	thyssenkrupp Uhde	NCIC	Ain Sokhna	Ammonium nitrate	635	UC	2022
thyssenkrupp Uhde	thyssenkrupp Uhde	NCIC	Ain Sokhna	CAN	835	UC	2022
Tecnimont	KBR	EHC	Ain Sokhna	Ammonia	1,320	CA	2023
n.a.	Stamicarbon	Abu Qir Fert	Abu Qir	Urea	2,370	RE	n.a.

## KEY

BE: Basic engineering  
C: Completed/commissioning  
CA: Contract awarded

DE: Design engineering  
FS: Feasibility study  
n.a.: Information not available

P: Planned/proposed  
RE: Revamp  
UC: Under construction

Conversion:  
1 t/d of hydrogen = 464 Nm<sup>3</sup>/h  
1 t/d of natural gas = 1,400 Nm<sup>3</sup>/h

## CONTENTS

What's in issue 371

## COVER FEATURE 1

Waste gasification

## COVER FEATURE 2

Nitrogen project listing

## COVER FEATURE 3

'Blue' syngas technologies

## COVER FEATURE 4

Improving ammonia plant economics

NITROGEN+SYNGAS  
ISSUE 371  
MAY-JUNE 2021

BCInsight

Southbank House, Black Prince Road  
London SE1 7SJ, England

Tel: +44 (0)20 7793 2567

Fax: +44 (0)20 7793 2577

Web: www.bcinsight.com  
www.bcinsightsearch.com

Contractor	Licenser	Company	Location	Product	mt/d	Status	Start-up date
<b>GERMANY</b>							
n.a.	Haldor Topsoe	AQM Capital	n.a.	Ammonia	300	P	2024
<b>HUNGARY</b>							
n.a.	Casale	BorsodChem	Kazincbarcika	Nitric acid	660	UC	2022
<b>INDIA</b>							
Engineers India Ltd	Haldor Topsoe	RCFL	Ramagundam	Ammonia	2,200	C	2020
Engineers India Ltd	Saipem	RCFL	Ramagundam	Urea	3,850	C	2020
n.a.	Casale	Zuari AgroChem	Goa	Ammonia	1,050	RE	2022
TechnipFMC/L&T	Haldor Topsoe	HURL	Sindri	Ammonia	2,200	UC	2021
TechnipFMC/L&T	Saipem	HURL	Sindri	Urea	3,850	UC	2021
TechnipFMC/L&T	Haldor Topsoe	HURL	Barauni	Ammonia	2,200	UC	2021
TechnipFMC/L&T	Saipem	HURL	Barauni	Urea	3,850	UC	2021
n.a.	KBR	HURL	Gorakhpur	Ammonia	2,420	UC	2021
n.a.	TEC	HURL	Gorakhpur	Urea	3,850	UC	2021
n.a.	Saipem	NFL	Vijaipur	Urea	2 x 1,515	RE	n.a.
n.a.	Saipem	Coromandel	Gadepan	Urea	1,650	RE	n.a.
n.a.	Casale	Deepak Fertilizers	Paradip	Nitric acid	970	C	2020
Wuhuan Engineering	KBR	Talcher Fertilizers	Talcher	Ammonia	2,200	UC	2023
Wuhuan Engineering	Stamicarbon	Talcher Fertilizers	Talcher	Urea	3,850	UC	2023
<b>INDONESIA</b>							
n.a.	thyssenkrupp Uhde	Bakrie	Kalimantan	Nitric acid	750	DE	On hold
n.a.	thyssenkrupp Uhde	Bakrie	Kalimantan	Ammonium nitrate	900	DE	On hold
<b>IRAN</b>							
PIDEC	Casale	Masjid Soleyman	Masjid Soleyman	Ammonia	2,050	UC	On Hold
PIDEC	n.a.	Masjid Soleyman	Masjid Soleyman	Urea	3,250	UC	On Hold
Hampa	Casale	Zanjan Petrochemical	Zanjan	Ammonia	2,050	UC	On Hold
Hampa	Stamicarbon	Zanjan Petrochemical	Zanjan	Urea	3,600	UC	On Hold
Namvaran	KBR	Kermanshah Petchem	Kermanshah	Ammonia	2,400	UC	On Hold
Namvaran	Stamicarbon	Kermanshah Petchem	Kermanshah	Urea	2,000	UC	On Hold
PIDEC	Haldor Topsoe	Hengam Petrochemical	Assalyueh	Ammonia	2,050	UC	n.a.
PIDEC	Saipem, TKFT	Hengam Petrochemical	Assalyueh	Urea	3,500	UC	n.a.
<b>ISRAEL</b>							
Saipem	Haldor Topsoe	Haifa Negev Tech Ltd	Mishor Rotem	Ammonia	300	DE	2023
<b>NETHERLANDS</b>							
OCI Nitrogen	Stamicarbon	OCI Nitrogen	Geleen	Urea	n.a.	C	2020
<b>NIGERIA</b>							
TEC	KBR	Indorama	Port Harcourt	Ammonia	2,300	C	2020
TEC	TEC	Indorama	Port Harcourt	Urea	4,000	C	2020
Saipem	Haldor Topsoe	Dangote Fertilizer Ltd	Agenbode	Ammonia	2 x 2,200	C	2021
Saipem	Saipem/TKFT	Dangote Fertilizer Ltd	Agenbode	Urea	2 x 3,850	C	2021
n.a.	n.a.	OCP	n.a.	Ammonia	3,300	P	2024

**KEY**  
 BE: Basic engineering DE: Design engineering P: Planned/proposed Conversion:  
 C: Completed/commissioning FS: Feasibility study RE: Revamp 1 t/d of hydrogen = 464 Nm<sup>3</sup>/h  
 CA: Contract awarded n.a.: Information not available UC: Under construction 1 t/d of natural gas = 1,400 Nm<sup>3</sup>/d

Contractor	Licenser	Company	Location	Product	mt/d	Status	Start-up date
<b>POLAND</b>							
thyssenkrupp Uhde	thyssenkrupp Uhde	Grupa Azoty	Pulawy	Nitric acid	1,000	UC	2022
thyssenkrupp Uhde	thyssenkrupp Uhde	Grupa Azoty	Pulawy	Ammonium nitrate	1,300	UC	2022
thyssenkrupp Uhde	thyssenkrupp Uhde	Anwil SA	Wloclawek	Nitric acid	1,265	UC	2022
thyssenkrupp Uhde	thyssenkrupp Uhde	Anwil SA	Wloclawek	Ammonium nitrate	1,500	UC	2022
Tecnimont	Stamicarbon						
<b>RUSSIA</b>							
Tecnimont	Stamicarbon	KuibishevAzot	Togliatti	Urea	1,500	UC	2021
GIAP	Casale	KuibishevAzot	Togliatti	Nitric acid	1,350	UC	2021
GIAP	Casale	KuibishevAzot	Togliatti	Ammonium nitrate	1,500	UC	2021
NIIK	Casale	JSC Metafrax	Gubakha	Ammonia	1,000	UC	2021
NIIK	Casale/MHI	JSC Metafrax	Gubakha	Urea	1,700	UC	2022
Casale	Casale	Togliatti Azot	Togliatti	Urea	2,200	UC	2022
Tecnimont	KBR	EuroChem	Kingisepp	Ammonia	3,000	UC	2024
Tecnimont	Stamicarbon	EuroChem	Kingisepp	Urea	4,000	UC	2024
Uralchem	Stamicarbon	Uralchem	Perm	Urea	+900	RE	On Hold
n.a.	KBR	Kemerovo Azot	Kemerovo	Nitric acid	500	UC	2021
Acron	GIAP	Acron	Dorogobuzh	Ammonia	2,100	C	2020
NIIK	Stamicarbon	Acron	Novgorod	Urea	2,000	C	2020
CNCCC	Haldor Topsoe	ShchekinoAzot	Pervomayskyy, Tula	Ammonia	1,500	DE	2022
CNCCC	Stamicarbon	ShchekinoAzot	Pervomayskyy, Tula	Urea	2,000	DE	2022
<b>SAUDI ARABIA</b>							
Daelim	thyssenkrupp Uhde	Ma'aden	Ras al Khair	Ammonia	3,300	UC	2022
n.a.	Haldor Topsoe	Neom	Neom	Ammonia	3,500	CA	2025
<b>SOUTH KOREA</b>							
thyssenkrupp Uhde	thyssenkrupp Uhde	Hu-Chems	Yeosu	Nitric acid	1,150	BE	2023
<b>TRINIDAD &amp; TOBAGO</b>							
n.a.	Casale	PCS Nitrogen	Point Lisas	Ammonia	1,600	RE	2021
<b>TURKEY</b>							
Tecnimont	Stamicarbon	Gemlik Gubre	Gemlik	Urea	1,640	DE	2023
Tecnimont	n.a.	Gemlik Gubre	Gemlik	UAN	500	DE	2023
<b>UNITED KINGDOM</b>							
n.a.	JM	CF Industries	Billingham	Ammonia	1,500	RE	2020
<b>UNITED STATES</b>							
Black & Veatch	Stamicarbon	Confidential	n.a.	Urea	+660	RE	2022
PCS Nitrogen	Stamicarbon	Confidential	n.a.	Urea	+250	C	2020
n.a.	Stamicarbon	Confidential	n.a.	Urea	+540	RE	2024
n.a.	KBR	Monolith Materials	Hallam, Nebraska	Ammonia	830	CA	2024
<b>UZBEKISTAN</b>							
MHI	Haldor Topsoe	NavoijAzot	Navoij	Ammonia	2,000	C	2020
MHI	Saipem, TKFT	NavoijAzot	Navoij	Urea	1,750	C	2021
n.a.	Casale	NavoijAzot	Navoij	Nitric acid	1,500	C	2020

**KEY**  
 BE: Basic engineering DE: Design engineering P: Planned/proposed Conversion:  
 C: Completed/commissioning FS: Feasibility study RE: Revamp 1 t/d of hydrogen = 464 Nm<sup>3</sup>/h  
 CA: Contract awarded n.a.: Information not available UC: Under construction 1 t/d of natural gas = 1,400 Nm<sup>3</sup>/d

## CONTENTS

What's in issue 371

## COVER FEATURE 1

Waste gasification

## COVER FEATURE 2

Nitrogen project listing

## COVER FEATURE 3

'Blue' syngas technologies

## COVER FEATURE 4

Improving ammonia plant economics

NITROGEN+SYNGAS  
**ISSUE 371**  
 MAY-JUNE 2021

**BCInsight**

Southbank House, Black Prince Road  
 London SE1 7SJ, England

Tel: +44 (0)20 7793 2567

Fax: +44 (0)20 7793 2577

Web: www.bcinsight.com  
 www.bcinsightsearch.com

Enerkem's municipal waste gasification plant at Edmonton, Alberta.



PHOTO: ENERKEM

# Syngas from waste

Gasification technology offers the promise of being able to convert the increasing volumes of municipal waste generated by society into useful chemical products. In spite of a patchy commercial record, interest in the process remains high.

How to deal with the waste generated by modern society remains a vexed issue for governments all over the world. OECD figures indicate that the average citizen of a developed country produces 540 kg of so-called municipal solid waste (MSW) every year, and this has been a near constant figure over the past two decades. In spite of advances in recycling rates, the European Union reckons that only about 50% of all MSW is currently recycled, with the rest going to landfill or incineration. In the US the figure is only 35%. But landfill sites are filling up, and opportunities for export of waste to other countries to deal with are becoming more limited. China, which used to take large volumes of MSW, banned solid waste imports in 2018. Landfills also generate methane from the breakdown of organic matter, and there is an increasing focus these days on methane as a greenhouse gas. The US alone produces approximately

130 million t/a of CO<sub>2</sub> equivalent in methane escapes from landfill.

Incineration allows the recovery of energy from MSW, which often contains products such as paper, food waste and plastics with a high calorific value, and when coupled to power generation can produce up to 550 kWh of electricity per tonne. However, the variable nature of MSW means that its incineration can also produce a number of toxic by-products including dioxins, furans, polycyclic aromatic hydrocarbons, and oxides of sulphur and nitrogen.

Combusting it in an enclosed system allows for easier removal of by-products, and also generates more energy – up to 1,000 kWh per tonne. Furthermore, waste gasification also generates syngas which can be used for the production of hydrogen or higher value downstream products such as ammonia, methanol and synthetic fuels or plastics. Gasification is also able to deal with some of the more intractable

elements of MSW which cannot be recycled, including non-recyclable plastics like polycarbonates.

## Commercial operation

In spite of its promise, the commercial history of waste gasification has been patchy to say the least, with a number of high profile project failures and bankruptcies, the most prominent of which was the Air Products and AlterNRG Tees Valley 1 and 2 plants in the UK, which were abandoned during construction and which cost Air Products a write down of a reported \$1 billion. Companies involved are often small and cannot absorb the cost of often lengthy permitting delays – inevitable as the facilities are usually in or near urban areas. The variable quality of MSW can also be a challenge for gasifiers, and dealing with waste products like tar and ash contaminated with heavy metals can pose a technical challenge. For this reason

there are often far more small scale pilot and demonstrator plants than large scale commercial operations. Nevertheless, progress has been made, and interest in the technology continues to increase.

## Enerkem

One of the most prominent proponents of waste to chemicals has been Canada's Enerkem. After successful pilot and demonstrator plant trials the company moved to a large scale 100,000 t/a waste gasification-based plant in Edmonton, Alberta. The plant was completed in 2014 at a cost of US\$60 million and takes MSW from the city of Edmonton under a 25 year contract – the city also provided 40% of the funding. The plant deals with 30% of the city's waste, and produces 33,000 t/a of methanol and ethanol.

The company has next moved to develop an even larger waste to methanol plant at Varennes in Quebec. In the \$670 million project it is partnered by Shell, Suncor and Proman, as well as the Quebec provincial and Canadian federal governments. The project aims to use more than 200,000 t/a of non-recyclable and wood waste to produce 100,000 t/a of methanol and ethanol. The project will also include an 87 MW electrolyser to generate renewable hydrogen and oxygen from hydroelectric power to feed the plant.

The company is also part of the W2C (Waste to Chemicals) methanol project in Rotterdam, along with Shell, Air Liquide, Nouryon and the Port of Rotterdam. The project originally envisaged processing 360,000 t/a of MSW into 220,000 t/a of methanol, with a start-up in 2022, although it is now evaluating biomass feeds as well and no final investment decisions has yet been taken. There is also a partnership with Suez to develop a 400,000 t/a waste to methanol plant at Tarragona in Spain. Again no final investment decisions has yet been taken.

## United Kingdom

The UK is facing a shortage of landfill sites, and in the early 2010s became very interested in waste to syngas projects as a potential way of dealing with its solid waste problem. However, while several small biomass gasification plants processing waste wood have successfully started up in the past few years, municipal waste gasification plants have had a much more difficult history, as mentioned above, particularly the Tees Valley (TV) 1 and 2 plants

at Billingham, developed by Air Products in conjunction with AlterNRG's plasma gasification technology, which would have processed 700,000 t/a of waste from the northeast of England to generate 100 MW of power from syngas. However, technical difficulties with the gasification system led to the project being abandoned in 2016.

Likewise UK-based Energos, which developed a successful waste gasification demonstrator plant in Norway, planned three projects in the UK, but went into administration in 2016. The Milton Keynes project has since proceeded but abandoned the use of gasification in favour of incineration, the Derby project was abandoned in 2019 due to technical difficulties, and after some years in legal limbo the Glasgow project was finally denied planning permission in March 2021.

So far the only notable municipal waste gasification project in the UK has been a much smaller scale 40 t/d demonstrator plant has begun operations in the West Midlands, developed by Kew Technology, to produce 1.5 MW of electricity. However, there are still projects on the drawing board, as detailed below.

## Velocys

Velocys, formerly the Oxford Catalysts Group, has developed a Fischer-Tropsch gas to liquids process which it is seeking to couple to renewable syngas generation from biomass or municipal waste. The company has had many ups and downs over the past few years, but in addition to a biofuel gasification plant in the US, says that it remains committed to a UK-based project to convert municipal waste into aviation fuel via Fischer-Tropsch conversion of waste-derived syngas, using technology licenses from Air Liquide, Linde and Haldor Topsoe. However, project timescales have now been put back to completion in 2025.

## Fulcrum

Potentially stealing a march on Velocys is US-based Fulcrum BioEnergy, who have been operating in conjunction with BP and Johnson Matthey (JM). Fulcrum has been working on two projects. The first, at the Sierra BioFuels Plant in Storey, Nevada, is designed to convert 175,000 t/a of household waste into 37,000 t/a of Fischer-Tropsch derived fuel. The project has been delayed but is now in the late stages of construction, and is due to start up this year.

The other major Fulcrum project currently under development is based in the UK, and recently completed site selection – it will be based at the Essar Oil refinery at Stanlow near Liverpool. Construction on Fulcrum NorthPoint, as the project is known, is expected to begin in late 2023 and will be completed in 2025. It will process "several hundred thousand tonnes" of pre-processed waste into 30 million gallons per year of low-carbon aviation fuel.

## Eastman

Eastman Chemicals has operated a coal gasification-based methanol plant at Kingsport, Tennessee for more than 25 years. However, in 2019 it decided to branch out into recycling unrecyclable plastics via two technologies. One, Polyester Renewal Technology, is a chemical breakdown of polyester using glycolysis. The other, Carbon Renewal Technology, effectively tips unrecyclable plastic waste into the gasifier as a co-feed to produce methanol, which can then be used to make acetic acid or formaldehyde and then downstream plastics. The company has set itself the target of recycling 250,000 t/a of plastics via these methods by 2030 and achieving net zero carbon emissions.

## MGC

Mitsubishi Gas Chemical recently announced that it is developing technology to produce methanol by using CO<sub>2</sub> emitted from factories and power plants, as well as gasified plastic waste. The company will modify an existing pilot facility in Japan for this, and intends to begin licensing the technology in 2022 or 2023.

## MyRechemical

In November last year, Maire Tecnimont launched a dedicated subsidiary dedicated to the processing of non-recyclable plastics and refuse derived fuel (RDF) and their conversion into downstream chemicals, which it calls MyRechemical. According to the company, MyRechemical will use a mixture of Tecnimont proprietary technologies with those licensed from other companies for the chemical conversion of carbon and hydrogen in waste via partial oxidation and subsequent purification, from which a low carbon syngas is obtained, able to be converted with process extension into hydrogen, methanol, ethanol and derivatives.

## CONTENTS

What's in issue 371

## COVER FEATURE 1

Waste gasification

## COVER FEATURE 2

Nitrogen project listing

## COVER FEATURE 3

'Blue' syngas technologies

## COVER FEATURE 4

Improving ammonia plant economics

NITROGEN+SYNGAS  
**ISSUE 371**  
 MAY-JUNE 2021

**BCInsight**

Southbank House, Black Prince Road  
 London SE1 7SJ, England

Tel: +44 (0)20 7793 2567

Fax: +44 (0)20 7793 2577

Web: www.bcinsight.com  
 www.bcinsightsearch.com

**Plasma gasification**

One of the issues with conventional gasification technologies is the variable quality of MSW, even after sorting and pre-processing. As well as ash, it also generates tars which must be cleaned from the gasifier. One solution is to increase the temperature drastically to break down molecules completely into a free plasma. This is achieved using an electric arc discharge to create a plasma torch which reduces tar formation (to around 0.1% of an autothermal gasification process) and converts all of the organic material into syngas. Arc discharges obtain thermal plasmas from DC or AC current or through radio frequency or microwaves. DC plasma technology is preferred for waste gasification plasma processes. Plasma is formed by high energy from AC or DC sources through the plasma torch close to the bottom of reactor and fuels are gasified through the plasma flames. The oxygen demand in this process is small compared to conventional gasification since most of the thermal energy is coming from an external energy source rather than exothermic reactions between the fuel and oxygen. There are several companies with pilot facilities, and some have proceeded to full commercialisation of the technology.

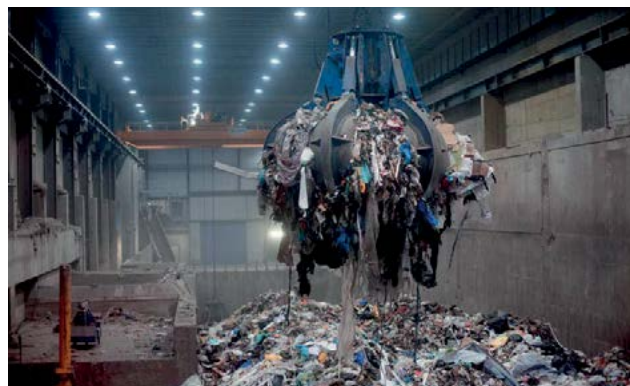

Inside the Fortum waste to energy plant in Oslo.

PHOTO: FORTUM

Impurities are trapped in a bath of molten glass and recovered as ingots, while lighter elements emerge as syngas. The company has six installations so far. In Japan, they process waste electronics, circuit boards and asbestos, mainly using the syngas to generate power, while in Taiwan a site processes batteries and medical waste. Dow Corning operates one at its Midland, Michigan site, which processes untreated industrial waste and uses the hydrogen in hydrochloric acid production, and at Colombia Ridge, Oregon, InEnTec operates a plant processing MSW and produces 1.5 t/d of fuel cell grade hydrogen with the aim of using it to fuel 2,500 vehicles.

**OMNI CT**

The OMNI Conversion Technologies (CT) gasification and plasma refining system is the development of a Canadian company whose proprietary technology was demonstrated in a 135 t/d pilot facility built in 2007 in Austria. Like InEnTec, it is based around a modular system, although slightly larger at 200 t/d of waste input to produce 15 t/d of hydrogen or a larger equivalent volume of syngas. After feed preparation (shredding into 10cm chunks) the waste passes first into a horizontal moving grate gasifier and then a vertical fixed bed updraft gasifier. The plasma flame is only then applied in the presence of oxygen to refine the syngas and remove tars. A final gas cooling and conditioning section removes HCl, sulphur and heavy metals. Around 90% of the energy required to run the system comes from the waste itself, rather than consuming electricity, making it

80% more efficient than water electrolysis in production of hydrogen. In April 2021, OMNI CT announced its first commercial sale of the process, to the Larsen and Lam Climate Initiative in California, for \$35 million.

**A developing area**

In spite of the technical and commercial hurdles, waste gasification is seen as a solution to an otherwise intractable problem of how to deal with large volumes of municipal waste that cannot be recycled, and potentially an element in the 'circular economy', as well as a way of eliminating or at least reducing methane emissions from landfill sites. If some of the steps have been faltering so far, the success of some installations, such as Enkern in Edmonton, shows that it can be done at scale. Gasification of alternative feedstocks has often foundered on the issue of the cost of gathering together sufficient material to run a large-scale plant with associated economies of scale. This has particularly bedevilled biomass gasification projects, except those using waste streams from forestry, pulp and paper production, where the gathering has already been done. Municipal waste however already had had the gathering performed, and already represents 1.3 billion t/a of raw material globally, sufficient to generate more methanol, ammonia and hydrogen combined than current world demand. The entrance of players such as Mitsubishi Gas Chemicals and Maire Tecnimont into the arena shows that major licensors are taking this seriously. ■



**WE KNOW OUR WAY AROUND ENGINEERING**

Think about thousands of highly skilled professionals with distinctive competences and technological know-how operating in the hydrocarbon processing sector. Petrochemicals, oil&gas refining and fertilizers are our core industries, while we aim at accelerating the world energy transition through low carbon technologies and green chemistry.

This is **Maire Tecnimont Group**: a plant engineering leader focused on the chemical processing of conventional and renewable energy resources into advanced products embedded in everyday life.

**45** COUNTRIES

**~1500** TOTAL DELIVERED PROJECTS

**50** COMPANIES

[www.mairetecnimont.com](http://www.mairetecnimont.com)



CONTENTS

What's in issue 371

COVER FEATURE 1

Waste gasification

COVER FEATURE 2

Nitrogen project listing

COVER FEATURE 3

'Blue' syngas technologies

COVER FEATURE 4

Improving ammonia plant economics

NITROGEN+SYNGAS  
**ISSUE 371**  
MAY-JUNE 2021

**BCInsight**

Southbank House, Black Prince Road  
London SE1 7SJ, England  
Tel: +44 (0)20 7793 2567  
Fax: +44 (0)20 7793 2577  
Web: [www.bcinsight.com](http://www.bcinsight.com)  
[www.bcinsightsearch.com](http://www.bcinsightsearch.com)



# Blue technologies in the transition to lower carbon footprint

Reducing the carbon footprint in the synthesis of chemicals is a new global challenge as the world works towards providing sustainable products designed to minimise their environmental impacts throughout their whole lifecycle. This article looks at the role of blue technologies as part of a roadmap towards the decarbonisation of fuels and chemicals.

The declared commitment of governments, companies and other institutions to climate neutral production of goods and carbon-free transportation makes it necessary to have an energy carrier that does not contain carbon and offers a competitive energy density compared to today's solutions.

In the transition towards completely decarbonised fuels, blue hydrogen and blue ammonia – whose production involves carbon capture and sequestration (CCS) or carbon capture and utilisation (CCU) – represent an attractive prospect.

The primary "blue" feedstocks, natural gas and coal, currently set the low cost benchmarks for storable energy commodities. With the addition of CCS, they are expected to set the low cost benchmarks for low carbon storable energy commodities.

Definitions have not been standardised yet. Some important aspects such as how much CO<sub>2</sub> sequestration is needed to call a product "blue" and the boundaries of the carbon emission analysis still need to be defined in international standards.

Ammonia is the second most widely produced commodity chemical globally, with a production volume of over 180 million tonnes in 2019, and with approximately 20 million tonnes per year traded as merchant ammonia (mostly in the form of seaborne trade), mostly utilised in agriculture as a fertilizer, a sector that is under increasing scrutiny due to its environmental impact. Ammonia is one of the most energy intensive chemical products, responsible for the emission of large quantities of CO<sub>2</sub>.

Ammonia can be synthesised from nitrogen and hydrogen via various methods, with the Haber-Bosch process currently the only method used on a commercial scale. The resulting ammonia can be easily transported, stored and the hydrogen can be extracted again at the destination via a thermal decomposition and separation process.

There are basically two routes to reduce carbon dioxide emissions: the first is to capture and sequester generated CO<sub>2</sub>, resulting in so-called "blue" products; the second is to totally avoid CO<sub>2</sub> generation by the use of renewable energy and feedstocks, resulting in so-called "green" products.

This article will focus on blue technologies. Green technologies will be featured in the November-December issue of *Nitrogen+Syngas*.

## Ammonia as a marine fuel

When it comes to alternatives in the field of marine fuels (with IMO's target of a 50% reduction in annual GHG emissions from international shipping by 2050<sup>1</sup>) the use of ammonia as a substitute to heavy fuel oil gains importance, with the first ammonia fuelled ship already under construction. The growth of this supplementary market for ammonia is expected to become substantial: starting with 10 Mt/year in 2025 the use of ammonia as fuel will increase to 150 Mt/year in 2050<sup>2</sup>. It is obvious, that such an increase in ammonia production – in addition to the high and stable demand in the fertiliser industry – cannot be realised solely by future green ammonia plants. The gap has to be closed, at

least in the beginning, by blue ammonia production, which is still based on the use of carbon containing natural gas.

## Hydrogen as an energy carrier

Hydrogen and its use as an energy carrier is a hot topic and many economies are starting to transform their energy basis from carbon based feedstocks to hydrogen and are planning to build a hydrogen economy. Hydrogen can be produced from hydrocarbons through steam methane reforming (SMR), autothermal reforming (ATR), partial oxidation (POx), methane pyrolysis or by water electrolysis.

Presently, most hydrogen is produced industrially from the steam reforming (>95%) of natural gas and emits CO<sub>2</sub>. Reducing direct emissions of CO<sub>2</sub> and methane will determine whether the industry retains the right to operate in the future. Low-carbon technology and processes required to achieve near net-zero emissions exist and are well proven. To be a near zero carbon emission technology, the captured CO<sub>2</sub> needs to be permanently stored. The economics and sustainability of CO<sub>2</sub> storage remains uncertain in many cases and may not be available locally.

Historically, the standard process steps for hydrogen generation consisted of a steam reformer, high temperature and low temperature shift conversion, CO<sub>2</sub> removal via absorption and methanation for final purification. After the introduction of PSA technology in the mid 1960s and rapid adoption of the technology since the early 1970s, the standard process changed to

PSA technology rather than CO<sub>2</sub> removal. However, the concept of applying CO<sub>2</sub> removal units in hydrogen plants is a well-proven and mature concept which has been applied for decades. The concept of CO<sub>2</sub> removal from process gas is applied in the front-end of ammonia plants which is very similar to the design of a SMR based hydrogen plant.

Blue hydrogen is often discussed for providing substantial amounts of hydrogen of more than several hundred thousand normal cubic metres per hour. This is particularly interesting for large scale consumers, such as steel production plants and large chemical production sites, which have a significant demand for hydrogen and require a continuous, uninterrupted supply. For example, the thyssenkrupp steel mill in Duisburg, Germany will use hydrogen in blast furnaces and in direct reduced iron plants for replacing coke in its steel production process. Blue hydrogen production closes the gap between the current carbon based economy and an economy entirely relying on green hydrogen as a long term solution.

## Current ammonia technology

Reforming based ammonia production has two places where carbon from the natural gas is converted to carbon dioxide: On the process side, it is derived from the reforming and water gas shift reactions. In a conventional plant, it accounts for about 1.2 t CO<sub>2</sub>/t ammonia. On the flue gas side, it is a result of natural gas combustion for heat release and for a steam methane reformer (SMR) based plant amounts to about 0.5 t CO<sub>2</sub>/t ammonia for the primary reformer.

For a plant with an autothermal reformer (ATR), the total CO<sub>2</sub> production is

about the same, but with a different split between the two emission sources. Since heating for the reforming reaction in the ATR is provided by internal combustion of a part of the feed gas, the process gas contains and releases more CO<sub>2</sub> and the required fired heater emits less than the steam methane reformer (see Fig. 1).

## Blue ammonia

The major part of the CO<sub>2</sub> in an SMR or ATR plant comes sequestration-ready as the CO<sub>2</sub> has to be removed from the process gas anyway. Various technologies from different licensors are available. The CO<sub>2</sub> removal unit in an ammonia plant usually produces a CO<sub>2</sub> stream of >99% purity. Instead of venting it to the atmosphere, it is compressed to the required pressure level of the receiving system (approx. 130 to 160 bar), possibly dried and sequestered underground for final disposal.

The required installations for this can be added to any existing ammonia plant and can address about two thirds of the CO<sub>2</sub> reduction potential as can be seen from the numbers above and from Fig. 1. If ammonia is intended to be used as a marine fuel, the CO<sub>2</sub> emissions from it are thus already significantly below those of methane or diesel.

However, further reduction is possible by also treating the flue gas from the primary reformer or the fired heater. Several technologies exist, but as it is not a mandatory step in ammonia production, only a few reference installations exist today. For details refer to the following section on CO<sub>2</sub> removal from flue gas. Fig. 1 shows the further reduction in CO<sub>2</sub> emission if the flue gas is also treated to remove 90% of the CO<sub>2</sub> contained in it. The figures for the

process variants with CO<sub>2</sub> capture include the additional energy for flue gas scrubbing and CO<sub>2</sub> compression. It can be covered fully or to a large extent from the excess steam production from waste heat of the ammonia plant.

The flue gas CO<sub>2</sub> removal unit can be installed in a new plant or as a revamp, and the recovered CO<sub>2</sub> can be mixed with the separated CO<sub>2</sub> from the process gas for compression and sequestration.

Of course, large-scale urea production which consumes CO<sub>2</sub> as a mandatory feed stock cannot be combined with blue ammonia. However, the blue ammonia process (by revamp or by new design) does not have any impact on other downstream processes like nitric acid or ammonium nitrate production. These products inherit the low CO<sub>2</sub> emission status from the ammonia they are made of.

## CO<sub>2</sub> removal technologies

Although the separation of CO<sub>2</sub> from the pressurised synthesis gas by a scrubbing system is a very mature technology there are ways to improve the recovery rate and to lower the specific energy consumption, in order to lower overall carbon emissions. Improvements include an innovative process layout with additional vessels for enhanced recovery, flash gas recycle, new solvent formulations and high-performance column internals for improved mass transfer and lower pressure drop.

Compared to the CO<sub>2</sub> removal unit in the process, the challenges of removing CO<sub>2</sub> from flue gas are due to the fact that flue gas contains many substances such as NOx, SO<sub>2</sub>, and O<sub>2</sub>, which are detrimental to the solvents usually used for the process gas treatment, like amine solutions. Further,

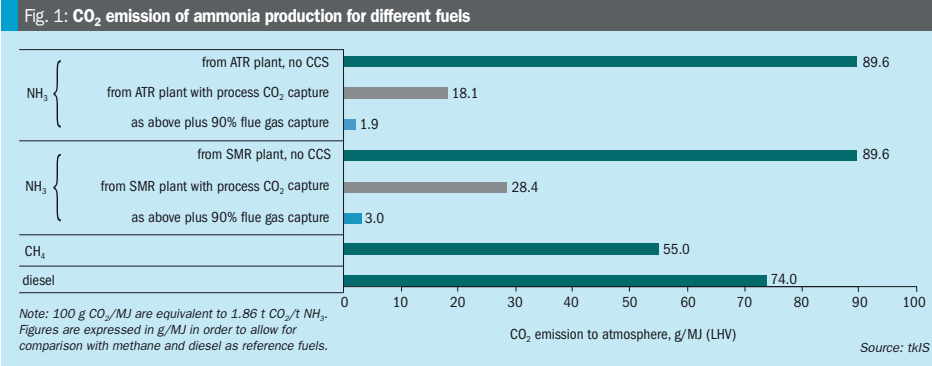

CONTENTS

What's in issue 371

COVER FEATURE 1

Waste gasification

COVER FEATURE 2

Nitrogen project listing

COVER FEATURE 3

'Blue' syngas technologies

COVER FEATURE 4

Improving ammonia plant economics

NITROGEN+SYNGAS  
ISSUE 371  
MAY-JUNE 2021

BCInsight

Southbank House, Black Prince Road  
London SE1 7SJ, England  
Tel: +44 (0)20 7793 2567  
Fax: +44 (0)20 7793 2577  
Web: www.bcinsight.com  
www.bcinsightsearch.com

due to the lower partial pressure of the flue gas (close to ambient pressure) the driving force for the absorption is less. Therefore, for flue gas only a lower degree of CO<sub>2</sub> separation can be achieved economically.

Typically, in such a unit the flue gas is pre-treated first in a scrubbing column. By intensive contact with circulating water, the flue gas is cooled and sulphuric gas components are removed from the gas. Subsequently the CO<sub>2</sub> absorber column facilitates the separation of CO<sub>2</sub> from the flue gas. The carbon dioxide is separated by means of an aqueous amine solution, which in turn is regenerated in a stripper column. In this column, the CO<sub>2</sub> is released, cooled and routed to downstream compression.

For CO<sub>2</sub> capture an amine blend is used containing a small amount of an activator component. The unit is designed for a CO<sub>2</sub> capture rate of about 90%. Low pressure steam is used for the solvent regeneration. Backwashing sections in the top of the absorber and of the stripper column assure a high degree of solvent recovery and minimise solvent losses.

Ammonia licensor thyssenkrupp provides a proprietary process for CO<sub>2</sub> capture from flue gas for revamps and for new built ammonia plants. The technology has been intensively investigated at pilot plant scale with steel mill gases and flue gas at thyssenkrupp's multi-purpose testing facility. The Carbon2Chem® project and the sophisticated test centre is aimed at the chemical use of syngas and CO<sub>2</sub> derived from steel mill gases for the production of ammonia/urea, methanol and other valuable chemical products<sup>3, 4</sup>.

**Current hydrogen technology**

Hydrogen can be produced from a variety of hydrocarbon feedstock including natural gas, LPG, naphtha and hydrocarbon-rich off-gases (obtained as purge or waste streams in refineries). The main process steps consist of:

- feed preparation to adjust the feed pressure and to remove catalyst poisons such as sulphur;
- preheating of feedstock and mixing with steam;
- conversion of hydrocarbon feedstock and steam to hydrogen and carbon monoxide;
- conversion of carbon monoxide and water to hydrogen and carbon dioxide;
- purification of hydrogen to typically more than 99.9 vol-%.

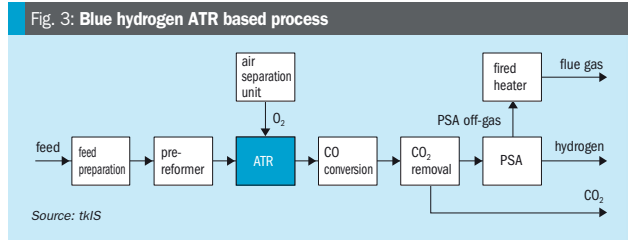
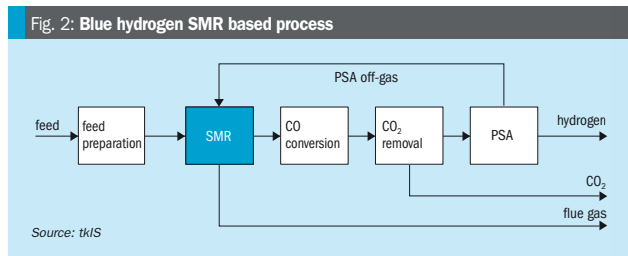

**Steam methane reforming**

The conventional process for producing industrial scale hydrogen is steam methane reforming. A block flow diagram for a blue hydrogen SMR based process is shown in Fig. 2.

SMR is a simple process that has been well-proven over decades. The feed preparation section typically consists of a desulphurisation and feed purification section. It is followed by the steam reforming section. For liquid feedstocks (naphtha or LPG), it is recommended to use a pre-reformer. For gaseous feedstocks (natural gas, refinery off-gases), the installation of a pre-reformer is not required. Downstream of the steam reforming section the water gas shift reaction takes place where CO and water are converted to hydrogen and carbon dioxide. Typically, carbon dioxide is removed by an absorption unit installed downstream of the CO conversion. To meet the final hydrogen specification a pressure swing adsorption unit (PSA) is installed for final purification. The PSA off-gas is entirely used in the steam reformer to supply the heat required for driving the endothermic steam reforming reaction. Steam reforming plants are very efficient since energy available in the product and the flue gas are recovered entirely. In a SMR process CO<sub>2</sub> is obtained from two sources:

- from the CO<sub>2</sub> removal unit as an almost pure CO<sub>2</sub> stream;

- from the combustion of PSA off-gas and make-up fuel and consequently as part of the flue gas.

The PSA off-gas contains residual methane and CO which are converted to CO<sub>2</sub> during combustion.

**Autothermal reforming**

For large-scale, single-train hydrogen production, autothermal reforming (ATR) can be applied. A typical flowsheet of an ATR process is shown in Fig. 3.

The feed preparation section is followed by a pre-reforming section which is mandatory for ensuring robust and reliable operation of the ATR. In the pre-reformer all higher hydrocarbons are converted into a mixture of hydrogen, methane, carbon dioxide and carbon monoxide. The methane content downstream of the pre-reformer is substantial. Part of the residual methane is oxidised in the ATR, while the balance is reformed to generate hydrogen and carbon monoxide. The partial combustion of methane requires pure oxygen which can be provided by an air separation unit ISBL or via pipeline over the fence. It is not recommended to use combustion air for partial oxidation since the increased nitrogen content in the hydrogen product would be too high. Residual carbon monoxide is converted together with water into hydrogen and carbon dioxide. Downstream of the shift conversion, carbon dioxide can

- from the combustion of PSA off-gas and make-up fuel and consequently as part of the flue gas.

be removed by absorption and the final purification of the hydrogen takes place in a PSA. The PSA off-gas can be used in a fired heater to provide heat for internal preheating and to generate superheated high-pressure steam. In the ATR process, the fired heater is required to provide sufficient preheating for the feed/steam mixture and to superheat steam which is required within the process.

The ATR process is of particular interest for large, single-train hydrogen capacities, since it can be operated at high pressure and consequently, at low volumetric flow. In addition, the CO<sub>2</sub> recovery is higher compared to a SMR process. This is attributable to the fact that the methane slip downstream of the ATR is much lower than downstream of an SMR. Hence, less methane is fired in the downstream fired heater than in the SMR itself, leading to lower CO<sub>2</sub> emissions. A post combustion CO<sub>2</sub> capture scenario is analysed below.

**Carbon dioxide removal**

In hydrogen plants, CO<sub>2</sub> is produced via the water gas shift reaction in the steam reformer and the shift conversion as well as during combustion of PSA off-gas and make-up fuel. After separation, CO<sub>2</sub> can be stored in long-term storage facilities, used in chemical synthesis (e.g. syngas, methanol, urea), as a feedstock for greenhouses or in the beverage industry. In a SMR or ATR process, CO<sub>2</sub> can be captured from:

- the process gas downstream of the shift conversion and upstream of the PSA (pre-combustion);
- from the PSA off-gas (pre-combustion);
- from the flue gas (post combustion).

Fig. 4 illustrates the three options for CO<sub>2</sub> removal for a typical SMR process. However, all of these options also apply to an ATR process scheme (see Fig. 5).

The separation of CO<sub>2</sub> from the process gas combines the advantages of high gas pressure and medium to high CO<sub>2</sub> concentration which facilitate the CO<sub>2</sub> absorption. It also combines low capex and low opex. Due to a great degree of heat integration, opex are low. The entire heat required for regeneration of the loaded solution is supplied by low caloric waste heat from the SMR/ATR process and basically comes at no cost. In contrast, it increases the overall efficiency of the plant.

The CO<sub>2</sub> from the PSA off-gas has the advantage of separating already concentrated CO<sub>2</sub> which is typically around

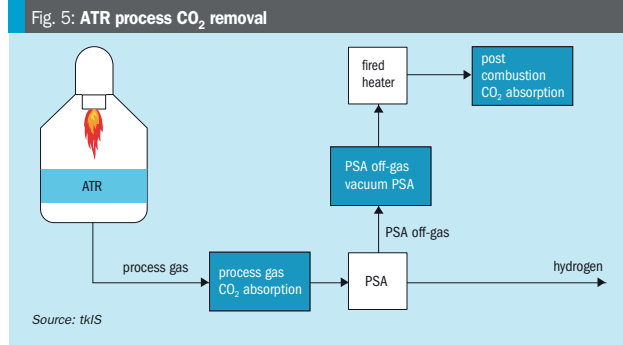
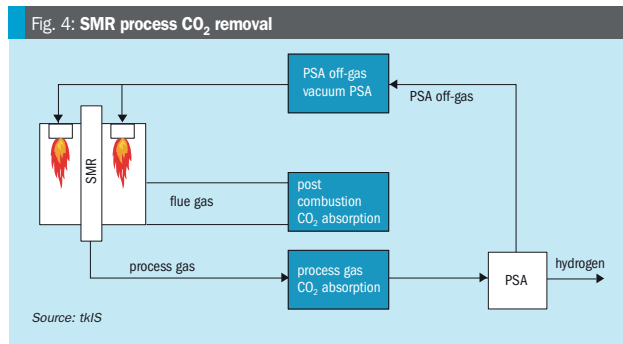

50 vol-%. Vacuum pressure swing adsorption can be used to separate CO<sub>2</sub> from the PSA off-gas. VPSA systems require mainly electrical energy and the potential for heat integration with the SMR/ATR plant is low. Hence, the additional electrical power cost translates into higher opex compared to absorption processes.

The separation of CO<sub>2</sub> from the flue gas achieves very high overall CO<sub>2</sub> recovery rates, since the CO<sub>2</sub> generated from the feed which remains in the PSA off-gas and from the fuel are captured at the same time. However, the volume flow rate of the gas to be treated is high, while the CO<sub>2</sub> concentration and the flue gas pressure are low, resulting in high capex.

**thyssenkrupp hydrogen technologies**

thyssenkrupp Industrial Solutions possesses all relevant technologies and experience to offer the entire spectrum of hydrogen production technologies, ranging from steam methane reforming and autothermal reforming to water electrolysis. In addition, tkIS

has developed and implemented revamp concepts for SMR based hydrogen plants in which CO<sub>2</sub> removal systems are installed as part of the revamp. tkIS has several operating references for blue hydrogen technology demonstrating the fact that blue hydrogen is a well-proven technology.

For revamping existing hydrogen manufacturing units, tkIS has developed a simple and robust concept to balance the heat in the SMR convection bank. The original design of the hydrogen plant considers a PSA off-gas with a substantial quantity of CO<sub>2</sub> in the PSA off-gas. Removing CO<sub>2</sub> from the process gas results in a CO<sub>2</sub> lean PSA off-gas. Consequently, it has a tremendous impact on the combustion in the SMR and the heat balance of the waste heat train (convection bank). Partial recycling of flue gas is the key to overcome limitations in heat duties while reducing NO<sub>x</sub> emissions at the same time. The entire system can be installed while the plant is in operation and the two tie-ins can be connected in short time during a schedule plant shutdown.

**CONTENTS**

What's in issue 371

**COVER FEATURE 1**

Waste gasification

**COVER FEATURE 2**

Nitrogen project listing

**COVER FEATURE 3**

'Blue' syngas technologies

**COVER FEATURE 4**

Improving ammonia plant economics

NITROGEN+SYNGAS  
**ISSUE 371**  
MAY-JUNE 2021

**BCInsight**

Southbank House, Black Prince Road  
London SE1 7SJ, England  
Tel: +44 (0)20 7793 2567  
Fax: +44 (0)20 7793 2577  
Web: www.bcinsight.com  
www.bcinsightsearch.com

Fig. 6: Topsoe SynCOR™ based blue hydrogen process scheme

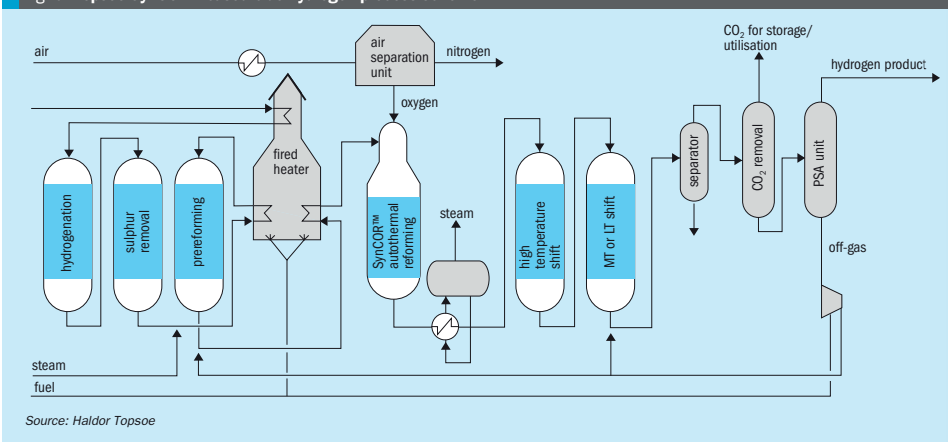

**Topsoe SynCOR™ based blue hydrogen process**

Topsoe offers well-proven steam methane reforming (SMR), combined with pre-combustion (high pressure) CO<sub>2</sub> capture and/or post combustion (low pressure) CO<sub>2</sub> capture technologies, for optimal blue hydrogen production with >90% CO<sub>2</sub> capture rate. For high capacity (>200,000 Nm<sup>3</sup>/h) blue hydrogen production, Topsoe offers its state-of-the-art SynCOR™ technology with pre-combustion (high pressure) CO<sub>2</sub> capture technology as shown in Fig. 6. It provides low emissions and cost-effective production of “blue” hydrogen with >95% CO<sub>2</sub> capture rate. These options can be either retrofitted to existing operating units or constructed as greenfield plants.

**Casale blue technologies**

Casale has developed efficient process schemes for blue ammonia and blue hydrogen production, based on technologies already available and referenced. Casale’s optimised process for blue ammonia production is able to compete in terms of opex and capex with processes without carbon sequestration.

**A6000CC: Casale process for blue NH<sub>3</sub>**

Adding a CO<sub>2</sub> recovery section to the flue gas from a primary reformer in a standard ammonia plant transforms it into a blue ammonia plant, with very high CO<sub>2</sub> sequestration (above 95%), but also adds significant capex and opex. In order to produce

blue ammonia without these penalties, in 2017, Casale started to develop a new process scheme, named A6000CC (named derived from the A6000 series of Casale processes, conceived for big capacities of up to 6,000 t/d or more). A6000CC is based on a pure oxygen-blown autothermal reformer (ATR) front-end, operated at high pressure (60 bar) with a low steam to carbon ratio of 1.5, preceded by a pre-reformer. This reforming scheme was selected to achieve high capacity, high efficiency and to reduce the generation of high temperature heat, which is the main source of carbon emissions to the stack.

The produced syngas is further processed in a shift section and purified in a CO<sub>2</sub> removal section and liquid nitrogen wash section to produce an inert-free make-up gas, which is compressed and sent to the synthesis loop to produce low-carbon cold ammonia. CO<sub>2</sub> is captured in the front-end, compressed and sent to battery limits.

**Process description and block flow diagram**  
A6000CC process has the following process sections, arranged as in Fig. 7:

- ASU;
- NG compression;
- desulphurisation;
- pre-reforming;
- O<sub>2</sub>-blown ATR reforming with a single-burner design and 3D printed tip;
- shift conversion (HTS + LTS);
- process condensate stripping;
- enhanced CO<sub>2</sub> removal based on amine wash (BASF Oase White);

- CO<sub>2</sub> compression to 200 barg;
- synthesis gas drying;
- liquid nitrogen wash purification with methane pre-condensation;
- ammonia synthesis loop and refrigeration;
- steam generation;
- steam turbine generator (STG);
- waste heat recovery (WHR) section.

Natural gas is mixed with a small stream of hydrogen, a stream of methane recovered from the liquid nitrogen wash (LNW) unit and the flash gas from the carbon dioxide recovery (CDR) unit. The feed is compressed to about 66 barg and pre-heated to about 380°C in a dedicated coil of the waste heat recovery section.

The gas stream is deeply hydrodesulphurised with a dedicated HDS catalyst bed and two H<sub>2</sub>S adsorption beds arranged in lead-lag to limit H<sub>2</sub>S slip to below 0.1 ppm.

Deeply desulphurised gas is mixed with HPS process steam with a S/C ratio of about 1.5 and pre-heated to about 520°C in a dedicated coil of the WHR section. The pre-heated mixed feed is pre-reformed with an outlet concentration of about 6% H<sub>2</sub> and with a substantial reforming of C<sub>2+</sub>, hydrocarbons and CO.

Pre-reformed gas is further pre-heated to about 650°C in a dedicated coil of the WHR section and delivered to the ATR. At the ATR burner, pre-heated pre-reformed gas at about 650°C is mixed with pre-heated oxygen at about 200°C with a suitable flowrate to achieve an outlet temperature of the ATR of about 1,000°C and

Fig. 7: A6000CC block flow diagram

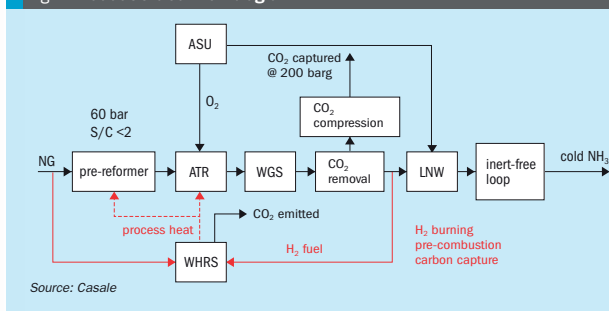

Table 1: Key performance indicators

Carbon dioxide production rate @200barg, tCO <sub>2</sub> /tNH <sub>3</sub>	1.51
Total natural gas consumption (LHV based) per t NH <sub>3</sub> *, Gcal/t NH <sub>3</sub>	7.2
Plant LHV thermal efficiency (natural gas to ammonia), %	62
Total CO <sub>2</sub> capture rate, %	90
Total CO <sub>2</sub> emissions to atmosphere, per t ammonia**, t CO <sub>2</sub> /t NH <sub>3</sub>	0.17
Carbon footprint of ammonia fuel product, based on LHV, kg CO <sub>2</sub> /MWh	32

\*Including utilities (CW, steam & power generation, CO<sub>2</sub> compression @ 200 barg), and without any credit for steam and power export nor any import of steam and power  
\*\*Considering flue gas emissions from the primary reformer + power station stacks

a methane slip of about 2.2% wet (EOR) after the reforming catalyst bed.

Downstream of the ATR the heat recovery train consists of waste heat boilers (WHB) and steam superheaters (SSH), with an intermediate temperature of about 550°C between the exchangers and an outlet temperature of about 380°C, which generates HPS steam at about 135 barg and is designed to mitigate the risk of metal dusting.

Reformed gas is delivered to the shift section comprising the HTS reactor and LTS reactor with enhanced heat recovery at high temperature.

Shifted gas is cooled down to about 64°C and process condensates are separated and pumped to the stripping section to remove by-products (methanol and ammonia) with HPS steam, producing a stripped condensate that is sent to the polishing unit. Shifted syngas is deeply purified in an enhanced CO<sub>2</sub> removal section based on amine wash (BASF Oase White) and in a liquid nitrogen wash purification section with methane pre-condensation, to deliver an inert-free make-up gas.

In the CDR section, shifted gas is deeply decarbonised to a residual CO<sub>2</sub>

content of less than 5 ppm. Captured CO<sub>2</sub> is compressed to 200 barg in a six-stage integrally geared compressor, with a DEOXO catalyst guard and a drying unit on the discharge of the third stage, to deliver CO<sub>2</sub> at the requested purity level. The CDR section also produces a flash gas that is recycled back as feed gas.

In the LNWS unit, methane is pre-condensed at about -183°C and recycled back as feed gas. The CO<sub>2</sub>-depleted synthesis gas is further purified in the cryogenic wash column with liquid nitrogen flow. At the outlet of the cryogenic box three streams are separated: the purified inert-free make-up gas, a fuel gas used for heat and power generation and the methane-rich stream recycled as feed gas at the NG compressor suction (leading to about +1% CO<sub>2</sub> capture rate contribution).

The H<sub>2</sub>/N ratio of the purified inert-free make-up gas is adjusted with additional nitrogen compressed at about 53 barg and delivered to the suction of the syngas compressor. Make-up gas and recycle gas are compressed to about 170 barg and delivered to the ammonia converter(s) loaded with Amomax-Casale catalyst. The heat recovery includes BFW pre-heating and boilers to generate HPS.

Key performance indicators for Casale blue ammonia are provided in Table 1.

The A6000CC process scheme can be applied to an existing plant through revamping, by modifying the reforming route to ATR. The front-end section downstream of the reforming and synthesis loop can be retained, and ammonia production capacity can be increased, improving the economics of the project. The energy efficiency has to be evaluated case by case.

**H1000CC: Casale process for blue hydrogen**

The A6000CC scheme can be easily modified to produce blue hydrogen instead of blue ammonia by eliminating the synthesis loop and liquid nitrogen wash sections.

H1000CC is a patented Casale process scheme based on a pure O<sub>2</sub>-blown ATR front-end, operated at high pressure (generally 60 bar) with a low S/C (about 2.0), preceded by a pre-reformer.

The produced syngas is further processed in a shift section and purified in a CO<sub>2</sub> removal section to produce a blue hydrogen product. CO<sub>2</sub> is captured in the front-end, compressed and sent to battery limits. Installation of a pre-reformer permits reforming at a low steam to carbon ratio, which has significant debottlenecking effects on the whole section. The relatively small heating duty and overall plant efficiency are key factors to achieve a substantial reduction of the CO<sub>2</sub> stack emissions compared to a conventional process.

**Process description**

The main units of the new Casale hydrogen plant are shown in the block flow diagram in Fig. 8.

The main process sections are:

- ASU;
- NG compression;
- desulphurisation;
- pre-reforming;
- O<sub>2</sub>-blown ATR reforming with single-burner design and 3D printed tip;
- shift conversion (HTS + LTS);
- process condensate stripping;
- enhanced CO<sub>2</sub> removal based on amine wash (BASF Oase White);
- H<sub>2</sub> purification unit (optional, according to the specification);
- CO<sub>2</sub> compression to 200 barg;
- steam generation;
- steam turbine generator (STG);
- waste heat recovery section (syngas burning).

Key performance indicators for Casale blue hydrogen are provided in Table 2.

**Key features of Casale design**

The A6000CC and H1000CC processes offer the following process advantages:

- easy scalability (no tubular reformers) to high single-train capacities, lowering capital and operating costs, and improving the plant's operability and reliability, whatever the feedstock;
- minimisation of fired duty for process purpose as flow is minimised (low S/C ratio);
- high total carbon capture with one single CDR in the process (no CDR on flue gas);
- for H1000CC, the possibility to deliver H<sub>2</sub> product up to 55 bar.

For high production capacities, the benefit of having one single line instead of multiple lines are:

- lower total investment cost;
- less plot space,
- fewer operators.

Plant reliability is one of the main factors for hydrogen plant profitability. Achieving plant targets strongly depends on having a reliable design that is flexible, efficient and economical.

According to Casale strategy, safety is one of the major plant design targets and a reliable design is the most crucial factor that makes it possible to achieve this goal.

Safety in the design of petrochemical process plants primarily relies on the application of various codes of practice or design, which are based on the wide experience and knowledge of professional experts and specialists in the industry. That is backed up by the experience of local plant managers, engineers and operators, who have direct experience in the relevant plant operation.

**Casale ATR**

Casale ATR is a key technology in both A6000CC and H1000CC processes. In autothermal reforming a catalytic bed is installed within a refractory-lined pressure vessel to bring the methane steam reforming reaction as close to equilibrium as possible.

The Casale autothermal reformer (ATR) design is conceptually very simple. The oxygen stream is introduced at high velocity axially at top of the combustion cylindrical chamber. The partially reformed gas is

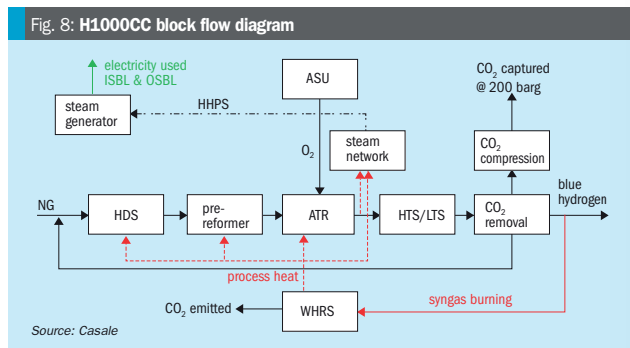

Table 2: Key performance indicators

Gross natural gas consumption, MJ/Nm <sup>3</sup> H <sub>2</sub>	15.5-16.0*
Energy conversion efficiency heating value of hydrogen product stream / heating value of received feed gas stream, MW/MW	0.7
CO <sub>2</sub> removal efficiency molar flow of CO <sub>2</sub> to CO <sub>2</sub> sequestration unit / molar flow of carbon atoms in the feed gas to the unit, mol <sub>CO2</sub> / mol <sub>CO2</sub>	> 0.9
Carbon intensity of produced hydrogen kg CO rejected to atmosphere / kg H <sub>2</sub> product stream, kg <sub>CO2</sub> /kg <sub>H2</sub>	< 0.2

\*This figure, as well as all others in the table, includes CO<sub>2</sub> compression up to 200 bar. Without CO<sub>2</sub> compression and considering an equivalent of 8.372 MJ/kWh, gross natural gas consumption is reduced by 0.7 MJ/Nm<sup>3</sup>H<sub>2</sub>

introduced from one side at the top of the cylindrical chamber, before the burner tip, perpendicular to the burner. The high velocity of the oxygen causes mixing between the two streams and the combustion reaction takes place instantaneously after mixing. A circular distributor with a small pressure drop is provided upstream the burner in order to obtain a uniform flow of natural gas before its mixing with the oxygen.

In order to maximise the distance between the burner tip and the catalytic surface the vessel neck is used as a refractory-lined combustion chamber. The combustion chamber length is chosen in order to avoid impingement of the burner flame over the reforming catalyst while achieving an almost uniform distribution of temperature and gas composition at the chamber outlet before the vessel cone. The impingement of the flame on the catalytic bed would damage its superficial layer generating performance losses (higher methane slip) and increased pressure drop.

The fluid-dynamic flow field inside the combustion chamber is designed in order to protect the refractory lining from the

high temperature core of the flame, preventing hot spot on the lining surface.

The gas recirculation that builds up inside the combustion chamber shield the refractory lining from the flame hot core, which can reach temperature as high as 2,700°C, keeping its surfaces well under 1,400°C, i.e. well below the refractory maximum operating temperature.

Due to the high temperature reached by oxygen-hydrogen and oxygen-hydrocarbon combustion the burner tip is provided with a forced convection cooling water system.

The water path inside the burner tip ensures uniform cooling of all the burner walls. In particular, the heat transfer coefficient of the water flow has been enhanced corresponding to the tip that is close to the flame.

Fig. 9 shows the Casale single-burner and multi-burner ATR design.

Casale uses CFD tools when designing its burners to simulate the flow and temperature fields inside the combustion chamber and within the burner body, taking into account the strong correlation between turbulence and chemical kinetics. The CFD results are used together with thermal and FEM analysis of the burner's solid surfaces, which are

essential to understand and optimise the burner design. These calculations are confirmed by industrial experience. Casale's approach addresses most of the common problems relating to reformer burners: poor mixing, soot formation and overheating of the surfaces exposed to the flame.

The main features of Casale's pure oxygen autothermal reformer burner design are:

- Good mixing between oxygen and natural gas, with an almost uniform field of temperature, velocities and composition at the catalytic bed entrance:
  - a better equilibrium approach due to almost uniform temperature and composition at the catalytic bed inlet.
  - a shorter flame; avoiding the impingement of the flame on the catalytic bed, thus resulting in longer life of the catalyst, better performance and no pressure drop increases due to sintering/milling.
- Soot-free operation
- Flexible operation, allowing good burner performance over a wide range of flow rates.
- Low temperature of the reformer refractory lining.
- Water-cooled burner tip in order to ensure several years of safe operating life with low temperature of the burner surfaces exposed to the flame:
  - no plant shutdown related to burner failure
  - proven trouble-free operation
  - up to eight years of proven operation with a single Casale burner
- Flame stability.

- proven trouble-free operation
- up to eight years of proven operation with a single Casale burner
- Flame stability.

Soot formation has been studied in depth by Casale thanks to a vast amount of information gained from a long series of experiments conducted on a demonstration size pilot burner in recent years. Thanks to this unique experience, Casale can predict with absolute confidence what operating conditions may lead to soot formation and indicate how to operate to avoid it.

**Operating experience**

Casale has experience in the design of ATR reactors for both ammonia and methanol production and for both two-step reforming and pure ATR (with coke oven gas) configurations. Casale has several referenced ATR reactors for methanol production in operation or scheduled for start-up, with capacities ranging from 350 to 7000 t/d. At present there are nine units in operation, including a 5,000 and a 7,000 t/d methanol plant.

The first Casale ATR application was for a 350 t/d methanol plant with two-step reforming. This unit has been operating continuously since its start-up in October 2001.

The burner was operated over a wide range of flow rates, from 20% to 110% of the design load, without performance losses or any other operational problems.

Fig. 9: Casale single-burner and multi-burner ATR design

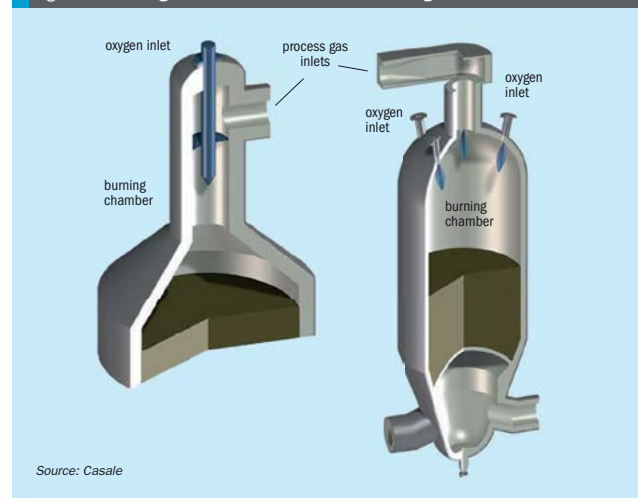

CONTENTS

What's in issue 371

COVER FEATURE 1

Waste gasification

COVER FEATURE 2

Nitrogen project listing

COVER FEATURE 3

'Blue' syngas technologies

COVER FEATURE 4

Improving ammonia plant economics

NITROGEN+SYNGAS  
ISSUE 371  
MAY-JUNE 2021

BCInsight

Southbank House, Black Prince Road  
London SE1 7SJ, England  
Tel: +44 (0)20 7793 2567  
Fax: +44 (0)20 7793 2577  
Web: www.bcinsight.com  
www.bcinsightsearch.com



Fig. 6: Capital cost for absorbers with tray design and structured packing

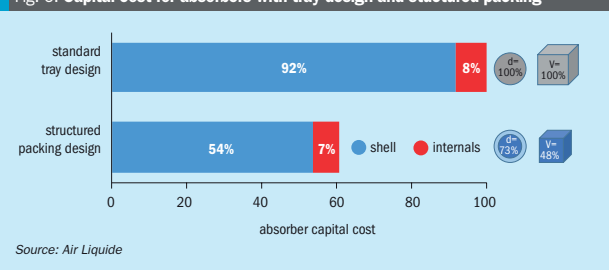

ated by the RDU. The gas capacity ranged from 180 kNm<sup>3</sup>/h-900 kNm<sup>3</sup>/h, pressure ranged from 35-55 bara and CO<sub>2</sub> content in the feed gas ranged from 25-35 mol-%. For a fair comparison, both designs have been conducted using widely commercially available mass transfer internals.

Fig. 5 shows a normalised absorber diameter against the feed gas capacity for trayed and structured packing design. Most importantly, the diameter reduction by using a structured packing design compared to a tray design is around 25%.

Additionally, Fig. 6 indicates the typical downstream applications of a Rectisol™ unit for the respective gas capacities, such as hydrogen production (for blue hydrogen with carbon capture and storage, ammonia production, power block or refinery applications), methanol synthesis, Fischer-Tropsch fuels, waste-to-fuel/biomass-to-fuel applications or synthetic natural gas (SNG).

### Results: optimisation of the Rectisol™ unit (opex & capex)

To investigate the overall savings in opex and capex, a Rectisol™ unit with a gas capacity of 200 kNm<sup>3</sup>/h was simulated assuming structured packings as mass transfer internals for the absorber and reabsorber. In comparison to using trays in these columns, the structured packing design has the advantage of reduced pressure drop, higher separation efficiency (lower HETP) and the aforementioned higher liquid loads. The increased separation efficiency leads to reduced liquid flows requiring smaller equipment as well as decreased pump duties and steam consumption for solvent recovery. At the same time, the smaller pressure drops enable the operation of the regeneration part at lower pressures which leads to higher cold recovery and less refrigeration consumption.

As a reference, this setup was compared to an industrial as-built plant with tray design for both the absorber and reabsorber. The opex was evaluated using utility costs for a Chinese location. The capex were also evaluated on a high level basis.

The outcome for the absorber with dedicated sections for CO<sub>2</sub>, H<sub>2</sub>S and COS and trace component removal is summarised in Fig. 6.

The diameter of the structured packing absorber is 73% compared to the trayed absorber column (100%). At the same time, the volume of the column is decreased. It should be noted that the height of the column is also slightly decreased as a result of the reduced height required for structured packing and also because of the slightly reduced solvent flows leading to less height being required for the liquid levels in the column.

Fig. 6 also shows the capital cost savings if a structured packing design for an absorber is used instead of a conventional tray design. The absorber capital cost for the structured packing design is given as a fractional cost of the trayed design. It can be observed that the cost for the internals are almost the same for both options (8% vs. 7%). However, the cost for the high-pressure service shell reduces drastically for the absorber with the smaller diameter. In total, compared to the trayed design absorber, the capital costs for the structured packing absorber is 61%.

In terms of opex reduction, the application of structured packings in the reabsorber leads to reduced pressure drop and higher separation efficiency. The lower pressure drop is beneficial for the operation of the solvent regeneration, as it allows it to operate under lower pressure and leads to higher cold recovery by flashing of CO<sub>2</sub> and less steam consumption for solvent

recovery. Additionally, less electricity is required for pumps due to the lower operating pressures in the regeneration section. All in all, the application of structured packings within the Rectisol™ unit results in 17% opex savings, including savings for refrigeration duty of 19%, electricity 16% and steam of 18% compared to the case with the tray design. Taking account of the indirect CO<sub>2</sub> emissions arising from steam and electricity, 16% less CO<sub>2</sub> is emitted.

Due to the reduced solvent flow rates and the smaller absorber, the size of other equipment is also reduced, resulting in an overall capex reduction on the Rectisol™ equipment of 7%.

Air Liquide Engineering & Construction is able to tailor Rectisol™ column design to the needs of its clients. It should be noted that the benefits as evaluated and presented above can be obtained by implementation of state-of-the-art, widely available structured packing as mass transfer internals. Air Liquide Engineering & Construction is also able to apply sophisticated high capacity internals which will give an even more competitive design.

### Summary

With their Rectisol™ demonstration unit, Air Liquide Engineering & Construction has unique know-how in Rectisol™ column design with structured packings. The application of commercially available structured packings in the absorber column leads to a capital expenditure reduction of 39%, following an absorber diameter reduction of 27%. Further application of structured packing within the reabsorber column results in operational expenditure savings of 17% due to the decreased operating pressure of the regeneration system. Owing to the reduced solvent flow rates and the decreased equipment sizes, a total capital expenditure reduction of 7% for the whole Rectisol™ unit equipment is accomplished.

### References

1. Air Liquide Engineering & Construction Technology Handbook, November 2020: [https://www.engineering-airliquide.com/sites/activity\\_eandc/files/2020/11/03/technohandbooknov2020.pdf](https://www.engineering-airliquide.com/sites/activity_eandc/files/2020/11/03/technohandbooknov2020.pdf)
2. Masurel et al., "Chemical engineering transactions"
3. Lockett, Distillation tray fundamentals, 1986
4. Sulzer Sulcol 3.0.8

## Working towards a decarbonized industry with innovative technologies

Air Liquide's state-of-the-art technologies are helping customers worldwide to reduce their carbon footprint.

Cryocap™: a complete suite of innovative proprietary technologies, unique in the world, for the capture and management of CO<sub>2</sub> combining cryogenic, adsorption and membrane technologies:

- Cryocap™ H<sub>2</sub> for Hydrogen plants
- Cryocap™ FG for Flue Gas
- Cryocap™ Oxy for Oxycombustion
- Cryocap™ XLL for CO<sub>2</sub> Liquefaction
- Recticap™ downstream Auto-Thermal Reforming



Air Liquide's highly efficient and robust technology, Cryocap™, operating at large scale for more than 5 years in Port Jerome, France, enables the capture of CO<sub>2</sub> from a hydrogen production unit via a combination of cryogenic and membrane processes.

[cryocap@airliquide.com](mailto:cryocap@airliquide.com)  
[engineering-airliquide.com](http://engineering-airliquide.com)

# The green and safe way to produce ammonium nitrate

In August 2020 the tragic explosion of ammonium nitrate fertilizer in the port of Beirut caused many fatalities and injuries. This was a wake-up call for the entire industry to review the design of plants and storage facilities, as well as the procedures for plant operation and the handling of products. The key factor for safe new installations is the process design: the right choice of unit operations, operating temperatures and pressures, the control of process variables and the design of key items of equipment. A modern ammonium nitrate (AN) plant design not only mitigates the environmental impact, but also reduces investment costs and contributes to the key factors mentioned. **M. Pieper** and **P. Kamermann** of thyssenkrupp Industrial Solutions discuss how, by using the right design, safety in ammonium nitrate plants can be easily achieved, while maintaining outstanding product quality.

Many of us will recall the pictures and video records showing the effects of the tragic Beirut explosion on August 4, 2020. Investigations proved that the disaster was caused by 2,750 tonnes of ammonium nitrate (HDAN) – stored together with fireworks – brought to rapid decomposition (explosion) by an external fire. However, as with most incidents, a series of failures finally led to the catastrophe. In the Beirut case, this can be attributed to a lack of knowledge about

the specific properties and risks caused by the misuse of AN.

AN is considered to be safe, but can decompose or even explode when not treated correctly. Care has to be taken to avoid extensive heat input and contamination, the main triggers for decomposition<sup>1</sup>. Therefore, any source of heat and burnable substances must be kept away from AN storage facilities. In addition, the maximum storage capacity should be limited – several stacks of bagged AN rather

than one large heap. None of this is new to those active in the AN business and it can be found in various sources of literature, e.g. from Fertilizers Europe<sup>2</sup> and IFA. In Beirut, the guidelines were clearly not observed by the parties involved. Presumably, they were inexperienced in the handling of AN.

As a general rule of thumb, AN is safe when a) not exposed to heat and b) not contaminated by foreign (organic) materials.

Fig. 1: Ammonia volatilisation of different fertilizers

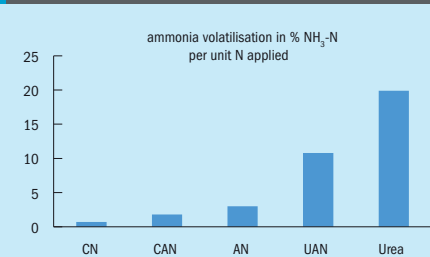

Source: EMEP/EEA Emission Inventory Guidebook 2013

Fig. 2: Yield and protein content for different fertilizers

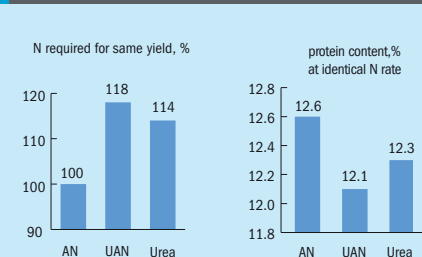

Source: DEFRA, UK

Fig. 3: Simplified flowsheet of uhde® vacuum neutralisation

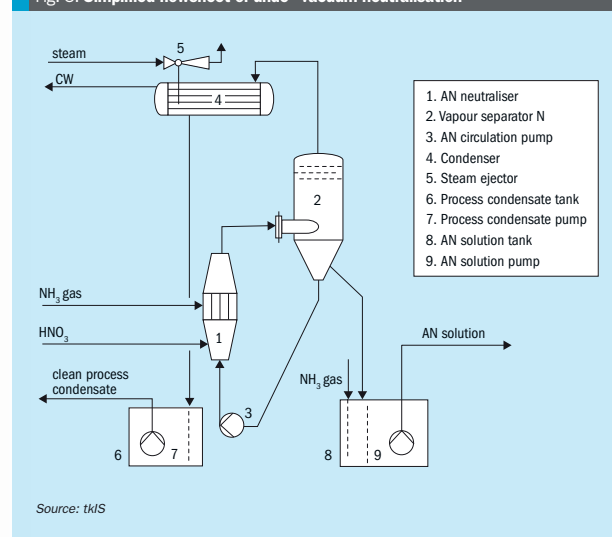

Source: thS

Producers cannot entirely avoid incidents from happening, but they must do their utmost to ensure safe production and on-site storage of AN. In West, Texas, in 2013 another accident reminded the community of AN producers that failures occur even with those working with AN on an everyday basis.

## AN as a fertilizer

But why is AN used as a fertilizer in the first place when there is a risk of incidents with fatalities, and what advantages does it have over other fertilizers?

First of all, worldwide ammonium nitrate is the second most important nitrogen fertilizer after urea. In addition, AN has the advantage of containing two different forms of nitrogen: nitrate (NO<sub>3</sub>) that can be taken up by plants directly and rapidly and ammonium (NH<sub>4</sub><sup>+</sup>) that has to be converted by bacteria in the soil first. As a result, nitrogen is available to the plants directly and over an extended period of time, not just once or over the long term. Another important issue is the higher yield in both nitrogen availability and crops when applying AN (compared to UAN or urea): The loss of nitrogen (by ammonia volatilisation) contributes to pollution, affects the air quality and simply wastes resources. Fig. 1 shows that ammonia volatilisation is

several times lower for AN-based fertilizers like AN or CAN compared to urea or UAN. Quantity (crop yield) and quality (protein yield) are also higher with AN compared to urea (Fig. 2).

## Green technologies

By utilising renewable energy sources to produce green hydrogen/syngas/ammonia/nitric acid and finally green AN, a complete and integrated environmentally-friendly fertilizer production line can be designed by thyssenkrupp Industrial Solutions (thyssenkrupp Uhde as of June 1, 2021), based on its own technologies:

- hydrogen generation by water-electrolysis;
- conversion to ammonia<sup>3</sup>;
- nitric acid production with highest (beyond BAT) N<sub>2</sub>O-reduction technology EnviNO<sup>x</sup>®<sup>3</sup>;
- ammonium nitrate production with the option to feed granulation-, prilling- or UAN-plants.

## Plant safety by design

It is still reasonable for AN to be used widely as a fertilizer – but what can manufacturers do within their own scope of responsibility to strictly minimise the likelihood of an accident? What is mandatory for the safe production of AN?

## Basic rules

There are some basic rules to be considered for the design and operation of AN plants:

**Temperature and pressure:** Depending on the temperature, AN starts to decompose by following several chemical reactions, which lead to various chemicals and compositions. Reactions that start at elevated temperatures (>180°C) are problematic as they generate huge amounts of heat and are therefore self-sustaining. The released gaseous reaction products can cause enclosures to burst or even explode when confined. If the first gases are not vented but accumulate in the system, the increasing pressure accelerates the decomposition processes even further.

This chemical response to physical influences requires the following design rules:

- low operating pressure;
- release of gases/vapours must be possible at any time;
- low temperatures must be maintained;
- any possibility of heat input into the system must be observed and limited.

**Composition:** Even though AN is formed by neutralising nitric acid with ammonia in equal molar ratio, its composition is very important when it comes to safety. There are several ions with a negative effect on the onset-temperature of AN's decomposition reactions: With increasing concentration of impurities like chlorides, (organic) carbon, metal ions (Cu, Zn, Cr,...) and the like, the onset-temperature decreases – reactions are more likely to happen and will develop more quickly. Carbon, in particular, when reacting with AN, will liberate large amounts of heat. But, not only foreign ions, even nitric acid itself can promote the described effects if applied in excess or having become available due to decomposition reactions. Such a reaction already takes place at ambient temperature: AN slowly decomposes into nitric acid (causing the pH value of the aqueous solution to drop) and gaseous ammonia, leaving the system via the vent. AN producers will all be familiar with the faint smell of ammonia in close proximity to AN storage vessels that are not properly vented.

As a result, the plant design has to meet the following challenges: precise feedstock control, process monitoring and provisions to compensate for the natural acidifying of AN solutions accompanied by strict quality management of the feedstock.

What's in issue 371

COVER FEATURE 1

Waste gasification

COVER FEATURE 2

Nitrogen project listing

COVER FEATURE 3

'Blue' syngas technologies

COVER FEATURE 4

Improving ammonia plant economics

NITROGEN+SYNGAS  
ISSUE 371  
MAY-JUNE 2021

BCInsight

Southbank House, Black Prince Road  
London SE1 7SJ, England

Tel: +44 (0)20 7793 2567

Fax: +44 (0)20 7793 2577

Web: www.bcinsight.com  
www.bcinsightsearch.com

Fig. 4: In-situ sample preparation for pH measurement for uhde® vacuum neutralisation and concentration

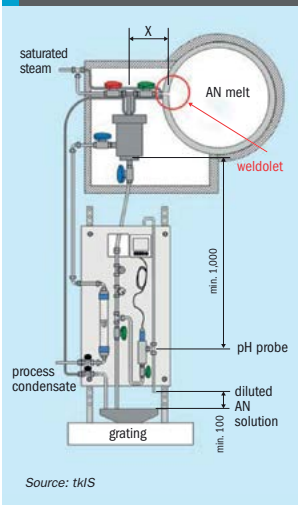

Source: tkIS

Fig. 5: Simulation of flow velocity and distribution of reactants in an uhde® reactor

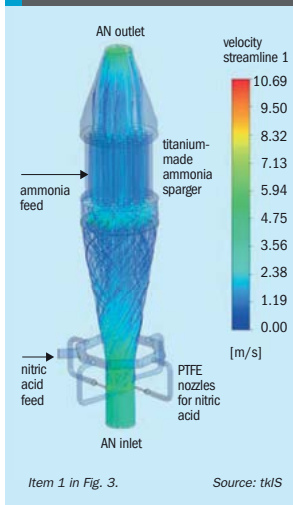

Item 1 in Fig. 3.

Source: tkIS

of only 145°C, thereby staying away from critical on-set limits (see Fig. 3). Additionally, the precise control of both pressure and temperature enables AN producers to generate AN solution at a constant concentration of e.g. 92 wt-% in the neutralisation step (item 1, Fig. 3). This high grade AN is achieved without external steam supply just by flash evaporation – the resulting vapours are thoroughly clean as well as condensed, leaving no chance for any nitrogen to pass into the atmosphere (item 4, Fig. 3). Besides the high nitrogen yield, no increase in system pressure is possible. An ESD system continuously monitors the temperature, pressure and critical flows, while a sophisticated control system takes care of the best operating conditions: An uhde® AN vacuum neutralisation system not only runs at low temperatures, but also at slightly acidic conditions. This is the key factor for the safe control of process parameters and lowest nitrogen slipage through process vapours. The proper pH value for (intermediate) storage is in the alkaline range and is adjusted downstream of the vapour separation under atmospheric conditions (item 8, Fig. 3).

Fig. 6: combined uhde® neutralisation and concentration (simplified scheme)

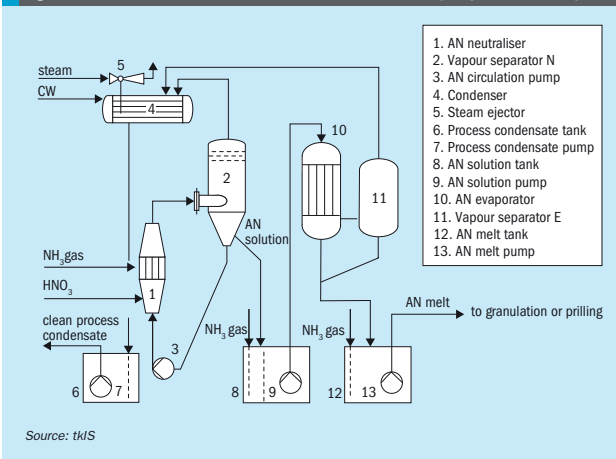

Source: tkIS

**Basic process**

How can these limiting safety considerations be combined in an AN neutralisation plant?

In general, the focus of the plant design is on safety. Nonetheless, other important aspects of plant operation are also looked at, e.g. flexibility in plant load, export of

very pure process condensate and general ease of operation (i.e. no wear and tear parts in static equipment).

Choosing to operate an uhde® AN vacuum neutralisation and concentration unit, allows plant operators to perform the exothermic reaction between nitric acid and ammonia at a low temperature

**Special features**

An important contributor to safety and homogenous product quality (see uhde® pH measuring system, Fig. 4) is the measurement of pH values throughout systems containing AN solution by a proven sampling system. The lifetime of the pH probe is prolonged by diluting the AN solution with water and thereby reducing the risk of crystallisation. The feed of saturated steam through the red coloured valve (see Fig. 4) is normally closed, but can be used for flushing purposes.

Furthermore, in cases of a prolonged period of time running on lower pH levels than optimal for process control, the plant is stopped automatically by its control system. Even during a shutdown, the plant does not need to be drained. After stopping the feedstocks, the circulation pump will still be in operation allowing for a very quick restart.

Inside the reactor, the key to reducing ammonia losses (environment) and minimising spots of high nitric acid concentration (safety) is to have the ideal mix of the reactants ammonia and nitric acid. The result of a FLUENT® simulation in Fig. 5 demonstrates the almost perfect flow pattern in the uhde® reactor.

Not only the neutralisation reaction, but even the concentration to the final



SAFETY IN AMMONIA PLANTS & RELATED FACILITIES SYMPOSIUM

**ATTEND THE 65<sup>TH</sup> ANNUAL SAFETY IN AMMONIA PLANTS & RELATED FACILITIES SYMPOSIUM**

August 29 - September 2, 2021 • Manchester Grand Hyatt, San Diego, CA

A century of ammonia synthesis technology with an emphasis on continual progress in ammonia plant safety.

**6 REASONS TO JOIN US IN 2021**

- ✓ Collaborate with over 400 industry attendees from more than 40 countries
- ✓ Learn from others how to promote safety, operability, and reliability at your company
- ✓ Attend high quality technical presentations covering a range of safety and reliability topics
- ✓ Hear a roundtable discussion about industry incidents and near misses
- ✓ Receive an overview of what products are available to improve safety performance
- ✓ Meet vendors, service providers, and exhibitors, offering access to the latest technical innovations

SAVE WHEN YOU REGISTER BY JULY 22

Register and learn more about #Ammonia2021 at [aiche.org/ammonia](https://aiche.org/ammonia)

Symposium attendees will learn the latest safety developments, safety incident studies, technological advancements, and maintenance improvements. You are invited to be part of the program.

For general information about the Ammonia Symposium, please contact Ilia F. Killeen at 646-495-1316 or [iliak@aiche.org](mailto:iliak@aiche.org).

ORGANIZED BY **AICHE**  
The Global Home of Chemical Engineers

CONTENTS

What's in issue 371

COVER FEATURE 1

Waste gasification

COVER FEATURE 2

Nitrogen project listing

COVER FEATURE 3

'Blue' syngas technologies

COVER FEATURE 4

Improving ammonia plant economics

NITROGEN+SYNGAS  
**ISSUE 371**  
MAY-JUNE 2021

**BCInsight**

Southbank House, Black Prince Road  
London SE1 7SJ, England  
Tel: +44 (0)20 7793 2567  
Fax: +44 (0)20 7793 2577  
Web: [www.bcinsight.com](http://www.bcinsight.com)  
[www.bcinsightsearch.com](http://www.bcinsightsearch.com)



Fig. 7: uhde® AN pressure neutralisation and concentration (simplified scheme)

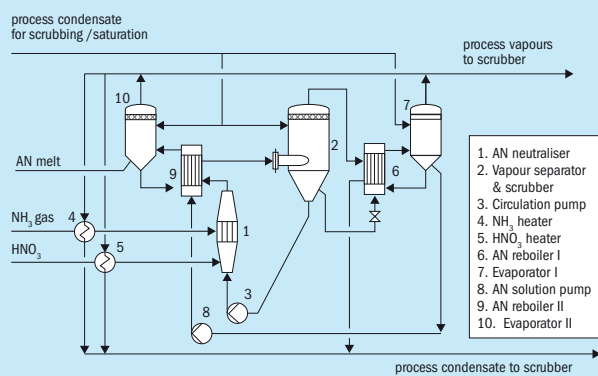
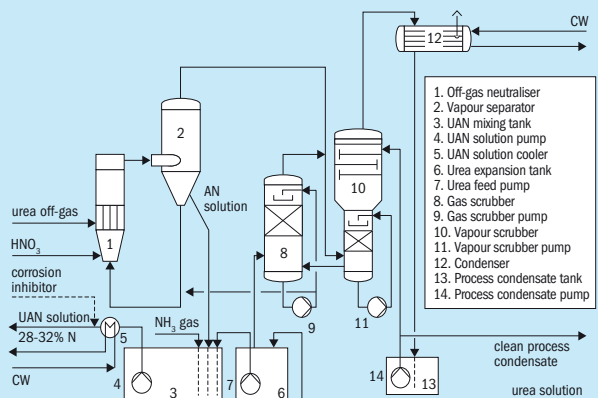

Fig. 8: uhde® urea off-gas neutralisation (simplified scheme)



AN melt can be performed under sub-atmospheric pressure, relieving the plant management from having to think about operating temperatures beyond the on-set temperature and resulting formation of AN aerosols in the separated vapour stream and their abatement. The comparably low temperatures and the absence of air-swept concentrators avoids the formation of AN aerosols right from the very beginning. uhde® AN vacuum neutralisation and concentration plants are free of aerosols

and have clean vents – only leakage air from the vacuum systems containing inert gas is released to atmosphere.

**Latest Developments**

The latest development in tkIS AN technology is the combination of the two vacuum units (neutralisation and concentration) to form one common vapour and condensate system as shown in Fig. 6, items 4 to 7 (patent pending). With AN melt being the final product, the concentration and tem-

perature of this fluid defines the system pressure in the entire vacuum network. The vapours from concentration and neutralisation are cleaned separately, under their respective ideal conditions, but merged afterwards and finally condensed together. In doing so, there is no longer a need for a dedicated condenser for the concentration unit and both systems have one common process condensate tank.

Other variants of neutralisation plants include systems operating at atmospheric pressure (in the vapour separator) or even at elevated pressure, depending on project-specific requirements like availability and cost of utilities. When designing those plants, special attention must be paid to the operating temperatures in the AN system, to absolutely avoid reaching the onset conditions of decomposition reactions. A wise selection of construction materials for pressure neutralisation plants is mandatory as the corrosion rate increases with elevated temperatures. Fig. 7 shows an example where process waste heat is used in reboiler 6 and 9.

Due to the chosen operating pressures and temperatures and the utilisation of process heat for concentrating the AN solution, pressure neutralisation is the right choice. In particular, if the focus is on safety and, additionally, on utility consumption (steam and cooling water) rather than investment cost.

With UAN production it might be commercially beneficial to feed the low-pressure, ammonia-rich off-gas of a urea plant directly to the AN neutraliser. Consequently, the system pressure in the AN neutralisation must be lowered to cope with the pressure of the urea off-gas. This can be achieved by natural draft circulation instead of the forced circulation that is typical for most plants (see Fig. 8). Thereby low pressure off-gases from a urea synthesis unit can be utilised to produce AN that meets environmental limits by using dedicated additional scrubbers (items 8 and 10 in Fig. 8).

**Reliability**

What is the key to building safe AN solution plants with almost all-year round operation?

The application of nitric acid nozzles made of PTFE (see Fig. 8) ensures year-long operation of the AN neutralising reactor without any maintenance being necessary. Gaseous ammonia is brought into contact with the circulating, acidified AN solution by means of a titanium-made

sprayer (see Fig. 8), which lasts the whole lifetime of the plant. Even after an unplanned shutdown, e.g. due to power failure, the plant can usually be restarted within 30 minutes. All AN inventory is stored in either the neutralisation loop or the intermediate buffer tanks, allowing for close condition monitoring and precise control of the temperature, concentration and pH value. Gaseous ammonia and water can be added at any time to all AN-containing systems, due to the fact that AN is safe if treated properly! Further aspects like the monitoring of pumps (possible sources of heat into the AN solution), utilisation of saturated steam, avoidance of “dead legs” in the piping system, and sophisticated and reliable interlocking systems are part of a state-of-the-art AN neutralisation plant. If the internal values are not of main interest, then the measurable external results are: The typical nitrogen content in the process condensate leaving this type of neutralisation plant is below 10 ppm. From a technical point of view this is a unique contribution to the environment as no further dedicated water treatment section needs to be involved.

**Customer orientation**

How can safety requirements, internal and external standards and client requirements in the design phase be handled by assuring quality while not following the ‘copy and paste’ approach?

The design of safe, reliable and individual plants must consider lessons learned, strict internal and external standards based on experience and best practice, while at the same time focussing on the client’s needs. This can be achieved by using the Pre-Configured Plant Concept, PCPC, approach. This engineering method divides up a complete plant into functional modules, covering all main engineering documents for the design of a standardised plant and summarising all safety and operability related information to represent a holistic and quality assured basis for proposals. The PCPC method includes key information from all engineering disciplines like process, layout, piping, static equipment and machinery. The system is stringent in so far as it ensures quality and safety, but it is also flexible in that it allows tailor-made proposals according to client’s requirements.

**Conclusion**

Even though AN is a potentially hazardous substance that requires advanced attention, it is a state-of-the-art fertilizer and can as such contribute to the global effort to reduce greenhouse gas emissions. When AN is produced under well selected conditions at a plant that was designed with experience and care, significant steps towards a safe product have been taken.

**References**

1. Babrauskas V.: “Ammonium nitrate: Tragic lessons still to be learned”, <https://www.fireengineering.com/2020/08/27/492725/ammonium-nitrate-tragic-lessons-still-to-be-learned/>
2. Fertilizers Europe, Guidance for the storage, handling and transportation of solid mineral fertilizers, accessible via: <https://www.fertilizereurope.com/publications/guidance-for-the-storage-handling-and-transportation-of-solid-mineral-fertilizers/>, [www.productstewardship.eu/fileadmin/user\\_upload/user\\_upload\\_prodstew/documents/Storage\\_handling\\_and\\_transportation\\_of\\_solid\\_mineral\\_fertilizers.pdf](http://www.productstewardship.eu/fileadmin/user_upload/user_upload_prodstew/documents/Storage_handling_and_transportation_of_solid_mineral_fertilizers.pdf)
3. Birwe T. et al.: “Green chemicals: new routes in ammonia and methanol production”, Fertilizer Focus (Jan/Feb 2021).

**ANIVI**  
ESTABLISHED IN 1939

**In search of top performance**



- |                 |                          |
|-----------------|--------------------------|
| <b>Systems:</b> | <b>Services:</b>         |
| - rotary drums  | - manufacturing          |
| - dryers        | - after sales            |
| - granulators   | - assistance             |
| - coolers       | - engineering            |
| - coating drums | - erection & supervision |
| - fluid beds    | - revampings             |
| - rotary kilns  |                          |
| - preheaters    |                          |

OTHER ANIVI DIVISIONS:  
Grinding & Classification    Air & Gases    Modular Systems



**ANIVI INGENIERIA, S.A.**  
Avda. Chorierrí, 8    48180 Loiu (SPAIN)  
Tel: +34 94 453 19 00    info@anivi.com    www.anivi.com



**CONTENTS**

What's in issue 371

**COVER FEATURE 1**

Waste gasification

**COVER FEATURE 2**

Nitrogen project listing

**COVER FEATURE 3**

'Blue' syngas technologies

**COVER FEATURE 4**

Improving ammonia plant economics

NITROGEN+SYNGAS  
**ISSUE 371**  
MAY-JUNE 2021

**BCInsight**

Southbank House, Black Prince Road  
London SE1 7SJ, England  
Tel: +44 (0)20 7793 2567  
Fax: +44 (0)20 7793 2577  
Web: www.bcinsight.com  
www.bcinsightsearch.com

# Improving the process economics of ammonia plant operations

The ammonia industry has always dealt with fluctuations in supply and demand as well as volatile feedstock and energy costs. The unexpected global pandemic that started in 2020 has injected a higher degree of uncertainty for ammonia manufacturers' operating costs and product demand for fertilizer. **W. Poe** of AVEVA discusses how advanced process control systems can help ammonia producers turn economic uncertainty into a competitive advantage.

In 2019, nearly 235 million tonnes of ammonia were produced worldwide with the fertilizer industry creating the greatest demand. The Covid-19 pandemic disrupted manufacturing activities and brought down the demand for ammonia. However, as economies are opening and the production of food and chemicals is rising, the demand for ammonia is expected to increase in the coming years<sup>2</sup>. Coupled with that, 107 new ammonia plants have been announced to start up through 2030 to increase global production capacity to nearly 290 million tonnes by 2030<sup>1</sup>. As a result, ammonia producers will continue to face an uncertain and highly competitive market environment for the years to come. Older plants in particular will be challenged to approach the efficiency of the new builds.

The widely adopted Haber-Bosch process for steam reforming relies heavily on natural gas as the source of hydrogen. Ammonia synthesis for the fertilizer industry is a process that demands significant energy to react the chemical species that form  $NH_3$ . Since nitrogen gas is strongly held together by triple bonded molecules, a large amount of energy is consumed to operate the system at the high temperatures and pressure required. The synthesis of nitrogen and hydrogen into ammonia is an energy intensive step in the ammonia production process that only realises a 10 to 20% conversion of gas per cycle, thereby requiring considerable recycle of

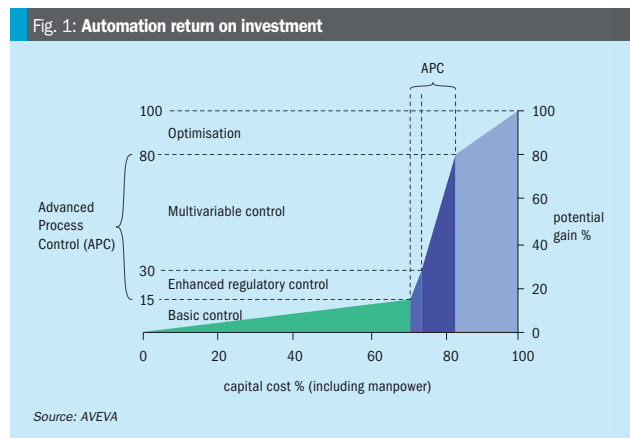

synthesis gas. Therefore, an ammonia plant generates the highest profitability when the hydrogen content of natural gas is converted most efficiently. As a result, the biggest impact on ammonia plant profitability is maximising yield at the lowest possible energy consumption per tonne of ammonia produced.

When existing fertilizer plants need to push operations to their maximum throughput, they are limited by the mechanical constraints and capabilities of process control systems. The target process parameters subject to multiple interactions, time delays, complex responses to changing conditions,

sparse or unreliable measurements, and variable cost structures are often difficult to maintain while honouring the mechanical limits with typical control strategies. In order to competitively meet market demand, ammonia plants must operate closer to the limits to maximise throughput and yield while minimising energy consumption. Increased profitability of ammonia plants is achieved using advanced process control (APC). APC reduces variability in the process, allowing the plant to run closer to constraints. Increased throughput at lower specific energy consumption and a consistent quality results in increased profit and competitive advantage.

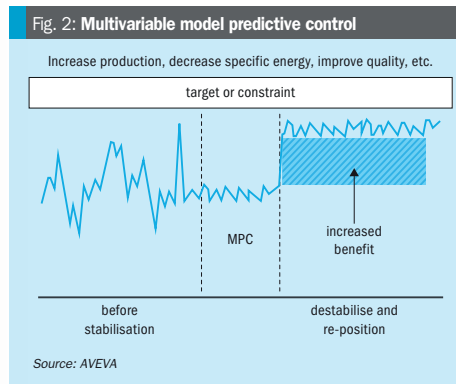

## Advanced process control

A study conducted by the Automation Research Council found that only about 15% of available automation benefits for manufacturing plants are captured with basic control systems despite the basic control system accounting for about 75% of the cost of automation. There is typically an additional 85% of ultimate automation benefits available with high return on investment for advanced process control and optimisation applications (see Fig. 1). A multivariable model predictive control also known as MPC presents the best cost-benefit relationship among all the automation layers.

Multivariable model predictive control achieves benefits by reducing variability in the outputs of an operation such as quality, production volumes and operating costs by identifying the sources of variability and responding to these disturbances (Fig. 2). This technology predicts the movement of the process and considers the operating targets and constraints as well as equipment limits that must be honoured for safe and reliable operation. With these predictions the technology can continually push the plant towards optimal targets with reduced variability and higher reliability.

When operators try to push the plant towards constraints, they may encounter instability or exceed the constraint. To avoid that, they will back off to a comfortable operating point away from that constraint and typically keep the process there for the remainder of their shift. The algorithms of MPC allow more elegant handling of constraints. When the predictive models anticipate that a

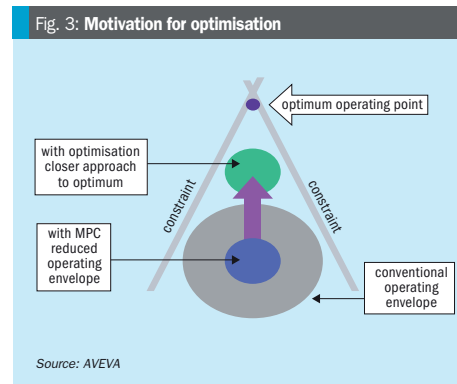

constraint will be encountered, it will take action to move right up to the constraint without exceeding it. The advanced controller will back off the constraint as conditions change, but only as much as necessary, and for as long as necessary. Then it will move right back up against the constraint.

By recognising and understanding the effect of different disturbances and setpoints on constraints, the widest range of stable process operations can be accessed, quality is improved and operating profit is increased.

Benefits of multivariable model predictive control can be summarised as follows:

- allows operation to be closer to limits by reducing variations;
- moves the process closer to multiple constraints (limits) simultaneously;
- provides access to a wide range of process operations;
- improves quality;
- increases operating profit by improving key metrics such as production rates and specific energy consumption.

Another way to look at the impact of model predictive control is in relation to multiple constraints. Optimum operating conditions are typically at the intersection of constraints. With the process variability experienced with basic proportional-integral-derivative controllers, operators must select setpoints that keep the plant within the boundaries of multiple constraints and therefore a wide operating envelope. With the reduced variability of model predictive control, the operating envelope is reduced and the process can be pushed closer to the optimal operating point (Fig. 3).

The model predictive controller contains dynamic models that describe the process responses, including time delays, interactions between inputs and outputs, and complex responses (inverse, integrating, etc.). Statistical methods are used to develop the predictive model relating input variables (disturbances and PID setpoints) and output variables (targets and constraints). As a result, the model can predict the future trajectory of the process outputs for any variation in the process inputs (Fig. 4).

By predicting the future variations, these models can continuously determine the setpoint adjustments required now to maintain targets and honour constraints. The underlying mathematics are quite complex and even more complex if nonlinear relationships are included with neural networks. Predictive models are either determined from plant tests or from data captured by the plant historian.

A powerful aspect of these models is their ability to understand the impact that a change in set point of any controller will have on other outputs not under its direct control. Also, as constraints change the controller reacts instantly to the situation.

## MPC applied to ammonia plants

The ammonia synthesis process lends itself nicely to model predictive control. The process has multiple reaction steps, high energy usage, interactions – especially in the synthesis loop with pressure, inerts, purge rate, large recycle and complex dynamics such as introduction of hydrogen at the primary reformer and nitrogen at the secondary reformer to control ratio at the synthesis converter inlet. A percent

Fig. 4: Model prediction for future trajectory of process outputs

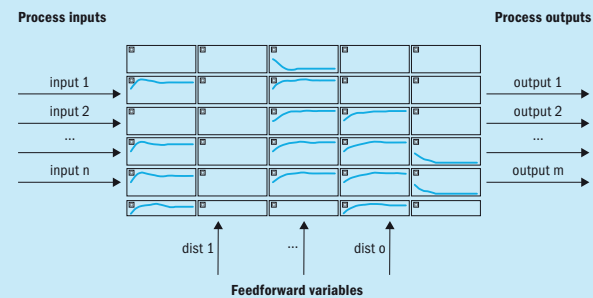

Source: AVEVA

increase in production or decrease in specific energy consumption can substantially improve the profitability of the operation. Typically, MPC applications for ammonia plants will result in 1% to 2% improvement in specific energy, and 1% to 4% production improvements.

Model predictive control can be implemented for several ammonia applications, as follows. The primary and secondary reformers, synthesis gas loop and ammonia synthesis reactor typically have the greatest value. Depending on individual plant operation and bottlenecks, the other units may have a good return on investment as well.

- primary and secondary reformers;
- carbon dioxide removal facilities;
- hydrogen (purge gas) recovery facilities;
- methanation system;
- synthesis gas loop;
- ammonia synthesis reactor;
- shift converters;
- steam system.

Many of the typical advanced process control or model predictive control objectives for ammonia plants are listed below:

- key performance indicators (KPIs);
- maximise unit throughput;
- minimise specific fuel gas and steam consumption;
- drivers for KPIs;
- control methane slip and balance primary reformer outlet temperatures;
- control converter inlet H/N ratio and total inerts concentrations within pressure constraints and hydrogen (purge) recovery constraints;
- control synthesis converter temperatures;

- control refrigeration capacity;
- qualitative benefits;
- enforce all specified operating and safety constraints;
- stabilise the unit operation in the presence of unmeasured disturbances;
- reduce operator workload.

The first two are overall objectives of the plant that are key metrics for the value that is generated with advanced process control. The next few are some of the key drivers to improve the overall key metrics. The final three are more qualitative outcomes. Note that any application should obey the process equipment operating constraints and certainly not compromise safety.

Stabilising the unit in the presence of unmeasured or seldom measured disturbances such as ambient temperature and pressure, feedstock changes and others help the controllability of the entire complex. It has also been proven to assist in faster unit start-up. Plant operators have many assigned tasks, including continually tweaking basic control setpoints values. This type of activity adds tension to the operators' daily work as many of the required adjustments are counter intuitive or need action much faster than the human brain can understand and execute. This type of solution helps the operators to better understand process behaviours, improving their effectiveness, and ultimately leading to higher job satisfaction.

**Case studies**

**Case study 1**

Case study 1 is based on an application deployed in an ammonia plant operated by a major producer in North America. This

plant started the journey on using APC with successful pilot projects on a urea desorber plant and a sister plant for the entire ammonia plant. After conducting a study to determine the potential benefits and cost, a project was initiated focusing on the front end of the plant for feed maximisation and energy savings. The project yielded savings of about \$750,000 per year due to ammonia production improvements and specific energy reduction. Payout was less than six months. The application has been in operation since 2005 and is being expanded to the synthesis loop and the urea plant.

**The challenge**

Improve utilisation and sustainability of urea desorber and ammonia units that produce 535,000 t/a of ammonia and 680,000 t/a of urea.

**The solution**

- Use model predictive control for:
- steam to gas ratio control;
  - excess oxygen control;
  - feed maximisation strategy.

**The benefits**

- ~\$750,000 per year in energy savings at industry average gas prices and energy consumption;
- 0.75% improvement in energy on a million Btu/t basis.

**Case study 2**

Case study 2 is based on an application deployed in an ammonia plant from another major producer in North America. It pertains to a site that desired to maximise ammonia production while enforcing operating and safety constraints. There were secondary objectives to reduce operator workload and specific energy consumption. A study was conducted at the site that included the cost and benefits of upgrade to a distributed control system and the identification of advanced process control benefits to justify the distributed control system installation. This study led to the installation of a distributed control system along with an extensive ammonia plant application that yielded 3-4% increase in ammonia production. The application was shortly thereafter expanded to all areas of the urea plant. In 2015 the plant capacity was expanded with a Kellogg Reforming Exchange System and the ammonia plant application modified accordingly. Advanced process control for the nitric acid plant is underway

Fig. 5: AI-driven predictive analytics

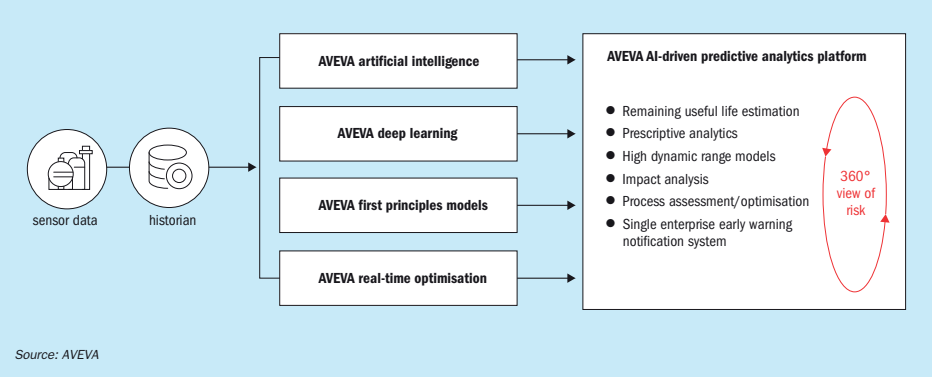

and they are also exploring opportunities for first principles-based optimisation.

**The challenge**

- maximise ammonia plant throughput and enforce specified operating/safety constraints;
- reduce operator workload and specific fuel gas and steam consumption.

**The solution**

Use model predictive control for:

- hydrogen to nitrogen ratio
- syngas suction pressure
- air compressor speed
- ammonia synthesis reactor temperature
- steam to carbon ratio
- feed flow control

**Benefits**

- 3-4% increase in ammonia production (in operation since 2006);
- expanded to urea plant, modified with KRES addition and now being installed on the nitric acid plant.

**Improving benefits beyond the MPC**

As mentioned before, the MPC is the main contributor to benefits related to plant automation. The MPC is also an important foundation to further optimise the ammonia plant. Once the process is stable through MPC, complementary models can be used to further optimise operations.

While the predictive models used for advanced process control are empirical dynamic models, first principles-based models can be added to the automation architecture. The most common first principles-based

models used for online applications are process performance monitoring, including adaptive reactor models and real-time optimisation models. They are continuously tuned to close the mass, energy and equilibrium balance, optimising operations according to the desired objective function, while keeping variables within the physical, operating and economic constraints. Typical objective functions for real time optimisation are minimising energy consumption or directly maximising plant profitability.

Another modelling approach that can be used is predictive analytics for equipment reliability with machine learning. In this case, the model is built based on historical data and can include process variables as mechanical variables.

The latest advancement in models for online applications is artificial intelligence (AI) driven predictive analytics, that combines AI such as machine learning, deep learning with artificial neural networks and rigorous first-principles models, and real-time optimisation (Fig. 5). AI-driven predictive analytics is infused with results from the rigorous process simulation and optimisation algorithms, creating a sophisticated model capable of providing advice about the most cost-effective choices for operations and maintenance based on a 360° view of risk.

**Summary**

Basic control systems capture about 15% of the potential automation benefits at about 75% of the total automation costs. Advanced process control captures the

most automation benefits with a high return on investment, and MPC is the main contributor to automation benefits.

There are many cases of the proven, sustainable benefits for ammonia plant operations. The main measurable benefits are production improvements of 1% to 4%, and 1% to 2% reduction in specific energy.

Other automation opportunities for nitrogen fertilizer plants include:

- first principles-based model for process performance monitoring;
- first principles-based model for real time optimisation;
- predictive analytics for equipment reliability with machine learning;
- AI-driven predictive analytics, combining AI, deep learning, rigorous first-principles models, and real-time optimisation.

**References**

1. Frahm B., Lin R. and Poe W.: "Improved ammonia plant safety via advanced process control systems". Nitrogen & Methanol No. 247, p. 25 (Sep-Oct 2000).
2. Lin R., de Boer R. and Poe W.: "Optimize ammonia plant operation". Hydrocarbon Processing. Vol. 78, 6, p. 91 (Jun 1999).
3. Grasdal K., Barone P. and Poe W.: "Benefits of advanced control to ammonia plant operations", AIChE Ammonia Safety Symposium, San Francisco, California, Paper Number 5E (Sep 22-24 1997).
4. Production capacity of ammonia worldwide in 2018 and 2030 - Statista (2021).
5. Worldwide Ammonia Industry to 2025 - Identify Drivers and Challenges - Business Wire, (Aug 2020).

# Advertisers' index

Advertiser	Page	Website
Air Liquide Global E&C Solutions	43	airliquide.com
ANIVI INGENIERÍA, S.A.	49	anivi.com
65th Annual Ammonia Safety Symposium	47	aiche.org/ammonia
Argus Media Co	21	argusmedia.com
Casale	11	casale.ch
Eurotecnica Contractors and Engineers	5	eurotecnica.it
Eurotecnica Contractors and Engineers	OBC	eurotecnica.it
Johnson Matthey	IFC	matthey.com/
Steinmüller Engineering	19	steinmueller.com
Sabin Metal Corporation	IBC	sabinmetal.com
Tecnimont Group	31	mairetecnimont.com/en
thyssenkrupp	17	thyssenkrupp-industrial-solutions.com/power-to-x

## Next issue: July/August 2021

- Syngas project listing
- Developments in ammonia plant safety
- Ammonia as a fuel
- Combatting material degradation in syngas and ammonia plants
- New reforming technologies

**Closing date for advertisement space booking is 25 June 2021**  
**For further information and to book advertisement space contact:**  
**Tina Firman, Publishing Director: [tina.firman@bcinsight.com](mailto:tina.firman@bcinsight.com)**  
**Tel: +44 (0)20 7793 2567 Fax: +44 (0)20 7793 2577**

**Editor:**  
 RICHARD HANDS  
[richard.hands@bcinsight.com](mailto:richard.hands@bcinsight.com)  
**Technical Editor:**  
 LISA CONNOCK  
[lisa.connock@bcinsight.com](mailto:lisa.connock@bcinsight.com)  
**Publishing Director:**  
 TINA FIRMAN  
[tina.firman@bcinsight.com](mailto:tina.firman@bcinsight.com)  
**Subscription rates:**  
 GBP 425; USD 850; EUR 655

**Subscription claims:**  
 Claims for non receipt of issues must be made within 3 months of the issue publication date.

**Sales/Marketing/Subscriptions:**  
 MARLENE VAZ  
 Tel: +44 (0)20 7793 2569  
 Fax: +44 (0)20 7793 2577  
[marlene.vaz@bcinsight.com](mailto:marlene.vaz@bcinsight.com)  
 Cheques payable to BCInsight Ltd

**Advertising enquiries:**  
 TINA FIRMAN  
[tina.firman@bcinsight.com](mailto:tina.firman@bcinsight.com)  
 Tel: +44 (0)20 7793 2567

**Agents:**  
**Japan:** (also subscription enquiries)  
 KOICHI OGAWA  
 O.T.O. Research Corporation  
 Takeuchi Building  
 1-34-12 Takadanobaba  
 Shinjuku-Ku, Tokyo 169, Japan  
 Tel: +81 3 3208 7821  
 Fax: +81 3 3200 2889

**Previous articles** from *Nitrogen+Syngas* and *Nitrogen & Methanol* from 1996 to the present are available digitally in PDF format. To make a purchase, or for a list of available articles, please see: [www.bcinsight.com](http://www.bcinsight.com)

**Copyright: Issued six times per year, or bi-monthly. All rights reserved. No part of this publication may be reproduced, stored in a retrieval system or transmitted in any form or by any means – electronic, mechanical, photocopying, recording or otherwise – without the prior written permission of the Copyright owner.**

ISSN: 1750-6891

**Design and production:**  
 JOHN CREEK, DANI HART



**Printed in England by:**  
 Buxton Press Ltd  
 Palace Road, Buxton, Derbyshire,  
 SK17 6AE

© 2021 – BCInsight Ltd

**BCInsight**

**Published by: BCInsight Ltd**  
 China Works, Unit 102,  
 100 Black Prince Road,  
 London SE1 7SJ, UK  
 Tel: +44 (0)20 7793 2567  
 Fax: +44 (0)20 7793 2577  
 Web: [www.bcinsight.com](http://www.bcinsight.com)  
[www.bcinsightsearch.com](http://www.bcinsightsearch.com)



## Refining — Precious Metals — Recycling

- ◆ Non-Destructive Cleaning
- ◆ Destructive PGM Recovery
- ◆ Filters and Sludge PGM Recovery
- ◆ Precious Metals Refining



1647 Wheatland Center Rd.  
 Scottsville, NY 14546, USA  
 Contact: [betsyg@sabinmetal.com](mailto:betsyg@sabinmetal.com)  
 Visit us at <https://sabinmetal.com/>

CONTENTS

What's in issue 371

COVER FEATURE 1

Waste gasification

COVER FEATURE 2

Nitrogen project listing

COVER FEATURE 3

'Blue' syngas technologies

COVER FEATURE 4

Improving ammonia plant economics

NITROGEN+SYNGAS  
**ISSUE 371**  
 MAY-JUNE 2021

**BCInsight**

Southbank House, Black Prince Road  
 London SE1 7SJ, England  
 Tel: +44 (0)20 7793 2567  
 Fax: +44 (0)20 7793 2577  
 Web: [www.bcinsight.com](http://www.bcinsight.com)  
[www.bcinsightsearch.com](http://www.bcinsightsearch.com)

1  
2  
3  
4  
5  
6  
7  
8  
9  
10  
11  
12  
13  
14  
15  
16  
17  
18  
19  
20  
21  
22  
23  
24  
25  
26  
27  
28  
29



# Euromel® Melamine The industry benchmark

24 plants worldwide. 5 million tonnes produced. No pollution. Euromel® is the world's leading melamine technology. Over the last 40 years, Eurotecnica has transformed the melamine market into a global operation by creating a melamine process that turns its Urea feedstock into a product that is profitable and in high demand.

Today, 24 melamine plants around the world have been licensed and implemented on the basis of Euromel®, with a combined annual capacity of more than 860,000 tons. Euromel® has also become the process with the lowest OPEX in the industry with zero-pollution, low energy consumption and no chemicals added for purification. Therefore investing in Euromel® means gaining access to a sustainable technology with a global network of producers.

Contact us at [www.euromel.com](http://www.euromel.com) to find out more.

**EUROMEL®**

[www.euromel.com](http://www.euromel.com)

**ET EUROTECNICA**  
MAKING SUSTAINABILITY PROFITABLE

## Don't forget the next issue of **Nitrogen+Syngas** July/August 2021

CONTENTS

What's in issue 371

COVER FEATURE 1

Waste gasification

COVER FEATURE 2

Nitrogen project listing

COVER FEATURE 3

'Blue' syngas technologies

COVER FEATURE 4

Improving ammonia plant economics

**NITROGEN+SYNGAS**  
**ISSUE 371**  
MAY-JUNE 2021

**BCInsight**

Southbank House, Black Prince Road  
London SE1 7SJ, England  
Tel: +44 (0)20 7793 2567  
Fax: +44 (0)20 7793 2577  
Web: [www.bcinsight.com](http://www.bcinsight.com)  
[www.bcinsightsearch.com](http://www.bcinsightsearch.com)