

1  
2  
3  
4  
5  
6  
7  
8  
9  
10  
11  
12  
13  
14  
15  
16  
17  
18  
19  
20  
21  
22  
23  
24  
25  
26  
27  
28  
29  
30  
31  
32  
33

# Welcome to our interactive version of **Nitrogen+Syngas** Issue 368

Please use either the buttons on the left or top right of the page to navigate your way around this interactive PDF

#### IMPORTANT INFORMATION:

Copyright – Issued six times per year, or bi-monthly. All rights reserved. No part of this publication may be reproduced, stored in a retrieval system or transmitted in any form or by any means – electronic, mechanical, photocopying, recording or otherwise – without the prior written permission of the Copyright owner.

Number 368

November | December 2020

# nitrogen + syngas

www.nitrogenandsyngas.com



The future of DME

Nitric acid carbon credits

Revamping ammonia plants

Plant digital solutions



CONTENTS

What's in issue 368

COVER FEATURE 1

The future of DME

COVER FEATURE 2

Nitric acid carbon credits

COVER FEATURE 3

Revamping ammonia plants

COVER FEATURE 4

Plant digital solutions

NITROGEN+SYNGAS  
**ISSUE 368**  
NOVEMBER-DECEMBER 2020

## BCInsight

Southbank House, Black Prince Road  
London SE1 7SJ, England  
Tel: +44 (0)20 7793 2567  
Fax: +44 (0)20 7793 2577  
Web: www.bcinsight.com  
www.bcinsightsearch.com

# JM

## Making a difference to the world around us

With years of operating experience and expertise across the syngas, petrochemical, oil and gas markets, Johnson Matthey continues to invest in technologies that improve processes whilst looking after the environment.

Our gas heated reforming technology is a proven energy efficient solution for syngas generation across multiple applications reducing both CO<sub>2</sub> emissions and raw water consumption, whilst maximising the opportunity to use renewable energy.

Contact us to find out how our technology can benefit your business.

**Johnson Matthey**  
Inspiring science, enhancing life

[www.matthey.com](http://www.matthey.com)



Cover: Ammonium storage tank at a refinery.

Bolbik/Shutterstock.com



### 10 Nitric acid emissions

NACAG aims to provide emissions credits for N<sub>2</sub>O abatement



### 16 Ammonia revamps

Strategies for modernising ammonia plants

Read this issue online at:  
[www.nitrogenandsyngas.com](http://www.nitrogenandsyngas.com)

Published by:

**BCInsight**

# nitrogen + syngas

[www.nitrogenandsyngas.com](http://www.nitrogenandsyngas.com)

NUMBER 368  
NOVEMBER | DECEMBER 2020

## CONTENTS

### 10 Tackling emissions in the nitric acid industry

Malte Plewa, Volker Schmidt, Daniel Ávila and Enrico Rubertus of German development agency GIZ and Dr. Silke Karcher of the German Environment Ministry (BMU) discuss action on climate change from nitric acid production and the Nitric Acid Climate Action Group (NACAG) and its global initiative for mitigating emissions.

### 12 The future of DME

A few years ago DME production from methanol gave a major boost to world methanol demand, with DME being used as a blendstock for LPG. However, demand plateaued and DME has not had the takeoff that its proponents feel it should have. Could new renewable DME processes give it the boost it needs?

### 14 A blueprint for 2025

Every five years since 1955, the Chinese government has prepared its 'Five Year Plan' for the country's economy over the coming half decade. This year, the 14th Five Year Plan is being drafted, and given the influence of the Chinese economy over the global chemical sector, its conclusions will be eagerly awaited.

### 15 A tumultuous year

A look back at some of the major events of 2020 for the nitrogen and syngas industries, as well as how 2021 might look.

### 16 New concepts for ammonia plant revamps

thyssenkrupp Industrial Solutions, KBR, Casale, Johnson Matthey and Arvos / Schmidtsche Schack discuss novel ways to revamp ammonia plants to bring a wide range of benefits.

### 26 Digital solutions bringing better performance

By harnessing the power of real-time data and exploiting the opportunities provided by digital solutions plant owners can achieve greater plant efficiency and reliability. Stamicarbon, OnPoint Digital Solutions, TOYO and thyssenkrupp Industrial Solutions report on their latest new digital solutions.

## REGULARS

3 Editorial The year we went digital

4 Price Trends

4 Market Outlook

5 Nitrogen Industry News

7 Syngas News

8 People/Calendar

9 Plant Manager+

Incident No. 3: Backflow in pressurised leak detection system for loose liner of HP scrubber

CONTENTS

What's in issue 368

COVER FEATURE 1

The future of DME

COVER FEATURE 2

Nitric acid carbon credits

COVER FEATURE 3

Revamping ammonia plants

COVER FEATURE 4

Plant digital solutions

NITROGEN+SYNGAS  
**ISSUE 368**  
NOVEMBER-DECEMBER 2020

**BCInsight**

Southbank House, Black Prince Road  
London SE1 7SJ, England

Tel: +44 (0)20 7793 2567

Fax: +44 (0)20 7793 2577

Web: [www.bcinsight.com](http://www.bcinsight.com)  
[www.bcinsightsearch.com](http://www.bcinsightsearch.com)

# The year we went digital



This year has been one of the stranger ones in my life, and I'm sure yours as well. Looking back from the perspective of late October 2020, I had no idea at the start of the year how much time I was going to be spending in my study rather than in the office or a hotel! Covid has forced major lifestyle changes upon all of us this year, and it has definitely accelerated some trends that were already making themselves felt, but which have suddenly become a major part of our forced adaptation to strange times. I haven't used cash since March, for example, except at one stubborn local takeaway that can't take contactless payments. Perhaps the greatest of these changes has been enforced remote working, and that has meant looking at digital technologies and the way we can use them. Even those of us who are, shall we say, not digital natives or early adopters, have had to become intimate with both the potential and the pitfalls of Zoom, Teams and all of the rest.

“Digitalisation also brings its own headaches.”

The chemical industry is also typically a very conservative one, and the bulk chemical industry more so than most sectors. It is not a virtual industry, but one where large volumes of very real material must be assembled, processed, and then distributed. When dealing with large quantities of reactive materials, the impulse to stick with the tried and tested can be a matter of safety as much as commerce, and when plant downtime can mean millions of dollars of lost production per day that it is not operational, and start-ups can take days, the impetus can run against major innovation. Change tends to be incremental rather than radical. Furthermore, large sunk costs and ageing infrastructure may mean that it is not possible for a company to take full advantage of the potential solutions on offer. Nevertheless, with licensors and contractors often not able to travel because of quarantine restrictions or even insurance issues, 2020 has forced new ways of working onto the industry as well, especially as regards plant construction and commissioning, but also for routine maintenance and advice.

As our article on pages 50-61 this issue shows, there are now a plethora of digital solutions being offered by companies involved in the nitrogen and syngas sectors. As distributed control systems have spread across plants both old and new, so

this has greatly increased the amount of data that can be harvested by plant operators. Of course, as my old chemistry professor would have said – “data is not information” – and the means of transforming the one into the other are a variety of modelling and analysis software and artificial intelligence applications such as neural networks, from process simulation via ‘digital twin’ plants to operational optimisation and predictive maintenance scheduling. The advent of the ‘internet of things’, smart sensors, ‘big analytics’, data visualisation and a host of other related technologies has led to the concept of ‘Industry 4.0’, where computers are able to make decentralised decisions without human intervention, with ‘human in the loop’ monitoring only for higher level functions.

But of course, digitisation also brings its own headaches; new vulnerabilities, security risks and potential points of failure, which are especially concerning for safety critical systems. It brings issues such as cyber-security and handling of sensitive data to the fore, and the digital architecture of a company's intranet, and how that interacts with the outside world, are part and parcel of the new world that we are operating in.

Perhaps it's my age, but it's hard not to feel sometimes that we are losing something as well as gaining it. A teleconference can't carry the nuance of a face to face meeting, and perhaps a feed from a plant monitoring suite isn't quite the same as walking around a site and examining the pipework. Still, the economics speak for themselves, and it is a trend that can only accelerate as we enter the decade ahead.

Richard Hands, Editor



## Euromel® Melamine The industry benchmark

23 plants worldwide, 5 million tonnes produced. No pollution. Euromel® is the world's leading melamine technology. Over the last 40 years, Eurotecnic has transformed the melamine market into a global operation by creating a melamine process that turns its Urea feedstock into a product that is profitable and in high demand.

Today, 23 melamine plants around the world have been licensed and implemented on the basis of Euromel®, with a combined annual capacity of nearly 800,000 tons. Euromel® has also become the process with the lowest OPEX in the industry with zero-pollution, low energy consumption and no chemicals added for purification. Therefore investing in Euromel® means gaining access to a sustainable technology with a global network of producers.

Contact us at [www.euromel.com](http://www.euromel.com) to find out more.

EUROMEL®

EUROTECNICA  
MAKING SUSTAINABILITY PROFITABLE

CONTENTS

What's in issue 368

COVER FEATURE 1

The future of DME

COVER FEATURE 2

Nitric acid carbon credits

COVER FEATURE 3

Revamping ammonia plants

COVER FEATURE 4

Plant digital solutions

NITROGEN+SYNGAS  
ISSUE 368  
NOVEMBER-DECEMBER 2020

BCInsight

Southbank House, Black Prince Road  
London SE1 7SJ, England  
Tel: +44 (0)20 7793 2567  
Fax: +44 (0)20 7793 2577  
Web: [www.bcinsight.com](http://www.bcinsight.com)  
[www.bcinsightsearch.com](http://www.bcinsightsearch.com)

# Price trends



## MARKET INSIGHT

**Alistair Wallace**, Head of Fertilizer Research, Argus Media, assesses price trends and the market outlook for nitrogen.

### NITROGEN

Prices are static in the ammonia market, with minimal activity reported at the end of October, but negotiations are ongoing for spot cargoes in November and December. In Europe, rising gas prices are firming feedstock costs and supporting current price levels despite relatively slow demand from key consumption regions. In China, firmer prices are reported from caprolactam, acrylonitrile and fertilizer markets, making exports a more attractive prospect for the remaining months of the year. Chinese exports continue to run about 5% ahead of last year in the Middle East, Saudi producer Sabic has positioned its turnaround at the Ibn Baytar plant from early November to 27 November, and will lose 60,000 tonnes of production from the turnaround. In Trinidad, Nutrien is scheduled to idle its smallest plant and the timing of the restart of its largest plant is still unknown.

Argus expects supply availability to improve through December, based on producers coming back on line, as prices towards the end of the year provide enough incentive to ramp plants back up towards full production. Outages in Trinidad and Algeria have given the market some balance, but if production does ramp back up, prices could come under pressure again.

Urea prices came under pressure in the second half of September from a number

of factors – India’s tender was announced later than expected, Chinese export supply proved larger than anticipated, and a lack of trade west of Suez continued to depress f.o.b. values. Some European buying started in late September when prices fell to more acceptable levels. More recently, India’s RCF set a new record, awarding 2.18 million tonnes – the first time purchases have exceeded 2 million tonnes in a single tender. Chinese prices rose at the end of October, driven by a spiralling domestic market. Egyptian prices were reconfirmed in the mid \$250s/t f.o.b. by a fresh spot sale. Brazil remained a weak point, however, with prices drifting below \$265/t c.fr amid minimal liquidity. Europe was equally quiet with buyers mostly awaiting lower values. The void in liquidity outside of India means the direction of the market over the medium term will be decided by its timing. India still needs substantial imports for the rabi application season. However, if it takes a lengthy pause before tendering again, there is little to sustain prices in the interim, based on current evidence.

Strong demand from India will provide an outlet for Middle East and Chinese suppliers. In the west, fourth-quarter demand from Europe and Brazil will be key to granular prices. Suppliers are comfortable for now, but prices will likely come under pressure in between Indian tenders.

Table 1: Price indications

Cash equivalent	mid-Oct	mid-Aug	mid-Jun	mid-Apr
<b>Ammonia (\$/t)</b>				
f.o.b. Black Sea	200-210	178-205	180-200	210-225
f.o.b. Caribbean	180-190	160-175	175-190	200-215
f.o.b. Arab Gulf	230-260	230-260	180-200	200-220
c.fr N.W. Europe	225-255	210-250	220-245	250-281
<b>Urea (\$/t)</b>				
f.o.b. bulk Black Sea	230-245	230-253	195-215	215-228
f.o.b. bulk Arab Gulf*	249-270	264-285	219-245	226-245
f.o.b. NOLA barge (metric tonnes)	238	230-240	213-218	263
f.o.b. bagged China	265-290	275-295	242-263	250-283
<b>DAP (\$/t)</b>				
f.o.b. bulk US Gulf	367-395	353-390	293-304	297-323
<b>UAN (€/tonne)</b>				
f.o.t. ex-tank Rouen, 30%N	157	157	163-165	172

Notes: n.a. price not available at time of going to press. n.m. no market. \* high-end granular.

## END OF MONTH SPOT PRICES

### natural gas

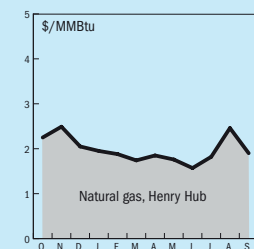

### ammonia

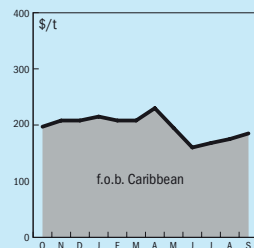

### urea

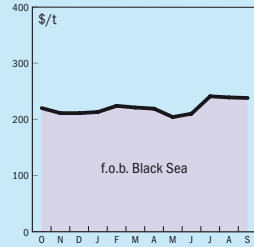

### diammonium phosphate

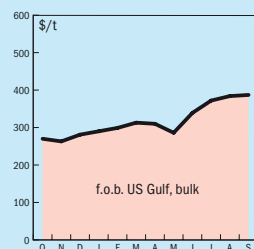

# Market Outlook

## Historical price trends \$/tonne

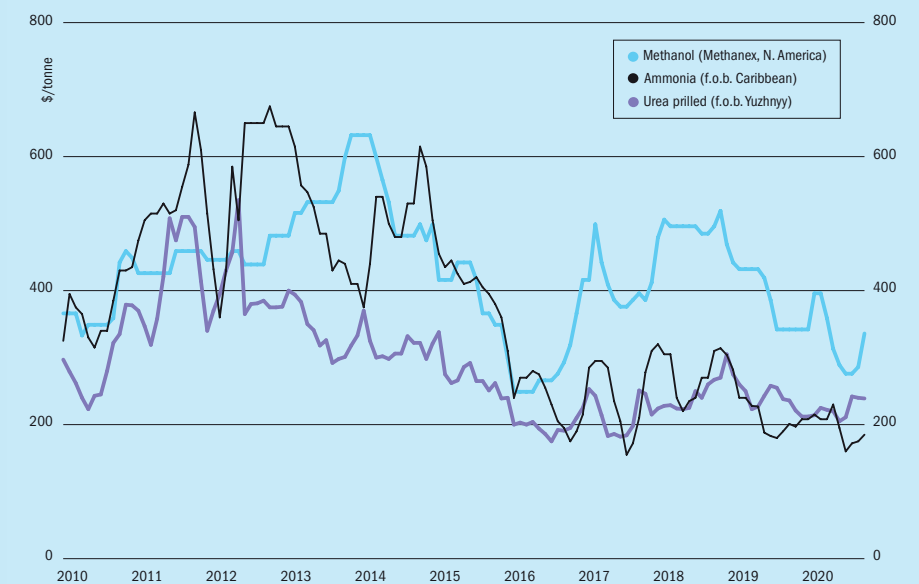

Source: BCI Insight

### AMMONIA

- Ammonia prices have been on a rising trend over the past few months as plant closures begin to make themselves felt. Yara’s Baltic ammonia price also rose sharply at the start of October, and Nutrien’s announcement of the closure of its PCS-03 plant on Trinidad helped lift prices, with Yara and Mosaic’s contract prices rising \$16/t in October.
- Trinidadian exports were reported to be down 17% on 2019’s figures by the end of August, at 2.67 million tonnes, and the closure of PCS-03 reduces the island’s notional ammonia capacity to 4.1 million t/a.
- Middle Eastern producers have had no problem finding buyers for their ammonia, though many markets have been quiet and buying for the US fall application season is largely complete.
- Now that rising prices are starting to lead to producers coming back on line, including export-oriented capacity in Indonesia, the market could find itself quite weak to the end of the year.

### UREA

- Indian buying has been the dominant factor in urea pricing over the past couple of months. Strong buying at the end of August kept prices buoyant, but when India took a step back from the market in September rates sagged again, before picking up in early October when India made some more large purchases. The RCF tender attracted a record 3.6 million tonnes of offers. Indian buying looks set to continue to determine the fate of a volatile market going forward.
- The Chinese application season is largely over now, and Chinese producers are likely to have more urea available for the international market, leading to potential market softening.
- Fourth-quarter demand from Europe and Brazil will be the key to prices for granular urea. Suppliers are comfortable for now, but prices will likely come under pressure in between Indian tenders.
- The start-up of the first train at the Dangote site in Lekki, now expected to be

in November, will also bring more supply to the market over the coming months.

### METHANOL

- Methanol prices have improved during Q3 2020. Autumn is traditionally a stronger season for methanol demand anyway, and demand has picked up strongly again following Covid-related shutdowns in key demand sectors earlier in the year.
- Methanex reported Q3 revenues down 24% for the quarter compared to the same period in 2019, mainly because of much lower prices this year.
- A number of shutdowns or turnarounds of major methanol plants around the world, especially in China, where prices had fallen below marginal costs of production, have also contributed to the recovery in prices, as well as unplanned outages in Southeast Asia and the Middle East.
- The spectre of a ‘second wave’ of Covid lockdowns across Europe and North America continues to darken the outlook, however, and the pace of global economic recovery and methanol demand remains uncertain.

## CONTENTS

What’s in issue 368

### COVER FEATURE 1

The future of DME

### COVER FEATURE 2

Nitric acid carbon credits

### COVER FEATURE 3

Revamping ammonia plants

### COVER FEATURE 4

Plant digital solutions

NITROGEN+SYNGAS  
**ISSUE 368**  
NOVEMBER-DECEMBER 2020

**BCInsight**

Southbank House, Black Prince Road  
London SE1 7SJ, England  
Tel: +44 (0)20 7793 2567  
Fax: +44 (0)20 7793 2577  
Web: www.bcinsight.com  
www.bcinsightsearch.com

## UNITED STATES

### EPA and USDA competition for new fertilizer technologies

The US Environmental Protection Agency (EPA) and the US Department of Agriculture (USDA) have announced the 'Next Gen Fertilizer Challenge', a joint EPA-USDA partnership and competition to advance agricultural sustainability in the United States. The competition includes two challenges that seek proposals for new and existing fertilizer technologies to maintain or improve crop yields while reducing the impacts of fertilizers on the environment.

"The shared goal here is to accelerate the development of next-generation fertilizers for corn production that can either maintain or increase crop yields while reducing environmental impacts to our air, land, and water," EPA Administrator Andrew Wheeler said.

"USDA is committed to encouraging the development of new technologies and practices to ensure that US agriculture is socially, environmentally, and economically sustainable for years to come," Secretary of Agriculture Sonny Perdue said. "This challenge will stimulate innovation and aligns with USDA's Agriculture Innovation Agenda announced earlier this year."

Jennifer Orme-Zavaleta, the EPA's Principal Deputy Assistant Administrator for Science and Science Advisor added: "By evaluating the efficacy of existing technologies while sparking research and development of new technologies, these challenges explore the potential innovation that can result from academia, industry, government, and NGOs working together to

address the complex issues related to excess nutrients in our environment."

Along with EPA and USDA, the competition is coordinated with The Fertilizer Institute, the International Fertilizer Development Center, the National Corn Growers Association, and The Nature Conservancy.

The first challenge, the Environmental and Agronomic Challenge, aims to identify existing Enhanced Efficiency Fertilizers (EEFs) that meet or exceed certain environmental and agro-economic criteria. EEF is a term for new formulations that control fertilizer release or alter reactions that reduce nutrient losses to the environment. This challenge will not have a monetary prize, but winners will receive scientific evaluation of their product and recognition from EPA, USDA, and other collaborators and participants.

The second challenge, the Next Gen Fertilizer Innovations Challenge, aims to generate new concepts for novel technologies that can help address environmental concerns surrounding agriculture practices while maintaining or increasing crop yields. A panel of expert judges will review the submissions. Each winner will receive at least \$10,000.

The Next Gen Fertilizer Challenge opened on August 26th, 2020. Registrants must submit their entries by October 30th, 2020, for the Environmental and Agronomic Challenge and by November 30th, 2020, for the Next Gen Fertilizer Innovations Challenge. Winners will be announced in the winter of 2021. ■

### Large scale 'carbon free' ammonia plant

Chemical technology company Monolith Materials says that it plans to use its proprietary methane pyrolysis process to build a large scale (approximately 275,000 t/a) 'carbon-free' ammonia plant in Nebraska. The company, founded in 2012, has patented a process technology which converts natural gas into carbon black and hydrogen, producing around 3 tonnes of solid carbon per tonne of hydrogen, but avoiding CO<sub>2</sub> emissions to atmosphere. The company's first commercial-scale plant, Olive Creek 1 (OC1), is currently in commissioning, and will produce approximately 14,000 t/a of carbon black. With the next phase of its facilities, the company plans to use the hydrogen generated via its manufacturing process to cleanly produce ammonia and potentially a wide array of other products that require hydrogen.

"Since its inception, Monolith Materials has been committed to developing solutions that are environmentally transformative, technologically advanced and financially viable," said Rob Hanson, CEO of Monolith Materials and the company's

co-founder. "Being able to produce one of the world's most essential products in a way that is carbon-free is a significant step not only for our company, but for the industry and even society as a whole."

Hallam, Nebraska, home to the new plant, sits in the US Corn Belt, where a handful of states import over 1/7 million t/a of ammonia for agricultural use. Monolith says Olive Creek 2 will integrate with a new 180,000 t/a carbon black facility, and avoid the generation of 1 million t/a of carbon dioxide in the production of its 275,000 t/a of ammonia. The plant will also use 100% renewable electricity for its power train. Construction is expected to begin in 2021.

"This is great news for 21st-century agriculture, where we face the challenge of decarbonising age-old processes at the same time as we must scale up production to keep pace with population growth," said Trevor Brown, executive director of the Ammonia Energy Association. "We need to deploy every available technology to accelerate this energy transition and Monolith's methane pyrolysis process has potential to deliver low-carbon ammonia in the right place at the right scale and at the right cost."

### CF to boost nitric acid production at Donaldsonville

CF Industries says that it will invest \$42.4 million to enhance nitric acid production at the Donaldsonville nitrogen fertilizer complex. Donaldsonville is the largest nitrogen complex in the world, with six world-scale ammonia plants, five urea plants, four nitric acid plants, three urea ammonium nitrate (UAN) plants and a diesel exhaust fluid (DEF) plant. The current project will increase the concentration of industrial-grade nitric acid at the site from 60% to 65% in the Nitric Acid No. 4 plant, which has a capacity of 600,000 t/a. The investment also will include the addition of an air chiller and the installation of product storage, as well as new rail car and truck loading.



CF Industries' nitrogen complex at Donaldsonville, Louisiana.

"CF Industries is pleased to continue our long history of investing in and expanding our Donaldsonville Nitrogen Complex and creating jobs in Louisiana," president and CEO Tony Will said. "The capital investment we are making to enhance nitric acid production at the site will further expand Donaldsonville's production flexibility and enable us to meet strong demand for the product, particularly from Louisiana's strong chemicals industry."

## DENMARK

### Topsoe to refocus its strategy

Haldor Topsoe is reorganising in order to pursue a new strategic direction. As part of its new focus, the company is aiming to be recognised as the global leader in carbon emission reduction technologies by 2024. It is also aiming to be more customer facing, with a strong commercial set-up, effective production, and innovation to deliver technologies demanded by the market.

"We have designed an organisation with a clear focus on accelerating the development of carbon-neutral technologies, and it will be funded by continued delivery of Topsoe's globally leading solutions for energy-efficient production of conventional fuels and chemicals," said Roeland Baan, CEO of Haldor Topsoe. "This transformation has a very strong foundation in our exceptional R&D capabilities, world-leading technologies, and a long standing dedication to making a positive difference in the world by perfecting chemistry."

Many employees will get new responsibilities as departments and business

areas are refocused to deliver on the vision, which will also result in approximately 200 redundancies.

"It is never easy to let talented employees go. I want to thank them all for being part of making Topsoe a success," said Baan. "With our new organization in place, I am confident that Topsoe has come closer to taking a decisive role globally. The world is at a climate crossroads, and Topsoe delivers technologies that target some of the most pressing challenges. Now, we have taken the first step on a very ambitious journey defined by our new vision, and we have what it takes to reach our goal."

The new organization will be effective from November 1st, 2020.

## NETHERLANDS

### Large-scale electrolyser for ammonia plant

Danish wind power company Ørsted A/S is to partner with Yara International ASA to develop a 100 MW electrolyser and produce green hydrogen for the fertiliser producer's ammonia production in the Netherlands. The electrolyser, to be powered by energy from Ørsted's 750 MW Borssele 1 and II offshore wind farms, will replace fossil fuel-based hydrogen to produce green ammonia at Yara's plant at Sluiskil.

Ørsted said the companies will seek public co-funding to develop and build the electrolyser facility. Depending on sufficient funding and a confirmed business case, the partners could take the final investment decision in late 2021 or early 2022, in which case the project could be operational in 2024/25. If the project

comes to fruition, the renewable hydrogen would generate some 75,000 t/a of green ammonia per year, or around 10% of the capacity of one of the ammonia plants in Sluiskil.

## JAPAN

### Joint research on ammonia-fuelled ship

NYK, IHI Power Systems Co., Ltd., and Nippon Kaiji Kyokai (ClassNK) have signed a joint research and development agreement to develop ammonia-fuelled shipping in order to meet International Maritime Organization (IMO) decarbonisation targets for shipping by 2050. Since carbon dioxide is not emitted when ammonia is burned, it is seen as a potential next-generation fuel that could mitigate shipping's impact on global warming, provided that zero emissions can be realized by using CO<sub>2</sub>-free hydrogen as a raw material for ammonia production.

The companies have decided to begin the joint R&D project with an ammonia-fuelled tugboat, based on work that the companies conducted in 2015 on an LNG-fuelled tug, the Sakigake. The programme envisages that financial year 2020 will be spent on technological development of the hull, engine, and fuel supply system, and development of safe navigation methods, following which they will begin study of the construction of the ammonia-fuelled tug and the plan for construction. NYK Line will be responsible for research and design of the hull and fuel supply system, IHI Power Systems for research and design of the engine and exhaust gas after-treatment, and Nippon Kaiji Kyokai (ClassNK) for safety assessment.



## Rely on Good Experiences.

Your reliable partner through all stages of plant engineering in the fields of waste heat boilers and process gas coolers for nitric acid, ammonia, methanol and other applications.

steinmüller  
engineering  
The Engineers Company

www.steiueller.com Tel: +49 (0) 2261 / 789 50-0

## CONTENTS

What's in issue 368

## COVER FEATURE 1

The future of DME

## COVER FEATURE 2

Nitric acid carbon credits

## COVER FEATURE 3

Revamping ammonia plants

## COVER FEATURE 4

Plant digital solutions

NITROGEN+SYNGAS  
ISSUE 368  
NOVEMBER-DECEMBER 2020

# BCInsight

Southbank House, Black Prince Road  
London SE1 7SJ, England

Tel: +44 (0)20 7793 2567

Fax: +44 (0)20 7793 2577

Web: www.bcinsight.com  
www.bcinsightsearch.com

**CHILE**

**Green ammonia project for Enaex**

Energy giant Engie and Chilean ammonium nitrate producer Enaex are looking at the construction of a solar-powered ammonia facility. The companies entered into a strategic alliance to investigate the feasibility of green ammonia production from renewable hydrogen in July 2019. The HyEx project is ultimately considering a 2,000 MW solar farm which would power a 1,600 MW hydrogen electrolysis plant to produce 124,000 t/a of green hydrogen. This in turn would be fed to an ammonia plant with a capacity of 700,000 t/a, of which half would be fed to Enaex's ammonium nitrate plant and the rest supplied for fuel, green fertiliser production and the export market. However, full scale operation is not expected before 2030, and the initial pilot facility would include a 36 MW solar plant, a 26 MW hydrogen electrolyser and 18,000 t/a of ammonia production, with a target completion date of 2024.

Enaex's ammonium nitrate plant is in the Mejillones district in the Antofagasta province in Chile's north, about 1,400 km north of Santiago, the centre of the country's copper mining industry. Currently the ammonia for the plant is imported.

Engie is also working with Australian mining technology developer Mining3 to co-develop hydrogen solutions for the mining industry. The first of these, the Hydra project, is to develop a new power train and refuelling system for mining vehicles to run on methanol produced from green hydrogen instead of diesel. Hydra has been awarded \$320,000 funding by the Chilean economic development agency CORFO to support design and development studies. The goal is to scale up the solution to convert mining vehicles at several mining sites in Chile using hydrogen from wind farms in Cabo Negro north of Punta Arenas in the south of Chile to produce green methanol and fuel for transport. The initial production targeted is 350 t/a of green methanol and 250 t/a of carbon neutral fuel.

**SAUDI ARABIA**

**CO<sub>2</sub> removal facility for Ma'aden**

Daelim Industrial says that it has successfully installed a carbon dioxide removal facility at the new ammonia production plant it is building in Saudi Arabia. The site is located at Ras al-Khair, 80 km north of Jubail on the east coast of Saudi Arabia. The \$960 mil-

ion project was awarded by state-run mining company Ma'aden, and is being carried out by Daelim Industrial on an EPC lump sum turnkey basis. Ground was broken in November 2018 and 61% of the work has been done. Daelim says that it will complete the project in the second half of 2021.

**'Blue' ammonia shipment to Japan**

Saudi Aramco says that it has made the world's first shipment of 40 tonnes of 'blue' ammonia to Japan, where it will be used in power stations to produce electricity without carbon emissions. Aramco produced the ammonia from natural gas with capture of the associated carbon dioxide for enhanced oil recovery (EOR).

**TRINIDAD & TOBAGO**

**Nutrien ammonia plant closed "indefinitely"**

Nutrien says that it has closed PCS-03, one of its for ammonia plants on Trinidad, for an indefinite period, with the layoff of 50 workers, due to low ammonia prices. The company's other two plants and the associated urea facility will continue to operate at maximum capacity, it added. Another plant, PCS-02, was taken offline in May due to market conditions and is expected to come back online as conditions improve. The company added that it will be ensuring customers will be supported and there are no changes to existing supplier contractual agreements.

**CHINA**

**Training on cloud-based urea plant simulator**

Stamicarbon says that Hubei Sanning Chemical Industrial Co., Ltd at Zhijiang will be its first client to receive operator training remotely; in this case an intensive five day training course with multiple operator trainees simulating the plant operation simultaneously. The training uses a urea plant simulator with cloud solution (made with Protomation technology), enabling operator training to be performed remotely. This allows Stamicarbon to gain a deeper understanding of plant process dynamics, which in turn leads to process improvements, knowledge feedback and improved start-up training for operators. Urea plants designed with Stamicarbon's Ultra Low Energy Design (ULED) such as the one under construction at Sanning, come with the urea simulator built-in.

"This is really exciting. We can now give operators hands-on training and help them to be well prepared, without physically being there," said Rahul Patil, Senior Process Engineer at Stamicarbon. "Especially in the current situation, with continuing travel restrictions, we are pleased to be able to support our clients remotely."

**INDIA**

**Bids invited for settlement of Matix debt**

A consortium of lenders led by IDBI Bank has invited bids for settlement of their outstanding debt of around \$600 million to Matix Fertilisers and Chemicals Ltd (MFCL) after they received a one-time settlement offer (OTS) from the company. The eleven-lender consortium, which around 70% of the outstanding debt in the company, has agreed for settlement of the debt against the OTS offer based on the "Swiss Challenge" process according to SBI Capital Market, whom the other lenders have mandated to resolve the company's outstanding debt.

Matix operates a 730,000 t/a gas-based ammonia plant at Panagarh Industrial Park, West Bengal with 1.27 million t/a of downstream urea capacity, as well as a 54 MW captive power plant, water reservoir, railway siding, steam generation and other utilities. It was due to begin operations in 2014 based on local coal-bed methane to be supplied by Essar Oil Ltd. However, when that supply was not forthcoming, it was only able to operate for 45 days in late 2017 and had to suspend operations due to a lack of working capital and availability of adequate gas, leading Matix to subsequently default on its debt.

**BRAZIL**

**Petrobras to sell Araucaria**

Petrobras has begun the process of selling its fertilizer subsidiary Araucária Nitrogenados SA, located in the state of Parana. The state-run oil giant plans to sell all 100% of its operating interest in the company, as part of its strategy to cut costs and improve its capital position, which has been worsened by low oil prices and the Covid pandemic. Petrobras continues to carry \$87 billion in outstanding debt.

Araucária has a total capacity of 1,975 t/d of urea and 1,303 t/d of ammonia, but has been shut down for economic reasons since January 2020. Petrobras says that any buyer will be responsible for whatever work is required to restart production. ■

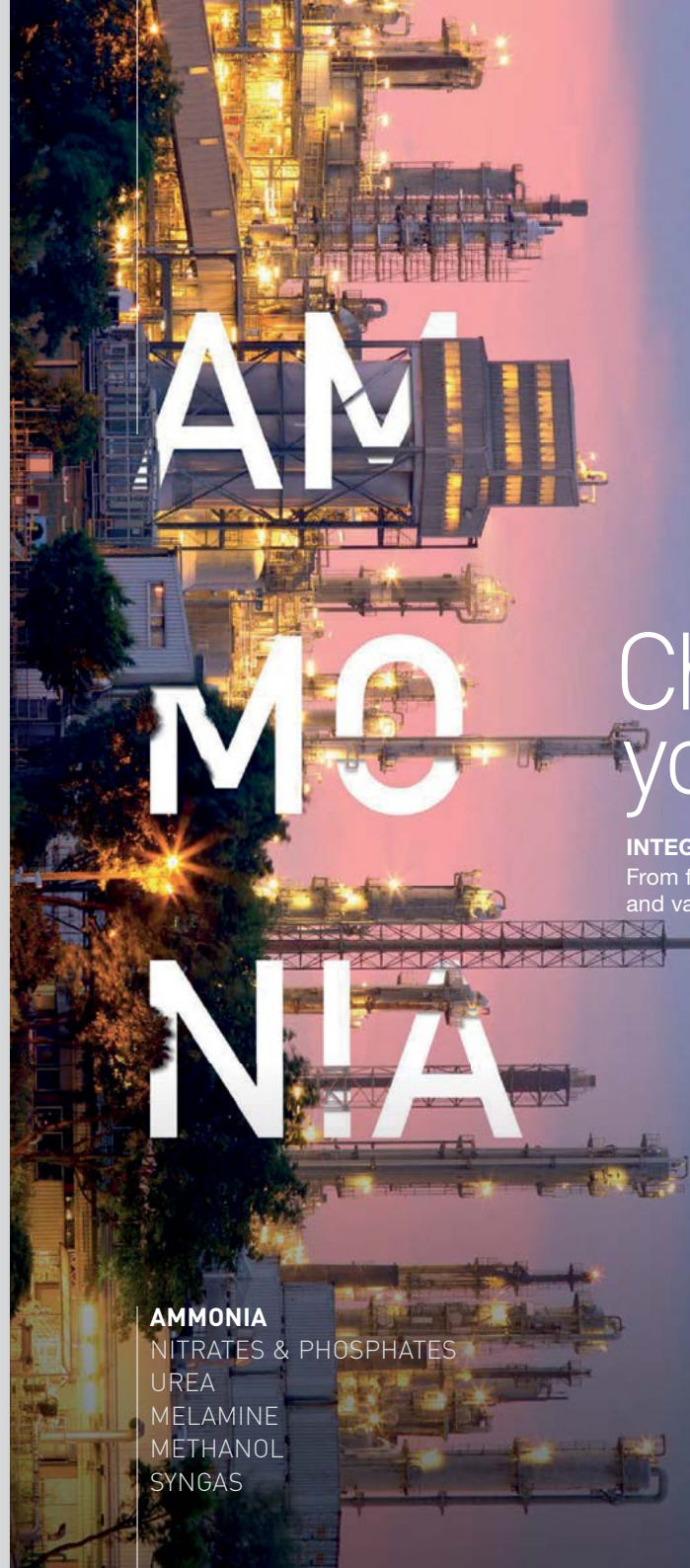

Change your vision

**INTEGRATED PROCESS**  
From feedstocks to any fertilizers and valuable chemicals.

**AMMONIA**  
NITRATES & PHOSPHATES  
UREA  
MELAMINE  
METHANOL  
SYNGAS



www.casale.ch  
info@casale.ch

**CONTENTS**

What's in issue 368

**COVER FEATURE 1**

The future of DME

**COVER FEATURE 2**

Nitric acid carbon credits

**COVER FEATURE 3**

Revamping ammonia plants

**COVER FEATURE 4**

Plant digital solutions

**NITROGEN+SYNGAS**  
**ISSUE 368**  
NOVEMBER-DECEMBER 2020

**BCInsight**

Southbank House, Black Prince Road  
London SE1 7SJ, England  
Tel: +44 (0)20 7793 2567  
Fax: +44 (0)20 7793 2577  
Web: www.bcinsight.com  
www.bcinsightsearch.com

Relax,  
it's Venti.



We save energy  
and improve  
efficiency.

To modernise existing production systems, Venti Oelde supplies fans equipped with special impellers offering the highest energy efficiency and a reduced sound level. By optimising the inflow and outflow as well as the regulation, Venti achieves considerable energy savings of up to 25%.

Detailed system check  
Improved cost effectiveness  
High operational safety

High-tech fans  
made  
in Germany



We make air work for you | www.venti-oelde.com

UNITED KINGDOM

## Johnson Matthey and KBR alliance on ammonia-methanol co-production

Johnson Matthey and KBR have announced that they have signed a global strategic alliance agreement to license a new ammonia-methanol co-production process that combines the companies' ammonia and methanol process technologies. The companies say that the co-production process makes the most of synergies between the two technologies, maximising savings while offering the highest levels of safety, flexibility and reliability.

The process combines JM's proven methanol production process and KBR's proprietary PURIFIER™ ammonia process, eliminating duplication of equipment compared to two stand-alone plants, reducing capital expenditure. The synergies between the two technologies reduces the environmental impact of the plant and its operating expense through shared utilities and lower energy consumption, while the process grants the operator the flexibility to optimise production and adjust to opportunities within the marketplace, as opposed to separate plants tied to one dedicated product.

"I am excited to announce the alliance agreement combining market leading technologies from KBR and JM into a new offering for our clients," said Doug Kelly, KBR President, Technology Solutions. "KBR's ammonia technology is known for its lowest energy consumption resulting in reduced carbon footprint, highest reliability and safety and outstanding financial performance."

"Methanol and ammonia hold great promise for continued energy and fuels transition to a greener world. This strategic agreement is a powerful combination that provides our customers a comprehensive solution for enhanced asset optimization, cost savings and reduced environmental impact," said John Gordon, Managing Director for Johnson Matthey. "Our partnership with KBR takes ammonia-methanol production to the next step with a single point license that delivers innovative operational agility to meet ever changing market demand."

## Carbon capture hydrogen plant submits proposal

Plans to transform Humberside, the UK's largest and most carbon-intensive industrial region, into the world's first net zero industrial cluster by 2040 have taken a step forward today after the consortium of companies behind the project submitted a £75 million (\$100 million) proposal to the UK Government's Industrial Strategy Challenge Fund. The bid by the Zero Carbon Humber (ZCH) Partnership centres around two elements: a plant that produces hydrogen from natural gas and a hydrogen and carbon dioxide (CO<sub>2</sub>) pipeline network. Equinor-led Saltend (Hydrogen to Humber) Saltend, at Saltend Chemicals Park near the city of Hull, will be largest plant of its kind in the world to convert natural gas to hydrogen. It will combine a 60 OMM autothermal reformer with carbon capture, reducing industrial emissions by nearly 900,000 t/a.

The second element is the hydrogen and CO<sub>2</sub> pipeline network developed by National Grid Ventures that aims to link

H2H Saltend to other industrial sites in the Humber region, enabling them in turn to fuel switch to hydrogen or capture their emissions. These sites include Drax Power station, SSE Thermal's Keadby site, Uniper's Killingholme site and British Steel at Scunthorpe.

The ZCH Partnership comprises Equinor, Associated British Ports, British Steel, Centrica Storage Ltd, Drax Group, Mitsubishi, National Grid Ventures, px Group, SSE Thermal, Saltend Cogeneration Company Limited, Uniper, and the University of Sheffield's Advanced Manufacturing Centre (AMRC).

"Our bid demonstrates the kind of ambitious action that is needed to for the UK to achieve its net zero carbon target by 2050," said Al Cook, Equinor Executive Vice-President and UK Country Manager.

"We believe in the necessity of hydrogen and carbon capture to clean up heavy industry which is required to reach net zero targets," added Grete Tveit, Equinor Senior Vice-President for low carbon solutions. "The technologies are proven and it's now a question of putting them together."

NORWAY

## Fuel cell offers alternate power train for shipping

Maritime technology partners have developed a 1.2 MW prototype fuel cell propulsion system which can use a variety of different types of fuel, including LNG and ammonia, according to availability. The fuel cell will be tested at the Sustainable Energy catapult centre in Norway before installation one of Odfjell's newest chemical tankers for a trial period. The main partners in the project are Odfjell, Prototech, Wärtsilä and Lundin Energy Norway. Odfjell has leading expertise in global shipping, Prototech in fuel cell technology, Wärtsilä in maritime technology and energy, and Lundin Energy Norway in oil and gas.

"Our tests show a CO<sub>2</sub> reduction of as much as 40-45% when using LNG, compared to current solutions. Increased efficiency and reduced fuel consumption also provide significant cost savings, and the ship will be able to sail significantly longer on the same amount of energy. The system will also be ready to operate completely emission-free from the locations where, for instance, ammonia is available for bunkering," says Bernt Skeie, CEO of Prototech. "The technology also enables direct capture of CO<sub>2</sub>, which will be yet another alternative for emission-free operation when logistics for CO<sub>2</sub> management become available."

"Ships are to be operated for 20-30 years, and we need flexible solutions that can meet future emission requirements. We do not have time to wait, we have to think about zero emissions already now," says Erik Hjortland, Technology Director at Odfjell SE. "The fuel cell project is one of the paths we are pursuing. We focus on machinery rather than focusing on one single type of fuel. Fuel cell technology gives us flexibility that ensures environmentally efficient operation regardless of fuel changes that may occur in the years ahead."

EGYPT

## Feasibility study on new methanol co-production plant

Abu Qir Fertilizers has commissioned a feasibility study regarding the construction of a \$2.6 billion methanol and downstream products plant at its site at Ain Sokhna. The envisaged site would be a 1.6 km<sup>2</sup> plot within the Suez Canal Economic Zone, and the project would be 70% funded through

loans. It would be implemented over two phases, with the \$1.6 billion first phase being an ammonia and methanol co-production facility with a capacity of 400,000 t/a of ammonia and 1.0 million t/a of methanol. The second phase, which will cost an estimated \$1 billion, would add additional downstream production including acetic acid, methanol to olefins, and calcium ammonium nitrate (CAN).

INDIA

## Bids invited for coal-fired methanol plant

State-owned Coal India Ltd (CIL) says that it has invited bids for a coal to methanol plant at the Dankuni Coal Complex in West Bengal, currently run by its subsidiary South Eastern Coalfields Ltd. The tender is being offered on a build-own-operate (BOO) model. A capital outlay of \$800 million is envisaged to build a 676,000 t/a methanol plant. The methanol would then be blended with gasoline at a ratio of up to 15%, in a similar way in which China has extended its own gasoline pool and reduced oil imports by using domestic coal to produce methanol. The plant would supply the methanol requirements of four eastern states of the country - West Bengal, Odisha, Jharkhand and Bihar.

Coal India Ltd says that it would allocate land, power and water to the operator for the proposed plant. It is also in talks with IOCL and other government owned oil companies for a long term methanol offtake agreement. CIL would also supply low-ash high calorific coal from the Ranigunj coalfields, with an ash content of around 24%, providing around 1.5 million t/a of coal. Bids are expected by December 17th.

## Start-up for Trombay methanol plant

Rashtriya Chemicals & Fertilizers has started production at its new methanol plant at Trombay, Mumbai, according to the company. The 242 t/d plant will mean that RCF is no longer dependent on imports for its own requirements, and will also be in a position to satisfy the needs of other methanol consumers in India.

## December commissioning for Namrup methanol

Assam Petrochemicals Ltd says that the methanol reactor has been installed at its Namrup site. State-owned Assam Petrochemicals is building a 500 t/d gas-fed methanol plant at Namrup, and a 200 t/d formaldehyde project at Boitamari, 115 km west of Namrup. Chairman Bikul Ch. Deka said that if everything proceeded according to plan, the methanol plant will be commissioned in December 2020.

VENEZUELA

## Restart at Supermetanol

Pequiven has reportedly restarted its Supermetal plant at Jose in the east of Venezuela. Italy's Eni, a 50% partner in the plant, assisted with bringing the 800,000 t/a plant back online - it had been down since 2Q 2019 and had required repairs to a natural gas line and steam valve.

UNITED STATES

## Hafnia to take methanol from Kalama

Tanker company Hafnia has reportedly agreed to transport up to one third of the output from the proposed Northwest Innovation Works (NWIW) methanol plant at Kalama, Washington state. NWIW

Nitrogen+Syngas 368 | November-December 2020

www.nitrogenandsyngas.com

Nitrogen+Syngas 368 | November-December 2020

CONTENTS

What's in issue 368

COVER FEATURE 1

The future of DME

COVER FEATURE 2

Nitric acid carbon credits

COVER FEATURE 3

Revamping ammonia plants

COVER FEATURE 4

Plant digital solutions

NITROGEN+SYNGAS  
ISSUE 368  
NOVEMBER-DECEMBER 2020

BCInsight

Southbank House, Black Prince Road  
London SE1 7SJ, England  
Tel: +44 (0)20 7793 2567  
Fax: +44 (0)20 7793 2577  
Web: www.bcinsight.com  
www.bcinsightsearch.com

is developing a large scale methanol facility at Kalama with a capacity of up to 3.6 million t/a which aims to export the methanol to China for use in methanol to olefins production. Per the agreement with NIIW, Hafnia will provide and operate purpose-built next-generation methanol dual-fuelled ships to transport one-third of the methanol volume produced by the plant. These vessels will be tied to 19-year charters.

Michael Skov, CEO of Hafnia, is also said to be a proponent of methanol's use as a cleaner shipping fuel. "This initiative is another example of our strategy to support and promote industry decarbonisation while still transporting the resources necessary to sustain the world. We recognise the world is changing, and that the ways we operate and conduct business need to change with it. While there is much uncertainty as to exactly what the future will look like, we're confident that the steps we're taking have Hafnia, our stakeholders and the industry moving in the right direction," said Skov.

The agreement is more good news for NIIW, which tied up a similar deal with Mitsui O.S.K. Lines (MOL) in June 2020. NIIW has had a hard fight with local environmental campaigners to build the plant at Kalama, but has also been buoyed by the submission of a Second Supplemental Environmental Impact Statement (SSEIS) which the Washington state Department of Ecology has said confirms that the project would reduce global greenhouse gas emissions by operating at a lower carbon intensity than comparable coal-based plants in China that it is designed to compete with.

## GERMANY

### A methanol fuel standard for Europe

A German state-funded research project is working to establish the technical basis for standardisation of methanol fuels in Europe. The TEC4FUELS project involves a consortium of universities, research institutes, industrial companies and small and medium-sized enterprises as partners who aim to pave the way for the certification and market launch of methanol fuels. In the short term, the researchers assess the potential for methanol fuels based on renewable hydrogen or other lower carbon technologies to make a significant contribution in reducing CO<sub>2</sub> emissions, in road traffic, as high. However, to achieve this goal, a number of technical requirements must be clarified.

An important aspect is the optimisation of gasoline engine combustion concepts

for the use of methanol. On one hand, the partners are investigating the suitability of 15% methanol as a drop-in fuel to conventional gasoline in future series-produced gasoline engines and, on the other hand, the use of 100% methanol in a technically adapted prototype engine to be used in a vehicle. Among other things, the focus is on questions of cold-start behaviour, knock resistance, efficiency, exhaust emissions, and material compatibility.

### Siemens to build green hydrogen plant

Siemens has revealed plans to build a 900 t/a green hydrogen plant at the Wunsiedel Energy Park in the north of Bavaria, with the aim of eventually expanding this to 2,000 t/a. The plant will run solely on renewable energy. Ground breaking for the first phase is scheduled for the end of 2020 and commissioning at the end of 2021. The hydrogen will be used to fill gas cylinders for local distribution and shipped by truck to local and regional end customers, mostly in Upper Franconia, the Upper Palatinate, southern Thuringia and Saxony, as well as the Czech Republic. Siemens said a public hydrogen filling station for trucks and buses may be added later at the same location to aid the conversion of heavy-duty traffic and public transportation to CO<sub>2</sub>-free drive technology.

### 'Artificial photosynthesis' pilot plant

Siemens has also commissioned a pilot plant, in conjunction with Evonik and money from the German Federal Ministry of Education and Research (BMBF) that uses carbon dioxide and water to produce chemicals. The energy is supplied by electricity from renewable sources. The pilot plant is located in Marl, in the northern Ruhr area, and forms part of the €6.3 million Rheticus

I and II research projects.

The process, described as 'artificial photosynthesis', electrolyses carbon dioxide and water to generate a syngas consisting of CO and H<sub>2</sub>. The syngas is then used in a bioreactor developed by Evonik to feed bacteria which produce specialty chemicals, initially for research purposes. Over the coming weeks, the composition of the syngas and the interaction between electrolysis and fermentation will be optimised, and a unit for processing the liquid from the bioreactor will be set up to obtain the pure chemicals.

## TRINIDAD & TOBAGO

### CGCL loads first methanol shipment

Caribbean Gas Chemical Ltd (CGCL) says that it has loaded its first cargo of methanol from its new \$900 million methanol and dimethyl ether (DME) facility at La Brea. In a press statement, CGCL said that 13,000 tonnes of methanol were loaded on board the M/T Trans Catalonia at the Port of Brighton La Brea.

Methanol and ammonia production on Trinidad has suffered from gas pricing and availability and low product prices in recent years, but CGCL, which is part owned by the National Gas Corporation of Trinidad and Tobago (NGC), is said to have benefited from favourable gas prices. The CGCL consortium also includes Mitsubishi Gas Chemical Company, Inc., Mitsubishi Corporation, Mitsubishi Heavy Industries, Engineering Ltd, and Massy Holdings Ltd.

The CGCL plant has the capacity to produce 1.0 million t/a of methanol and 20,000 t/a of DME. Construction began in 2015 but completion has been delayed from the planned start-up date and the plant was only finished in June this year.



The CGCL site at La Brea, Trinidad.

PHOTO: CGCL

## People

The UK Agricultural Industries Confederation has announced that **Sam Bell**, UK Commercial Director at CF Industries and **Nick Major**, Corporate Affairs Director at ForFarmers have taken over as chairs for the AIC's Fertiliser Executive Committee and Feed Executive Committee, respectively.

Commenting on Sam's appointment, Jo Gilbertson, Fertiliser Sector head for the AIC said: "Sam's appointment comes at a critical time for the sector and we are delighted that she has accepted the role. I am confident that Sam will build on the excellent work that Peter Scott Technical Director Origin Fertilisers, has driven over the last two years. The sector will not be losing Peter's expertise as he has recently been appointed Chair of the European Fertiliser Blenders' Association (EFBA). Sam will be taking up her role on the 28th October".

Sam's stated objective is to ensure that the fertiliser sector navigates the right path through all the forthcoming changes in a post-Brexit landscape. She said: "Significant change is on the horizon and we need to respond with creativity, diligence and energy to provide solutions to achieve a productive, sustainable future for UK agriculture. I need to ensure time and resources are well spent, engagement from members is high and we effectively communicate to all stakeholders to deliver our agreed goals".

For the Feed Executive Committee, Nick Major was appointed at the AIC AGM in early October, taking over from recently appointed AIC Chair Angela Booth, Director of Feed Safety at AB Agri.

"We are delighted that Nick has accepted this role having served as a member of the Feed Executive Committee for many years", commented James McCulloch, Feed Sector head for the AIC. "He has already had an integral role in the initiatives championed by Angela during her 8 years as Chair and I am confident that he will be bringing his experience, most notably as immediate Past-President of FEFAC to build on the unwavering commitment that Angela has demonstrated during her time". On behalf of the whole committee I would like to thank Angela and look forward to working with her in her role as AIC Chair.

AIC has also appointed **Ed Barker** to the role of Head of Policy & External Affairs. Barker is from a Suffolk farming background, with stints at Westminster, the CLA and most recently as senior policy advisor for the National Pig Association. Chief Executive Robert Sheasby emphasised there was much to do, "we are at a critical stage in trade negotiations with our biggest trading partner and with many others who will become increasingly influential. Our sector is facing significant change as the Common Agricultural Policy makes way for a devolved approach. I am confident that Ed will help AIC develop policy alongside members which will ensure we move forward in a positive way."

ClimeCo says that it has promoted Dr. **Scott Subler** to Chief Science Officer (CSO). Subler has made an enduring mark on the carbon offset world over the last 15 years. From overseeing the first US offset

delivery from a dairy farm methane capture project to chairing the Offsets Committee for the Chicago Climate Exchange, Subler has been a major influence on many carbon offset methodologies that are used today. His work investigating different types of lagoon cover systems for dairy and swine farms in different climates continues to impact new methane capture installations, and his advocacy for organic waste composting projects resulted in the protocol used today at the Climate Action Reserve.

**Nirlep Singh Rai** will become the new Director (Technical) of India's National Fertilizer Ltd (NFL). Rai previously served as an executive director in the same organisation. He is also chief executive officer (CEO) of Ramagundam Fertilizers and Chemicals Ltd (RFCL), a joint venture between NFL, Engineers India Limited (EIL) and Fertilizer Corporation of India Limited (FCIL).

Rai gained a Bachelor of Engineering (Instrumentation and Control) from Thapar University, and has 35 years of professional experience. He took charge of RFCL on November 1, 2018. He has worked at NFL in various capacities, including head of technical services and projects at the Bathinda unit. Rai has been involved in various projects such as feed stock change over from fuel oil to natural gas, commissioning of DCS and ESD systems, machine monitoring systems, process gas analysers, fire and gas systems etc. His experience includes technical services and operation and maintenance of large scale fertilizer plants.

## Calendar 2021

### FEBRUARY

16-18

Nitrogen+Syngas USA, TULSA, Oklahoma, USA  
Contact: CRU Events, Chancery House, 53-64 Chancery Lane, London WC2A 1QS, UK.  
Tel: +44 (0) 20 7903 2444  
Fax: +44 (0) 20 7903 2172  
Email: conferences@crugroup.com

27-29

4th International Fertilizers Conference: Eastern Europe, Baltic States & Balkans, BUDAPEST, Hungary  
Contact: WFM Chem-Courier agency  
Tel: +38 056 370 12 04  
Email: conf@wfmesteurope.com

### MARCH

Date T.B.C.

Argus Asia Fertilizer, location T.B.C.  
Contact: Argus Media  
Tel: +44 (0) 20 7780 4340  
Email: conferences@argusmedia.com

1-3

Nitrogen+Syngas 2021, ROME, Italy  
Contact: CRU Events  
Tel: +44 (0) 20 7903 2444  
Fax: +44 (0) 20 7903 2172  
Email: conferences@crugroup.com

### APRIL

26-28

Syngas 2021, BATON ROUGE, Louisiana, USA

**!** The following events may be subject to postponement or cancellation due to the global coronavirus pandemic. Please check the status of individual events with organisers.

Contact: Betty Helm, Syngas Association  
Tel: +1 225 706 8403  
Web: www.syngasassociation.com

31-MAY 2

IFA 88th Annual Conference, NEW DELHI, India  
Contact: IFA Conference Service  
Tel: +33 1 53 93 05 00  
Email: ifa@fertilizer.org

### MAY

18-19

IFS Technical Conference, AMSTERDAM, Netherlands  
Contact: International Fertiliser Society  
Tel: +44 (0)1206 851 819  
Email: secretary@fertiliser-society.org

## CONTENTS

What's in issue 368

## COVER FEATURE 1

The future of DME

## COVER FEATURE 2

Nitric acid carbon credits

## COVER FEATURE 3

Revamping ammonia plants

## COVER FEATURE 4

Plant digital solutions

NITROGEN+SYNGAS  
**ISSUE 368**  
NOVEMBER-DECEMBER 2020

**BCInsight**

Southbank House, Black Prince Road  
London SE1 7SJ, England  
Tel: +44 (0)20 7793 2567  
Fax: +44 (0)20 7793 2577  
Web: www.bcinsight.com  
www.bcinsightsearch.com



# Plant Manager+

## Incident No. 3 Backflow in pressurised leak detection system for loose liner of HP scrubber

This case study describes a backflow scenario in a pressurised leak detection system. Backflow can occur in case of a relatively large leak (crack in liner), where the flowmeter installed downstream of the equipment acts as a flow restriction, allowing pressure to build up.

If the flowmeter is installed upstream of the equipment there is the risk of disconnected tubing going undetected.

Furthermore, in this case the process fluid did not contain urea and is

less sensitive to clogging, even though it did. In cases where the process fluid contains urea the situation is even more critical.

From this incident it can be learned that a pressurised leak detection system requires tracing and insulation of all tubing in the leak detection circuits. However, this will only temporarily reduced the risk of clogging. In the opinion of the FIORDA team, an active vacuum leak detection system is a more reliable choice.



Carbamate in tubing of leak detection circuit due to backflow.

Fig. 1: Leak in pressurised leak detection system

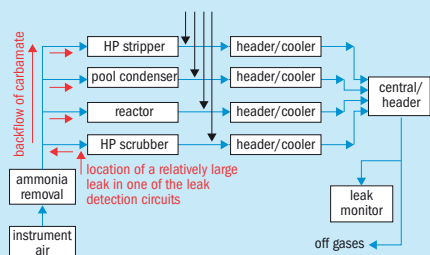

Source: FIORDA

### Event description

In 2010, a 25-22-2 urea grade liner was installed on a 316L UG older overlay weld in the bottom of a HP scrubber dating from 1980. As the ammonia analyser was unavailable due to maintenance, the outlet vent of the pressurised leak detection system was checked for ammonia with a pocket ammonia analyser every four hours.

On one occasion, ammonia was detected and further investigation revealed that a lot of tubing had been clogged (see Fig. 1 and photo above). After opening the HP scrubber it was revealed that the liner showed cracks.

### Immediate response action

The plant was stopped for further inspections. By analysing the tubing with more carbamate, it was concluded that backflow had occurred and contaminated the leak detection circuits of all three HP equipment items.

This case study report is one of many serious incident reports on UreaKnowHow.com's Fertilizer Industry Operational Risks Database, FIORDA, which has been created for collecting and sharing process safety and reliability information among participating companies in the fertilizer industry.

### Causes

The leak rate was so large that the flowmeter acted as a flow restriction, pressure built up and backflow occurred leading to clogging of the leak detection circuits in all of the other high pressure equipment items.

### Primary consequence

As a result of the timely shutdown the risk of a rupture was successfully avoided.

### Secondary consequence

There was an unplanned shutdown, extensive work was required to clean and open all leak detection circuits and carry out a repair/relining job.

### Risk level

The likelihood of a major consequence was moderate, but the risk level was high.

### Prevention safeguards

Assure proper functioning of your leak detection system. Safe plant operation is only possible with a good working leak detection system, including an accurate and reliable ammonia analyser.

### Mitigation safeguards

In case of a leak, confirm and locate the leak, shut down the plant and drain the synthesis section as soon as possible.

### Corrective recommendation

The leak detection system was refurbished and made operational before start-up of the plant. All plant operators received renewed instructions. An inspection and maintenance program was also implemented to increase the reliability and availability of the existing leak detection system.



## Refining — Precious Metals — Recycling

- ◆ Non-Destructive Cleaning
- ◆ Destructive PGM Recovery
- ◆ Filters and Sludge PGM Recovery
- ◆ Precious Metals Refining



1647 Wheatland Center Rd.  
 Scottsville, NY 14546, USA  
 Contact: [betsyg@sabinmetal.com](mailto:betsyg@sabinmetal.com)  
 Visit us at <https://sabinmetal.com/>

### CONTENTS

What's in issue 368

### COVER FEATURE 1

The future of DME

### COVER FEATURE 2

Nitric acid carbon credits

### COVER FEATURE 3

Revamping ammonia plants

### COVER FEATURE 4

Plant digital solutions

NITROGEN+SYNGAS  
**ISSUE 368**  
 NOVEMBER-DECEMBER 2020

**BCInsight**

Southbank House, Black Prince Road  
 London SE1 7SJ, England  
 Tel: +44 (0)20 7793 2567  
 Fax: +44 (0)20 7793 2577  
 Web: [www.bcinsight.com](http://www.bcinsight.com)  
[www.bcinsightsearch.com](http://www.bcinsightsearch.com)

# Tackling emissions in the nitric acid industry

The new 1,500 t/d Navoiazot nitric acid plant, Uzbekistan.

PHOTO: CASALE

Malte Plewa, Volker Schmidt, Daniel Ávila and Enrico Rubertus of German development agency GIZ and Dr. Silke Karcher of the German Environment Ministry (BMU) discuss action on climate change from nitric acid production and the Nitric Acid Climate Action Group (NACAG) and its global initiative for mitigating emissions.

It is undeniable that climate change is one of today's greatest challenges. Greenhouse gas (GHG) emissions are responsible for altering climate patterns and increasing global temperatures. The fertiliser industry is a major source of greenhouse gas emissions around the world. The application and use of synthetic fertilisers account for most of the sector's emissions, but the ammonia and nitric acid production processes are also major contributors.

Nitric acid is a nitrogen compound used throughout the world as a raw material in fertiliser manufacturing. Nitrous oxide (N<sub>2</sub>O) is an unwanted by-product of the production process and a potent ozone-depleting greenhouse gas (GHG) with a global warming potential 265 times that of CO<sub>2</sub>. Even though extensive abatement is neither technically difficult nor expensive, this harmful greenhouse gas is released into the atmosphere unabated by most production facilities around the world. The respective abatement technology is consequently currently applied in the European Union (EU), where its operation is highly

incentivised by the European Emissions Trading System (EU-ETS). Outside the EU, however, only a few countries or regions have implemented similar incentive systems, often with a limited reach. In addition, there are a small number of nitric acid plants that continue to operate N<sub>2</sub>O abatement technology because they still hold valid contracts for selling emission reduction certificates through the UN Clean Development Mechanism (CDM), either through individual purchase agreements or option rights from the last auction of the Pilot Auction Facility (PAF).

Based on the available information, it is estimated that the operation of dedicated N<sub>2</sub>O abatement technology is limited to around 25% of the approximately 580 nitric acid plants that exist worldwide. This is especially alarming as N<sub>2</sub>O abatement in nitric acid production has been rather successful under the CDM. To date, project activities in nitric acid production facilities have generated emission reduction certificates worth more than 92 million tonnes of CO<sub>2</sub> equivalent. In total, almost 100 CDM projects have been registered. However, due

to the drastic drop in certificate prices at the end of 2012, approximately 40 of these projects never actually reached technical implementation and most of the rest were decommissioned in the years that followed.

While GHG mitigation can be challenging or expensive in many sectors, proven N<sub>2</sub>O abatement technology for nitric acid installations is readily available and mitigation is possible at a comparatively low cost of approximately \$1.00 – 5.00/tonne of CO<sub>2</sub> equivalent. Moreover, the technology can be installed in existing plants relatively easily and can reach very high abatement efficiencies of up to 98%. Estimates suggest that there is a theoretical additional abatement potential of up to 180 million tonnes of CO<sub>2</sub> eq per year globally. Given the ongoing challenges of climate change, we are duty bound to exploit this cost-effective mitigation potential.

## NACAG's launch and offer

Driven by this rationale, the German Federal Ministry for the Environment, Nature Conservation and Nuclear Safety (BMU)

launched the Nitric Acid Climate Action Group at UNFCCC's 21st Conference of the Parties in Paris (COP 21). This global action group's ambitious vision is for all nitric acid production plants worldwide to implement and permanently operate effective N<sub>2</sub>O abatement measures; in other words, transform the entire industry sector towards climate-friendly production.

To achieve this goal, NACAG supports its partner countries in the technical aspects as well as in designing effective policies to ensure the permanent abatement of these emissions. For example, NACAG conducts technical studies at plant level on the most suitable mitigation technology; it also provides policy advisory services by analysing potential options for regulation of N<sub>2</sub>O abatement in its partner countries.

In addition, NACAG offers financial support for N<sub>2</sub>O abatement measures to plant operators in countries which do not have sufficient resources to implement these activities. There are approximately 95 nitric acid plants located in countries eligible to receive official development assistance, with a total annual abatement potential of roughly 45 million tonnes CO<sub>2</sub> eq.

The financial support is provided through two different mechanisms. For plant operators which have not operated N<sub>2</sub>O abatement technology in recent years, NACAG provides direct grants to purchase and install nitrous oxide abatement technology and emission monitoring equipment.

Plant operators can apply for a grant to the NACAG Secretariat directly by filling in an application form. The NACAG Secretariat will review the application on eligibility criteria and perform a due diligence assessment of the plant. If the outcome is positive, an agreement is drawn up between the plant operator and the NACAG Secretariat. The grant is non-repayable and covers all costs related to the purchase and installation of the abatement technology.

For plant operators which have recently mitigated production-related N<sub>2</sub>O emissions, usually incentivised by the CDM, NACAG offers participation in a climate auction for price guarantees on emission reduction certificates. This second financing programme is based on the World Bank's Pilot Auction Facility and operates under the Nitric Acid Climate Auctions Programme (NACAP).

In this climate auction, a price guarantee in the form of bonds for future independently verified emission reductions is sold to private companies and individuals; the

value of these price guarantees is determined by an auction. Under the Nitric Acid Climate Auctions Programme, the auctions sell bonds that may be redeemed after the bondholder delivers verified eligible N<sub>2</sub>O emission reductions from nitric acid plants. The NACAP will make the payments in exchange for eligible carbon credits generated from 2018 to 2024, with the last payment occurring in 2025.

## Financial support linked to partner country commitment

All countries worldwide are invited to join the NACAG by signing the NACAG Declaration, a non-binding expression of support for the action group's goals. To qualify for NACAG funding, the partner countries need to formally commit to implementing effective policy measures that guarantee a commitment to N<sub>2</sub>O abatement in nitric acid production after 2023. This strategy is in line with the spirit of the Paris Agreement as it not only ensures the lasting effectiveness of the measures but also invites all countries to count this easily tapped potential towards their own Nationally Determined Contributions (NDCs) to the Paris Agreement, thus contributing to raising the ambition. From the perspective of the partner countries, it makes sense to use these 'low-hanging fruit' emission reductions for their own climate commitments, rather than for any form of international trading of mitigation outcomes through existing schemes or possible future set-ups under Article 6 of the Paris Agreement.

This firm commitment is expressed by the government of the partner country signing a unilateral Statement of Undertaking (SoU), which ensures that a one-time investment is turned into permanent mitigation. Since this requires an official agreement from the partner countries' governments, it can entail a lengthy political process.

The initiative has been in close discussions with more than 30 countries to offer technical and financial support. So far, 14 countries have joined by signing the Declaration, thereby expressing support for the initiative's goals. Moreover, four countries (Georgia, Mexico, Tunisia and Zimbabwe) have already signed the formal political commitment (SoU) and thus qualify for financial support. NACAG is currently setting up grant agreements with the local nitric acid producers in these countries. It is expected that more countries will sign the SoU in the coming months.

## A regulatory deficit

Despite the availability of proven and cost-effective N<sub>2</sub>O abatement technology, only a few countries have implemented policies on the abatement of N<sub>2</sub>O emissions in nitric acid production. There are several reasons for this regulatory deficit. In developing countries in particular, fertiliser producers are often considered to be of strategic importance for food security, the regulators therefore hesitate to enforce stricter environmental regulations. Furthermore, in most countries, there are only a very small number of these facilities; creating a separate regulation aimed solely at this sector may therefore appear somewhat arbitrary.

However, in working towards the Paris Agreement's goals to keep global warming well below 2°C, it is now impossible to ignore a sector that generates considerable amounts of GHG emissions when they can easily be mitigated at a comparatively low cost. There are positive signs from a variety of partner countries worldwide that production-related N<sub>2</sub>O emissions from the nitric acid sector will be considered in the current updating process of the NDCs, due at the end of 2020. Once included in the NDC, these emissions will need to be covered by some sort of policy to ensure that they are permanently abated.

## Outlook

While countries are preparing their successive NDCs to the Paris Agreement, for many countries the inclusion of the nitric acid production sector will present an opportunity to raise their climate ambitions. The NACAG initiative offers technical and financial support, linked to a firm partner country commitment, to incentivise the early realisation of this substantial global mitigation potential.

With 14 member states (as at July 2020) already, the NACAG initiative has proven to be of interest to governments and plant operators around the world. Other countries are invited to join the action group to show their support for the initiative's goal to phase out N<sub>2</sub>O emissions from nitric acid production globally. Plant operators interested in climate action are also welcome to contact the NACAG Secretariat. As the NACAG approach has been well received internationally, it would be interesting to see whether this approach can be expanded to other sectors besides nitric acid production.

Further information: [www.nitricacidaction.org](http://www.nitricacidaction.org)

CONTENTS

What's in issue 368

COVER FEATURE 1

The future of DME

COVER FEATURE 2

Nitric acid carbon credits

COVER FEATURE 3

Revamping ammonia plants

COVER FEATURE 4

Plant digital solutions

NITROGEN+SYNGAS  
ISSUE 368  
NOVEMBER-DECEMBER 2020

BCInsight

Southbank House, Black Prince Road  
London SE1 7SJ, England

Tel: +44 (0)20 7793 2567

Fax: +44 (0)20 7793 2577

Web: [www.bcinsight.com](http://www.bcinsight.com)  
[www.bcinsightsearch.com](http://www.bcinsightsearch.com)



PHOTO: BUNDESREGIERUNG/SANDRA STEINS

**Jochen Flasbarth**, German State Secretary for the Environment, Nature Conservation and Nuclear Safety (BMU), talks to *Nitrogen+Syngas* about the Nitric Acid Climate Action Group.

“It is our goal to support the partner countries throughout the entire process of sustainably transforming the nitric acid sector.”

**Mr Flasbarth, could you please explain the rationale behind the launch of the Nitric Acid Climate Action Group and its link to the Paris Agreement?**

The Paris Agreement marks a major paradigm shift in international climate policy. For the first time, all member states committed to set their own emissions targets and regularly review them to be more ambitious. With the Nitric Acid Climate Action Group, BMU launched an initiative which follows the spirit of the Paris Agreement, providing climate finance and technical support to developing countries for realising the cost-effective mitigation potential of the nitric acid sector. The Action Group therefore contributes to raising ambitions by encouraging the partner countries to include the nitric acid sector in their Nationally Determined Contributions (NDCs) to the Paris Agreement.

A key element of NACAG is that the partner countries need to commit to ensuring that the emissions from the sector will be mitigated permanently. NACAG only provides financial support to countries which have made this firm commitment.

**Why does the initiative target the nitric acid sector globally?**

The intention was to pick a sector where the abatement of emissions is particularly cost-effective, and for which widely proven mitigation technologies are available. The global mitigation potential in this sector is substantial as nitrous oxide has a global warming potential of 265 relative to CO<sub>2</sub> and, in some countries, emissions from nitric acid production account for a considerable share of total national emissions. Therefore, in working towards the Paris Agreement goals, this sector cannot be ignored. NACAG promotes the early achievement of this potential within national mitigation strategies, the raising of ambitions and the updating of NDCs.

Under the Clean Development Mechanism, plant operators from developing countries were given an incentive to mitigate emissions and monetise the resulting emission reductions. How-

ever, when the price for these credits dropped, we observed that the mitigation activities in some countries stopped and that many plant operators uninstalled the technology to save on maintenance costs, leading to a rise in emissions. Through NACAG, we aim to revive these abatement activities on a global scale. We would also create an incentive for the plant operators which have not been active under the CDM to begin to address these emissions and to encourage governments to regulate emissions nationally and include them in the NDCs. Hence, the NACAG can serve as an example of how mitigation measures, which previously took place under the CDM, can be transferred into countries' NDCs and therefore be part of a long-term sustainable solution.

**What are the innovative aspects and what made this approach unique when it was launched at the COP in Paris?**

To achieve the goals of the Paris Agreement any new initiative needs to have a strong focus on concrete implementation leading to measurable results. However, capacity building and the transfer of technology and knowledge are also important factors. The NACAG initiative combines all of these to reach its vision and goals.

Providing grant-based finance for companies to purchase mitigation and monitoring technology conditioned on a long-term political commitment was innovative. The initiative also offers a market and results-based financing option with the Nitric Acid Climate Auction Program. NACAG's aim is for all nitric acid plants worldwide to operate with effective N<sub>2</sub>O abatement technology thus contributing towards transforming this industrial sector globally and creating a level playing field on a global scale.

**From a pure business perspective, plant operators do not have an incentive to abate the N<sub>2</sub>O emissions from nitric acid production. How can it be ensured that the emission reductions achieved through NACAG will be permanent?**

NACAG links direct financial support with the partner countries' long-term political commitment to greenhouse gas mitigation in this sector. The key criterion for gaining access to NACAG's financial support is that countries where the supported nitric acid plants are located must confirm that they will implement suitable measures to ensure that the emission reduction activities continue after the initiative's support has ended. This can for example be achieved through market-based approaches, such as an emissions trading scheme operating in the European Union but also through direct regulation via emission limits. We see different approaches being evaluated and implemented in a variety of countries. We support partner governments in the design of instruments to measure N<sub>2</sub>O emissions and regulate their abatement as well as on ways of including the nitric acid sector in the countries' NDCs.

**How do governments and industry react to NACAG's offer?**

Since NACAG was launched in 2015, there have been discussions with around 30 countries, namely those which produce nitric acid and are eligible to receive official development assistance. So far, thirteen countries have joined the action group by signing a Declaration of Support.

Throughout the work on NACAG, we have received positive signals from both the industry and governments in many countries. The governments understand and embrace the opportunity to use NACAG's offer to raise their ambitions under the current NDC revision process and nitric acid producers often welcome the offer of technical and financial support. Several plant operators have proactively contacted NACAG to engage in emission reduction activities. We are also regularly invited to speak about NACAG at major industry events. These are signs that industrial companies are increasingly aware of their responsibility and the importance of addressing climate change.

**Could you tell us a bit more about how NACAG operates and what has been achieved so far?**

In my opinion, a key success factor is the continuous dialogue between all relevant stakeholders, especially partner governments and plant operators. In addition to making financial resources available, NACAG advises its partners on a technical level. It is our goal to support the partner countries throughout the entire process of sustainably transforming the nitric acid sector.

We have conducted more than 30 workshops, performed numerous technical feasibility studies at plant level and advised partner countries on adequate policy instruments through country-specific studies. In some countries, for example Tunisia and Zimbabwe, we are in the final stages of a grant agreement for the implementation of N<sub>2</sub>O abatement activity, and other countries such as Mexico and Georgia have made good progress towards the same goal.

**NACAG started as a pilot initiative in the nitric acid sector. Would you say that the NACAG approach could be replicated in other sectors? If so, which sectors could these be?**

I would like to highlight that the nitric acid sector was selected as several characteristics make it particularly favourable for a global action group approach such as NACAG. The main aspects being that proven mitigation technology is readily available and easy to install resulting in a high yield of emission reductions per individual measure at comparatively low mitigation costs per tonne of CO<sub>2</sub> equivalent. Another important aspect is the limited number of stakeholders involved, which makes it possible to provide individual technical advice and financial support.

The NACAG approach combines financial and technological support with a long-term commitment from the participating countries. While it may be difficult to find a set-up as distinct as the nitric acid sector in any other industry, the NACAG approach, or a very similar approach, can generally be applied to sectors that also meet or come close to meeting these characteristics. One example could possibly be seen in caprolactam production facilities which, like nitric acid plants, generate N<sub>2</sub>O as a by-product and where the same abatement technologies could be applied. A similar approach could also be used in large municipal landfills that have poor or non-existent waste management systems and produce high levels of methane. ■

# BORSIG

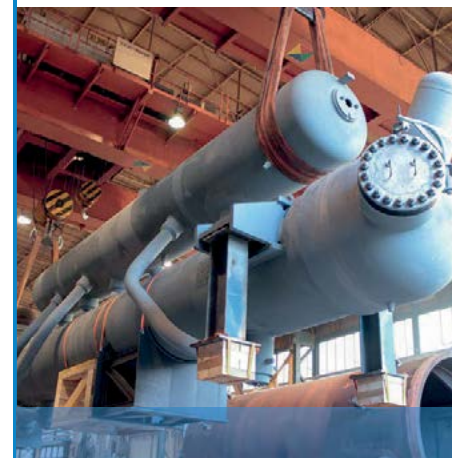

➤ WASTE HEAT RECOVERY SYSTEMS

➤ WASTE HEAT BOILERS FOR AMMONIA PLANTS

➤ SYNLOOP WASTE HEAT BOILERS FOR AMMONIA PLANTS

➤ SYNTHESIS GAS COOLERS DOWNSTREAM OF PARTIAL OXIDATION OF OIL OR NATURAL GAS

[www.borsig.de/pro](http://www.borsig.de/pro)

BORSIG Process Heat Exchanger GmbH

Phone: +49 (0)30 4301-01

Fax: +49 (0)30 4301-2447

E-mail: [info@pro.borsig.de](mailto:info@pro.borsig.de)

Egellsstrasse 21, 13507 Berlin

Germany



CONTENTS

What's in issue 368

COVER FEATURE 1

The future of DME

COVER FEATURE 2

Nitric acid carbon credits

COVER FEATURE 3

Revamping ammonia plants

COVER FEATURE 4

Plant digital solutions

NITROGEN+SYNGAS  
**ISSUE 368**  
NOVEMBER-DECEMBER 2020

**BCInsight**

Southbank House, Black Prince Road  
London SE1 7SJ, England

Tel: +44 (0)20 7793 2567

Fax: +44 (0)20 7793 2577

Web: [www.bcinsight.com](http://www.bcinsight.com)  
[www.bcinsightsearch.com](http://www.bcinsightsearch.com)

# The future of DME

PHOTO: SHCHEKINOAZOT

A few years ago DME production from methanol gave a major boost to world methanol demand, with DME being used as a blendstock for LPG. However, demand plateaued and DME has not had the takeoff that its proponents feel it should have. Could new renewable DME processes give it the boost it needs?

Fig. 1: Development of Chinese DME capacity and production

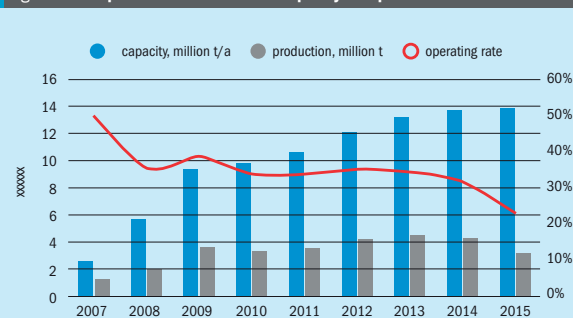

Source: CCF Group

Left: The new Shchekinoazot DME plant in Russia, completed in 2019.

Until the mid-2000s, dimethyl ether (DME) was essentially a very minor methanol derivative used primarily as a CFC-free aerosol propellant, with a total global market size of around 1.6 million t/a. However, from about 2005, falling costs of methanol production led to interest growing in its potential use as an alternative fuel.

DME's fuel uses are essentially threefold: as a substitute for liquid petroleum gas (LPG) in domestic cooking and heating; as a substitute for diesel in car, truck and ship engines; and as a fuel for power plants. Initially, particularly in China, DME demand began to take off in the 2000s as a blendstock for LPG. DME made from coal-derived methanol was seen by the Chinese authorities as a way, along with direct methanol fuel blending into gasoline, of reducing China's dependence on imported oil and petroleum products by using domestic coal reserves.

## LPG

DME has similar properties to LPG, and can be blended at ratios of up to 10-20% in LPG without requiring any change in storage and distribution infrastructure. China is a major user of LPG and also a considerable importer, and coal-derived DME could be made cheaper than imported LPG. As a result,

DME capacity growth in China was phenomenal, from just 120,000 t/a in 2005 to 9 million t/a in 2010 and around 14 million t/a in 2015. However, as Figure 1 shows, such over-optimistic building of DME capacity ran far ahead of demand, and by 2013, DME consumption in China had reached only 4 million t/a, and utilisation rates were down to 30%.

There were various reasons for this. China's National Development and Reform Committee (NDRC) concluded in a report in 2010 that downstream methanol uses like DME had been used as a justification for companies to privately 'acquire' access to coal resources (which were at the time otherwise treated as state assets). There was also a lack of national standards, and a great deal of illegal over-blending of DME in LPG. At too high a level, DME can corrode rubber seals. This led to leaks of LPG and consequent explosions, leading to a regulatory crackdown from 2010 onwards. A contribu-

tory factor was falling demand for LPG itself as more cities in China were brought onto the national natural gas network, as well as increased domestic production of LPG from a myriad of new domestic refineries.

More recently, Chinese methanol producers have found that they can achieve greater profits from selling into the burgeoning methanol to olefins (MTO) market, and interest in DME has waned.

The result has been that while China remains the main market for DME at present, with around 70% of global demand (90% of which is used as an LNG extender), it has not so far caught on in any major way outside China.

## Indonesia

The at least partial success of China's LPG substitution programme did lead to interest in other countries that are large users of LPG, such as Brazil, Iran, India, Nigeria, South Korea, Indonesia, and Egypt, in potentially doing the same thing. For some years Iran has had plans to build a large scale (200,000 t/a) DME plant, and a few years ago Egypt likewise explored the feasibility of building such a plant. Kogas designed a 300,000 t/a plant for Saudi Arabia but the project did not secure a gas allocation. Indeed, outside of a few up-ratings of capacity (eg at Akzo Nobel's site in Rotterdam), a 20,000 t/a plant at Shchekinoazot in Russia for aerosol production, and the new 20,000 t/a Caribbean Gas Chemical Company side-stream on Trinidad, actual new DME capacity building has been thin on the ground.

However, Indonesia now appears to be making a concerted effort to follow the Chinese route and use domestic coal to produce methanol-based DME, with the aim of using it as an LPG blendstock. Indonesia is the fourth largest LPG importer in Asia (after China, Japan and India), and rapidly increasing consumption of LPG combined with the increasing burden of domestic subsidies for the product and diminishing production has led to the project. Indonesia's consumption of LPG has increased from 1 million t/a to 7.6 million t/a in 2019, 75% of which is now imported.

State oil company Pertamina is now partnering coal mining company PT Bukit Asam and technology supplier Air Products and Chemicals to develop a large scale coal gasification facility which will produce DME and other downstream products for domestic consumption. The agreement

follows a feasibility study conducted from 2018 by Pertamina which included an implementation roadmap and market demonstration of DME for use as a cooking fuel in the country. The plant is to be sited at Peranap in Riau Province on Sumatra, using coal from Bukit Asam's nearby mine, and will aim to produce up to 1.4 million t/a of DME, together with 300,000 t/a of surplus methanol and 250,000 t/a of mono ethylene glycol. Front end engineering design began in February 2020, with construction work expected to be completed in 2024-25.

## Vehicle fuel

As well as a blendstock for LPG, DME can also be used as a substitute for diesel fuel in vehicle engines. DME's high cetane number delivers performance and efficiency comparable to diesel, and compared to compressed gases it has sufficient energy density (about 55% of that of diesel) to support long range transport. Like diesel, it ignites on compression and requires no separate ignition mechanism, and unlike LNG, it does not require cryogenic storage temperatures; it is handled



## Maximize SMR Performance with the Powerhouse Partnership of Blasch StaBlox™ and BD Energy Systems' TOP™ Technology

With Blasch StaBlox Reformer Flue Gas Tunnel System and BD Energy Systems' patented Tunnel Optimal Performance (TOP) Technology, you can expect:

- Improved temperature uniformity that can significantly increase output with less risk to catalyst tubes
- Reduced pressure drop saves energy
- Significantly faster installation time can shorten outages
- Stable design eliminates need for buttresses and can allow for wider tunnels

580 Broadway | Albany, NY 12204 | 518-436-1263 | www.blaschceramics.com

## CONTENTS

What's in issue 368

## COVER FEATURE 1

The future of DME

## COVER FEATURE 2

Nitric acid carbon credits

## COVER FEATURE 3

Revamping ammonia plants

## COVER FEATURE 4

Plant digital solutions

NITROGEN+SYNGAS  
**ISSUE 368**  
NOVEMBER-DECEMBER 2020

**BCInsight**

Southbank House, Black Prince Road  
London SE1 7SJ, England

Tel: +44 (0)20 7793 2567

Fax: +44 (0)20 7793 2577

Web: www.bcinsight.com  
www.bcinsightsearch.com

and stored like propane, with tank pressures of only 75 psi (vs. 3,600 psi for CNG), meaning it can safely be stored on-site. Because DME contains no carbon-carbon bonds, it produces no soot, so no diesel particulate filter is necessary, which leads to weight savings, and because of the lack of cryogenic storage as compared to LNG or CNG, DME tanks can considerably lighter and considerably less complex.

The downside is that, as with LPG, use of DME does require a specially constructed engine, using higher fuel injection rates and fewer plastic components that might be corroded. Nevertheless, major commercial vehicle manufacturer Volvo became interested in DME's potential as a vehicle fuel, and the company was able to adapt one of its existing diesel engines for DME use. The company supplied DME-adapted trucks as part of a European Union funded 'bio-DME' project in Sweden, which gasified a waste stream from a paper mill to produce small quantities (10 t/d) of methanol and DME using Haldor Topsoe technology. The DME production was trialed from 2011-12 in a fleet of 10 Volvo trucks, and the project was deemed a technical success, prompting further development work by Volvo, although the pilot bio-DME site was actually closed down in 2016 after operating at a financial loss.

Volvo's interest moved on to California. In 2013, alternative fuel developer Oberon Fuels began operations at a pilot DME plant in southern California, using natural gas as a feedstock in a small scale (3,700 t/a) modular plant to produce DME, and the same year Volvo signed a partnership agreement to provide DME-powered trucks to demonstrate DME's potential as an alternative fuel. Progress has been slow but steady, and other US companies have begun to come on board. Mack has been demonstrating a DME-powered truck, and Ford has worked on a DME-powered passenger car. In China, there has also been work on DME commercial vehicles, including prototype garbage trucks and street sweepers.

Oberon Fuels meanwhile have concentrated – in collaboration with STV Energy – on switching to biogas as a feedstock in order to meet Californian renewable fuel mandates, and in September California's legislature voted to reduce taxes on renewable DME to the same level as other alternative fuels.

## Maritime fuel

There has also been some interest in DME as a clean burning fuel for ships, prompted in part by the new more stringent SO<sub>2</sub> emission limits mandated by the International Maritime Organisation (IMO) from January 2020. The move has led shipowners to consider a variety of different alternative fuels, including natural gas, methanol and DME. The 'Spireth' (Spirits and Ethers as Marine Fuel) project ran from 2012-14, testing a mix of methanol and DME on board a Stena 'Scanrail' ship to evaluate its potential to reduce emissions and improve environmental performance. The project work showed that methanol and DME-based fuels are viable alternatives for reducing emissions from ships, but while it did lead to some interest in methanol-fuelled ships, so far no DME-powered ships have been built. Nevertheless, research work continues, including a project begun in 2019 by Maersk, in collaboration with a Chinese partner and researchers at the Danish Technical University (DTU). DTU has a demonstration facility for green DME production at its Risø Campus in Denmark, but admits that scale-up would present problems, including building large enough electrolysis plants and finding the requisite amount of biomass to power the process.

## Renewable DME

Acceptance of any new fuel requires it to overcome a variety of challenges; technical, commercial, and legislative. Work on DME has been progressing for many years now, and most of the technical challenges have been or are being overcome. The commercial and legislative challenges remain, however, and it seems clear that in order to overcome them, DME needs an additional environmental edge. Development work is thus now coming to focus upon renewable DME ('rDME'), in the hope that boosting its green credentials will attract tax credits and lower legislative barriers. A number of companies and research institutes are working on rDME, including the following:

## Enerkem

Canadian company Enerkem has concentrated on gasification of municipal waste as a source of syngas-derived products, and in 2018 announced that it had produced fuel-grade 'bio-DME' at its research centre at Westbury, Quebec. The company

said at the time that it had "tested and validated the production of fuel-grade bio-DME made from unrecoverable carbon-rich municipal solid waste" over course of over 1,000 hours of operations at its Innovation Centre. It also says that it intends to "further develop and optimise" this product stream, while "evaluating its potential commercial applications".

## Oberon Fuels

As mentioned above, Oberon Fuels is partnering with SHV Energy, the world's largest LPG distributor, to accelerate the use of rDME (via a waste gasification process) to reduce the carbon footprint of transportation fuel, including propane. In 2019 the state of California awarded Oberon a \$2.9 million grant to upgrade its existing DME pilot facility to demonstration scale and facilitate the first production of rDME in the United States, with a target production capacity of about 1.6 million gallons of DME per year (4,050 t/a). In February 2020 Oberon said that it is now hoping to further develop DME fuelling infrastructure and vehicle development, continue testing the use of rDME blended with propane, and leverage its collaboration with SHV Energy via its global distribution network "to facilitate greater use of rDME in numerous energy applications worldwide". In September this year, US LPG distributor Suburban Propane Partners LP took a 39% stake in Oberon Fuels, and will have the exclusive rights to work with Oberon to market and sell rDME and rDME/propane blends in the United States, Canada and Mexico.

## FLEDGED

Fledged is a European partnership across six EU countries, including six universities and research centres, as well as Frames Renewable Energy Solutions, Quantis, Econward Tech, and Sumitomo's Finnish subsidiary. It is developing a biomass gasification process for DME production, which will also use hydrogen generated from renewable energy. It is a four year project which concluded in October 2020, and has developed a sorption-based gasifier to convert 'second generation' biomass into syngas, in which a calcium oxide based sorbent circulator-gasifier and a combustor-calculator to produce a nitrogen free syngas without the use of an air separation unit; as well a sorption-based DME synthesis process which separates water

using the sorbent. The process avoids use of a water-gas shift module by adsorbing and recycling CO<sub>2</sub> from the gasifier. It can run on a variety of feeds, including woody biomass, municipal waste and agricultural waste.

## CO<sub>2</sub> to DME

Conversion of CO<sub>2</sub> directly to DME is something of a 'holy grail' for renewable DME production, and a number of companies and research institutions are working on processes. One such is Gas Technology International, which has been developing a process via a US ARPA-Energy grant from 2017-2020. It now has a catalytic membrane reactor and has produced a 1 kg/day prototype for long-term testing of fuel production. Of course, the journey from laboratory scale to working commercial plant is one often fraught with difficulties.

Meanwhile, while it is not a pure CO<sub>2</sub> to DME process, last year BASF announced plans for scale-up and commercialisation of a technology developed in collaboration with Linde which uses a novel one-step route for DME production from syngas.

The new concept is based on dry reforming of methane with carbon dioxide and the direct conversion of syngas to DME without a methanol intermediate step. BASF says that it "represents a major breakthrough that offers numerous commercial possibilities for energy-efficient, low-emission and cost-effective scaled production of DME and olefins using CO<sub>2</sub> as a feedstock". The process allows for a higher than 50% reduction in CO<sub>2</sub> emissions in the production of DME compared to conventional methods. BASF says that one potential application is what it refers to as "clean olefin production" – production of ethylene and propylene from natural gas. In June 2019 BASF signed a memorandum of understanding with Sichuan Lutianhua to co-develop a pilot production plant for the process in China, which was due to be completed this year.

Elsewhere, Haldor Topsoe is building its e-SMR demonstrator plant to produce 10 kg/hour of methanol from CO<sub>2</sub>-containing biogas in a similar hybrid process, but using electrical heating and a 'green' hydrogen feed to ensure fully carbon neutral production. The plant is due to be running by 2022,

and of course could easily be adapted for downstream DME production using Topsoe's own process.

## The future of DME

For the past two decades DME has been a promising syngas derivative that has never quite seemed to make the breakthrough that has been expected of it. It has made some inroads into the market as a substitute for LPG, and the recent project activity in Indonesia shows that there is still scope for this to be developed outside of China, where it is currently concentrated. As a vehicle fuel, there are plenty of encouraging signs, especially in niche markets like California, but it seems likely that in order to make a bigger breakthrough, renewable DME production will need to be developed. Numerous companies and research institutes are working on this, but at present only Oberon Fuels appears to be making commercial headway. However, BASF and Lutianhua's hybrid methane/CO<sub>2</sub>-fed pilot plant in China could be very interesting as a commercial demonstrator of a potential lower carbon route to DME.

## CONTENTS

What's in issue 368

## COVER FEATURE 1

The future of DME

## COVER FEATURE 2

Nitric acid carbon credits

## COVER FEATURE 3

Revamping ammonia plants

## COVER FEATURE 4

Plant digital solutions

NITROGEN+SYNGAS  
ISSUE 368  
NOVEMBER-DECEMBER 2020

BCInsight

Southbank House, Black Prince Road  
London SE1 7SJ, England  
Tel: +44 (0)20 7793 2567  
Fax: +44 (0)20 7793 2577  
Web: www.bcinsight.com  
www.bcinsightsearch.com

**NEED REPLACEMENT CATALYST?**

What can you do if the Hydrogen Removal Catalyst in your Urea Plant suddenly fails? Can't operate safely without it.

Need replacement catalyst? Whether it is next week, next month, or next year, please give us a call or drop us an email to talk about better options. Or visit our website at [www.vanguard-catalyst.com/CATOX](http://www.vanguard-catalyst.com/CATOX) for more information.

**FAIR PRICING**

Vanguard Catalyst was founded on the low overhead business model. Metals are charged at cost or transferred from your account to ours without additional fees. We believe in fair pricing.

**FAST DELIVERY**

Standard products are normally delivered in three to five weeks. Emergency replacements in as little as four days. Our business is designed to deliver your catalyst fast.

**FOCUSSED ON PGM**

Our manufacturing partner, Advanced Catalyst Systems, has the Platinum Group Metal chemistry expertise to tailor the perfect catalyst for your application.

**VANGUARD CATALYST**

[WWW.VANGUARD-CATALYST.COM](http://WWW.VANGUARD-CATALYST.COM)

Every five years since 1955, the Chinese government has prepared its 'Five Year Plan' for the country's economy over the coming half decade. This year, the 14th Five Year Plan is being drafted, and given the influence of the Chinese economy over the global chemical sector, its conclusions will be eagerly awaited.

*A hydrogen filling station in China. The government is aiming to have 1,000 similar by 2030.*



PHOTO: CHINA HERALD NEWS

# A blueprint for 2025

In late October China held the Fifth Plenary Session of the 19th Central Committee of the Communist Party. Its purpose was to discuss the forthcoming 14th Five Year Plan for the Chinese economy, which will be formally ratified in March 2021, and which will set the template for investment decisions over the period 2021-25. Given the importance of China's decisions to all global industries, the shape of the plan will have a major impact on the trading environment over the coming years, and agriculture and chemicals are no exception. It's worth remembering that the 13th Five Year Plan, which ends this year, saw China pivot to a strategy giving greater emphasis to the environment and less to industrial production, and led to mass shutdowns of urea plants in areas with poor air quality, while the previous, 12th Five Year Plan came in the wake of the global financial crisis and continued a massive industrial stimulus package that led to severe overcapacity in many industries.

The 13th Plan also set a cap for consumption of fertilizer at 2020 levels, and an expectation of falling demand going forward as the agricultural sector achieves more efficient nutrient use, and capped coal-fired power capacity at 1,100 GW. The potential impact of the new plan on the nitrogen and other syngas-derived industries could be a considerable one.

## Broad aims

The National Development and Reform Commission (NDRC) typically begins drafting the next plan two years before it is approved, so many of the broad outlines are already known. The 13th Five Year Plan set a target of 6.5% annual GDP growth for the country as a whole, although in reality this fell from 6.9% in 2015 to 6.1% in 2019, and is likely to be around 3% this year because of the Covid pandemic. It is believed the 14th Plan will aim for a more realistic rate of 5% out to 2025 but may be more flexible in terms of setting absolute numbers.

The 14th Plan has also been trailed to revolve around the theme of what the NDRC is calling "dual circulation". This means a coupling between the domestic economy ("internal circulation") and the global economy ("external circulation"), and ways of better integrating the two. This will no doubt continue to be built around the 'One Belt, One Road' initiative.

Other aims of the 14th Plan are expected to be a new emphasis on fostering urbanisation (mainly in developing metropolitan areas and city clusters), continued infrastructure investment and measures to support employment in small and medium-sized enterprises and improve the social safety net, and hence consumption.

## Environmental protection

The 13th Plan placed an unexpectedly strong emphasis on environmental protection. The 14th is expected to build on this. The country's target of achieving peak carbon emissions by 2030 was recently confirmed by President Xi Jinping in a virtual address to the UN General Assembly, and he added a new target – that China is aiming to be 'carbon neutral' by 2060. This goal will have significant consequences for the country's huge oil, gas, coal and resources sectors. One idea that has been floated is replacing the 13th Plan's energy consumption cap of 5 billion tonnes of coal equivalent with a carbon emissions cap.

Reducing the carbon intensity of the economy, especially heavy industry, will of course mean a continued move away from coal, which has powered China's industrial boom, and which still represents 66% of electricity generation capacity. Natural gas use, which made up 8% of energy consumption in 2019, is targeted to reach 16% by 2035. Renewables will of course play a major part, with the 14th Five Year Plan expected to highlight major investment in geothermal energy, solar and wind power, with a target of providing 18-20% of total electricity demand by 2025. There is also expected to be more nuclear power, as well

as carbon capture and storage projects and greater focus on energy efficiency.

Fertilizers and chemicals are among the most energy hungry industries, and one area where energy efficiency is likely to be promoted is in the continuing closure of older capacity in industries such as fertilizer, especially in areas where there is overcapacity. It will also mean that investment in new capacity is subject to much greater scrutiny. A recent government document on the chemical industry said that: "decisions on new production capacities must be taken with caution," and highlighted the methanol to olefins sector in particular. It is also likely to mean the continuing drift in the Chinese chemical industry away from sites which can pollute the environment close to major population centres and towards major industrial parks, as well as continuing tightening of environmental controls.

However, it may also mean that there is increased focus on a switch to capacity for which there are cleaner and more efficient production routes available. While still coal-based, it has been striking the extent to which urea production has switched in recent years away from smaller scale plants using older gasification technology which requires anthracite coal to larger scale bituminous based plants which are far more productive and efficient. In March CRU forecast that China would close nearly 13 million t/a of urea capacity over the period 2018-2023, but nearly 9 million t/a of this would be replaced by newer, more efficient capacity.

## Hydrogen

There is also a growing move to a 'hydrogen economy'. During the first six months of 2020 alone, 37 policies in support of the hydrogen economy have been published by various level governments, including 7 by central government authorities, and 30 by local governments. One of the areas of focus is on vehicular transport, with plans to encourage alternatives to oil-fuelled vehicles. In addition to its major focus on purely electric vehicles, China has said that it also hopes to have 50,000 hydrogen fuel cell vehicles on the road by 2025 and 1 million by 2030, by which time it aims to have 1,000 hydrogen refuelling stations, centred on Wuhan, which will have 100 of these and become a 'hydrogen city'. At present there is not a corresponding focus on producing the hydrogen from 'green' technologies – only 3% of China's hydrogen currently comes from green sources. However, given the country's commitment to net

zero carbon emissions by 2060, this seems likely to become an increasing focus. Using nuclear energy to generate hydrogen has also been suggested.

## Self-sufficiency: real and 'virtual'

Achieving domestic self-sufficiency in key areas has long been a Chinese policy. The country has been self-sufficient in urea production since the early 2000s, for example, and moved to self-sufficiency in ammonium phosphate production later in the decade. But following the trade war with the USA and the way that the Covid crisis has highlighted potential vulnerabilities in global supply chains, the move seems set to intensify and deepen. For example, China has been moving to self-sufficiency in sectors such as refining and petrochemicals, and gradually moving up the value chain to speciality and fine chemicals. This will be accompanied by more concentration on areas such as technical and process expertise and catalyst development in these areas.

One area which has become a focus is olefins. The 13th Plan aimed for a move from 67% to 92% self-sufficiency in polypropylene production – a factor which has driven the rapid investment in methanol to olefins capacity. In fact it has achieved around 87%, but the 14th Plan will no doubt seem renewed progress in this area. For ethylene the self-sufficiency figure is only around 62%, and as a result a large number of ethylene crackers are under development in China.

Where self-sufficiency cannot be achieved, it is likely that China will seek a form of 'virtual' self-sufficiency, via investment in overseas capacity that can feed back to China. Economic commentators have suggested that the 'One Belt, One Road' initiative may be a key part of this, in other words, that the aim will be for few, if any, imports to come to China except from Belt and Road initiative partner countries.

However, the drive to self-sufficiency also hints that China will be willing to continue to put up with domestic industry being less competitive than overseas suppliers and a cost per tonne basis, provided that the jobs and production remains in China.

## Agriculture

China must feed 20% of the world's population using only 7% of the world's arable land. The food supply chain and food security has consequently always been a key priority for the Chinese government and is regarded

as a national security issue. China is self-sufficient (or about 95% so at least) in many staples such as wheat, rice and corn, but nevertheless remains the largest importer of food in the world, and the figure is growing. China's food self-sufficiency rate has fallen from 100% in 2005 to 82% in 2017. A report released this year by the Chinese Academy of Social Sciences noted that by 2025, China will have a shortfall of about 130 million tonnes of food. Increasing urbanisation and an ageing population, as well as the potential impact of climate change are all exacerbating the problem, while increased animal rearing has increased the demand for eg soybeans to feed them. Most of China's food imports are soybeans.

The result of this trend has been a renewed focus on feed security. In August this year president Xi Jinping unveiled an initiative to cut food waste and make food security a priority, via strengthening assistance plans for the food sector, safeguarding food production resources, strengthening the country's grain reserve system. It also appears to have marked the end for a brief flirtation with using corn ethanol as a vehicle fuel. In 2017 China mandated that 10% of fuel would come from corn-derived ethanol, similar to mandates in the US and Brazil. However, this was abandoned in 2020 due to concerns over falling maize stocks.

Some of the drive to regain self-sufficiency will no doubt also feed back into 'virtual' self-sufficiency once more, via targeted investments and agreements overseas to ensure continuity of supply. This may be especially so in the soybean sector, where China currently produces only 15% of its own needs.

In terms of demand for fertilizer, China's application rates for nitrogen fertilizer are some of the largest in the world, and almost double the global average. But an increasing drive to greater nutrient use efficiency (NUE) is likely to see that fall over the period of the 14th Five Year Plan. To some extent, greater fertilizer use on the rapidly expanding fruit and vegetable sector has masked some of the decline in traditional cereal crop production. However, as the complexion of China's agricultural sector changes, increasing farm sizes and efficiency, greater use of multi-nutrient and speciality fertilizers, fertigation, and greater spread of experience and good practice fertigation will couple with the continued push from government to avoid nitrogen leaching into water courses and lead to falling application rates overall. ■

## CONTENTS

What's in issue 368

## COVER FEATURE 1

The future of DME

## COVER FEATURE 2

Nitric acid carbon credits

## COVER FEATURE 3

Revamping ammonia plants

## COVER FEATURE 4

Plant digital solutions

NITROGEN+SYNGAS  
ISSUE 368  
NOVEMBER-DECEMBER 2020

BCInsight

Southbank House, Black Prince Road  
London SE1 7SJ, England

Tel: +44 (0)20 7793 2567

Fax: +44 (0)20 7793 2577

Web: www.bcinsight.com  
www.bcinsightsearch.com

# 2020 A tumultuous year

A look back at some of the major events of 2020 for the nitrogen and syngas-based industries, as well as a look forward as to how 2021 might look.



PHOTO: UNICEF  
A shipment of Covid-19 P.P.E. arrives in Sudan.

This year has certainly been one of the most eventful in living memory, as the world has faced the huge disruption and loss of life brought on by the coronavirus pandemic. The virus has confined people to their homes for extended periods and shut down all manner of 'normal' economic activity, from long distance travel to – on occasion – routine visits to restaurants or attendance at concerts or sporting events. Beginning in earnest in China in February, and moving on to the rest of East Asia, as well as Europe and North America by the end of March, the pandemic led to extended 'lock-downs' for billions of people, and still continues to work its way around the world, with South America and India now badly affected, while the colder months in the northern hemisphere and more people spending time indoors are feeding a 'second wave' of cases in Europe and America.

The effect upon economies has been profound, as much of normal life has been forced to shut down. Oil and gas prices have slumped as demand has fallen, and most of the world has spent the year in recession. For the chemical process industries, much of the disruption has been via the almost complete shutdown of international air travel and associated quarantine regimes that mean people are simply not able to travel. Face to face conferences have become a thing of the past, and we have all had to become familiar with the ins and outs of video conferencing, with all of its foibles. Engineers have not been able to go to sites to oversee plant construction or start-ups or deal with production problems, leading to a much greater emphasis on the kind of digital plant services that we highlight elsewhere in this issue.

## Ammonia

On the market side, most governments have moved to try and protect farming and agriculture, and being an outdoor activity that lends itself to social distancing, the impact of Covid-19 on fertilizer demand has not been great, although restrictions at ports have led to some dislocations in the supply chain. However, periodic shutdowns or operating restrictions at industrial sites have led to a fall in demand for technical nitrogen. The reduction in demand has collided with an already oversupplied market, and while as prices have fallen, so some plants have been forced to idle. Some of these were temporary shutdowns, but some not. While Nutrien said that the idling of its PCS-02 ammonia plant on Trinidad in May was temporary, in September it announced that the PCS-03 ammonia plant at the same site would be closed down "indefinitely".

## Methanol

New methanol capacity during 2020 came on-stream at Bushehr in Iran (1.65 million t/a) and on Trinidad, where the Caribbean Gas Chemical Ltd facility will produce 1.0 million t/a at capacity, with a small DME side-stream. Two smaller new plants in India are also in commissioning. Covid had a major impact on methanol markets; use of methanol for fuel blending as well as in other fuel end uses like MTBE was constrained by the fall in car use. Falling oil prices and rising coal prices in China also impacted upon the economics of methanol to olefins production, the main driver of Chinese imports. Methanol prices nosedived, and a wave of temporary shutdowns began, led by Methanex, who idled their Titan plant on Trinidad in March, and their Chile and New Zealand plants in April. MHTL also idled their number three methanol plant on Trinidad in April. Other investment decisions were postponed – work on the 1.8 million t/a South Louisiana Methanol plant was halted in April, and Methanex deferred work on its third plant at Geismar.

Methanex's idled Titan plant.



## Urea

In spite of the pandemic, new urea capacity has continued to enter an already oversupplied market. In Egypt, the new KIMA plant at Aswan began production in the second quarter, with a capacity of 400,000 t/a of urea. Ramagundam Fertilizers and Chemicals Ltd at Ramagundam in India followed in June, adding another 1.27 million t/a – part of the new wave of Indian urea capacity, and the huge Dangote complex began producing urea in September, after start-up was deferred from March by the Covid pandemic and a shortage of available engineers – this will ultimately ramp up to a full capacity of 2.6 million t/a.

There have been some shutdowns as well – Petrobras closed its final remaining 650,000 t/a plant at Araucaria in Brazil in January, and the rationalisation of Chinese urea capacity continued, balancing new capacity somewhat, but the market remains oversupplied. Even so, there were some bright spots on the demand side of the equation – India had a good monsoon season and record demand for urea, importing 5 million tonnes in July alone, and leading to predictions of record imports for 2020 as a whole. Brazil's imports also continue to rise, both due to rising demand and falling production as plants are idled.

## Sustainable production

Outside of the short term, this year has seen terrible bushfires rage first in Australia in January, and then across the west coast of the United States in September and October, a reminder of the extreme weather events that we face as atmospheric CO<sub>2</sub> levels rise. China has unveiled new targets on carbon reduction, and the focus on sustainable chemical production has continued to intensify. This year we have reported on reducing the CO<sub>2</sub> intensity of hydrogen production (July/August), low carbon methanol production (Jan/Feb), hydrogen for fuel cells (July/August), and green ammonia production and sustainable nitrate production (May/June). There has also been increasing interest in ammonia's use either as a hydrogen carrier to bridge the gap between renewable electricity sites to final consumers, and even as a clean-burning marine fuel.

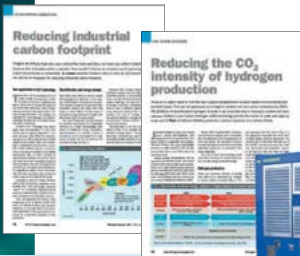

This year has seen a continued push towards more sustainable production.



## Next year

Unfortunately, in spite of a massive global push towards finding and delivering a vaccine, it looks as though Covid is going to be with us for most of next year as well. Intermittent lockdowns and restrictions are sure to continue, and although industries have mostly managed to find a way of working around restrictions for the time being, it's sure to continue to dampen down any recovery in the short term. Governments have borrowed heavily to support populations unable to work, and may be reluctant to commit to large investments until they see a clear end in sight.

However, an overhang of current builds is still out there, and much more urea capacity is due to come onstream next year. Of India's five government-sponsored projects, following this year's start-up at Ramagundam, three more plants are due to begin operations next year. The Gora-khpur, Barauni and Sindri plants were reported in August to be 80%, 74% and 73% complete, respectively, and are all looking at start-up in 2021, each with a capacity of 1.3 million t/a. Brunei Fertilizer Industries is also due to complete a new 1.3 million t/a urea plant next year, adding to the glut of capacity in the urea sector. It remains to be seen however whether 2020-21 produces a hiatus in capacity building that may rescue oversupplied markets.

## Beirut

Sadly, the year has seen tragedy over and above that provided by Covid-19. In August, the explosion of an estimated 2,700 tonnes of ammonium nitrate being stored in the port of Beirut once again threw an unwelcome spotlight upon the AN industry. Outside of a few investigations into how existing stocks of AN are being handled in a few countries, there do not currently seem to be any new restrictions in train, but it is a salutary reminder of the risks that the industry must continue to try to mitigate through good practise.



## Technology

Other technological developments in 2020 included Haldor Topsoe's launch of its new TITAN reformer catalyst range at the Nitrogen+Syngas conference in the Hague. We also reported on a new ammonia synthesis catalyst developed by Casale/Clariant in the March/April issue. In our July/August issue we reported on how new technologies and digital solutions are making construction sites safer, and in Sep/Oct we reported on different approaches to solving problems in nitric acid plants (see graphic from this article, right).

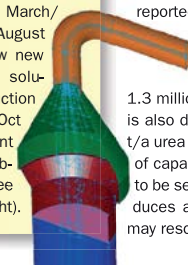

Watch free fertilizer market presentations

Argus deliver concise and insightful webinars analysing the nitrogen, phosphate, potash, sulphur and sulphuric acid markets. The webinars are offered on-demand and live – and are completely free to watch.

Watch the free webinars here:  
[www.argusmedia.com/webinars](http://www.argusmedia.com/webinars)



[www.nitrogenandsyngas.com](http://www.nitrogenandsyngas.com)

CONTENTS

What's in issue 368

COVER FEATURE 1

The future of DME

COVER FEATURE 2

Nitric acid carbon credits

COVER FEATURE 3

Revamping ammonia plants

COVER FEATURE 4

Plant digital solutions

NITROGEN+SYNGAS  
ISSUE 368  
NOVEMBER-DECEMBER 2020

BCInsight

Southbank House, Black Prince Road  
London SE1 7SJ, England  
Tel: +44 (0)20 7793 2567  
Fax: +44 (0)20 7793 2577  
Web: [www.bcinsight.com](http://www.bcinsight.com)  
[www.bcinsightsearch.com](http://www.bcinsightsearch.com)

# New concepts for ammonia plant revamps

thyssenkrupp Industrial Solutions discusses a revamping concept to reduce CO<sub>2</sub> emissions by replacing some of the hydrogen in the front end of the ammonia plant with green hydrogen, KBR and Casale report on revamp options to increase the capacity of vintage ammonia plants in the former Soviet Union, Johnson Matthey presents a novel integrated ammonia flowsheet for the production of ammonia, methanol, urea and UFC and Arvos | Schmidtsche Schack discusses the benefits of a new process gas boiler.

## THYSSENKRUPP INDUSTRIAL SOLUTIONS

### Ammonia plant revamping with green hydrogen

K.Noelker

Concepts for green ammonia plants have been presented, where “green” means that ammonia is produced from hydrogen which originates from electrolysis of water, using electricity generated from renewable sources<sup>1,2</sup>. Such ammonia would be produced with no or much lower CO<sub>2</sub> emissions, compared to existing schemes based on hydrocarbons, e.g. natural gas.

Green hydrogen from an electrolysis unit can also be fed to an existing ammonia plant in order to lower its CO<sub>2</sub> emission by combining it with hydrogen from the conventional ammonia plant front end (synthesis gas generation). Plant modifications using green hydrogen can be anything between the two extreme cases of:

- replacement of hydrogen from the plant front end by electrolytic hydrogen at unchanged ammonia production, or
- addition of hydrogen to increase the ammonia production (possible only if the ammonia synthesis unit is not the bottleneck of the plant).

In this case study, the impact on an existing plant is described, when 10% of the hydrogen fed to the synthesis is replaced by hydrogen from an external (carbon-free) source as shown in Fig. 1. The main focus is on how much the CO<sub>2</sub> emission can be reduced, whether there are any obstacles for such a modification and how they can be avoided.

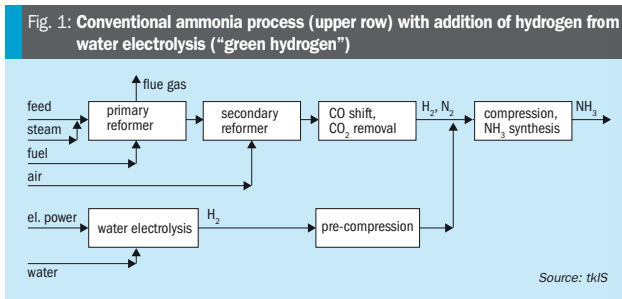

#### Impact of modifications on process units

The reference case for the simulation is an actual uhde® ammonia plant but the study results are equally valid for any ammonia plant based on primary and secondary reforming with stoichiometric process air and with heat recovery for HP steam generation. Electrolysis data are also taken from the uhde®/thyssenkrupp Industrial Solutions alkaline water electrolysis (AWE) process.

It is obvious that the feed gas consumption of the reformer will also decrease by about 10% but there remains a number of questions to be answered:

- What is the change in reformer fuel demand?

- What is the change in steam export?
- Will the operating parameters remain in the limits of design?
- Finally, and referring back to the purpose of the change, what is the reduction of the CO<sub>2</sub> emission and operating cost of the plant?

Generally, the modification takes load from the plant front end and thus one might not at first glance expect any problem to arise. The addition of hydrogen at the end of the front end has an impact especially on the reforming unit of the ammonia plant. Process and performance parameters are summarised in Tables 1 and 2.

While the amount of hydrogen from the front end is being reduced, the nitrogen demand has to remain approximately the

Table 1: Process parameters of reference case and modification with 10% external hydrogen

Stream	Reference case	Modification	% Reduction
Natural gas feed, kmol/h	3,849	3,502	9.0
Natural gas fuel, kmol/h	1,272	1,131	11.1
Heat absorbed by reformer tubes, MW	185.6	155.3	16.3
Burner air ratio	1.10	1.25	n.a.
CO <sub>2</sub> available at CO <sub>2</sub> removal inlet, kmol/h	3,757	3,430	8.7
Total HP steam production, t/h	531	496	6.7

Source: thkIS

Table 2: Plant performance parameters of reference case and modification with 10% external green hydrogen

Stream	Reference case	Modification including electrolysis	% Reduction
Steam export, t/h	111.9	81.0	27.7
CO <sub>2</sub> emission (reformer and process), t CO <sub>2</sub> /t NH <sub>3</sub>	1.68	1.52	9.5
CO <sub>2</sub> emission (as above plus steam export outbalanced by aux. boiler), t CO <sub>2</sub> / t NH <sub>3</sub>	1.68	1.56	7.0

Source: thkIS

same because it is dictated by its content in the ammonia produced. This means the natural gas feed and process steam to the reformer are lower than in the reference case, while the air to the secondary reformer is kept unchanged. The front end has therefore to produce a synthesis gas with a H/N ratio of less than the stoichiometric number of 3.

Since the air feed to the secondary reformer is fixed, but its feed stream is lowered, the energy available in the secondary reformer is sufficient to sustain more reforming reaction and therefore allows for a higher inlet CH<sub>4</sub> concentration. Consequently, the heat pick-up of the primary reformer tubes is not only lowered by 10% due to lower flow, but additionally by lower CH<sub>4</sub> splitting and an 18°C lower outlet temperature. Consequently, the primary reformer is seeing a more than proportional reduction in absorbed heat by not only 10% but 16%.

This shift of the reforming duty from the primary to the secondary reformer leads to a higher temperature rise between the inlet and outlet of the secondary reformer which in the simulated example amounts to 180 K instead of 168 K in the reference case. Luckily, the effect of the lower inlet temperature is the dominating one so the outlet temperature is not higher than normal and thus stays within the design limit.

In the convection bank of the primary reformer another challenge arises

because there is less flue gas stream but the rate of the process air stream to be preheated has not changed. Therefore, without any adjustment not enough heat would be available. In the simulation it is postulated that all preheating temperatures shall be maintained as before. In order to achieve that, the air ratio of the combustion is being increased, from 1.10 to 1.25. The air and flue gas flow rates remain within the design limits of the blowers. Alternatively, one could allow for a lower feed/steam preheating temperature in order to lower the duty in the convection bank. Since the primary reformer is operated at lower throughput there is enough margin available to increase the portion of preheating duty in the reformer tubes.

The heat available in the front end for HP steam generation decreases while the conditions in the synthesis section and its HP steam generation remain mostly unchanged. Therefore, the decline in steam generation is less than 10% (Table 1).

A critical consequence of this is the change in process temperature between the waste heat exchanger and superheater downstream of the secondary reformer. The modification results in a rise in temperature, which must be limited in order to avoid the risk of metal dusting. In the example presented here, the temperature goes up by 12°C only and remains below

the design temperature. This should be checked in each project case by case.

Downstream of the reforming unit, the situation is less critical. Due to the lower overall gas flow, catalyst volumes in the HT and LT shift are more than sufficient and the outlet CO shift concentration drops. This leads to a lower temperature rise in the methanator, but still sufficient to maintain the reaction, and to the very welcome fact that there are less inserts in the syngas to the synthesis section.

In the CO<sub>2</sub> removal unit, the overall gas flow and CO<sub>2</sub> to be separated are about 10% below the reference process so no performance problems are expected. The only issue may be the total amount of CO<sub>2</sub> if in the reference case it is all being consumed by a downstream plant. In case of no or little CO<sub>2</sub> usage, the reduced amount of CO<sub>2</sub> venting leads to the desired effect of producing ammonia with a lower CO<sub>2</sub> footprint.

#### Overall performance

The overall plant performance parameters of the reference configuration and the modification are summarised in Table 2.

There is a significant drop of more than 27% in the steam export from the ammonia plant. This is caused by nearly unchanged operation of many consumers (e.g. refrigeration, process air and syngas compressor turbines) despite lower steam production from waste heat (see above).

For a newly built plant the steam system can be designed around this situation, but for an existing plant the owner has to decide how to handle that. In the worst case, the reduced steam export in the modified operating case will lead to a steam deficit in another unit (e.g. a urea plant) which has to be met by higher production in the auxiliary boiler. However, there may also be cases where the lower steam export can be accepted if its consumer can be replaced by one using an alternative form of energy, like electric power.

The 10% addition of hydrogen from a non-fossil source does not increase the plant CO<sub>2</sub> emission. The total CO<sub>2</sub> emission, consisting only of reformer stack and CO<sub>2</sub> vent, is reduced by about 10% (absolute and per tonne of ammonia). In case the lower steam export has to be replaced by a gas fired auxiliary boiler, and its CO<sub>2</sub> emission is included in the comparison (which seems fair), the reduction is only 7%.

## CONTENTS

What's in issue 368

## COVER FEATURE 1

The future of DME

## COVER FEATURE 2

Nitric acid carbon credits

## COVER FEATURE 3

Revamping ammonia plants

## COVER FEATURE 4

Plant digital solutions

NITROGEN+SYNGAS  
ISSUE 368  
NOVEMBER-DECEMBER 2020

BCInsight

Southbank House, Black Prince Road  
London SE1 7SJ, England

Tel: +44 (0)20 7793 2567

Fax: +44 (0)20 7793 2577

Web: www.bcinsight.com  
www.bcinsightsearch.com



A change from natural gas to electricity is not only made for economic reasons. Putting together the ammonia production cost resulting from natural gas and electricity (including the electrolysis, which is the biggest power consumer) shows that the overall production cost is the same for the reference case and modification at a gas cost of \$5/million Btu (LHV) and \$15/MWh for electricity.

The electrolysis option becomes more attractive when some kind of tax or allowance for CO<sub>2</sub> emission has to be considered. Of course, this increases the production cost for both cases greatly, but, for example, at an emission cost of \$30/t CO<sub>2</sub>, the overall cost of the modification with electrolytic hydrogen from "green" power is approximately \$5/t NH<sub>3</sub> lower.

### Options for process control

In the conventional plant, the H<sub>2</sub> to N<sub>2</sub> ratio adjustment is made by regulating the feed flows of natural gas and process air, typically keeping the natural gas constant and matching the process air so that the H<sub>2</sub>/N<sub>2</sub> ratio at the feed to the synthesis loop is close to the stoichiometric ratio of 3.

In the modified system, with the external feed a third variable comes into play. One scenario is that the external H<sub>2</sub> fluctuates in the same way as the available electricity from a renewable source, in which case the ammonia plant will have to deal with and balance out greater fluctuations than usual. Instant reaction is not always required because the loop itself acts as a buffer and small changes in the ratio will result in only a slightly lower conversion.

In the other scenario, if electricity is available continuously without fluctuations, this is perfectly suited for ratio control since the load of the electrolyser and the hydrogen supply can be adjusted within seconds, being a system with less inertia than the ammonia plant front end.

### Other benefits

The external H<sub>2</sub> stream or a part of it can also be added to the process in ways besides that shown in Fig. 1. One option is to use this H<sub>2</sub> as a hydrogenation stream for the desulphurisation, thus avoiding the usual H<sub>2</sub> recycle over the front end. Another option is to compress the H<sub>2</sub> to synthesis pressure using a dedicated H<sub>2</sub> compressor and

combining the streams there. This would save steam consumption of the syngas compressor train and might help with the shortfall of steam export mentioned above.

### Summary

Summarising the above, there are a few points to observe when replacing part of the hydrogen from the front end by an external source, especially the following:

- outlet temperature secondary reformer;
  - energy balance of convection bank;
  - gas temperature between reformed gas waste heat boiler and superheater;
  - availability of CO<sub>2</sub> for downstream products;
  - steam export;
  - system control if H<sub>2</sub> feed is fluctuating.
- However, as shown there are ways to avoid any adverse impact. ■

### References

1. "Sustainable ammonia for food and power", *Nitrogen+Syngas* no. 354, pp. 44-53 (Jul-Aug 2018).
2. "Carbon reduction and the nitrogen industry", *Nitrogen+Syngas* no. 346, pp. 34-37 (Mar-Apr 2017).

## KBR

# Revamp of vintage ammonia plants using KRES™ technology

A. Ivanov, K. Nguyen and A. Nahar

KBR's experience in the design of ammonia plants dates back to the first plants commissioned in 1944. Since then, KBR ammonia process technology has undergone a number of significant innovations and improvements, which have enabled the owners of KBR-designed ammonia plants to obtain consistently safe, reliable and cost-effective operation. KBR has licensed, engineered or constructed 244 ammonia plants worldwide making it the world's leading ammonia technology licensor.

KBR's track record in ammonia plant revamping includes more than 100 projects since 1995 and ranges from small to large increase in production capacity and reduction of energy consumption. In particular, KBR Reforming Exchanger System (KRES™) offers the potential for increasing the capacity of the front-end of existing plants by up to 30%, by using high temperature process waste heat

exiting the secondary reformer (or auto-thermal reformer) to reform additional flow of natural gas.

This article highlights how the application of KRES™ technology to vintage ammonia plants, originally designed for 1,360-1,420 t/d, can successfully boost their capacity to 2,100 t/d and above as well as reduce their energy consumption.

### Vintage TEC and GIAP ammonia plants

In the period from 1973 to 1988, 45 TEC and GIAP ammonia plants were built in the Soviet Union. The design of those plants was based on M.W. Kellogg technology (now KBR) or similar and had the nameplate capacity of 1,360 and 1,420 t/d of ammonia. The original design varied slightly for TEC and GIAP plants but generally included the following sections:

- hydrodesulphurisation;

- primary and secondary reforming with 2+1 downstream waste heat boilers (WHB);
- high temperature and low temperature shifts converters (HTS and LTS);
- CO<sub>2</sub> removal section, using potassium carbonate solution (Benfield) for TEC and amine solution for GIAP;
- ammonia synthesis;
- refrigeration, by way of ammonia compressor for TEC and absorption chilling units (ACU) for GIAP.

Over the years, almost all those plants were revamped to bring their capacity to 1,500-1,800 t/d. The modifications typically included:

- revamping main machinery;
- modifying primary reformer: radiant section re-harped, additional MF coil and process air coil, new feed preheat coils;
- halting the fired heater;
- Installing additional parallel LTS converter (TEC);

- upgrading the activator of the Benfield unit (TEC), replacing MEA solution with aMDEA (GIAP);
- modifying ammonia converter basket;
- installing hydrogen recovery unit;
- adding air-cooled heat exchangers and condensers.

Most of the revamps were carried out by replacing the existing equipment with bigger units using the same process design. Only in rare exceptions were licensors involved and new technology solutions implemented. The maximum capacity achieved through implementing such a modification is about 1,800 t/d, which reflects the limit of the main process equipment. As practice shows, any further increase in capacity without implementing innovative technology solutions requires much higher capital investment per additional tonne of product, increases the specific energy consumption and reduces the lifetime and reliability of operation of the plant. This is a problem faced by the owners of ammonia plants built all over the world in the 1970s and 1980s.

The main bottlenecks for further capacity increase are generally the rotating equipment, reforming capacity, performance of reformer WHB, CO<sub>2</sub> removal section and ammonia synthesis capacity.

KBR, as licensor of more than half of all built and operated ammonia plants, has been involved in a large number of revamping projects all over the world, from small to large size. In approaching any new projects, KBR applies the lessons learnt from over 100 revamping projects as well as from the 244 grassroot plants licensed and designed.

By applying innovative technology solutions, KBR has demonstrated that it is possible to increase the capacity of vintage TEC and GIAP ammonia plants further to reach 2,100 t/d of ammonia and more, while improving the energy consumption to match the performances of state-of-art grassroots modern plants.

### Revamping project challenges

Revamping existing vintage plants has distinct challenges, not only during project execution stages but also over the entire plant lifecycle. Among other factors, special attention is required for the following:

- performance of the revamped plant on a long term basis;

- ensuring high level of reliability of the plant after the revamping;
- considering all costs associated with the revamp project;
- optimising the project schedule to avoid any disruption to the operation of the existing plant (e.g. hook-up of new units during normal turnaround period);
- reviewing and supporting project execution during all phases.

KBR not only places high emphasis on providing cost-effective technology solutions for the overall plant, but also offers the support for the entire project life cycle, including detailed engineering design review, construction advisory, commissioning and start-up support. These involve ammonia revamping specialists in all disciplines and ensure successful project execution, achieving the performance as per design.

The revamping of the whole process plant requires highly specialised modelling capability and proven technology that KBR is in a position to offer due to the large number of ammonia plants in operation that KBR has designed and licensed and the large technology portfolio that KBR offers.

### Revamp scheme (2,100+ t/d)

KBR innovative technology solutions to revamp existing TEC or GIAP plants to 2,100 t/d and above include the following main features:

- **increase reforming capacity:** debottleneck the reforming section by implementing KBR's proprietary KRES™ technology, along with mechanical know-how to integrate KRES™ to the existing secondary reformer and waste heat boiler;
- **upgrading CO<sub>2</sub> removal** unit based on modern CO<sub>2</sub> Removal Technology (working with third Party) for increased throughput and reduce energy consumption;
- **increase synloop capacity** by installing a proprietary KBR design add-on converter (or re-using existing spare converter shell with new radial-style catalyst baskets when available) and by optimising synloop operating parameters to minimise modifications required in the synloop and refrigeration system;
- **convert to dry loop:** existing synthesis loop is converted to a dry loop using liquid ammonia in a new KBR design ammonia wash system (unitised syngas dehydrator);

- **machinery upgrades:**
  - **air compressor train:** revamp to handle higher capacity and improve efficiency/reduce steam consumption.
  - **syngas compressor and turbine:** revamp to handle higher capacity and improve efficiency/reduce steam consumption.
  - **refrigeration compressor turbine:** revamp to improve efficiency/reduce steam consumption.

These revamp solutions also provide a large reduction in specific energy consumption. KBR also have various technology and revamp solutions to achieve further reductions in energy consumption. These include but are not limited to combustion air pre-heat, saturator, dry loop with molecular sieve, better heat integration, secondary waste heat recovery.

Key modifications are described in the following sections.

### Front end

The general revamp scheme of the front-end of the ammonia plant is presented in Fig. 1.

First, the air compressor train and natural gas compressor should be revamped to achieve higher capacity and reduce steam consumption.

Second, the radiant box size and structure of the existing primary reformer furnaces is generally inadequate to accommodate any further revamping aimed at achieving stable and reliable operation above 1,850 t/d ammonia capacity. Extensive modification of the full box, such as adding rows and expanding size of radiant box, involves high cost and very long shutdown period. Therefore, a cost-effective approach for revamping of vintage ammonia plant requires innovative technology solutions in the reforming section.

Third, the original design waste heat boilers need to handle large increase in heat load, suffer more frequent failure, which affect plant reliability.

These key bottlenecks, primary reforming and waste heat boilers, are resolved by the installation of the KBR KRES™ exchanger, which provides the additional reforming duty by using high grade process heat exiting the secondary reformer (or auto-thermal reformer). The details of construction and references of KRES™ are presented in earlier publications<sup>1-6</sup>.

The benefits of the KRES™ are:

## CONTENTS

What's in issue 368

## COVER FEATURE 1

The future of DME

## COVER FEATURE 2

Nitric acid carbon credits

## COVER FEATURE 3

Revamping ammonia plants

## COVER FEATURE 4

Plant digital solutions

NITROGEN+SYNGAS  
ISSUE 368  
NOVEMBER-DECEMBER 2020

BCInsight

Southbank House, Black Prince Road  
London SE1 7SJ, England

Tel: +44 (0)20 7793 2567

Fax: +44 (0)20 7793 2577

Web: www.bcinsight.com  
www.bcinsightsearch.com

Fig. 1: Revamp scheme of front end

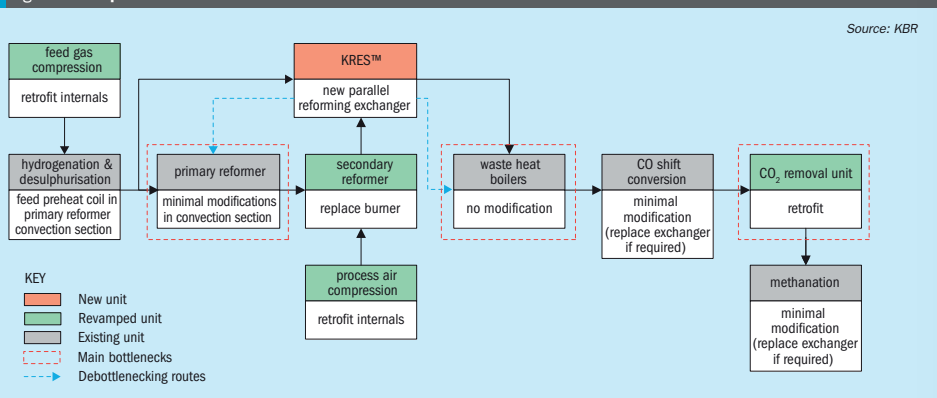

- avoid major expensive modifications and long shutdown period of reforming furnace area;
- improve thermal efficiency of existing furnace system as convection duty relative to the radiant duty is higher (compared to no KRES™ scenario), thus enhancing ammonia plant energy efficiency and reducing CO<sub>2</sub> emissions per tonne ammonia;
- avoid major expensive modification/replacement of secondary reformer waste heat boilers;
- No change to ID fan as flue gas flow, temperature and fan head is not increased;
- Reduce front-end pressure drop and maximise synthesis compressor suction pressure;
- avoid/minimise changes in HP steam/BFW system/drum/pump;
- well-proven and reliable technology with 25+ years operational experience in ammonia plants;
- open-ended catalyst tube design which eliminates thermal and mechanical stress – ensuring high reliability;
- easy loading and unloading of catalyst using the same tube bundle saving cost and downtime of replacement.

Due to the increased quantity of process air required for higher ammonia production, the existing secondary reformer generally needs burner replacement.

One of the key challenges is how to physically connect the existing secondary reformer with the KRES™ exchanger and the KRES™ exchanger with the existing waste heat boiler. These connections need to be done via refractory lines (transfer



Fig. 2: KRES™

PHOTO: KBR

Fig. 3: Revamp scheme of back end

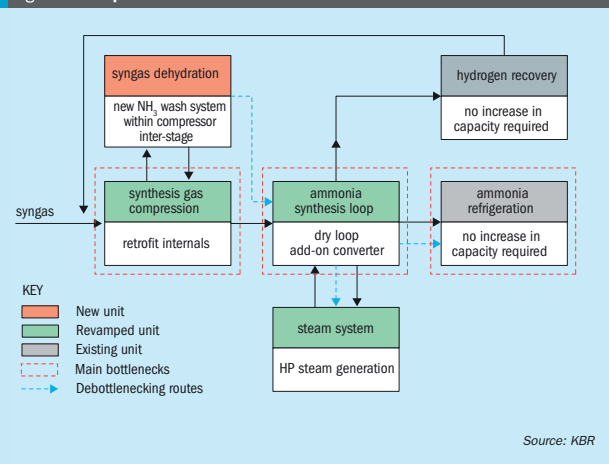

Source: KBR



Fig. 4: Add-on ammonia converter.

PHOTO: KBR

lines). KBR has successfully provided tailored solutions in different types of ammonia plants, both KBR and non-KBR plants, which require different approaches.

For TEC/Kellogg or GIAP plants, KBR has developed an optimal arrangement and routing for the transfer line systems to and from KRES™, which minimises site work. This was implemented in KBR's recent revamp in Russia.

The existing reforming waste heat boilers are generally suitable for post-revamp operation due to the decrease of heat duty after installation of KRES™.

The shift reactors and methanator do not usually require modification. However, internals can be modified to reduce pressure drop.

The CO<sub>2</sub> removal system is revamped for increased throughput using the most up-to-date technology available. All existing equipment is re-used after the revamp. Existing column internals typically require modification as well as solution pumps.

Finally, the front-end pressure profile is studied in detail and optimised in order to maintain process gas pressure as high as practically economic.

### Back end

The general revamp scheme of the synthesis loop is presented in Fig. 3.

The syngas compressor and driver typically require modification to achieve higher capacity and reduce steam consumption. Usually the compressor internals can be retrofitted.

A new ammonia wash system, (unitised syngas dehydrator), can be installed in the inter-stage of the syngas compressor to dry the make-up gas. The primary purpose of the new ammonia wash system is to remove water from the synthesis gas before it enters the synthesis loop. This allows conversion of the existing "wet" loop into a more energy-efficient "dry" loop. KBR's ammonia wash system (unitised syngas dehydrator) is a compact design with minimum footprint achieved by stacking up and integrating a vertical wash exchanger on the syngas dehydrator column. Conversion of "wet" loop into "dry" saves power on the syngas circulator by improving conversion per pass in the synthesis loop and reducing circulation flow. This scheme also results in increased energy efficiency due to reduced cooling and heating usage.

## CONTENTS

What's in issue 368

## COVER FEATURE 1

The future of DME

## COVER FEATURE 2

Nitric acid carbon credits

## COVER FEATURE 3

Revamping ammonia plants

## COVER FEATURE 4

Plant digital solutions

NITROGEN+SYNGAS  
ISSUE 368  
NOVEMBER-DECEMBER 2020

BCInsight

Southbank House, Black Prince Road  
London SE1 7SJ, England  
Tel: +44 (0)20 7793 2567  
Fax: +44 (0)20 7793 2577  
Web: www.bcinsight.com  
www.bcinsightsearch.com

The required additional ammonia production is obtained by installing a new add-on ammonia converter, (Fig. 4). The following benefits can be achieved:

- higher per pass ammonia conversion;
- increased condensation of ammonia inside water or air cooler, avoiding changes in refrigeration system (no medication required to refrigeration machine);
- reduced duty on the synthesis gas compressor, enabling cost effective and reliable retrofit of its internals;
- improved energy efficiency of whole plant by saving power on synthesis machine and duty on refrigeration system;
- avoids changes in high pressure synthesis loop equipment and piping by avoiding an increase in circulation flow as well as an increase in velocities and heat duty on most equipment;
- generates additional HP steam in the synthesis loop in a new boiler which provides a flexible steam balance.

The temperature of the flow leaving the ammonia converter is high enough to generate HP or MP steam. HP steam generation offers energy benefit whilst the MP steam generation avoids having a long pipe run for the HP saturated steam.

## Refrigeration

The outlet ammonia concentration from the add-on converter is significantly higher than the concentration from the existing converter, thus the additional ammonia made can be condensed against air water cooler. This allows the existing refrigeration compressor to operate at similar refrigeration loads compared to the current operation; hence, no modification is expected.

## Steam system

Application of the KRES™ technology reduces the high pressure steam generated in the front-end waste heat boiler. This reduction is compensated by the high pressure steam generated in the synloop boiler, thus balancing the steam system. Modifications affecting the steam system have already been outlined in the previous sections. The main modifications include:

- revamp to improve energy efficiency of major turbine drivers;
- the steam generated from the new loop boiler is connected to the steam superheaters;
- the steam superheat coil can be modified to preheat HP steam to higher temperatures.

## Cooling water system

Generally, no change/increase is expected to the cooling water system. However, if the cooling water reserve is available, then additional cooling can be implemented for better efficiency.

## Relief and flare system

The revamp of TEC or GIAP plants typically require modernisation of the flare system, reusing the existing stack for the front-end and installation of a separate stack for the back-end.

## Preliminary energy saving

Energy saving for the above scheme ranges from 1 to 1.5 Gcal/t (LHV) depending on the extent of modification implemented to reduce the energy consumption. KBR can recommend the most cost-effective approach in a feasibility study.

## Conclusions

Revamping of vintage ammonia plants is an attractive way to extend their lifetime and increase profitability. KBR offers cost effective proven technology solutions for ammonia plant revamps to increase the production capacity and enhance energy efficiency. The competitive advantages of KBR technology were successfully demonstrated during implementation of the revamp project for Dorogobuzh JSC (Acron Group). This approach for revamping of TEC and GIAP plant can be efficiently applied to other plants. ■

## References

1. LeBlanc J.R., Schneider R.V., Wright K.W., Lai, B: "Simple, safe and reliable KRES™: First commercial application", Ammonia Technical Manual (1996).
2. Malhotra A., Kramer P., Singh S.: "Revamp of Liaohé's ammonia plant with KRES™ technology to reduce natural gas usage"; Ammonia Technical Manual (2004).
3. Singh U., Singh S., Malhotra A.: "Successful operating experience of CFCL ammonia plant revamped with KBR KRES™ technology"; Ammonia Technical Manual (2011).
4. Singh S., Jing A: "KRES™ Technology Makes Ammonia Plant Revamping Viable"; GazChem, (2007).
5. Singh, S.: "New KBR ammonia synthesis loop revamp technology improves plant energy efficiency"; Nitrogen + Syngas Conference, (2009).
6. Ivanov A., Singh S.: "KBR KRES™ technology – 25 years of successful application in ammonia plants"; Nitrogen + Syngas Conference (2019).

## CASALE SA

# Casale revamping of GIAP ammonia plants

F. Baratto, S. Panza, M. Mazzamuto

GIAP, which stands for "Gosudarstvennogo Instituta Azoti Promishlennosti" or "State Nitrogen Industry Institution", developed a domestic Russian technology for the production of ammonia, based on the Kellogg process.

The front end of a GIAP plant is very similar to Kellogg plants, the main exception being the CO<sub>2</sub> removal section, where columns are designed with special trays in some cases (in AM76/AM80 schemes) equipped with internal coils to provide heat.

Another feature of these plants is the use of absorption coolers instead of cooling cycles based on ammonia compression that is proposed by all other licensors.

GIAP built 37 plants from the early 1960s through the 1980s. The institute left the ammonia plant market just before the collapse of the Soviet Union in the early 1990s. There are currently 25 operating ammonia plants designed according to GIAP technology AM70/AM76 or AM80 in Russia and the former USSR countries.

Casale has developed and patented specific process schemes and technologies for the revamping of these plants, in particular to increase their capacity and make them stable throughout the year. Most of these technologies have already been applied by Casale for the revamping of GIAP ammonia plants.

While the following information discusses the revamping of GIAP plants, most of the concepts and technologies are applicable to any plant type.

## Capacity increase – AARP (AXY) section

A problem that is commonly faced when the capacity of GIAP plants is increased, or when the air temperature increases during the summer months, is the cooling limitation of the existing AXY (the Russian acronym of AARP, aqua ammonia refrigeration package).

The lack of AARP cooling capacity often results in a serious bottleneck for plant capacity increase, or reduced plant production during the hot season.

The typical upgrading developed for AARP sections concerns the ammonia condenser (item 903): air cooled condensers are normally replaced with evaporative condensers to improve the AARP distillation section.

Fig. 1: Typical AARP revamping approach

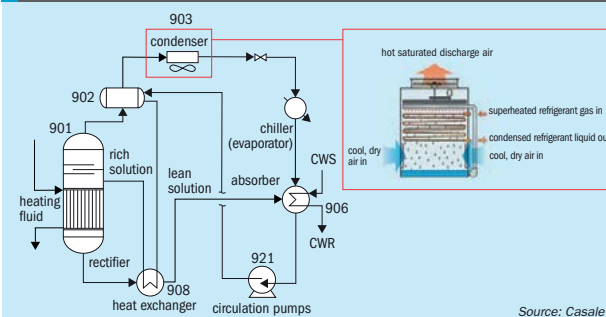

Source: Casale

Fig. 2: Additional CW exchangers providing greater surface area in ammonia absorber

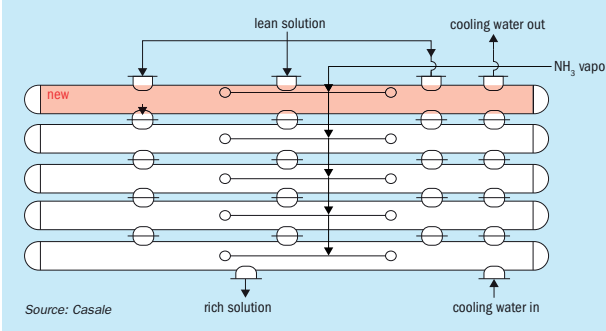

Source: Casale

Fig. 1 shows a typical AARP revamping approach.

Thanks to the lower condensation temperature achievable with evaporative condensers, it is possible to decrease the regenerator operating pressure and thus temperature approach in the regenerator reboiler. This results in an increased distilled ammonia flow rate and consequently enhanced AARP cooling capacity.

Unfortunately, if nothing is done to also improve the ammonia absorption (item 906), the improvements can result in modest or even disappointing overall results.

AARP cooling capacity increase is inevitably tied to ammonia vapour absorption: if more liquid ammonia is sent to the process chillers, more ammonia will need to be absorbed.

The ammonia absorption by means of regenerated lean aqua-ammonia solution is in fact as critical as rich solution regeneration: a weak vapour absorption can lead to a pressure and temperature increase in the chillers, which would have a detrimental effect on the process cooling.

Additionally, ammonia absorption is influenced by the operating conditions (temperature and flow rate) of the cooling water.

Casale's approach is to closely analyse all AARP sections, in order to understand which ones are preventing the system from reaching its design capacity. In particular:

- ammonia condensation (item 903);
- ammonia absorption (item 906);
- rich solution regeneration (items 901, 902, 908).

## CASE STUDY Dorogobuzh, JSC (Acron Group)

PJSC Acron is one of the fastest growing fertilizer producers, not only in Russia, but also globally. In 2017, Acron's management set the ambitious goal to achieve the highest possible capacity on its operating plants with cost-effective investments. The revamping of one of its TEC ammonia plants in Dorogobuzh was selected as a pilot case. KBR technology was selected for the revamping project, offering an opportunity to introduce on the territory of Russia/CIS countries its well proven technologies in the first-of-its-kind project of revamping of TEC /GIAP plants. The project implementation period was also very ambitious, targeting completion by 2019.

The TEC ammonia plant in Dorogobuzh had a nameplate capacity of 1,360 t/d. Over the years the plant's output was increased to 1,725 t/d.

Upon completion of the revamping project in December 2019, the plant achieved the guaranteed capacity of 2,100 t/d with simultaneous energy savings by 9%. Moreover, the plant reliability was enhanced as demonstrated by uninterrupted operation of the plant since start-up.

The project team included KBR as licensor, basic engineering designer and proprietary equipment supplier, R&D Acron Engineering (Acron Group) as general designer, Dorogobuzh (Acron Group) as general manager and organiser of construction.

The scope of the revamp included the state-of-art KBR design solutions KRES™ and the cold wall add-on ammonia converter as main design features for modernisation of the reforming and synthesis sections, respectively. Most of fabrication and installation works was performed during normal plant operation and only the tie-in of new equipment was done during a normal plant turnaround within 42 days. Upon stabilisation of performance after start-up the plant achieved all guaranteed figures. ■

## CONTENTS

What's in issue 368

## COVER FEATURE 1

The future of DME

## COVER FEATURE 2

Nitric acid carbon credits

## COVER FEATURE 3

Revamping ammonia plants

## COVER FEATURE 4

Plant digital solutions

NITROGEN+SYNGAS  
ISSUE 368  
NOVEMBER-DECEMBER 2020

BCInsight

Southbank House, Black Prince Road  
London SE1 7SJ, England

Tel: +44 (0)20 7793 2567

Fax: +44 (0)20 7793 2577

Web: www.bcinsight.com  
www.bcinsightsearch.com

It should be noted that each system can have more than one limiting section.

The most common example is represented by the difficulties in achieving the required AARP performances even after the replacement of item 903. Often, once the limitation in ammonia condensation is removed, the ammonia absorption (item 906) becomes a much more difficult bottleneck to deal with.

Two revamping approaches are known to overcome limitations in the ammonia absorber (item 906):

The first approach is to provide additional CW exchangers for the existing ammonia absorber (see Fig. 2). The drawback of this approach is the higher cooling water consumption. For this reason it is not always applicable due to limitations on cooling water availability (CW pumps and/or cooling towers) and it increases plant overall energy consumption.

The second approach is the Casale cooling module, a new technology developed by Casale for its clients, aimed at reducing the duty requirement in the existing absorber.

Ammonia vapours are routed to a pre-absorption column where they are washed with lean NH<sub>3</sub>-H<sub>2</sub>O solution coming from the AARP regenerator.

Semi-lean solution from the pre-absorption column bottom is divided into two streams: one stream is cooled at the expense of air and DW evaporation in a dedicated cooling loop, the second stream is sent to the existing absorber to complete absorption of the pre-absorption column overhead.

Since most of the ammonia vapours coming from the process chillers are absorbed in the pre-absorption column, the load on the existing absorber is drastically reduced.

The Casale cooling module can be designed to overcome existing absorber limitations, increasing overall AARP cooling capacity, or even to completely replace item 906 (AARPs with no CW consumption can be designed following this principle).

The Casale cooling module is installed upstream of the existing absorber and will partially condense ammonia vapours at the expense of air. Cooling water can therefore be saved in the existing absorber CW exchangers.

Fig. 3 shows a sketch of the absorber after implementation of the Casale cooling module (for the existing absorber refer to Fig. 2).

In this case, the Casale cooling module is carefully designed in order to

**Table 1: Benefits achieved in AARP G thanks to Casale cooling module**

	Base case	Revamped case (with Casale cooling module)
Plant production, t/d	1,373	2,100
AARP G cooling capacity, Gcal/h	4.76	5.96
AARP G CW consumption, m <sup>3</sup> /h	1,206	471

Source: Casale

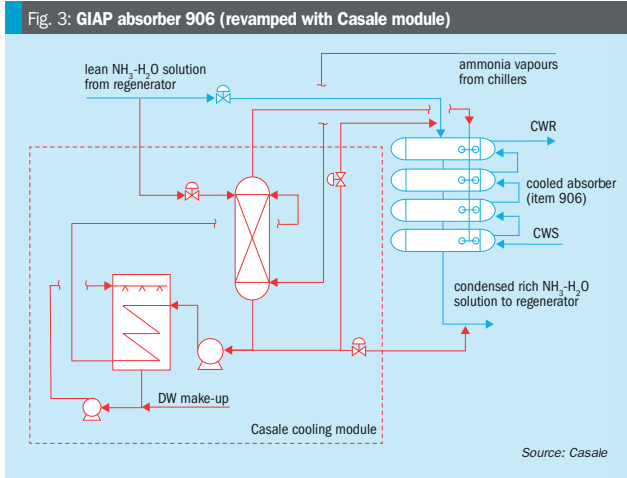

minimise the pressure drop and maximise the achievable process benefits.

Two important results can be achieved with the Casale cooling module:

- AARP ammonia vapour absorption power will be increased, allowing the AARP cooling capacity to be increased with the maximum benefit.
- Cooling water can be saved from existing absorber CW exchangers, creating room on CW pumps and cooling towers for additional users (e.g. compressor inter-stage coolers, new process water coolers, new lithium-bromide units, new AARPs).

The example in Table 1 shows the expected effect of the Casale cooling module if applied on AARP G (-10°C thermal level) of a reference GIAP AM76 plant.

The client's request was to both increase plant production and improve overall energy consumption.

As shown in Table 1, AARP cooling capacity has been increased (restoring most of its original design cooling capac-

ity) and, at the same time, cooling water consumption has been reduced by 60% with respect to the base case.

In this example, the cooling water saved in AARP G was used to cover the additional consumption of the compressor's inter-stage coolers and new CW exchangers (both necessary for the increased plant capacity).

The Casale cooling module improved the project economics by avoiding the need for an expensive new cooling water circuit (i.e. new additional circulation pumps, new additional cooling towers etc.).

Casale also has experience in the design and supply of new aqua ammonia refrigeration packages. In the revamping of a GIAP plant in 2015, Casale supplied a new unit of 10 Gcal/h cooling capacity at a thermal level of -10°C, the biggest ever installed in Russia. This new unit uses 3.5 kg/cm<sup>2</sup> LP steam to drive the refrigeration cycle. Casale engineered the integration of the new unit within the existing ammonia absorption refrigeration system and was responsible for all the project steps, from basic engineering up to delivery.

**Table 2: Performance of the new aqua ammonia refrigeration package**

	Design value	Test run value
Production, t/d	1,700	1,700
606 B (loop chiller) syngas outlet temperature, °C	-5	-10 to -12
NH <sub>3</sub> vapour temperature to AARP absorber, °C	-10	-12 to -14
Specific steam consumption, kg steam/kg NH <sub>3</sub>	1.01	0.85 to 0.98
AARP operating pressure in absorber, kg/cm <sup>2</sup> g	1.7	0.9 to 1.2

Source: Casale

Table 2 shows the performance of the new aqua ammonia refrigeration package.

Besides the classical AARP based on -10°C or +1°C ammonia operating temperatures, Casale has also developed a new version particularly suited for energy saving, summer stabilisation and negligible consumption of utilities.

The new AARP is designed assuming +5°C and +10°C respectively as ammonia operating temperatures, which allows the use of evaporative condensers or dry air coolers instead of shell-and-tube heat exchangers for the absorption phase.

The use of cooling water as cooling medium is therefore not required in the new scheme; additionally, the heating source is very low pressure steam (1-2 barg) or even hot water.

**Capacity increase – CO<sub>2</sub> removal section**

The CO<sub>2</sub> removal section is one of the most critical in ammonia plants and it is usually a bottleneck when the capacity is raised above the plant design capacity.

The original design of the CO<sub>2</sub> absorber is not usually suitable for revamped conditions, since the existing internals must cope with higher process gas and amine solution flow rates.

Casale acquired the license and all know-how of the CO<sub>2</sub> removal process developed and owned by Karpov Institute of Physical Chemistry. Hence, Casale is the only company able to revamp original AM70 & 76 CO<sub>2</sub> absorbers by applying the original design philosophy.

Casale multipipe trays (Fig. 4) can be designed to cope with the new column hydraulics, allowing the low CO<sub>2</sub> slip, characteristic of GIAP plants, to be maintained and overcoming the difficulties given by the simple installation of random packing in place of trays.

Replacing existing absorber trays with random packing can undermine the CO<sub>2</sub>

separation efficiency, leading to an excessive CO<sub>2</sub> slip and consequent higher syngas inert content.

Due to their specific design which provides a high contact time between phases, multipipe trays (existing GIAP absorber trays or new Casale multipipe trays) are almost twice as efficient than common trays and random packing and replacing them with a different technology (e.g. commercial trays or random packing) would imply a much higher amine solution circulation rate than Casale multipipe trays to maintain control of CO<sub>2</sub> slip.

Unfortunately, such additional flow rate is rarely available due to the physical limitations of lean and semi-lean pumps. Additional pumps can be added, but increase the revamping cost, jeopardising the investment payback time.

The advantages of Casale multipipe trays can be summarised as:

- high efficiency;
- efficiency estimated to be as much as double that of standard sieve trays;

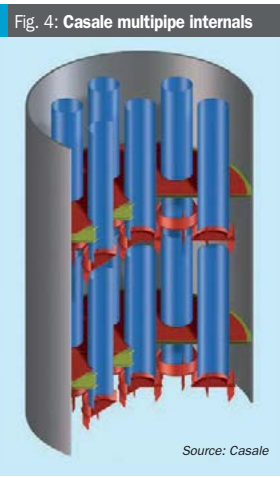

- no wall effects – preferential paths and distribution problems are avoided, unlike random packing absorbers;
- a higher approach to equilibrium is achieved;
- higher active area compared to standard sieve trays, allowing for the design of smaller absorption columns.

Casale has already successfully applied this technology for the revamping of GIAP plants, in particular, absorber tray revamping making these sections suitable for a capacity of at least 2,100 t/d.

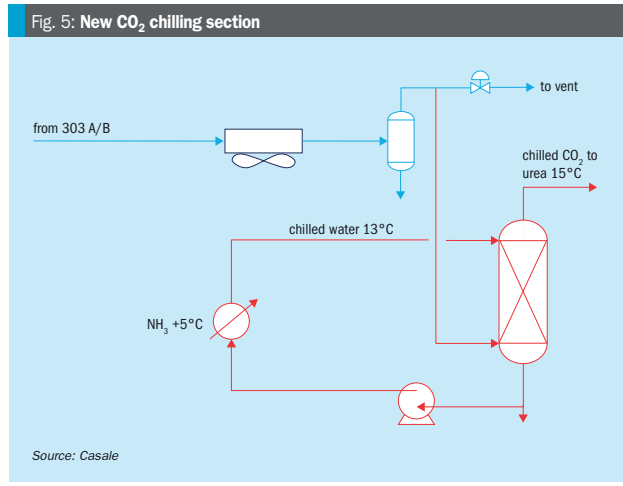

**CONTENTS**

What's in issue 368

**COVER FEATURE 1**

The future of DME

**COVER FEATURE 2**

Nitric acid carbon credits

**COVER FEATURE 3**

Revamping ammonia plants

**COVER FEATURE 4**

Plant digital solutions

NITROGEN+SYNGAS  
**ISSUE 368**  
NOVEMBER-DECEMBER 2020

**BCInsight**

Southbank House, Black Prince Road  
London SE1 7SJ, England  
Tel: +44 (0)20 7793 2567  
Fax: +44 (0)20 7793 2577  
Web: www.bcinsight.com  
www.bcinsightsearch.com

Fig. 6: Internal separation device for new and revamped tower

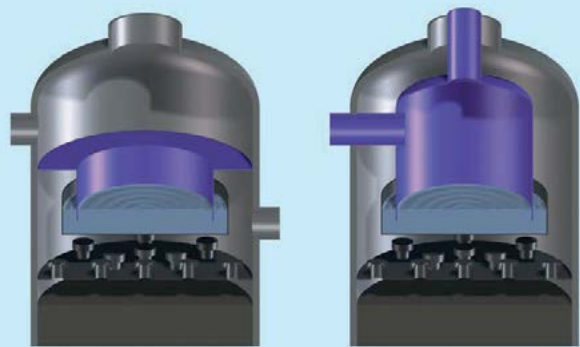

Source: Casale

Fig. 7: Simplified scheme between items 301 and 303A/B

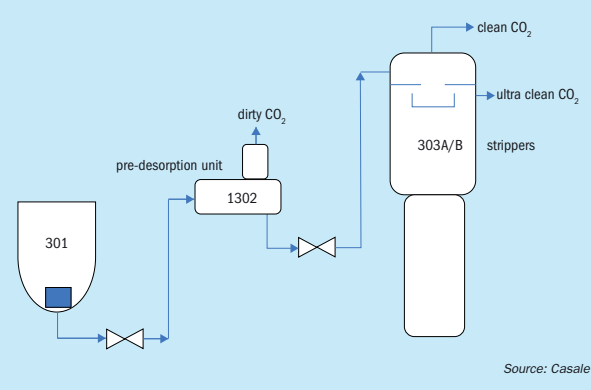

Source: Casale

Another section strongly limited in case of capacity increase (especially during summer) is CO<sub>2</sub> compression in the urea plant.

To overcome this, Casale proposes the installation of a CO<sub>2</sub> chilling section as shown in Fig. 5 where red identifies new lines/equipment.

After water is separated in item 322, CO<sub>2</sub> is diverted to the new chilling column 3001 where it is cooled down to 15°C by circulating chilled water at 13°C.

Thanks to the new CO<sub>2</sub> chilling section it is possible to debottleneck the CO<sub>2</sub> compressor in the urea plant: volumetric flow at the compressor inlet decreases by about 10-15%, making it possible to reduce the power requirements/costs of a new

parallel compressor for a urea capacity increase.

Additionally, due to the lower feed gas temperature, the electrical consumption of the CO<sub>2</sub> compressor is reduced (savings: ~350kW @ 1,320 t/d urea and ~435kW @ 1,800 t/d urea).

CO<sub>2</sub> delivery pressure at battery limits will not be decreased with respect to base case since the pressure drop of the additional column is very low and can be easily recovered by a small increase of the operating pressure of the strippers 303A/B. The regeneration penalty coming from the slightly higher operating pressure of the CO<sub>2</sub> stripper is negligible.

Water is chilled by an additional CO<sub>2</sub> water chiller (item 3003) fed by liquid

ammonia from AARP A. Such ammonia is evaporated at 4.3 kg/cm<sup>2</sup>g so that the evaporating temperature is around 5°C, avoiding any freezing risks.

A CO<sub>2</sub> chilling section very similar to the one proposed here was successfully commissioned in two Romanian ammonia plants respectively in 2015 and 2016, and in an ammonia plant located in Saudi Arabia.

### Improve CO<sub>2</sub> purity

The existing CO<sub>2</sub> removal section of the GIAP AM76 plant is usually already equipped with a clean/dirty separation system located in the regenerator top.

However, solution degradation, mechanical issues or other problems may have affected this system/device, and in any case, the clean CO<sub>2</sub> flow rate should be maximised.

Such improvement can be accomplished by the internal modification of towers 303A/B, or by means of the installation of a pre-desorption unit. Casale offers both solutions.

### Internal separation device

The solution involving the modification of the regenerator top (solution applicable to any regenerator/stripper) foresees the installation of a separation device (Fig. 6), where dirty CO<sub>2</sub> is separated from clean CO<sub>2</sub>; proper sealing avoids any mixing between the two streams.

This technology can be applied both to amine and hot potassium based CO<sub>2</sub> removal sections. The maximum recovery of clean CO<sub>2</sub> is usually about 70-80% of the overall CO<sub>2</sub> recovered by the CO<sub>2</sub> removal section, the balance is a dirty stream of CO<sub>2</sub>.

### External vessel solution

In case of a pre-desorption unit installation, the process flow scheme is modified as follows (see Fig. 7).

The pre-desorption unit is installed between the absorber, item position 301, and the regenerators 303 A/B; the rich amine stream coming from the absorber is de-pressurised and fed to the new pre-desorption unit to separate the released gas from the liquid, a small washing tower is usually provided in case part of the CO<sub>2</sub> released needs to be recovered.

The pre-desorption unit is designed with the proper residence time. The pre-desorption unit internals are designed to improve the H<sub>2</sub> release (degassing of the amine solution). The CO<sub>2</sub> stream released



PHOTO: CASALE

Fig. 8: Pre-desorption unit installed in a GIAP ammonia plant.

from the pre-desorption unit top contains more than 6-7 mol-% H<sub>2</sub> (dirty CO<sub>2</sub> stream).

The pre-desorption unit (Fig. 8) is located at a certain height from the ground in order to provide the capability to operate within a certain pressure range and in order to optimise the H<sub>2</sub> desorption from the amine solution.

The pre-desorption unit is installed upstream of item 303A/B and is operated ideally up to the range 2.3-2.8 kg/cm<sup>2</sup>g, therefore the final elevation of this new equipment is selected in order to allow stable operation at these conditions.

Considering these operating parameters, the regenerators could produce ultra-clean CO<sub>2</sub> (that should be enough for the new urea plant) and also a new stream of clean CO<sub>2</sub> with less than 500 ppm vol maximum content of H<sub>2</sub> (this content could be further reduced by lowering the operating pressure of the pre-desorption unit, or by installation of a solution/solution new exchanger with low pressure drop).

To provide the previous operating conditions, modifications should also be made to the top of item 303A/B; the bottom vortex breaker of item 301 is also typically modified to reduce the entrained H<sub>2</sub> in the amine rich solution fed to the pre-desorption unit.

### Capacity increase - synthesis loop

The ammonia converter in GIAP plants is normally a bottleneck for capacity increase. The maximum achievable capacity without replacing the original converter or adding

a second converter in series or parallel operation is around 1,850-1,900 t/d.

However, thanks to Casale modifications to converter 601 internals and to the availability of the new AmoMax-Casale catalyst, it is possible to achieve a maximum production of 2,000+ t/d without adding new converters to synthesis loop.

### Ammonia converters internals modification

One of the most important modifications to the internals to improve the operation of this converter is the feeding line to the interchanger.

The interchanger located between the second and the third converter is fed from the bottom with a new dedicated line and valve (Fig. 9), reducing the relevant pressure drop and improving the operation efficiency of the revamped ammonia converter. This solution has been applied by Casale in more than a dozen of converters, similar to the GIAP one, in ammonia converters located in China, Saudi Arabia, Trinidad & Tobago, Belgium, Canada and the USA.

The old top interchanger feeding nozzle can be reused to feed the existing quench torus located at the outlet of the first bed (as an additional nozzle parallel to the existing one), reducing the feeding pressure drop for this service and making the converter more reliable and efficient (the second and third bed will be optimised to achieve better performance).

Thanks to all of these modifications the main valve will be less throttled and the synthesis loop will have a lower pressure drop.

Fig. 9: New bottom feeding for ICH

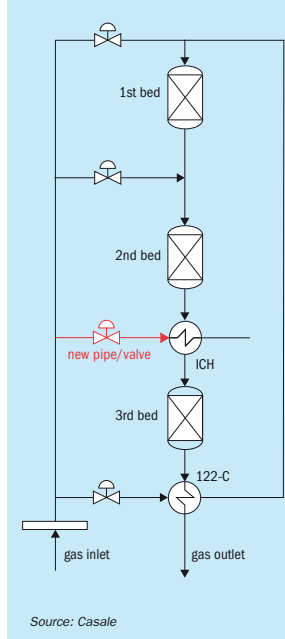

Source: Casale

### Amomax-Casale

AmoMax-Casale is a new ammonia synthesis catalyst developed by Clariant and Casale particularly for use in Casale ammonia converters.

AmoMax-Casale is an evolution of the well-known, wustite-based catalyst, AmoMax® 10 and represents the latest innovation in ammonia synthesis catalysts. AmoMax-Casale retains the same superior resistance to ageing, poisoning and mechanical strength of AmoMax® 10 but is significantly more active.

Catalyst activity has been evaluated up to 25% higher than the standard iron-based catalyst (wustite or magnetite catalysts).

The superior performances offered by AmoMax-Casale, compared to catalysts offered by competitors, allows a further increase ammonia conversion per pass improving project economics. This feature allows the loop recycle rate and the loop pressure to be reduced and/or the ammonia production to be increased.

AmoMax-Casale catalyst consists mainly of ferrous oxide (wustite) with a tailor-made and optimised set of promot-

## CONTENTS

What's in issue 368

## COVER FEATURE 1

The future of DME

## COVER FEATURE 2

Nitric acid carbon credits

## COVER FEATURE 3

Revamping ammonia plants

## COVER FEATURE 4

Plant digital solutions

NITROGEN+SYNGAS  
**ISSUE 368**  
NOVEMBER-DECEMBER 2020

**BCInsight**

Southbank House, Black Prince Road  
London SE1 7SJ, England

Tel: +44 (0)20 7793 2567

Fax: +44 (0)20 7793 2577

Web: www.bcinsight.com  
www.bcinsightsearch.com

Table 3: AmoMax-Casale catalyst

Composition	
Fe oxides, wt-%	89-96
K <sub>2</sub> O, Al <sub>2</sub> O <sub>3</sub> , CaO, others, wt-%	4-11
Operating temperature range, °C	350-550
Operating pressure range, kg/cm <sup>2</sup>	90-600
Density range, kg/m <sup>3</sup>	2,800-3,300

Source: Casale

Table 4: USA plant vs GIAP plant comparison

	USA plant	GIAP
Plant production, t/d	>2,000	2,007
Catalyst type	AmoMax	AmoMax-Casale
Catalyst volume, m <sup>3</sup>	42.3	43.3
Converter outlet pressure, kg/cm <sup>2</sup> g	235.6	216
Inerts in syngas inlet converter, mol-%	10.7	11
Ammonia at converter outlet, mol-%	17	18.5

Source: Casale

Fig. 10: Differences between AmoMax-Casale and standard iron catalyst

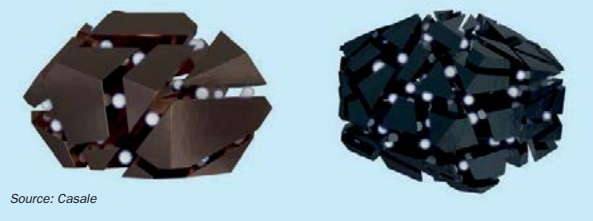

Source: Casale

ers that stabilise the iron crystallites and increase significantly the surface area of the activated catalyst (see Fig. 10).

Technical features of AmoMax-Casale are shown in Table 3.

AmoMax-Casale has been successfully applied in a Central American plant very similar to GIAP plants (started-up in December 2019). Amomax-Casale has been installed in the third bed of an existing ammonia converter, providing a superior conversion per pass in the existing synthesis loop.

The converter internals were modified as per the previous description (new inter-changer feeding line and valve).

As a result of the Casale converter revamp, the synthesis loop can now run at a much lower pressure than before (about 10 bar lower) and, at the same time, with an inert content much higher (about 50%

higher than before), resulting in a tangible energy saving and a plant capacity increase above nameplate capacity.

There are also Casale references for operation at 2,000 t/d with a single ammonia converter.

Table 4 summarises the main data related to a plant located in the USA where the operating conditions, the ammonia synthesis converter and the catalyst volume are close to those expected for an existing GIAP reactor.

### Summer stabilisation

Ammonia plants in Russia and the former USSR countries are often limited during summer time because of the unfavourable ambient conditions; ambient air temperature can be quite high (>30°C)

which impacts the cooling capacity of the air coolers as well as of the cooling water exchangers installed in the ammonia plant.

For GIAP AM76 plants, poorer performance of item 604 in the synthesis loop (air cooler condenser) overloads the ammonia chiller 606 and consequently the relevant AARP-10. Such loss of cooling capacity can reduce plant output by as much as 100-200 t/d during summer.

A simple way to solve the issue is to install a chilled water exchanger or an ammonia chiller (for instance with ammonia +5°C), just downstream of item 604.

Respectively, a chilled water exchanger would require the installation of a lithium/bromide unit, while an ammonia chiller would require a new AARP. Casale has experience to supply both.

In case additional cooling water is not available (limitation given by existing CW pumps or cooling towers), the installation of a new cooling tower would be required, which is normally quite expensive.

In light of this, Casale has developed a new arrangement focused on the reduction of cooling water used by the plant biggest AARPs (i.e. AARP "A" and AARP "I"), without impacting (or possibly even improving) their cooling capacity. The new arrangement is possible by the installation of new equipment i.e. the Casale cooling module, described earlier.

Basically, the existing AARP is modified taking into consideration that the ammonia vapours coming from the chiller, once washed/contacted with the lean solution release heat. By accomplishing most of the absorption in the new Casale cooling module it correspondingly reduces the requirement of the other existing absorption equipment (item 906). Eventually the cooling water requirement is hugely reduced, and additionally the cooling water still fed to the absorber (item 906), after heat exchange, is sent back to the existing cooling tower at a temperature 1-3°C lower than the current design making the cooling tower operation more efficient and effective.

A new single Casale cooling module can be provided for both AARPs, allowing plant production to be stabilised during the summer months (i.e. maintaining winter production levels throughout the year).

In case of lack of cooling water an effective alternative would be to also install a brand new Casale AARP equipped with absorber and condenser designed with dry air coolers, therefore liquid ammonia is provided to the plant back end requiring low steam pressure at battery limits. ■

## JOHNSON MATTHEY

# Retrofitting with Integrated ammonia flowsheets

T. Ithell

Johnson Matthey (JM) is a leader in sustainable technologies and a market leader in the development of catalyst and process technology in the ammonia, methanol and formaldehyde industries. With a heritage in ammonia dating back to the first decade of the 20th century, JM currently offers a range of high performance catalysts, leading edge technologies and diagnostic services to its customers. Johnson Matthey's range of DAVY™ technologies offers design, licence and commissioning expertise. The combined skills and experience of catalysts and process design is ideally suited to the development of innovative syngas flowsheets.

The integration of the ammonia and methanol processes into a single flowsheet can exploit the common upstream syngas generation unit operations. There is a history of methanol and ammonia coproduction from a common feed. Methanol synthesis has even been used as a carbon oxides removal stage in the flowsheet to produce ammonia from coal. Developments in ammonia production technology from naphtha and natural gas meant that a single stream ammonia production was more economic than the historic coproduction concepts.

Either downstream use of methanol in an ammonia complex, or changeable market conditions can now make the flexibility of a single process to produce both ammonia and methanol attractive. Through the combination of industry proven technologies, the synergies between ammonia and methanol production can be maximised. This allows the environmental impact of the twin productions to be minimised, and the operating costs and energy consumption of the coproduction scheme to be optimised.

## Methanol coproduction

### Methanol synthesis

The reactions involved in the synthesis of methanol from syngas are as follows:

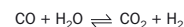
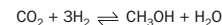
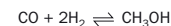

The synthesis of methanol is favoured by high pressure, moderate temperature, high levels of carbon dioxide and low levels of water.

The methanol industry today is almost entirely based on the low pressure methanol technology and high performance catalysts developed by ICI, and continually improved by Johnson Matthey since its acquisition of the business. Johnson Matthey has licensed over 100 grassroots methanol plants using their leading technology, and the skills and experience in catalysis and process design within JM lend themselves to the development of novel revamps for the synthesis of methanol on ammonia plants.

The requirement for carbon oxides in the feed for the methanol synthesis section means that there are various locations within an ammonia process for the coproduction of methanol which make use of the residual carbon oxides in the process. The selection of location for a coproduction retrofit is mainly dependent on the desired methanol production rate since this dictates a required level of CO and CO<sub>2</sub> in the feed but is assessed on a case by case basis.

### Operation

Johnson Matthey's high and stable activity KATALCO™ methanol synthesis catalyst allows methanol production to be carried

out at low temperatures that minimise the formation of by-products such as high alcohols, hydrocarbons, aldehydes and ketones.

Reduction of the methanol synthesis catalyst can be considered similar to that of the low temperature shift catalyst, and it is possible to design for the use of the existing reduction gas system.

### Coproduction using syngas inlet HTS

#### Flowsheet

In general, for cases requiring a relatively high production rate of methanol, the carbon oxides level upstream of the high temperature shift (HTS) are most attractive. In this flowsheet, the syngas from the secondary reformer waste heat boilers on the ammonia plant is passed through a desaturation stage to reduce the water content and then heated to methanol synthesis temperatures. A fraction of the CO and CO<sub>2</sub> is converted to methanol in a suitable once-through methanol converter. The product methanol is recovered in a crude state and sent to a distillation section for refining to product specifications. The unreacted syngas is passed through a saturation stage to return the removed water to the stream and reheated to the HTS inlet temperature before returning to the ammonia plant. This is illustrated in Fig. 1.

Fig. 1: Block diagram showing methanol synthesis retrofit using syngas exit the secondary reformer as the feed

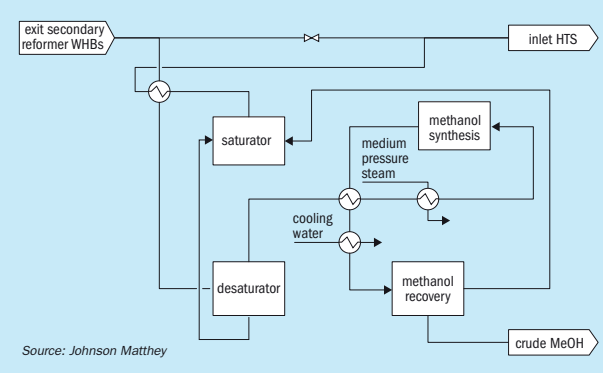

Source: Johnson Matthey

## CONTENTS

What's in issue 368

## COVER FEATURE 1

The future of DME

## COVER FEATURE 2

Nitric acid carbon credits

## COVER FEATURE 3

Revamping ammonia plants

## COVER FEATURE 4

Plant digital solutions

NITROGEN+SYNGAS  
**ISSUE 368**  
 NOVEMBER-DECEMBER 2020

**BCInsight**

Southbank House, Black Prince Road  
 London SE1 7SJ, England

Tel: +44 (0)20 7793 2567

Fax: +44 (0)20 7793 2577

Web: www.bcinsight.com  
 www.bcinsightsearch.com

**Benefits**

Advantages of a retrofit in this form are that there is a single break in and return point to the existing ammonia plant and it has little impact on the operation of the existing equipment.

A once through methanol synthesis system allows the capital cost of the equipment to be kept at a low, reasonable value. The nature of the upstream process on the ammonia plant means that there is a high level of nitrogen in the feed syngas which results in very high flowrates, and therefore high equipment costs, for circulating systems. The configuration also allows for continual operation of the ammonia plant without the methanol section running and for simple start-up of the methanol section in parallel to the ammonia plant.

A benefit of installing the methanol synthesis retrofit upstream of the HTS is that any additional CO slip from the methanol section as a result of methanol synthesis catalyst deactivation can be accommodated in the existing shift section. Therefore, any loss of production of methanol is offset by the increase in ammonia production as a result of the increased hydrogen produced in the shift section. The increase in carbon dioxide exit the shift section is removed in the existing CO<sub>2</sub> removal stage.

The once through system is designed such that operation is as simple as possible, and the plant with the retrofit in place can be operated with existing staffing levels.

**Ammonia plant impact**

Since the synthesis of methanol consumes hydrogen which would otherwise be used in ammonia synthesis, it is necessary to adjust the operation of the existing ammonia plant to maintain a 3:1 H:N ratio in the syngas being fed to the ammonia synthesis loop. The operation of the reforming section can be adjusted such that the syngas leaving the methanol synthesis retrofit is suitable for ammonia conversion.

The front end of the ammonia plant can also be updated to accommodate some or all of the reduction in ammonia rate associated with the introduction of the methanol synthesis retrofit.

The synergies between the production of ammonia and methanol can be maximised via close collaboration and integration between the design of the methanol synthesis retrofit and the adaptation of the existing ammonia technology. The global strategic alliance agreement

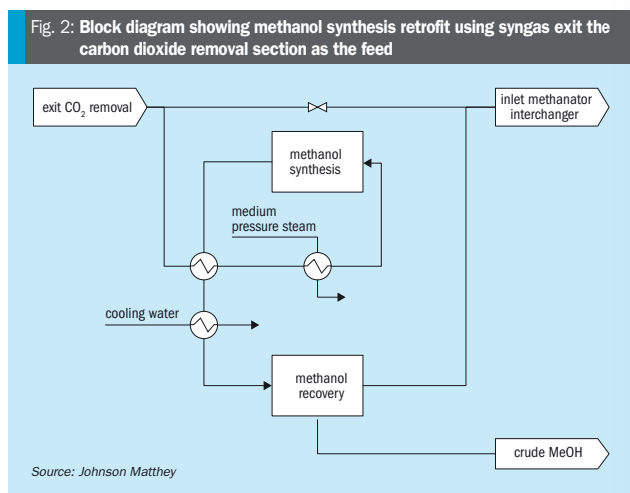

Source: Johnson Matthey

between Johnson Matthey and KBR to license ammonia-methanol coproduction processes combines JM's methanol production process and KBR's proprietary PURIFIER™ ammonia process. KBR's PURIFIER technology provides a method of optimising the syngas composition downstream of the methanol synthesis retrofit.

Collaboration between the technology providers can exploit the synergies between the two technologies and reduce the environmental impact of the plant and its opex through shared utilities and lower energy consumption. The interconnectivities between the processes and the design of the methanol synthesis retrofit in close collaboration with the ammonia technology allows for flexibility to optimise production between ammonia and methanol.

**Coproduction using syngas exit CO<sub>2</sub> removal**

**Flowsheet**

For cases requiring a lower production rate of methanol, the syngas exit the CO<sub>2</sub> removal stage can be used. Here, there are low levels of CO and CO<sub>2</sub> following the shift and CO<sub>2</sub> removal sections, so the maximum methanol capacity is limited. The syngas typically has a water content that is low enough to not require a desaturation stage. The syngas from the overhead of the CO<sub>2</sub> removal column is heated to methanol synthesis temperatures. The CO and CO<sub>2</sub> is converted to methanol in a suitable once-through methanol converter.

**Fig. 3: Effect of production rate of methanol synthesis retrofit installed downstream of CO<sub>2</sub> removal stage on potential ammonia production rate**

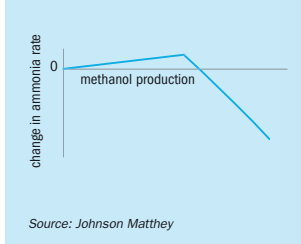

Source: Johnson Matthey

The product methanol is recovered in a crude state and sent to a distillation section for refining to product specifications. The unreacted syngas is returned to the ammonia plant. This is illustrated in Fig. 2.

If there are insufficient carbon oxides in the ammonia plant syngas exit the CO<sub>2</sub> removal stage, but the required production rate is not so high as to make the scheme using syngas inlet the HTS attractive, it is possible to make small modifications to the ammonia plant to increase the methanol production rate.

To increase the CO content exit the CO<sub>2</sub> removal stage, a portion of the plant flow can be bypassed around the low temperature shift (LTS) converter. Alternatively, the operation of the CO<sub>2</sub> removal section can be adjusted to increase the slip of CO<sub>2</sub>.

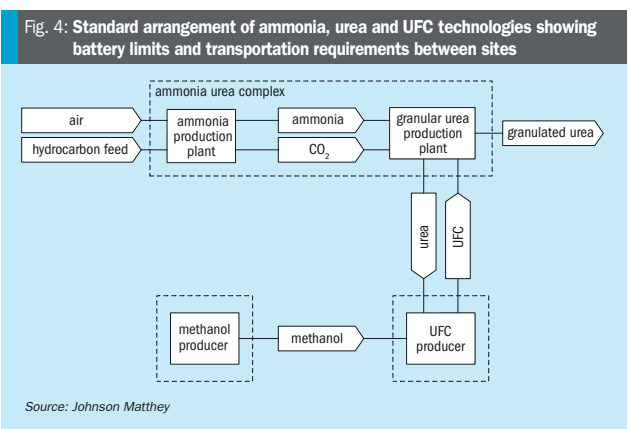

Source: Johnson Matthey

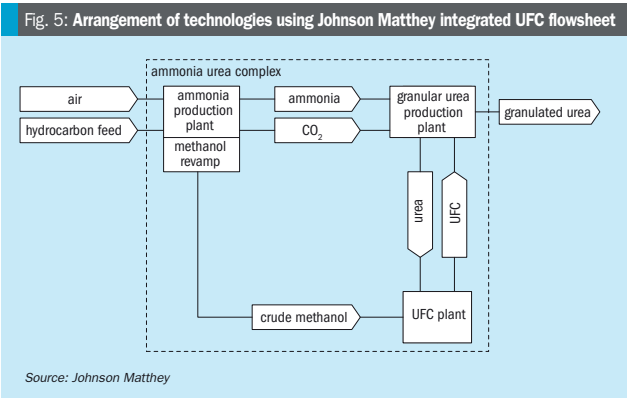

Source: Johnson Matthey

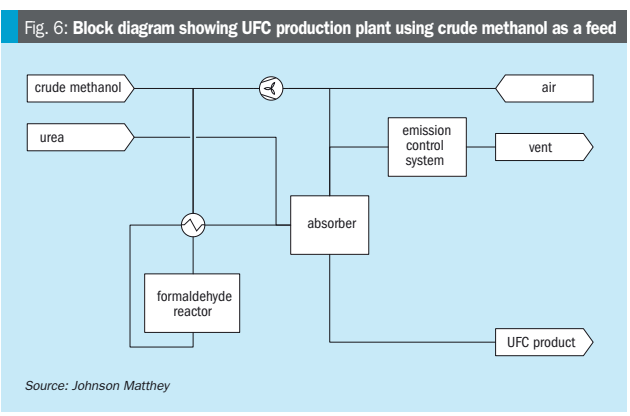

Source: Johnson Matthey

**Advantages**

Benefits of the retrofit in this form are that there is a single break in and return point to the existing ammonia plant and it has little impact on the operation of the existing equipment. The bypass configuration allows for continual operation of the ammonia plant without the methanol section operating and for simple start-up of the methanol section in parallel to the ammonia plant.

Downstream of the CO<sub>2</sub> removal section, the carbon oxides are considered a contaminant since they act as a poison in the ammonia synthesis converter, and carbon dioxide can form ammonium carbamate via reaction with ammonia. Therefore, any carbon oxides in the process are converted to methane in the methanator. The methanation process consumes hydrogen via the reactions:

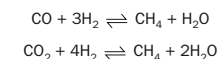

This hydrogen consumed via methanation cannot then be used in the synthesis of ammonia. Since the conversion of CO and CO<sub>2</sub> to methanol consumes less hydrogen than the corresponding methanation reactions, the net effect of introducing the methanol synthesis retrofit is to reduce the hydrogen consumed to convert the residual carbon oxides. This allows for a higher flow rate of hydrogen to the ammonia synthesis section, and if the synthesis loop and associated equipment is capable, allows for an increase in the production of ammonia.

Note that increasing the CO or CO<sub>2</sub> at the feed to the retrofit section via a partial bypass of the LTS or modification of the CO<sub>2</sub> removal section will increase the carbon oxides slip from the methanol synthesis section. These carbon oxides consume hydrogen in methanation and will reduce the potential ammonia production rate. Eventually, the increased slip will offset the benefit on hydrogen consumption of synthesising methanol over methanation (Fig. 3).

The once through system is designed such that operation is as simple as possible, and the plant with the retrofit in place can be operated with existing staffing levels.

For significantly higher required methanol production rates, this illustrates how a retrofit using syngas exit the CO<sub>2</sub> removal stage is less suitable than one using syngas exit the secondary reformer.

**CONTENTS**

What's in issue 368

**COVER FEATURE 1**

The future of DME

**COVER FEATURE 2**

Nitric acid carbon credits

**COVER FEATURE 3**

Revamping ammonia plants

**COVER FEATURE 4**

Plant digital solutions

**NITROGEN+SYNGAS**  
**ISSUE 368**  
NOVEMBER-DECEMBER 2020

**BCInsight**

Southbank House, Black Prince Road  
London SE1 7SJ, England  
Tel: +44 (0)20 7793 2567  
Fax: +44 (0)20 7793 2577  
Web: www.bcinsight.com  
www.bcinsightsearch.com

**Ammonia plant impact**

There is a lesser impact on the ammonia plant for a retrofit using syngas exit the CO<sub>2</sub> removal stage since the methanol synthesis is using a smaller flow of CO and CO<sub>2</sub> than that upstream of the shift section.

As discussed above, there may be a benefit to ammonia production as a result of the methanol synthesis retrofit. For cases requiring higher CO and CO<sub>2</sub> in the feed, the ammonia production may be reduced. Some, or all, of this reduction in rate may be accommodated by uprating the ammonia plant syngas generation section, and an assessment of the optimal technology configuration can be made on a case by case basis in close collaboration with the ammonia technology provider.

A reduced exotherm over the methanator as a result of lower CO and CO<sub>2</sub> levels in the methanator feed means that additional heating will be required to achieve the methanator inlet temperature. The effect of the increase in heating required can be mitigated with collaboration between ammonia and methanol technology providers and the optimal integration of the flowsheets.

**Integrated UFC**

Urea formaldehyde concentrate (UFC) is used to condition a granular urea product and some prilled urea products. UFC is added to the urea product in small quantities, which renders a standalone production facility for an individual urea producer unfavourable economically. Therefore, urea producers typically import purchased UFC from third party distributors (Fig. 4).

UFC producers would normally purchase a methanol feedstock at market value, which includes the margins of the methanol producers. The imported UFC cost also allows for the third-party producer's margins, and the cost of transportation to the urea producer. This raises the opportunity for significant savings to a urea producer were it possible to manufacture the necessary UFC on the ammonia-urea complex.

The interconnectivities between the production of ammonia, urea and formaldehyde can be exploited to offer a retrofit to existing ammonia plants to produce UFC for conditioning the urea product (Fig. 5).

In the iUFC<sup>™</sup> process, formaldehyde is produced via the oxidation of methanol, and methanol can be produced using a retrofit as described earlier. The modest capital costs of a well-designed retrofit section

can allow the savings of in-house UFC production over purchased UFC to be realised.

**UFC production**

Production of formaldehyde and UFC uses well established technologies. The Johnson Matthey FORMOX<sup>™</sup> process employs mixed oxide catalyst technology due to its superior yield, high steam production and because it makes it possible to produce UFC-85 directly in the same plant.

Formaldehyde is produced via the partial oxidation of methanol with air as an oxidising agent:



The product stream from the formaldehyde synthesis reactor is sent to a water absorber column. The formaldehyde is absorbed into the water, the water condensed, and any unreacted air is recycled to the formaldehyde synthesis reactor. A purge stream is taken from the recycle gas which is released to the atmosphere after treatment in an emission control system to convert the trace methanol, formaldehyde and CO to carbon dioxide and water. The formaldehyde in the absorbed water is absorbed into a urea solution to produce a UFC product at the required concentration. This is illustrated in Fig. 6.

**Integrated UFC production**

Standard Johnson Matthey FORMOX<sup>™</sup> plants are designed with flexibility in mind and either UFC-85 or formaldehyde can be produced on the same plant. The plant can also be configured to produce UFC concentrations other than 85%.

When retrofitting an ammonia urea complex for the integrated production of

UFC, the UFC plant can be designed to operate with crude methanol. This allows for capital and operating cost savings in the distillation of the crude methanol product from the methanol synthesis retrofit. Further integration is also possible and can be offered on a case by case basis.

The integration of the UFC plant and the methanol synthesis retrofit on the ammonia plant can integrate the utility requirements to optimise the operating costs of the two processes.

**Benefits**

As discussed above the main benefit of the iUFC process is the reduction in the cost of UFC since the integrated process eliminates the premium of the third-party producer for methanol or UFC and the transport costs. The operating costs for the UFC process are minimal in comparison to the ammonia-urea complex. The potential savings are assessed on a case by case basis and can be maximised by optimising the integration of the iUFC process. Typically, the savings are of the order of the purchase cost of the UFC.

Typically, the required rate of methanol production for an iUFC process means that the methanol synthesis retrofit using the syngas exit the CO<sub>2</sub> removal stage is most appropriate. Therefore, the benefits outlined previously are also applicable here. The flexibility of the methanol synthesis retrofit means that there is no impact on ammonia plant reliability and standard storage designs can be provided for intermediate storage of crude methanol to accommodate catalyst changes in the methanol and formaldehyde synthesis systems. ■

**Johnson Matthey FORMOX**

Johnson Matthey FORMOX has been developing and selling formaldehyde technology and catalysts since the late 1950s and has supplied more than 20 million t/a (as 37 wt-%) capacity to a wide range of customers. To put this into context, global demand in 2015 was about 45 million t/a. By carrying out both catalyst and technology development in the same organisation, any catalyst development can easily be implemented in the flowsheet and vice-versa. Johnson Matthey FORMOX typically acts as an engineering and procurement contractor during the project phase and assists during erection and commissioning. After start-up Johnson Matthey FORMOX continues to support plant operation with an extensive technical support program.

Johnson Matthey FORMOX has continuously improved the formaldehyde catalyst and technology and today its customers produce more than four times as much formaldehyde in the same size reactor as in the early 1960s. This increase in production also comes with a considerably improved yield, less than half the power consumption and more than double the steam generation. ■

**ARVOS / SCHMIDTSCHESCHACK****Improving plant reliability with a new process gas cooler**

Dr. J. Weidenfeller

The steam system in ammonia plants can have a big impact on the overall reliability of the plant. Steam is used at different pressure levels for the process itself, as well as providing the driving power for the process compressors. The steam is produced by waste heat recovery from the process and additional natural gas fired auxiliary boilers. Depending on the plant scenario, modern steam systems are designed for zero steam export, export steam to produce electricity, or in the case of an ammonia/urea complex, to supply steam or electricity to the urea plant, which is a consumer of both.

In ammonia plants, a major part of the steam generation by waste heat recovery takes place downstream of the secondary reformer. The waste heat boiler package, at a minimum, consists of a horizontal or vertical process gas cooler (PGC) with a steam drum, operating with natural circulation of the water/steam. Damage to the PGC is the main cause of poor performance of the steam system and unexpected plant shutdowns.

**Reasons for PGC failures**

Most of the world's ammonia plants built between 1960 and 1990 are equipped with vertical PGCs downstream of the secondary reformer. A typical arrangement is shown in Fig. 1. The effluent gas enters two parallel

Fig. 1: Typical arrangement of vertical primary and secondary PGCs

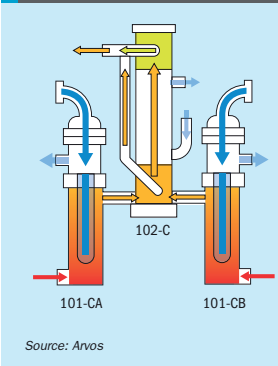

primary PGCs at a temperature level around 1,000°C. The primary PGCs are connected to a vertical secondary PGC. The secondary PGC is equipped with an external by-pass to control the gas outlet temperature.

During the last ten years, reliability issues, damage and failures of both PGCs have been reported in various conference papers.

The primary PGCs (101-CA/CB) have a vertical bayonet water tube type design. The process gas enters at the bottom and flows turned by baffles upwards in co-

current flow with the boiler water (BW). The shell is completely refractory lined on the inside and has a water jacket on the outside. The bayonet tube is a tube-in-tube design; in general this design, with boiler water flowing in the annular gap, is an excellent solution for a heating surface. In the bayonet design the water enters the end cap of each tube through a coaxial open-ended inner tube and flows upwards through the annular space between the inner and outer tube walls. As the inner and outer tubes are held by different tube sheets, the bayonet tube boiler design avoids the critical problem of tube sheet stress caused by thermal expansion of the tubes, which virtually disqualifies conventional shell-and-tube designs for this application.

However, the bayonet tubes of the PGC have several inherent reliability issues, in particular:

- Sludge deposition in the end cap/pocket of the bayonets: deposits in the BW agglomerate in the end cap and reduce or inhibit the cooling capability. In addition, the cap is the section of the bayonet with the highest heat flux and consequently this leads to local overheating. The situation gets worse when operating above the nameplate capacity.
- Tube vibration: since the process gas is turned by baffles, there is always the risk of flow induced tube vibrations and tube failure.

Fig. 2: Schmidt'sche® double tube system

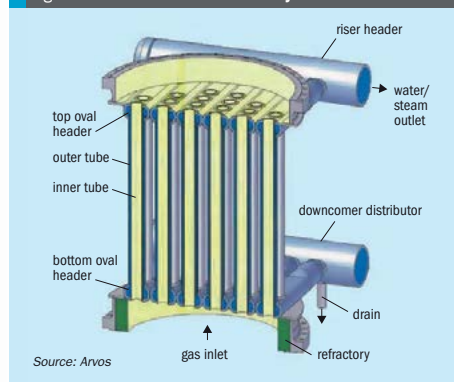

Nitrogen+Syngas 368 | November-December 2020

Fig. 3: Comparison of gas partial pressures in ammonia vs coal gasification plants

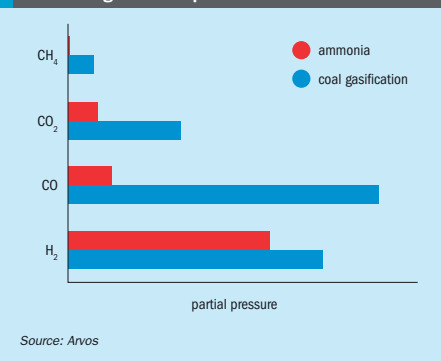

Source: Arvos

www.nitrogenandsyngas.com

**CONTENTS**

What's in issue 368

**COVER FEATURE 1**

The future of DME

**COVER FEATURE 2**

Nitric acid carbon credits

**COVER FEATURE 3**

Revamping ammonia plants

**COVER FEATURE 4**

Plant digital solutions

NITROGEN+SYNGAS  
**ISSUE 368**  
NOVEMBER-DECEMBER 2020

**BCInsight**

Southbank House, Black Prince Road  
London SE1 7SJ, England

Tel: +44 (0)20 7793 2567

Fax: +44 (0)20 7793 2577

Web: www.bcinsight.com

www.bcinsightsearch.com



- Problems during start-up since the direction of the water/steam circulation are not clearly defined.

Damage to the tube bundles of these boilers is the main cause of unexpected shut-downs in ammonia plants. The boiler is high maintenance with the tube bundle needing frequent replacement. This requires a spare bundle that also has to be maintained ready for the next replacement. Spare inventory also ties up capital with additional negative financial impact.

The secondary PGC (102-C) is a standard shell-and-tube in a vertical fire tube design. The process gas enters the PGC at the bottom and flows upwards in co-current flow with BW. As already discussed, this design principle has inherent reliability issues due to sludge deposition at the lower tube sheet, which can lead to overheating and failure of tube-to-tube sheet welding, and steam blanketing at the upper tube sheet. Due to mechanical reasons, riser nozzles cannot be located as close to the upper tube sheet as required. Consequently, steam bubbles agglomerate which leads to reduced cooling of the upper tube sheet and failure of tube-to-tube sheet welding.

A reliable design of a vertical PGC is always challenging. For that reason Schmidtsche Schack's philosophy was not to develop a completely new design, but to apply and adapt a proven design to achieve a reliable solution.

### A proven design

The basic element of this proven solution is the Schmidt'sche® double tube system (see Fig. 2). It combines the advantages of the fire and water tube design and comprises a row of coaxial double tubes welded at each end to a horizontal header with an oval cross-section. A PGC is made up of a multiple array of these tube/header assemblies, with the headers welded together to effectively form hollow tube sheets.

The water side of the exchanger operates in natural circulation. Water from the steam drum is fed through the downcomer piping to the bottom oval headers and flows upwards through the annulus between the inner and outer tubes, where it is partially converted to steam, and into the upper headers, which discharge into the riser manifold. As the 'tube sheets' are cooled by the water/steam flowing through the tube headers, there is no need to protect the tube sheet with a refractory layer. This reduces the use of refractory and has a positive effect on the reliability of the PGC and plant.

The process gas flows through the inner tubes and is cooled by the water/steam mixture in the annulus between the inner and outer tubes.

Each process tube in the Schmidt'sche® double tube exchanger thus has its own

cooling element provided by the outer tube. Variations in the heat load on the individual tubes are automatically accommodated by the proportion of the water that is converted to steam.

Due to the clearly defined flow path on the water side and on the gas side there is no risk of flow induced vibrations.

Since the BW flow from bottom to top is clearly defined, on the one hand there is no risk of sludge settlement at the bottom or steam bubble agglomeration at the top. On the other hand, the direction of natural circulation is predetermined during start-up.

High water flow velocities with high turbulence intensively cool the oval headers (tube sheet) and each tube. Consequently, a reduced wall thickness can be realised which leads to lower wall and material temperatures. This results in low thermal stresses at the tubes and tube-to-tube sheet welding. In addition, the oval header, a key design feature, enables easy accommodation of differential thermal expansion between the inner and outer tube, which also results in favourable stress patterns.

The robustness of the Schmidt'sche® double tube system is ensured by full penetration and crevice free welds of the inner and outer tube. Crevice corrosion is therefore avoided and due to water cooling at the weld position, the temperature at the welds is low.

Fig. 4: Use case for 101-CA/CB one by one replacement

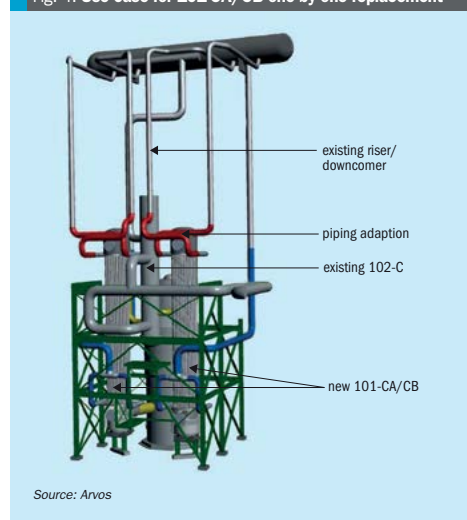

Source: Arvos

Fig. 5: Use case for 101-CA/CB replacement by one big PGC

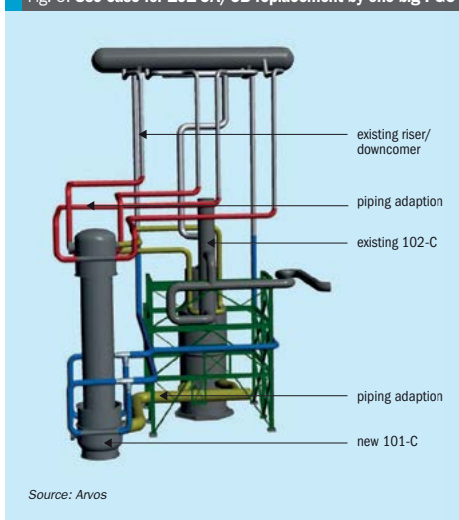

Source: Arvos

### Reference applications

The vast majority of Schmidt'sche® double tubes systems are used in the petrochemical industry in steam cracking processes for olefin production. However, in the last 20 years approximately 19 units of double tube heat exchangers have also been installed downstream of the gasifier in coal, pet-coke and biomass gasification processes, where the syngas atmosphere is more severe than in ammonia plants. Gasification plants are more problematic than ammonia plants and experience higher fouling, higher metal dusting and higher hydrogen attack due to the higher partial pressures of hydrogen, carbon monoxide and carbon dioxide as shown in Fig. 3.

The process conditions, as well as the size and weight of the double tube design, for replacing 101-CA/CB in a typical ammonia application are within the existing experience of ethylene and gasification plants.

### Revamping options

The boilers downstream of the secondary reformer (101-CA/CB and 102-C) can be replaced in three different scenarios:

- One-by-one: each of 101-CA/CB and 102-C can be replaced by a new PGC.
- Two-in-one: both 101-CA/CB will be replaced by one big 101-C. 102-C will be replaced separately. The existing by-pass for temperature control also remains.
- Three-in-one: all three boilers will be replaced by one big PGC including temperature control.

The greatest customer benefit is achieved by a one-by-one replacement for the following reasons:

- Usually the existing foundation inside the existing steel structure is suitable for the new PGCs (preliminary analysis can assess this issue); the installation of a new big foundation will be avoided.
- No additional plot space for the new PGC is required (which would reduce the available space for maintenance activities).
- The existing gas transfer lines can be used; the installation of a new long and big transfer line connecting the secondary reformer to the new big PGC is expensive and could be a safety concern due to operation at high pressure and temperature.
- The existing water/steam piping can be used with minimal adjustments. In case of a new big PGC this piping has to be considerably extended.

Fig. 4 shows an example of the one-by-one replacement of 101-CA/CB. The new 101-CA/CB was designed for 2,000 t/d, a capacity upgrade from nameplate capacity (1,360 t/d). The real arrangement of an existing plant was 3D laser scanned by Casale SA. The data were transferred into a CAD model. This approach ensures full transparency in the design phase and allows any issues to be detected early in the project phase.

The new PGC fits into the existing steel structure on the existing foundation. Adjustments to the existing riser/downcomer piping are very limited (coloured red/blue).

The double tube technology is flexible enough for all revamping scenarios depending on customer needs and requirements. Fig. 5 shows an example of the replacement of the 101-CA/CB with one PGC. The major extensions of water/steam piping as well as the gas transfer line can be clearly seen. In this case, the new PGC requires a new plot space outside the existing steel structure.



With our customized solutions for heat recovery applications we meet the highest demands of your process.

- In-house Development and Manufacturing
- Reliable & Proven Design Features
- Revamp & Upgrade Projects
- 24/7 - Service-Support

All with the goal to enhance the efficiency of your production plant.

Discover our share at:  
[www.schmidtsche-schack.com](http://www.schmidtsche-schack.com)

### CONTENTS

What's in issue 368

### COVER FEATURE 1

The future of DME

### COVER FEATURE 2

Nitric acid carbon credits

### COVER FEATURE 3

Revamping ammonia plants

### COVER FEATURE 4

Plant digital solutions

NITROGEN+SYNGAS  
**ISSUE 368**  
NOVEMBER-DECEMBER 2020

**BCInsight**

Southbank House, Black Prince Road  
London SE1 7SJ, England  
Tel: +44 (0)20 7793 2567  
Fax: +44 (0)20 7793 2577  
Web: [www.bcinsight.com](http://www.bcinsight.com)  
[www.bcinsightsearch.com](http://www.bcinsightsearch.com)

# Digital solutions bringing better performance

By harnessing the power of real-time data and exploiting the opportunities provided by digital solutions plant owners can achieve greater plant efficiency and reliability. In this article Stamicarbon shows the benefits of the Stami Digital Plant Optimiser for urea plants, OnPoint Digital Solutions provides a case study on optimising primary reformer heater operations using Smart Combustion™, TOYO provides an update on its digital transformation service DX-PLANT® and thyssenkrupp Industrial Solutions provides examples of how digital solutions can be used to improve plant operation.

## Urea operation with the Stami Digital Plant Optimiser

For a urea plant, achieving operational excellence means making optimal use of available resources and process equipment. Stamicarbon, the licensing and innovation centre of the Maire Tecnimont Group has always been on the forefront of developments and innovations, helping urea producers to improve plant performance and maximise production.

The following sections describe the Stami Digital Plant Optimiser that monitors and optimises the operation of the urea plant every minute, hour and day, providing urea producers with enhanced reliability of operation by ensuring continuous and consistent best-practice operation<sup>1</sup>.

### Interaction between the variables

All urea stripping plants are characterised by a high degree of interaction among the process variables. Any change at the back end will affect the synthesis and vice versa. These are typical control characteristics for plants incorporating multiple recycles. The dehydration of ammonium carbamate to urea and water is slow, which requires large retention times in the reactor (typically one hour). This reactor hold-up is characterised as a "pure dead time" in the process. Dead time is the property of a physical system by which the response to an applied disturbance is delayed in its effect.

The Stami Digital Plant Optimiser combines the benefits of a multivariable, model-predictive control (MPC) system with the non-linear optimisation capability of Stamicarbon's urea process modelling

tool. It uses a model of the urea process to predict the behaviour of the plant in the foreseeable future (typically several hours ahead). Knowing what the safety and operating limitations and the quality specifications of the process are, it will calculate the optimal adjustments to be made to the process, and implement these adjustments, by sending small changes to the setpoints of key process variables in the distributed control system (DCS). This provides urea producers with improved reliability in operation by ensuring continuous and consistently optimal operation.

### Optimiser description

The basic principle of an MPC system is to use knowledge of the process transfer characteristics. Understanding the relations between manipulated variables, measured disturbances and controlled variables, the process can be continuously feedforward driving to the desired operating conditions. Using data-driven dynamic models derived from step-testing, the MPC controller stabilises the process operation and pushes it as close as possible to process limits, e.g. synthesis pressure. The Stami Digital Plant Optimiser builds upon the Stami Digital Process Monitor (see *Nitrogen+Syngas* May-June 2020)<sup>2</sup> that calculates key performance indicators (KPI's) such as the plant load, ammonia emission and energy consumption and soft sensor key variables. These soft sensor key variables provide additional process information which is not measured or cannot be measured, such as stripper tube load and efficiency or ammonia emission. These soft sensor key variables have been included in the MPC design as control objectives.

The Stami Digital Plant Optimiser directly anticipates the effects that disturbances have on the process outputs that are controlled as soon as these disturbances are observed. It then directly steers the process to new operating conditions. On the contrary, a traditional feedback control system like a PID controller first needs to observe the effects of disturbances at the controlled process outputs before it can start counteracting these disturbances. In some cases, e.g. reactor N/C-control, it takes a while before the effects of disturbances on the controlled process outputs can be measured.

Without the Stami Digital Plant Optimiser, corrective actions are left to the decision and discretion of the operators, while the Stami Digital Plant Optimiser automates operator handling and drives the urea plant to an optimised operating point by including real-time optimisation (RTO) and MPC as shown in the architecture of the Plant Optimiser system (Fig. 1).

The plant model is configured as a soft sensor which generates key variables, but also as a real-time optimiser. Optimal conditions for the process at steady state are determined by the RTO, while the trajectory to be followed as predicted with the use of a linear dynamic model, obtained through a plant step test is done by the MPC. Due to the typical complexity (high degree of interactions and recycles) of a urea plant, the MPC is the perfect tool to reach the optimal, stable operating point in a straightforward way.

Once the desired stability is reached, the MPC will be used to smoothly maximise the CO<sub>2</sub> flow without violating any of the

Fig. 1: Architecture of the Stami Digital Plant Optimiser system

Source: Stamicarbon

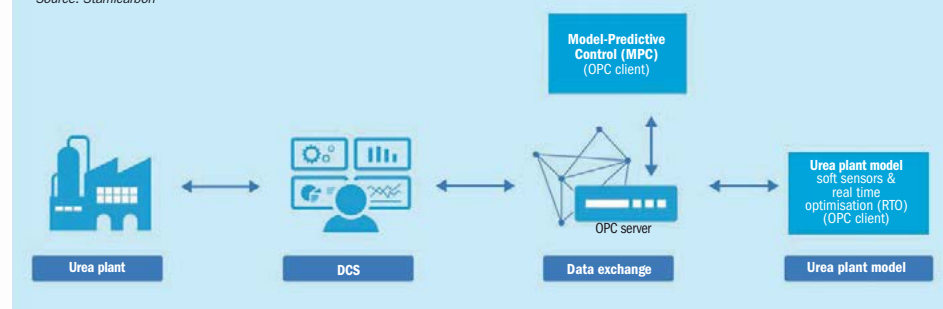

operating constraints, securing maximum attainable production capacity at any time.

### Client experiences

A successful Plant Optimiser project has been executed on a urea plant with Stamicarbon's Launch Melt™ pool reactor design, which currently runs at a capacity of 1,400 t/d. The client was searching for opportunities to improve the operation of the urea plant without having major hardware changes. The Stami Digital Plant Optimiser was selected as the optimisation tool. This urea plant is highly integrated with two melamine plants and an ammonium nitrate plant, providing additional challenges to the project due to its complexity. The project brought a lot of experiences and best practices to the benefit of all involved parties:

### Current operation is not always optimal

The first lesson learnt was that a plant model is as smart and accurate as you make it! Since the urea plant has a large operating window, the model needed to be programmed in a robust way to cover all the operating cases. The validation of the plant model with historical data which was done using Stamicarbon's Advance Consult™ system, revealed unexpected surprises. At some points, the model predictions and trends deviated from the client's own experiences and practices. This led to several discussions between the process engineers of the client and Stamicarbon. In this phase it became clear that the urea plant was not operated in the optimal way. Based on the outcome of these discussions the client was able to increase its urea production. For the client this was a very valuable period in the project, as it was already paying off before it was implemented.

### Implementation can take time

It turned out that the implementation phase of this project took longer than expected. This was due to three main reasons. First of all, the difference in opinion of the process engineers on optimal operation took time. Secondly, some critical instruments were not functioning properly which effected the implementation of the control strategy in the MPC controller. Finally, in order to perform the step tests, the plant should be operated at nominal conditions. Planning of the right resources available, combined with the right plant condition was more complex than was foreseen.

### Optimisation can be a repeat process

If at a later date the plant operation changes, because of a debottlenecking project for example, the plant model and the dynamic model from the MPC will need to be adjusted. Consequently, certain step testing might need to be repeated facing the same constraints as described above.

### Results

The Stami Digital Plant Optimiser calculates the ideal N/C-ratio in the pool reactor on which the MPC anticipates. Because of an improved yield in the reactor, the total production capacity increases. Also important to realise is the reduction in variations on the N/C-ratio once the optimiser is switched on. The stripper tube load is continuously calculated by the plant model, and the specific energy consumption is lowest at maximum tube load. The stripper tube load is configured as a constraint in the MPC, meaning a certain value may not be exceeded. The MPC nicely steers to maximum value.

For the above-mentioned project the Stami Digital Plant Optimiser realised a

4% production increase and a significant decrease of the energy costs. The results achieved by implementing the Stami Digital Plant Optimiser exceeded expectations; not only in plant performance, but also in the knowledge gained.

An optimisation criterion might be to maximise load or, given constraints in feedstock, minimise energy consumption or some other objective function. Using the process model for plant optimisation becomes powerful when used in conjunction with an MPC. The implementation of the Stami Digital Plant Optimiser does not require any hardware changes, nor does it require a plant shutdown. The extension is limited to software only.

Typical benefits from the Stami Digital Plant Optimiser are a 1% to 5% increase in production, a 1% to 3% decrease in specific energy consumption, a higher on-stream factor and more hands-off operation due to the decreased interventions by operators.

The Stami Digital Plant Optimiser is part of the Stami Digital Product Suite which currently includes:

- Stami Digital Training Simulator; for training panel operators, field operators and plant staff engineers on all urea melt and urea granulation plant operations.
- Stami Digital Soft N/C Meter; for calculating the N/C ratio without the need for a hardware-based N/C meter.
- Stami Digital Process Monitor; for providing KPIs and soft sensor key variables dash board information enabling the operators and plant engineers to better control and optimise their urea plant.

In line with Stamicarbon's digitalisation strategy further digital products are on their development roadmap.

## CONTENTS

What's in issue 368

## COVER FEATURE 1

The future of DME

## COVER FEATURE 2

Nitric acid carbon credits

## COVER FEATURE 3

Revamping ammonia plants

## COVER FEATURE 4

Plant digital solutions

NITROGEN+SYNGAS  
ISSUE 368  
NOVEMBER-DECEMBER 2020

BCInsight

Southbank House, Black Prince Road  
London SE1 7SJ, England

Tel: +44 (0)20 7793 2567

Fax: +44 (0)20 7793 2577

Web: www.bcinsight.com

www.bcinsightsearch.com

## Optimising fired heaters with Smart Combustion™

Primary reformer fired heaters are complex systems that are challenging to operate and optimise without substantial, direct operator oversight and involvement. Generally, there is limited real-time operational combustion information readily available to proactively identify combustion related problems or effectively optimise combustion operations. This means that site personnel must expend significant time and effort to monitor operations and assess operational issues such as flame impingement, burner tip plugging and temperature imbalances.

OnPoint's Smart Combustion digital solutions solve these problems by utilising information from existing process heater instrumentation in real time analysed with proprietary, equipment specific combustion calculations to provide combustion insights and targeted recommended operational adjustments to plant personnel to optimise heater combustion performance resulting in decreased emissions, improved reliability and safety and increased efficiency and heater throughput<sup>3</sup>.

### Steam methane reformers

Steam methane reformers are generally large, rectangular heaters with multiple types of burners installed in different locations around the unit. The majority of the heat input into the reformer comes from the roof of the furnace and installed in rows between rows of process tubes. This is illustrated in Fig. 2. A typical reformer has 100-200 arch burners. The air flowrate to individual burners can typically be controlled by manually adjusting air register settings. However, the fuel flow is typically only controlled by global or zonal control valves. This can lead to imbalances with individual burner fuel to air ratios resulting in poor combustion performance.

Each burner will generally have an isolation valve installed upstream of the burner that should only be used to turn burners on or off. However, some operators will attempt to use these valves to throttle the fuel to individual burners. This is not recommended as this causes an adverse redistribution of the remaining fuel to other burners that can result in fuel maldistribution, un-even heating and unsafe operating conditions.

Burner design considerations which are important in a steam methane reformer are flame length and air momentum relative to

Fig. 2: Typical down-fired reformer

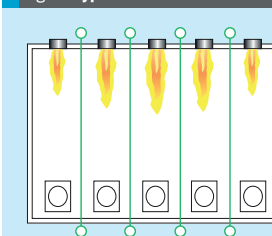

Source: OnPoint

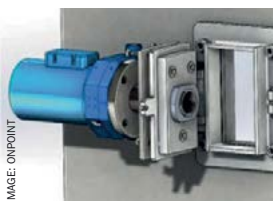

Fig. 4: ZoloSCAN sight port retrofit.

other burners. It is common for these heaters to be operated with either induced or balanced draft systems with preheated combustion air. Balanced draft systems create a challenge to optimise as the duct work from the forced draft fan to each individual burner needs to be designed so that all burners get equal air distribution to ensure proper combustion can be maintained. Typically, plant constrains do not allow an optimum duct design, resulting in maldistribution of combustion air to the burners.

### Ember™

Ember is a cloud-based, digital tool which takes real-time data collected from existing instrumentation recorded in the site historian, analyses it in specifically derived physics-based models and returns operational insights and burner adjustment recommendations back all in just a few seconds. These insights and recommendations can be used by operators or plant engineers to make prioritised, targeted adjustments to individual burners to improve operations to a desired target objective. Iteration is no longer required to find the right set point. Ember tells you exactly how to adjust and set the burners the first time for specific operating conditions.

Some of those insights include burner-by-burner stoichiometry, recommendations for how to set air registers and even can advise how much your gas tips are plugged so that

Fig. 3: ZoloSCAN installation

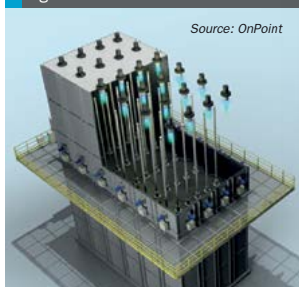

Source: OnPoint

Fig. 5: ZoloSCAN layout

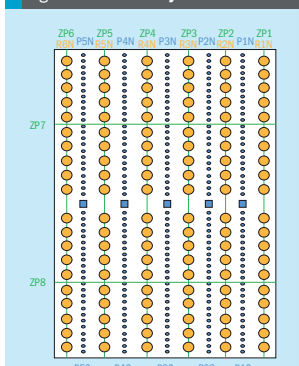

Source: OnPoint

proactive rather than reactive maintenance can be done. The Ember app also combines all the burner performance information together to give you an overall efficiency score of the heater. When Ember is installed on multiple heaters, comparing Ember outputs allows for you go to focus on the areas with the biggest opportunity in real-time. As soon as an operator logs an air register change, the system will update, giving instant feedback the actions you are taking make a real difference inside your facility. The Ember mobile app also provides a platform to take pictures and record notes about individual burners for maintenance or other reasons.

### ZoloSCAN

ZoloSCAN is a laser-based measurement system which can be used to monitor temperature, oxygen, CO, methane, and water inside of the firebox. Its fibre coupled architecture allows for multiple paths and

Maire  
Tecnimont

## WE KNOW OUR WAY AROUND ENGINEERING

Think about thousands of highly skilled professionals with distinctive competences and technological know-how operating in the hydrocarbon processing sector.

Petrochemicals, oil&gas refining and fertilizers are our core industries, while we aim at accelerating the world energy transition through low carbon technologies and green chemistry.

This is **Maire Tecnimont Group**: a plant engineering leader focused on the chemical processing of conventional and renewable energy resources into advanced products embedded in everyday life.

45  
COUNTRIES

~1500  
TOTAL DELIVERED  
PROJECTS

50  
COMPANIES

www.mairetecnicmont.com



CONTENTS

What's in issue 368

COVER FEATURE 1

The future of DME

COVER FEATURE 2

Nitric acid carbon credits

COVER FEATURE 3

Revamping ammonia plants

COVER FEATURE 4

Plant digital solutions

NITROGEN+SYNGAS  
ISSUE 368  
NOVEMBER-DECEMBER 2020

BCInsight

Southbank House, Black Prince Road  
London SE1 7SJ, England

Tel: +44 (0)20 7793 2567

Fax: +44 (0)20 7793 2577

Web: www.bcinsight.com  
www.bcinsightsearch.com

Fig. 6: Burner stoichiometry map before Ember tuning

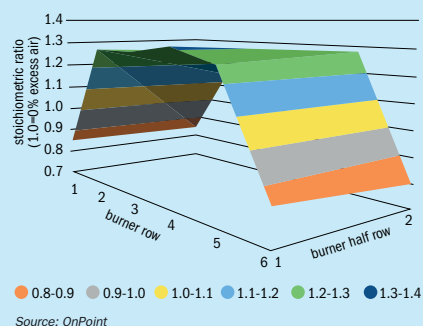
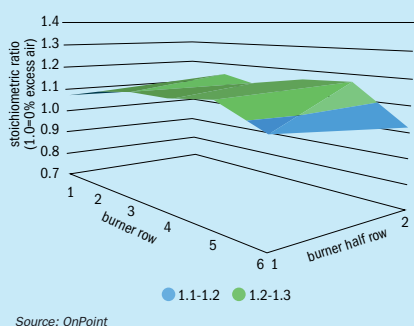

Fig. 8: Burner stoichiometry map after Ember tuning



zones to be sampled from a single system (see Fig. 3). The system can be installed while the heater is online using our innovation sight port retrofit kit. This kit replaces existing view or sight ports with a bolt on assembly which retains the same viewing capability as before but adds a mounting for the SensAlign™ head (see Fig. 4).

The data from ZoloSCAN can be used to provide a more granular view of combustion operations inside the heater by essentially dividing it into zones. These measurement zones can then be compared to one another as well as against the operating setpoint so targeted actions can be taken to optimise combustion and heater performance.



Fig. 7: Outer lane burners before Ember tuning.



Fig. 9: Outer lane burners after Ember tuning.

### Case study

Before applying Smart Combustion, a user was experiencing a large variation in their coil outlet temperatures and observed poor combustion performance, long lazy flames, and flame impingement on process tubes leading to premature catalyst deactivation and accelerated process tube failure. A holistic solution of Ember and ZoloSCAN were used on this unit to troubleshoot and solve the combustion related issues the customer was experiencing.

Before installing ZoloSCAN, the site had temperature, oxygen and CO analysers at the exit of the radiant section. This allowed for a global overview of products of combustion but without the ability to identify imbalances of temperature, regions of high or low oxygen and the origin of CO across the heater if global excursions were observed. The addition of ZoloSCAN allowed OnPoint and the user to see flue gas temperature and oxygen measurements in each burner lane, giving a more

granular view of combustion operations (see Fig. 5). The ability to monitor CO in each burner lane also allowed the operator to troubleshoot high CO readings more quickly, a typical indicator of poor or unsafe combustion.

Installing Ember gave OnPoint and the user a burner-by-burner view of the combustion performance inside the heater. An Ember deployment consists of developing air and fuel side physics-based models using detailed dimensional and operational information of the reformer, burners and forced draft duct work inside a Computational Fluid Dynamic Analysis and other proprietary tools. These models provided new real-time, combustion related outputs which were not previously available and used for validation of existing instrumentation.

In general, process burners inside the same fired heater are designed to be operated at the same excess air/stoichiometry to promote equal combustion and there-

fore heat transfer across the reformer. As you can see from the graph in Fig. 6, the actual operation was much different.

This graph illustrates a map of excess air across the entire reformer. Each number on the x-axis, (band of colours) represents a row of burners. This particular reformer had the ability to modulate fuel to each burner half row and an average of the excess air across this half row is indicated on the graph. The legend explaining the colours indicates a range of burner stoichiometry. As you can see from the figure, the middle part of the reformer was very high on excess air (as high as 30-40% excess air) and the outer rows of burners were operating substoichiometrically (as low as -20% of the required theoretical air), or below the minimum required amount of air needed for complete combustion. Since only a single oxygen analyser was installed at the exit of the radiant section, this burner stoichiometry imbalance was

not evident as the products of combustion mix and became more uniform 1-2% excess global oxygen by the time they exit the radiant section.

Inside the furnace, combustion concerns such as bushy flames, longer than expected flames and visible flames rolling into the process tubes (see Fig. 7) were observed. Understanding the specific changes to individual burner settings to solve these problems requires real time operational data from the furnaces and a deep understanding of the physics behind how the burners work.

Using measurements from furnace instrumentation and ZoloSCAN combined with the outputs from Ember, OnPoint and the site worked together to identify the root cause of the issues they were experiencing and correct the issues by adjusting individual burner dampers using the Ember recommendations.

Fig. 8 illustrates the excess air plot across the entire radiant section of the reformer after implementing the burner adjustment recommendations from Ember. The oxygen distribution is more uniform and no burners were operating substoichiometrically. The global oxygen level remained the same as before. A picture of the same burners after tuning is shown in Fig. 9.

### Results

Installing and utilising the Smart Combustion digital solution resulted in several operational improvements the site was able to capitalise on. Balancing the oxygen created a better temperature balance across the box which led to improved heat

transfer. This resulted in more uniform coil outlet temperatures and eliminated localised hot spots which were present previously. Elimination of localised hot spots increases tube and catalyst life allowing the unit to capture increased production days between outages. The additional data obtained by ZoloSCAN combined with the combustion insights and recommendations from Ember sensors also allowed for faster and safer furnace start-ups.

The site was able to realise \$350,000/year in fuel savings alone from better utilisation of the heat inside of the furnace without increasing the firing rate. The changes also allowed the site to increase throughput up to 7% to take advantage of market conditions. The site now has the real time data and digital tools to keep the reformer in its optimised state at all times, even as process variables change.

### TOYO adds new services and digital solutions to DX-PLANT®

In 2016, Toyo Engineering Corporation (TOYO) launched a digital transformation service named DX-PLANT® for chemical and industrial plants by leveraging IoT and big data analysis technology. DX-PLANT® provides unique solutions focused on: Engineering (E), Operations (O), Maintenance (M) and Business (B) for maximum benefit to TOYO's plant owners (Fig. 10). TOYO takes pride in realising the "digital twin" of a real plant using DX-PLANT® which has been reported in previous issues of *Nitrogen+Syngas*<sup>4,5,6</sup>.

This article addresses the latest updates to TOYO's digital solutions.

Fig. 10: DX-PLANT® architecture

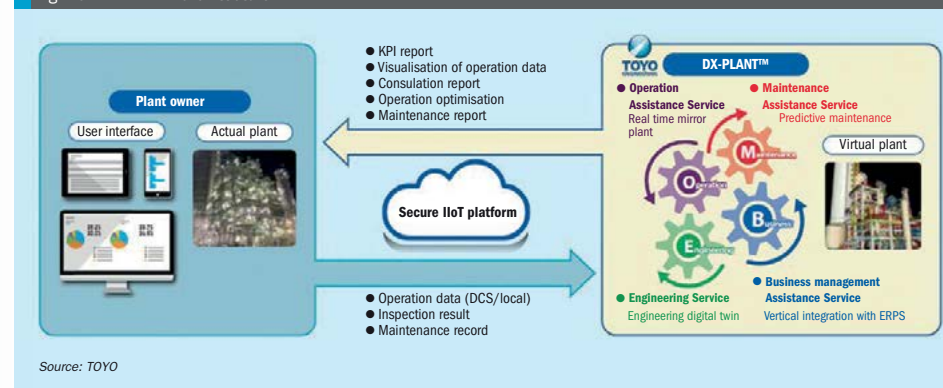

### E: Engineering / information management system

For efficient operation and maintenance of an industrial plant, various information such as engineering documents, maintenance records and/or inspection records should be made available in a timely manner, at any time. TOYO's DX-PLANT® provides a unified information management platform, which enables users to access asset information through a 3D model, P&ID, operation dashboard, etc. (Fig. 11), as well as creating a user interface that appeals to the human five senses, instead of conventional textual information on paper, and makes it easy and intuitive to obtain the required information. Examples of the solutions include:

- AR (augmented reality) / VR (virtual reality) and smart glasses that appeal to the sense of sight;
- voice recognition that appeals to the auditory sense; and
- speech synthesis/smart speakers and haptic technology that appeal to the sense of touch.

The concept of TOYO's smart speaker was reported in the July-August 2020 issue of *Nitrogen+Syngas*<sup>6</sup>.

### O: Operations/PMOS™ & ADVIDA™

In addition to real-time condition monitoring, such as key performance indicators (KPIs) and status diagnoses from a remote location, DX-PLANT® provides operation services around the clock with live specialists on duty. TOYO's innovative new services (PMOS™/ADVIDA™) relating to remote process monitoring are introduced below.

### CONTENTS

What's in issue 368

### COVER FEATURE 1

The future of DME

### COVER FEATURE 2

Nitric acid carbon credits

### COVER FEATURE 3

Revamping ammonia plants

### COVER FEATURE 4

Plant digital solutions

NITROGEN+SYNGAS  
ISSUE 368  
NOVEMBER-DECEMBER 2020

BCInsight

Southbank House, Black Prince Road  
London SE1 7SJ, England

Tel: +44 (0)20 7793 2567

Fax: +44 (0)20 7793 2577

Web: www.bcinsight.com  
www.bcinsightsearch.com

Fig. 11: Information management system

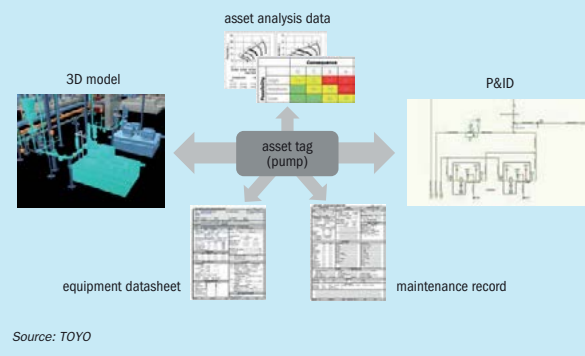

Source: TOYO

Fig. 12: PMOS™ benchmark function

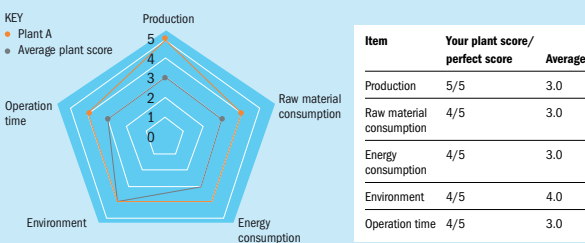

Source: TOYO

Fig. 14: Overall configuration of PMOS™

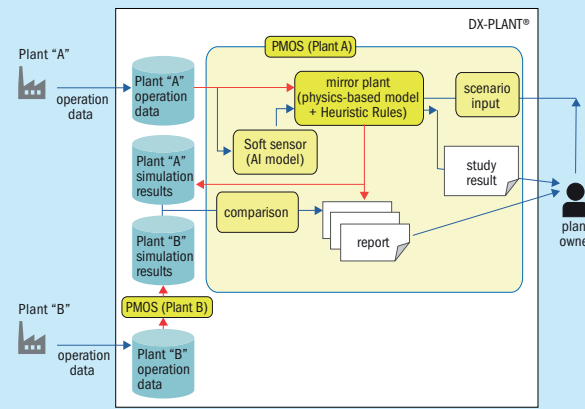

Source: TOYO



Fig. 13: Central monitoring room in TOYO's headquarters.

**PMOS™**

Some plant operation data, such as fluid composition and equipment performance, are not continuously monitored by the DCS (Distributed Control System). Conventionally, the fluid composition was carefully analysed by a laboratory and equipment performance was calculated by a process engineer at great effort. However, these conventional methods take time before the real state of the plant is known, making the plant prone to delayed decision making when there are problems. TOYO, therefore, developed the remote service named PMOS™ (Plant Monitoring & Optimisation System) to realise the creation of the actual state of a plant virtually based on the operation data acquired through DX-PLANT®. This newly developed PMOS™ consists of two functions: monitoring and optimisation.

The monitoring function is a kind of remote supervision from TOYO's headquarters based on real-time analysis utilising TOYO's unique process simulator with expert algorithms. This remarkable service creates not only the actual operational condition in the cloud by reference to real-time DCS data but also automatically generates technical reports (daily and monthly) describing the real material balance, heat balance and critical equipment performance. The report also includes benchmarking, showing how the plant performance with regard to opex and environmental emissions compares to other plants (Fig. 12). With this guideline, plant owners can better understand their ranking against others and endeavour to improve their performance, if required, through TOYO's support. The central monitoring room for this service was set up in TOYO's headquarters for timely supervision and its live experts have monitored the real-time PMOS™ data of TOYO's urea plants around the world (Fig. 13).

Fig. 15: ADVIDA™ showing anomaly symbol

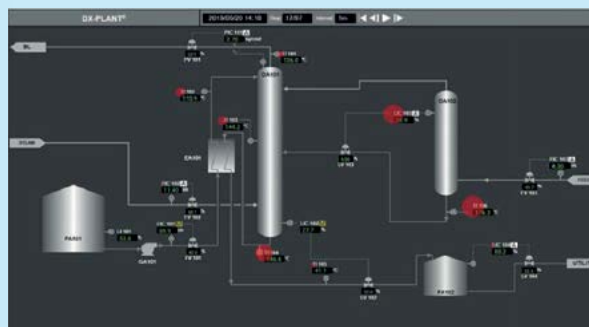

Source: TOYO

Fig. 16: On-line website service of spare parts

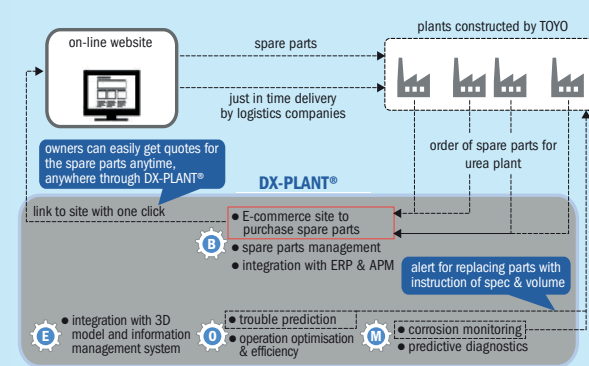

Source: TOYO

Meanwhile, the optimisation function studies all kinds of scenarios to help plant owners operate their plants under optimised operating conditions. For example, the ammonia to CO<sub>2</sub> molar ratio (N/C) in the synthesis section of TOYO's urea plant can be changed virtually allowing the plant operator to evaluate the new performance compared with the present condition (Fig. 14).

**ADVIDA™**

ADVIDA™ (Advanced Data-driven Visual Indication, Detection and Alert) is a refined anomaly diagnosis tool, developed to help DCS operators predict anomalies before

they become too severe. TOYO focused on the following issues faced by plant owners:

- impractical, excessive number of items on DCS operators' watch list;
- difficulty of high and low alarm setting to detect early-warning signs in a timely fashion.

This tool provides a visual symbol on the process graphics enabling DCS operators to grasp the magnitude of an anomaly compared to normal state at first glance. The size of the symbol varies depending on the degree of the anomaly (Fig. 15). By using this visual method, DCS operators are able to spot the anomaly in advance of normal alarm activation. In addition, the system is

equipped with a replay function to view past events on demand. The facility to readily reproduce past events makes this tool suitable for training purposes, to educate and train young operators to analyse a time-series transition of events.

**M: Maintenance/rotating machinery**

Monitoring the performance of rotating machinery is considered essential, because deterioration of the performance will be directly linked to production loss with high repair costs. Usually, large compressors are equipped with a machine monitoring system (MMS) with a sensor ring which provides vibration analysis within one minute. In fact, an anomaly prediction system is provided by MMS manufacturers as standard; however, the function of the manufacturer's system is limited to monitoring only the rotating machine itself, which means it cannot cope with a case where an anomaly happens due to factors outside of the machine. Therefore, overall monitoring covering outside the machine, which links up with the state of the machine, is indispensable. TOYO recognises its significance and has started the development of digital solutions with several manufacturers to address this issue.

**B: Business/on-line spare parts procurement service**

TOYO has recently launched a new service on DX-PLANT® supplying plant owners with spare parts for TOYO's urea process. Plant owners typically spend a lot of time communicating with vendors with enquires for the procurement of spare parts using time-consuming procedures and paperwork. To make things quicker and simpler, a new service has been developed and is about to start which enables plant owners to contact manufacturers of spare parts directly through DX-PLANT® and to complete the procurement process intuitively and simply by referring to the image of spare parts on a platform, similar to shopping on Amazon. This new online service will completely eliminate conventional time-consuming communications spent on requests for quotations (RFQ) or purchase procedures for spare parts. TOYO envisages that just-in-time delivery of spare parts will become a reality by a centralised control system through this service with collaboration among logistics companies and TOYO's plant owners around the world (Fig. 16).

## Improving plant operation with tkIS digital solutions

For thyssenkrupp Industrial Solutions (tkIS), digitalisation is not an end in itself, but a promising tool that can bring concrete benefits to customers:

- better safety;
- higher uptime;
- higher production;
- better efficiency;
- improved maintenance planning.

Solutions for collection, handling, storage and processing of the vast amount of data generated by a plant are there to be turned into tangible benefits for the plant operator. Depending on the type of plant or process, this can be by a digital twin of the plant or by statistical data evaluation, or by other digital solutions, like an operator training simulator.

The following case studies show how tkIS can improve plant operation by digital solutions<sup>7</sup>. Added value is created by combining state-of-the-art data analytics methods with thyssenkrupp's expert know-how as process licensor and EPC contractor.

Fig. 17 is a schematic showing the interaction between the customer and tkIS. As shown, recommendations are extracted from the process data in different ways. Several approaches exist to combine artificial and human intelligence (expert know-how). Selection is made depending on the process and the situation:

- Data-driven approach: Generic analytics and machine learning methods are employed, followed by expert interpretation of the results.
- Expert-driven approach: Known correlations, specifications and patterns are used as guiding principles for learning algorithms.

- Model-driven approach: Physics-based models and simulations are combined with real-time data analytics.

### Case study 1

#### Digital twin of plant for improved operation

An example of the model-driven approach is the creation of a digital twin of the plant. A process model is set up for the plant or a part of it and, while the plant is running, a simulation is constantly carried out using measurements for the plant as input. The simulation can be used for several purposes:

- It can detect inconsistencies in the online measurements, e.g. if a change in concentration and temperature across a reactor do not match.
- It can provide virtual sensors, i.e. give information where no physical sensors are installed.
- It can be used for the tuning of control loops.
- The simulation can be used to look ahead in time, e.g. predict the behaviour of the plant with increased fouling of heat exchangers, deactivated catalysts etc.
- The simulation can be subjected to an optimisation algorithm with best process efficiency, maximum production, or any other parameter as the target function. It can thus inform the operator where selected process parameters deviate from the optimum and it can suggest a better setpoint. Such an algorithm has been implemented by tkIS at a fractionating column<sup>8</sup>. Process parameters have been combined with product and utility prices so that the profitability of the current process can be determined and used as the optimisation target. Fig. 18 shows an example of the output to the operator

where the margin for potential process improvements is displayed.

The analysis can be carried out by tkIS if the process data is exported from the plant's control system to a safe tkIS server. The data can be made available online or in batches every day, every week or similar. The same principle also applies to the following case studies.

### Case study 2

#### Statistical data analysis – trip prevention

Ammonia plant operating data from several hundred transmitters have been collected over several months, comprising both normal operation and time of unwanted loss of production.

The data is fed to a software package for statistical data analytics. It is treated in several steps: After pre-processing (cleaning by deletion of obviously erroneous measurements) average values, trends and standard deviations are determined. The data is then tested for correlations and anomalies and outliers are detected. An interpretation of these data by a process expert is made in order to train the software to distinguish between "good" and "bad" operating conditions.

In one case, it has been demonstrated that about ten days prior to a trip, the plant had been operating permanently under "bad" conditions, even though at first sight nothing abnormal could be seen in the individual data points<sup>9,10</sup>.

That means, if such a system has been working in "live" mode with plant data it would have issued a warning that there was a mismatch in the data. This alone would not have prevented a failure or a trip but it could have been used to alert a process expert to have a closer look at a particular set of data.

Fig. 18: Screen view of the calculated profitability of the actual plant (black) and the optimised digital twin (green)



Source: tkIS

Fig. 19: Artificial neural network (ANN): Left: Input parameters; right: output parameters

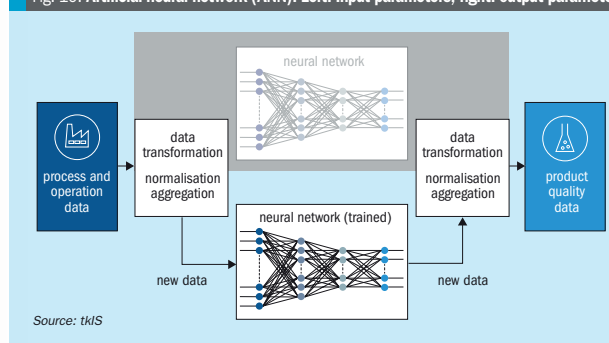

It should be noted again that the evaluation is purely by statistical methods and (different to case study 1) with no process model or process simulation. Data which are not part of a usual process simulation like oil temperature, machine vibrations etc. are also part of the evaluation. The advantage is that this strategy also works with processes or parts thereof where no rigorous process simulation is available. The process know-how of tkIS is used in order to train the system and to find causes when an anomaly is detected.

### Case study 3

#### Neural network for improvement of product quality

While the challenge in an ammonia plant may be to achieve most efficient production, in a CAN or urea granulation plant the

challenge is to ensure a uniform product quality. Product quality parameters (e.g. composition, granulometry, hardness) cannot be measured online, they are tested in the laboratory, which means there is a time delay before they are available to the operator. As a consequence, off-spec product can accumulate before it is discovered.

Therefore, to be able to predict product quality based on process parameters which are measured online would be a great improvement. Unfortunately, the interdependence between process parameters and product quality is highly complex and there is no process model available which can be turned into equations for this purpose. However, an artificial neural network (ANN) can bridge this gap.

Its working principle is illustrated in Fig. 19. Input and output parameters

each form a layer of variables which are linked with each other via intermediate variables in hidden layers. Each variable is influenced by each of the variables in the previous layer by a function (propagation function), containing fittable parameters.

ANN is applied in two phases, the training phase and the working phase.

First, in the training phase, known input and output data (historical data for online measured operating parameters and for product quality) are used to fit the internal parameters of the ANN in such a way that it accurately predicts these known output parameters.

Second, in the working phase, the previously determined internal parameters are fixed, and using the actual operating parameters as input, the product quality is predicted online.

thyssenkrupp Industrial Solutions is in co-operation with producers to implement such models. In one application, 93% accuracy has been reached (actual product quality within a confidence interval of prediction). The advantages are clear<sup>9</sup>:

- no time delay to take corrective action if the product quality starts to deviate;
- less workload for the laboratory (if the ANN reliably predicts product quality is well above requirements);
- Better average product quality.

### Case study 4

#### KPI generation and domain knowledge interpretation

Close monitoring of the plant condition is essential to achieve optimal performance. thyssenkrupp Industrial Solutions provides condition monitoring of plants including reporting and consulting services. The objective is to optimise the key performance indicators (KPIs) of the plant.

Analysis of the operating data is the basis for such services. The principle is shown in Fig. 20. Operating data is collected and stored at site by the thyssenkrupp data logger, which is connected to the plant DCS. Data exchange is achieved using standard interfaces, e.g. OPC UA, or specialised interfaces depending on the requirement at hand. The stored data can also be visualised in connection with a mobile device. The thyssenkrupp data logger is also a platform for future special purpose. The concept of reports relies on the secure transmission of the plant data to the thyssenkrupp Internet of Things (IoT) cloud, where the aggregation and interpretation of the results is performed.

Fig. 17: Information flow between fertilizer producer and tkIS for process modelling

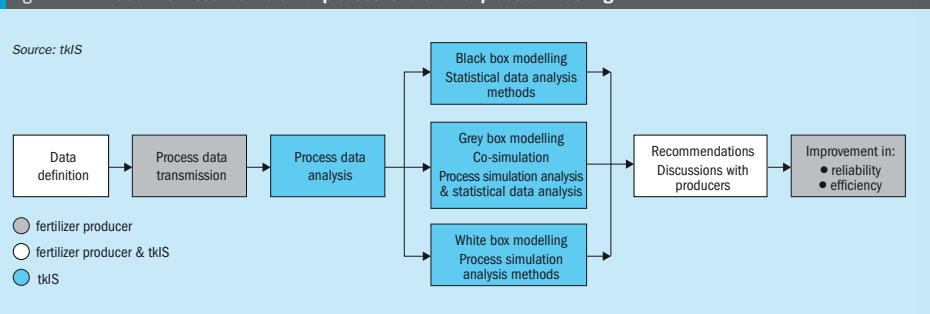

What's in issue 368

COVER FEATURE 1

The future of DME

COVER FEATURE 2

Nitric acid carbon credits

COVER FEATURE 3

Revamping ammonia plants

COVER FEATURE 4

Plant digital solutions

NITROGEN+SYNGAS  
ISSUE 368  
NOVEMBER-DECEMBER 2020

BCInsight

Southbank House, Black Prince Road  
London SE1 7SJ, England

Tel: +44 (0)20 7793 2567

Fax: +44 (0)20 7793 2577

Web: www.bcinsight.com  
www.bcinsightsearch.com

Fig. 20: Infrastructure for data analysis and reporting/consulting services

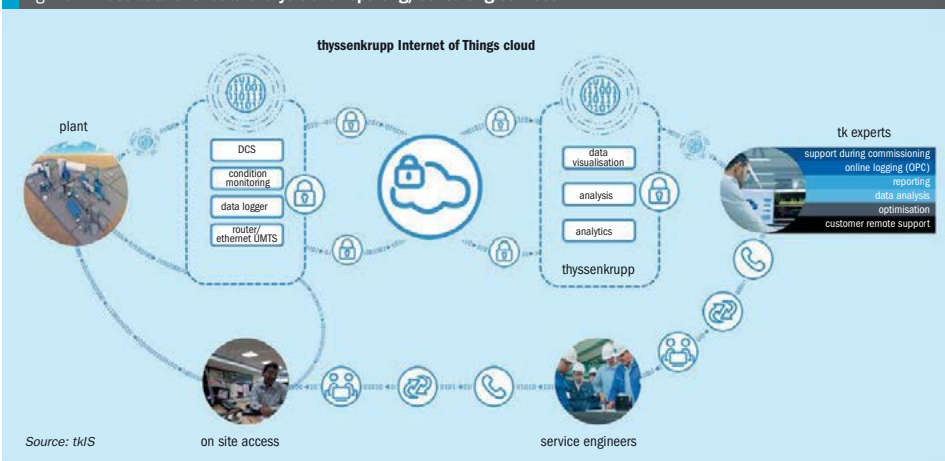

Source: tkIS

Fig. 21: Example pages of a report for an ammonia plant

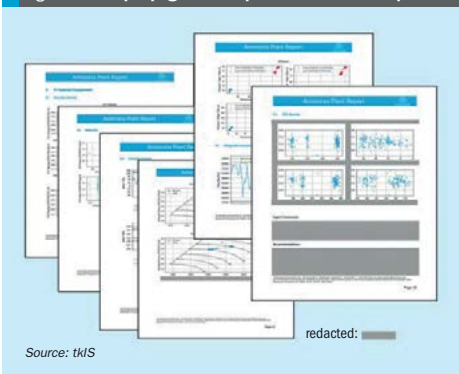

Source: tkIS

Analysis tools running in the cloud check the operating data and generate early warnings in case of unusual operating conditions. These analysis tools are developed in close cooperation between tkIS' data scientists and technology experts and are fine-tuned by the input and according to the needs of the client. Typical KPIs investigated comprise high level KPIs like plant efficiency and feedstock/utility consumption and more detailed KPIs like turbine efficiencies, catalyst performance, heat exchanger fouling rates etc. Comparisons of plant performance in the current year with the performance achieved in the previous year around the same time

are also often requested by tkIS clients, enabling the client to spot subtle problems or benchmark successful revamps in a thorough and methodical way.

The data is analysed by tkIS technology specialists and data scientists on a regular basis and reports including visualisation of operating data, description of the plant status, documentation of findings and recommendations for operation and maintenance are prepared.

Fig. 21 shows some example pages from a typical report. As one can see, the visualisations are not only time series related but are selected with care from the tool box of the data scientists to maximise

Fig. 22: Schematic picture of the real plant (left side) and simulated plant (right side) including the plant, the safety system (PLC) and the control system (DCS)

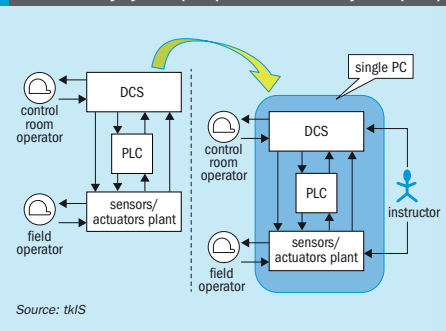

Source: tkIS

the information transported. The transport of the data to the cloud allows tkIS to use more sophisticated calculation mechanisms, including thermo-physical properties and in-house calculation models. In addition to these automatically generated figures technology experts analyse the data and can include comments and recommendations to optimise the performance of the plant.

Last but not least if the client agrees, tkIS can use the data in an anonymised form to compare the performance of the plant to similar plants and benchmark the plant's performance against the best operating installations.

Fig. 23: User interface of training simulator for ammonia synthesis loop for DCS view (left side) and field view (right side)

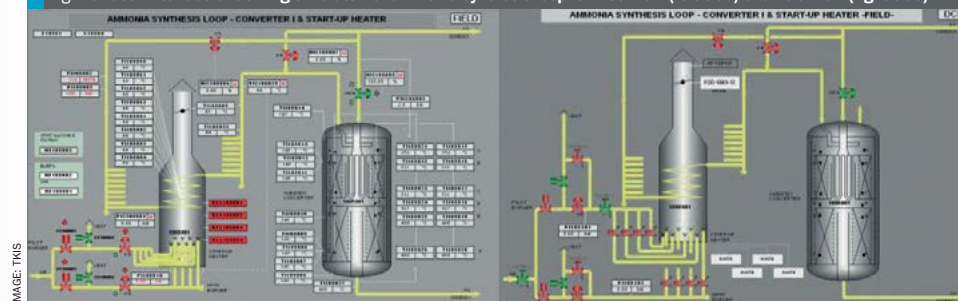

IMAGE: tkIS

### Case study 5

#### Operator training simulator (OTS)

thyssenkrupp Industrial Solutions trains operators and employees (trainees) in training sessions using a digital copy of a standard tkIS fertilizer plant. Using the plant simulator, the trainee can go through the start-up procedure from a cold state step by step. Secondly, he or she can learn how to react in critical situations, such as a failure of a critical equipment which can lead to a trip. In the best case, after training the operator can prevent a trip and feels more confident in difficult scenarios. A properly trained operator is key for the safe and reliable operation of the plant. Training performed with an OTS are analogues to flight simulators where pilots purposely train for hazardous and failure scenarios without a real risk, in order to be able to handle these scenarios optimally.

A very simplified scheme of the simulator is shown in Fig. 22. On the left hand side, the real plant including the real safety system (PLC) and the control system (DCS) is shown. Two specialised computers are normally installed to handle the data. Operators can influence the plant either through the hand valve in the field (visualised by the field operator) or by varying parameters in the DCS (shown in Fig. 22 as the control room operator). All these possible interactions are implemented in the training simulator shown on the right hand side in Fig. 22. The ammonia plant can be simulated and installed on one single computer. To train for different scenarios, a so called "instructor" can influence the parameters of the plant. For example, the instructor can force a pressure drop of the natural gas at battery limit conditions, start a failure of a part of the plant or change the surrounding conditions.

Anyone who wants to learn about the plant behaviour can sign in as a trainee. A trainee can interact with the simulated plant, similar to the real plant. The screen view mimics the DCS system. The position of every valve can be changed and, if it is a control valve, the set point can be changed. Every change leads to a different time-dependent behaviour of the plant including changes in the operating parameters such as temperature or pressure.

The trainee can switch between two different views. The DCS view closely mimics the design of a real DCS. Here, the trainee works like a control room operator as described above and can view the alarm list or the trip schedule. The second possible view is the so called "field view". By switching to field view, the trainee can see all field instruments and operate all hand valves, too. These two different visualisations are shown in Fig. 23 showing the ammonia synthesis loop as an example.

A more advanced solution for field operator training might also be based on a virtual 3D environment, which tkIS is able to develop in cooperation with a company specialised in this regard on request of the client. This 3D environment is based on the 3D models already created during the plant construction phase and offers the ability for a deeper level of immersion. The training can be performed individually or several trainees can connect with their electronic device to one plant simulation. Tasks can be split among the group of trainees and the communication between the field operator and the operator in the control room can also be practised. The training sessions have different levels of complexity, starting with an easy level for beginners. One additional option of the OTS is to practice the tuning of the controllers.

## CONTENTS

What's in issue 368

## COVER FEATURE 1

The future of DME

## COVER FEATURE 2

Nitric acid carbon credits

## COVER FEATURE 3

Revamping ammonia plants

## COVER FEATURE 4

Plant digital solutions

The goal of the operator training system is to train the operator to be more confident in challenging scenarios, equipping the operator with the knowledge and training to prevent trips, optimise the plant considering the most important impacts and handle the tuning of controllers.

tkIS has prepared standard training procedures for the different levels of complexity, but is also able to adapt the training program based on the client's needs.

The simulator can provide benefits to fertilizer plants such as ammonia, nitrate or nitric acid plants.

### References

- Rams L. (Stamicarbon): "safely push your urea plant to maximal production", prepared for *Nitrogen+Syngas* (Oct 2020).
- Rams L. (Stamicarbon): "Boost performance with real-time insights", *Nitrogen+Syngas* No. 365, pp. 39-41 (May-Jun 2020).
- Gebhard E. (OnPoint Digital Solutions): "Smart Combustion™: "Digital solutions to optimise primary reformer heater operations", prepared for *Nitrogen+Syngas*, (Oct 2020).
- "Making the most of plant data", *Nitrogen+Syngas* No. 354, pp. 32-40 (Jul-Aug 2018).
- "Starting the digitalisation journey", *Nitrogen+Syngas* No. 360, pp. 46-53 (Jul-Aug 2019).
- "Making construction sites safer", *Nitrogen+Syngas* No. 360, pp. 28-37 (Jul-Aug 2020).
- Franz J., Poschlad K. and Wagner D. (tkIS): "Digital Innovations", prepared for *Nitrogen+Syngas*, (Oct 2020).
- El Hawary T.: "Plant data assessment by statistical and process analytics methods", AFA Operation & Maintenance in Fertilizer Industry Workshop, Muscat, Oman (2018).
- Franz J.: "Optimisation of fertilizer plants by digitalisation and automation", GPCA Fertilizer Convention, Muscat, Oman (2019).

# Advertisers' index

**Editor:** RICHARD HANDS  
richard.hands@bcinsight.com

**Technical Editor:** LISA CONNOCK  
lisa.connock@bcinsight.com

**Contributors:**  
ALISTAIR WALLACE  
alistair.wallace@argusmedia.com

**Publishing Director:** TINA FIRMAN  
tina.firman@bcinsight.com

**Subscription rates:**  
GBP 425; USD 850; EUR 655

**Subscription claims:**  
Claims for non receipt of issues must be made within 3 months of the issue publication date.

**Sales/Marketing/Subscriptions:**  
MARLENE VAZ  
Tel: +44 (0)20 7793 2569  
Fax: +44 (0)20 7793 2577  
marlene.vaz@bcinsight.com  
Cheques payable to BCInsight Ltd

**Advertising enquiries:**  
TINA FIRMAN  
tina.firman@bcinsight.com  
Tel: +44 (0)20 7793 2567

**Agents:**  
**Japan:** (also subscription enquiries)  
KOICHI OGAWA  
O.T.O. Research Corporation  
Takeuchi Building  
1-34-12 Takadanobaba  
Shinjuku-Ku, Tokyo 169, Japan  
Tel: +81 3 3208 7821  
Fax: +81 3 3200 2889

**Previous articles** from *Nitrogen+Syngas* and *Nitrogen & Methanol* from 1996 to the present are available digitally in PDF format. To make a purchase, or for a list of available articles, please see: [www.bcinsight.com](http://www.bcinsight.com)

**Copyright:** Issued six times per year, or bi-monthly. All rights reserved. No part of this publication may be reproduced, stored in a retrieval system or transmitted in any form or by any means – electronic, mechanical, photocopying, recording or otherwise – without the prior written permission of the Copyright owner.

ISSN: 1750-6891

**Design and production:**  
JOHN CREEK, DANI HART



**Printed in England by:**  
Buxton Press Ltd  
Palace Road, Buxton, Derbyshire,  
SK17 6AE

© 2020 – BCInsight Ltd

**BCInsight**

**Published by: BCInsight Ltd**  
China Works, Unit 102,  
100 Black Prince Road,  
London SE1 7SJ, UK  
Tel: +44 (0)20 7793 2567  
Fax: +44 (0)20 7793 2577  
Web: [www.bcinsight.com](http://www.bcinsight.com)  
[www.bcinsightsearch.com](http://www.bcinsightsearch.com)

Advertiser	Page	Website
Argus Media Co	29	argusmedia.com
ARVOS GmbH SCHMIDTSCH SCHACK	49	arvos-group.com
Blasch Precision Ceramics	23	blaschceramics.com
Borsig GmbH	21	borsig.de
Casale	11	casale.ch
Eurotecnica Contractors and Engineers	OBC	eurotecnica.it
Eurotecnica Contractors and Engineers	5	eurotecnica.it
Johnson Matthey	IFC	matthey.com
Nitrogen + Syngas 2021 Virtual Conference	IBC	crugroup.com/events
Sabin Metal Corporation	17	sabinmetal.com
Steinmüller Engineering	9	steinmueller.com/en
Tecnimont Group	53	mairetecnimont.com/en
UNICAT Catalysts Technologies Inc	25	unicatcatalyst.com/
Ventilatorenfabrik Oelde GmbH	13	venti-oelde.com

## Next issue: January/February 2021

### Nitrogen + Syngas 2021 Virtual Conference issue

- Towards a sustainable nitrogen fertilizer industry  
Part 1 – nitrogen production
- Gas pricing and market reform
- Digitisation in the fertilizer industry – scope and potential
- Project progress during Covid-19
- NOx emissions reduction in steam methane reformers

**For further information and to book advertisement space contact:**  
**Tina Firman, Publishing Director:** [tina.firman@bcinsight.com](mailto:tina.firman@bcinsight.com)  
**Tel: +44 (0)20 7793 2567 Fax: +44 (0)20 7793 2577**

34th

# CRU Nitrogen + Syngas 2021 Virtual Conference

1-3 March 2021

Maximising efficiency through innovation and knowledge sharing

“ Nitrogen + Syngas is the conference for future business. ”  
Omar Takrouni, President, Jubail Fertilizer Company (Al Bayroni)

## About this event

For 34 years, CRU's Nitrogen + Syngas conference has provided an annual platform for the global industry to meet, network, and learn. Every year, hundreds of producers, licensors, and materials and equipment providers attend to ensure they have knowledge, understanding and professional connections required to improve their production, maximise profitability, and maintain safe, reliable, and environmentally responsible operations.

In 2021, as a virtual event, the conference offers real insight, real networking, and real business opportunities. More than just a series of webinars, the virtual event incorporates a three-day, multi-streamed agenda of technical presentations; a virtual exhibition for meeting with technical experts and sourcing solutions; and integrated networking including live video, audio and text chat, interactive discussion groups, and meetings scheduling.

Whether you are investing in a new plant, revamping an existing plant, or maintaining your plant to achieve optimal production, safety and environmental performance, Nitrogen + Syngas is a 'must-attend' event.

## Event Highlights

50+  
technical papers and presentations

Operators go FREE - apply today

12+  
hours of technical training

60+  
world-class exhibitors

740+  
professional representing

2020 attendance

330+  
companies and

46+  
countries

Official Publications



Supporters

For more information and to book your place, visit [www.nitrogensyngas.com](http://www.nitrogensyngas.com)

CONTENTS

What's in issue 368

COVER FEATURE 1

The future of DME

COVER FEATURE 2

Nitric acid carbon credits

COVER FEATURE 3

Revamping ammonia plants

COVER FEATURE 4

Plant digital solutions

NITROGEN+SYNGAS  
**ISSUE 368**  
NOVEMBER-DECEMBER 2020

**BCInsight**

Southbank House, Black Prince Road  
London SE1 7SJ, England  
Tel: +44 (0)20 7793 2567  
Fax: +44 (0)20 7793 2577  
Web: [www.bcinsight.com](http://www.bcinsight.com)  
[www.bcinsightsearch.com](http://www.bcinsightsearch.com)



1  
2  
3  
4  
5  
6  
7  
8  
9  
10  
11  
12  
13  
14  
15  
16  
17  
18  
19  
20  
21  
22  
23  
24  
25  
26  
27  
28  
29  
30  
31  
32  
33



# Euromel® Melamine The industry benchmark

23 plants worldwide. 5 million tonnes produced. No pollution. Euromel® is the world's leading melamine technology. Over the last 40 years, Eurotecnica has transformed the melamine market into a global operation by creating a melamine process that turns its Urea feedstock into a product that is profitable and in high demand.

Today, 23 melamine plants around the world have been licensed and implemented on the basis of Euromel®, with a combined annual capacity of nearly 800,000 tons. Euromel® has also become the process with the lowest OPEX in the industry with zero-pollution, low energy consumption and no chemicals added for purification. Therefore investing in Euromel® means gaining access to a sustainable technology with a global network of producers.

Contact us at [www.euromel.com](http://www.euromel.com) to find out more.

**EUROMEL®**

**ET EUROTECNICA**  
MAKING SUSTAINABILITY PROFITABLE

## Don't forget the next issue of **Nitrogen+Syngas** January/February 2021



CONTENTS

What's in issue 368

COVER FEATURE 1

The future of DME

COVER FEATURE 2

Nitric acid carbon credits

COVER FEATURE 3

Revamping ammonia plants

COVER FEATURE 4

Plant digital solutions

**NITROGEN+SYNGAS**  
**ISSUE 368**  
NOVEMBER-DECEMBER 2020

# BCInsight

Southbank House, Black Prince Road  
London SE1 7SJ, England  
Tel: +44 (0)20 7793 2567  
Fax: +44 (0)20 7793 2577  
Web: [www.bcinsight.com](http://www.bcinsight.com)  
[www.bcinsightsearch.com](http://www.bcinsightsearch.com)